

Rearing of the seahorse
Hippocampus guttulatus:
Key factors involved in
growth and survival



**Universitat de les
Illes Balears**

ANDREU BLANCO CARTAGENA
Marine Ecology doctorate programme

PhD Thesis
2014

Dr. Miquel Planas Oliver, scientific researcher from the department of Marine Ecology and Biodiversity at the Institute of Marine Research of the National Council of Scientific Research, certifies that:

The present thesis, entitled “**Rearing of the seahorse *Hippocampus guttulatus*: Key factors involved in growth and survival**” is a novel work and has been fully written by Andreu Blanco Cartagena and carried out under the advisement of Dr. Miquel Planas Oliver. The University tutor, Dr. Gabriel Moyà Niell allows its defence to the Department of Biology, responsible of the doctorate programme of Marine Ecology.

University tutor,

Doctorand,

Thesis director,

Dr. Gabriel Moyà Niell
Professor and researcher
University of the Balearic
Islands (UIB)

Andreu Blanco Cartagena

Dr. Miquel Planas Oliver
Researcher
Marine Research Institute
(IIM-CSIC)



Rearing of the seahorse *Hippocampus guttulatus*: Key factors involved in growth and survival

PhD Thesis presented by:
ANDREU BLANCO CARTAGENA

to obtain the degree in:
Marine Ecology

Palma de Mallorca, 2014



Universitat de les
Illes Balears



“Y no pienses, recuerda”
Guillermo Cartagena Tello, 2003

“Hombre libre, ¡siempre adorarás la mar!”
Charles Baudelaire

A mi familia, os quiero.

Index

Acknowledgements	XI
Abstract / Resum	XV
1. Introduction	1
2. Objectives	31
3. General Material and Methods	35
3.1. Seahorse Collection	37
3.2. Broodstock captive conditions	38
3.3. Rearing of juveniles	41
3.4. Production of live food	43
3.4.1. Microalgae	43
3.4.2. Rotifer, <i>Brachionus plicatillis</i>	44
3.4.3. Brine shrimp, <i>Artemia</i> sp.	45
3.4.4. Calanoid copepod, <i>Acartia tonsa</i>	45
3.5. Juvenile sampling	46
3.6. Proximal biochemical composition	47
3.6.1. Total Lipid content	47
3.6.2. Total Protein content	48
3.6.3. Soluble Carbohydrate content	48
3.6.4. Ash content	48
CHAPTER 1:	
Implications of physical key factors in the early rearing of the long-snouted seahorse <i>Hippocampus guttulatus</i>	49
1.1. Introduction	52
1.2. Materials and methods	54
1.2.1. Broodstock	54
1.2.2. Rearing system	55
1.2.3. Experiment 1: Aquaria Design and Photoperiod	56
1.2.4. Experiment 2: Aeration Intensity	58
1.2.5. Sampling and data analysis	59

1.3. Results	60
1.3.1. Experiment 1: Aquaria Design and Photoperiod	60
1.3.2. Experiment 2: Aeration Intensity	63
1.4. Discussion	63
1.5. Conclusions	69
CHAPTER 2:	
Temperature-induced changes of growth and survival in the early development of the seahorse <i>Hippocampus guttulatus</i>	71
2.1. Introduction	74
2.2. Materials and methods	75
2.2.1. Broodstock	75
2.2.2. Rearing system	76
2.2.3. Experiment 1: Feeding conditions	77
2.2.4. Experiment 2: Starvation conditions	77
2.2.5. Sampling and data analysis	78
2.3. Results	80
2.3.1. Feeding juveniles	80
2.3.2. Starving juveniles	84
2.4. Discussion	85
CHAPTER 3:	
Mouth growth and prey selection in juveniles of the European long-snouted seahorse <i>Hippocampus guttulatus</i>	91
3.1. Introduction	94
3.2. Materials and methods	95
3.2.1. Seahorse culture	95
3.2.2. Prey culture	96
3.2.3. Experimental procedures	96
3.2.4. Sampling and data analysis	98
3.3. Results	100
3.4. Discussion	105
3.5. Conclusions	111

CHAPTER 4:

Improvements in the rearing of the seahorse <i>Hippocampus guttulatus</i> Cuvier 1829 by the use of copepods	113
4.1. Introduction	116
4.2. Materials and methods	118
4.2.1. Seahorse culture	118
4.2.2. Rearing system	118
4.2.3. Prey culture	119
4.2.4. Experimental design	119
4.2.5. Seahorse sampling	120
4.2.6. Proximal biochemical composition	121
4.2.7. Data analysis	121
4.3. Results	122
4.4. Discussion	123
4.5. Conclusions	130

CHAPTER 5:

Ontogeny of digestive enzyme activities in juvenile long snouted seahorses <i>Hippocampus guttulatus</i> fed on different live diets	131
5.1. Introduction	134
5.2. Materials and methods	135
5.2.1. Broodstock	135
5.2.2. Rearing system	136
5.2.3. Feeding conditions	137
5.2.4. Seahorse sampling	138
5.2.5. Enzyme activities determination	139
5.2.6. Data analysis	141
5.3. Results	141
5.4. Discussion	146
5.5. Conclusions	151

CHAPTER 6:

Closing the life cycle of the European long-snouted seahorse <i>Hippocampus guttulatus</i> Cuvier 1829	153
6.1. Introduction	156
6.2. Materials and methods	157
6.2.1. Broodstock	157
6.2.2. Rearing system	158
6.2.3. Feeding conditions	158
6.2.4. Prey culture	159
6.2.5. Experimental procedure	160
6.2.6. Data analysis	161
6.3. Results	161
6.4. Discussion	165
6.5. Conclusions	168
4. Summary	169
5. Conclusions	177
6. References	183
7. Annexes	219

ACKNOWLEDGMENTS

Esta es mi aventura: la historia de un chaval con una mochila en una ciudad nueva. Pero esta aventura no empieza en esa nueva ciudad, sino en Mallorca (“Sa roqueta”), ese pedacito de tierra en medio del mar que me vio nacer y crecer. Rodeado por mar, mi pasión por él y sus habitantes fue *in crescendo* desde pequeño. Con el inestimable apoyo de mi familia hice y deshice para empezar carrera en la investigación marina, la cual comencé en 2006 en el laboratorio de la Dra. Salud Deudero, a quien debo mis inicios, muchas gracias. De ahí, mi aventura se materializó con el beneplácito del Dr. Miquel Planas quien confió en mí y me brindó la oportunidad de salir de mi isla y conocer mundo, quien me apoyó durante momentos de flaqueza y me permitió poder realizar un sueño; sin tu respaldo jamás hubiera podido hacer todo lo que he hecho. Por el lado burocrático-administrativo quisiera agradecer al Dr. Biel Moyà, gracies per fer-me de pont entre institucions. Quisiera agradecer también al Dr. Pepe Pintado, cuya aportación profesional y personal ha permitido mejorar mi orden ambiental y, consecuentemente, mental. Tengo que agradecer a Sonia Valladares su ayuda en la búsqueda de caballitos en los mares de Galicia. Este mar gallego me ha enseñado tanta diversidad que no ha dejado de asombrarme desde la primera inmersión. A Patricia Ruiz me gustaría agradecerle su constante sonrisa y su capacidad logística.

Especialmente quisiera agradecer al resto del equipo: A Tomás Hermelo, galego onde os haxa; moitas grazas por falar-me galego dende o inicio e ensinarme os costumes da terra, dende as agrolimpiadas e o licor café ata o carnaval do Hio e os petroglifos, entre outros moitos, e grazas por presentarme a túa xente do Morrazo. A la Dra. Patricia Quintas, Patri, quien me facilitó todo desde el primer día, por tu amistad y ayuda en todo, mil gracias. A Alex Chamorro, a quien prácticamente debo esta tesis. Me enseñaste de todo, desde el cultivo en acuarios hasta cómo hacer una mesa, siempre a tope y dispuesto a echarme una mano con lo que fuera, muchísimas gracias. A Claudia Ofelio, quien además de compañera de laboratorio ha sido una gran amiga y un buen apoyo en momentos duros. No sólo te has ocupado de los cultivos durante mis últimos fines de semana, sino que, además, me has sacado muchas sonrisas. A todos estos compañeros os lo agradezco de corazón, cuando las cosas se me pusieron realmente difíciles siempre me lo facilitasteis todo.

Mis primeros pinitos en la ciencia los compartí con el Dr. Toni Box, la Dra. Silvia Tejada, el Dr. Antoni Sureda y el Dr. Guillem Mateu, a quienes agradezco mis inicios, junto a otros compañeros. Además, no quisiera olvidarme de quienes, de un modo u otro

otro, han puesto su granito de arena en la realización de esta tesis ayudándome en cultivos, experimentos y rutinas: Juanpi, Fernando, Mariana, Jarintzin, Vanessa, Tania, David, Rita, Irene, Lucía, Alba, Diana, Manuel, Rachel, Jose, Beto, Alex y algún otro que haya volado de mi cabeza cual pájaro al viento. A todos aquellos que habéis hecho que el IIM no fuera sólo un lugar de trabajo, haciéndolo lugar de risas y divagación intelectual: Fiona, Isabelinha, Silvinha, Marcelo, Alba, Maruxa, Lorena, Marcos, Jose, Miguel, Raquel, personal de conserjería y otros tantos que han amenizando mi paso por el centro.

Los inicios en una nueva ciudad pueden hacerse difíciles, pero al final, cuando haces lo que te apasiona y lo haces rodeado de gente buena, todo es mucho más llevadero. A mi arribada me reencontré con Laura y Judit, que hicieron que Galicia tuviera alguna razón para convertirse en mi destino y en mi hogar, gracias desde el minuto 0. Al inicio de mi sendero no pude cruzarme con mejor compañía que la de JuanPi, con quien recorrí tierra firme en busca de conciertos, ciudades y demás lugares, gracias pana! Cris e Isa, mis coleguiñas, salieron a mi paso y desde entonces han compartido esta experiencia conmigo; llevándome a crear, junto a Jorge, Noha y Sergio, el grupo de apoyo a doctorandos marinos mediante el uso terapéutico del humor gráfico, y así conseguir arrancarme sonrisas durante las largas horas de trabajo. Bego, has sido un apoyo indispensable en este paseo gallego, un bastón que me ha permitido avanzar cuando flaqueaba, gracias. A Peque, Iago y Marisa, por disfrutar conmigo de los placeres de vuestra tierra y pasar mi única noche vieja gallega a mi lado. Jari y nuestra niña, Vane, con quienes pasé a un estado de euforia neurótica de risoterapia asistida tanto dentro como fuera de nuestro hogar; buenos momentos de un verano memorable. La cronología de los acontecimientos me lleva a recordar con cariño y apego a mucha gente que ha compartido conmigo techo, lar y microaventuras paralelas: Juanpi, Victorine, Justyna, Edyta, Dani, Arturo, Lois, Manu, Clau, Paolo y Alex. Gracias por hacer de mi casa vuestra casa (y viceversa), por compartir esos momentos hogareños tan necesarios en el día a día.

Los derroteros de este viaje me llevaron a conocer mundo. Prima ad Ancona, in Italia, che esperienza! Questa opportunità la devo al Dr. Ike Olivotto a cui voglio ringraziare per la sua pazienza e la sua amicizia, e alla Dra. Isabella Buttino che mi ha fatto imparare l'allevamento dei copepodì. Dal primo giorno fino all'ultimo un ringraziamento alle famiglie italiane che mi hanno ospitato, Montali, Capitanelli, Morroni, Casadio, Ceglia e Olivotto. A tutte le persone che hanno condiviso questo momento con me e mi hanno fatto conoscere la vera Italia: Sandro, Sere, Marco, Lorenzo, Luca, Gloria, Ari, Mattia, Francesco, Luca, Lorenzo, Margherita, Maria Lisa, Anna, Lisa, Chiara, Silvio, Vale, Laura e tutti quelli che

hanno fatto che questa esperienza in Italia fosse più facile, siete tutti grandissimi! Sorprendido por mi propio destino me vi embarcando hacia el “nuevo continente”, América me esperaba. Texas, where I had the opportunity to live thanks to Dr. Joan Holt, who accepted me in her lab. To Dr. Lee Fuiman, thank you for allowing me to materialize such an amazing experience and for providing me with all the materials I needed to do my research in Port Aransas. In a heartbeat, “Port A” became my home and increased my happiness levels to the top. Everyone in that little town helped me in one way or another. I would like to especially thank: Bill (for being such a nice flat mate), Moises and Cata (for helping me on my English relief and for making everything easier), Chenan (for my first days in Port A, for correcting me and for your hospitality in my trip to Chicago), John (my surfing buddy, darts teammate, neighbor and amigo, you rock it!), Lisa (for such a wonderful thanksgiving lunch and host), Karen (I will always remember our trip; it was so great, just as I expected!), Ellen (volleyball master), Thom (yoga master), Lindsey, Matt, Nick, Daryl, Sheena, Kellie, Colt, Colleen, Claire, Nicole, The Gajeenaz and everyone that helped on tattooing Port A in my mind forever. But my experience in the US was only about to start. Florida was waiting for me and in less than two months I was taking off again to Vero Beach. Thank you Dr. Junda Lin for allowing me to spend 3 months working hand-in-hand with Nancy Pham to who I would like to specially acknowledge for being my colleague, my friend and for taking me to the land where dreams can come true. I would also like to thank Adeljean, for bearing my craziness and all your help. Mi último desvío me llevó a Almería, paréntesis de sol y desparpajo. Con la ayuda del Dr. Francisco J. Moyano, a quien agradezco esta posibilidad y su amabilidad dentro y fuera del laboratorio. Adela, a ti que me diste la oportunidad de disfrutar tu tierra, gracias.

Durante este camino he compartido sendero con varios buenos compañeros y amigos. Gente que sin ni siquiera imaginarlo se ha metido tan de lleno en mi vida que ahora son mi gente, son mi pilar y mi soporte y a quienes debo especial mención por su inmensa amabilidad, amor y compañía. A Álvaro, te debo mucho man! me mantuviste en la cresta de las olas, a tope con pack multiaventura, y me metiste de pleno en tu pulpifamily, Alex y Nico, con quienes me has demostrado que ser padre puede ser muy bonito. A Milo y Paula, dos gallegos mallorquines de adopción, no pudo ser más que vuestra bondad (y los retrasos aéreos) la que nos uniese. Miguel, por tu humor satírico-burlesco con toques de ironía y aprecio, por esas lubinacas y por esas cenas; gracias Boff. Bertño, tú y tus consejos de escalada me habéis despertado una gran afición, lo bueno siempre viene en frascos pequeños.

Victor, Grinch o capitán, sinonimia conceptual que me remite a un referente común de caradura y buen humor, mezcla explosiva en el vaivén del mar. Y a toda la troupe que ha hecho de éste sea un gran grupo, unos amigos que, sin duda, siempre llevaré en mi corazón: Patri, Zapa, Bieito, Félix, Maite, Towers y muchos otros, muchas gracias a todos. En esta aventura lo bueno vino al final y por eso, para el final dejo un agradecimiento especial para Maria, por ser así, por tu bondad, por tu paciencia y tu cariño para conmigo, por apoyarme y aguantarme, por cada uno de los momentos. Han sido unos meses duros, sí, pero valdrá la pena!

A la gente de mi tierra: han estat molts d'anys d'aguantar-me, heu fet que arribàs allà on he arribat, m'heu ajudat sabent-ho i sense saber-ho. Sou família i, per això vos vull agrair profundament haver pogut comptar sempre amb voltros, gràcies cosinetes: Maria Antònia, Aina B, Aina V, Dolors. I gràcies també a tota aquesta genteta de Mallorca que me fa enyorar-la tant: Rosa, Albert, Kat, Mika, Júlia, Marina, Imma, Carme, Jaume, Sergi, i molts altres. A los que me acompañasteis antes y después de emprender camino: Aida, Núria, Fran, Pablo, Tocho, Mario, Luis E., Leticia, Franziska, Diana, Cata, Cris, Oli, Aurora, Noe, Josep, Ana, Maite, Patri, Luis y demás compañeros y amigos que me habéis hecho fuerte. A M. Luz, por estar siempre ahí, dispuesta a dejar lo que estuvieras haciendo por verme, gracias. A Beni (con todo mi amor, ya sabes!), Chumi (ésta sólo puedes ser tú), Mónica i Juny (que grans sou!), Pitu, Lucia, Amanda, Pelu, Silvia, Bea y alguno que otro más, seguro. Chris y Álex, ¿qué decir de vosotros? ¡Gracias chavales! Muchísimas gracias, por vuestro apoyo y comprensión, por esas noches de despiporre y esas conversaciones a tres, por ayudarme en la tesis y en mi vida, por todo, sois lo más.

Por último, a mi familia. Podría alargar esto hasta el infinito agradeciéndoos todo lo que habéis hecho, podría no acabar nunca de halagaros, podría haberos reservado los agradecimientos sólo para vosotros; lo que no podría es haberlo conseguido sin vosotros, sin vuestro apoyo incondicional y vuestra fuerza, a todos gracias. Iván, en este tiempo has pasado a ser legalmente uno más de la familia, aunque en nuestros corazones siempre lo has sido, por eso y por estar ahí y ser así, te dedico estas palabras, muchas gracias. Ester, no puedo sentir más orgullo de ser tu hermano del que siento, tú eres mi mentora y mi guía, siempre sabes qué decirme y cómo apoyarme, siempre. Sin ti y tu ayuda esto hubiese sido muy, muy difícil, así que miles de gracias! Con la mano en el corazón y mi mente lúcida, el mejor de mis pensamientos siempre va para mis padres, me habéis educado para luchar por mis propósitos y aquí estoy, consiguiéndolos, poco a poco. Esta tesis es para vosotros.

Gràcies, Gracias, Graciñas, Thank you, Grazie!

ABSTRACT / RESUM

Abstract

Seahorse wild populations are worldwide threatened by habitat loss, incidental by-catch and direct fishing pressure either for Traditional Chinese Medicine, aquarium trade or curios. Resilience variability of seahorses to population declines resulted in the inclusion of all seahorse species in the Red List of Endangered Species of the IUCN in 1996. Furthermore, all species were also included in 2002 in Appendix II of The Convention on International Trade in Endangered Species of Wild Fauna and Flora (CITES). Population declines require the application of conservation management measures such as captive-breeding for recovery of wild populations, a potential solution to guarantee wild population welfare. Successful seahorse aquaculture operations should develop low-technology protocols for seahorse rearing while providing a commercially viable trade ensuring conservation goals and offering alternative livelihood to wild-seahorse fishers.

The present Thesis is focused on the European long-snouted seahorse *Hippocampus guttulatus*, whose wild populations in the Galician coast are genetically under a long-term demographical reduction. The knowledge on husbandry and rearing of *H. guttulatus* in captivity were firstly initiated by Proyecto Hippocampus establishing a breeding protocol for adult seahorses and the base of knowledge for the rearing of juveniles

Breeding improvements with the addition of live shrimp (*Palaemonetes varians*) and mysidaceans (*Leptomysis* sp. and *Siriella* sp.) as diet supplement, and the establishment of breeding techniques for the artificial manipulation of the captive conditions resulted in the enhancement of mating events and breeding all year around, the production of high quality newborn and a huge reduction (from > 95% to 6%) in the presence of abnormal or immature newborn in captive breeding. After the establishment of adequate breeding conditions, the following step in the production of seahorse juveniles was the development of a successful rearing technique, which was the main objective of the present Thesis.

The initial limited knowledge on the rearing of juveniles resulted in low survivals and massive mortality events that diffculted deciphering the essential changes needed to achieve a reliable rearing technique. In the present Thesis, significant improvements were achieved by enhancing the rearing technique thorough the study at different levels: including zootechnics

(aquaria design), physical factors (aeration intensity, photoperiod and temperature) and feeding (prey preference, prey type/size and digestion capabilities).

The first step in the early larval rearing of fish is the establishment of an adequate rearing system in which the aquaria design results essential for seahorses. The design of satisfactory aquaria, ensuring an even distribution of prey and juvenile in the water column, and the assessment of aeration/water turbulence levels were found to be of great importance to avoid both the access of juveniles to water surface and the presence of stagnant volumes in the aquaria. Under optimal conditions, the appearance of water surface overcrowding, swim bladder dysfunctions and accidental ingestion of air bubbles must be reduced as much as possible to reduce undesired mortalities. Accordingly, the studies performed in this Thesis in which three different aquaria designs (rectangular, spherical and pseudoKreisel) and two different aeration intensities (weak and strong) were assayed. Significant improvements in rearing performances were reached when pseudoKreisel aquaria and strong aeration levels were used.

Average survivals in 30 days after release (DAR) juveniles fed on *Artemia* and copepods increased from 16-22% in rectangular and spherical aquaria to 69% in pseudoKreisel aquaria. Additionally, juveniles fed on *Artemia* showed a 3-folds increase in survival under strong aeration levels with respect to those under weak aeration levels (41 and 13%, respectively). However, no significant differences were found for aeration levels when seahorse juveniles were fed on diets supplemented with copepods.

Despite water circulation and turbulence in the aquaria, the positive phototaxis of juvenile seahorses could result in swimming to water surface. The lateral incidence of light of and the darkening of the upper part of the aquarium walls reduced brightness in water surface and walls and resulted essential if compared to previous results.

As seahorses are visual predators, it was hypothesised that an extended photoperiod (24h continuous light) together with the continuous availability of prey would increase growth and survival rates. However, the application of an extended light regime did not affect the rearing performance of seahorses when compared to a day-night photoperiod regime (16h Light :8h Dark).

Among physical factors potentially involved in the rearing success, temperature is one of the most important. Three temperature levels (15, 18 and 21°C) within the range of water surface temperatures registered annually in the Galician coast were studied. Growth and

survival resulted in suboptimal development of 30 DAR juveniles when reared at 15°C, a temperature which is not far from T_0 (Threshold temperature at which growth is arrested). Conversely, high performances were achieved at 18°C and 21°C both for growth (8% and 11%, respectively) and survival (86% and 81%, respectively). In that study, it was demonstrated for the first time the suitability of effective day degrees (D_{eff}°) as a temperature-independent scale to quantify growth in fed juveniles and growth models were obtained for temperatures ranging from 14 to 26°C.

Feeding and nutritional requirements have been considered a main bottleneck in the culture of seahorses. The early rearing of seahorses has traditionally relied on the supply of *Artemia* sp. and rotifers as first prey. However, copepods alone or supplemented with *Artemia* improved the rearing of seahorse juveniles. In order to ascertain ontogenetic feeding preferences in juveniles, three different preys (rotifer, *Artemia* nauplii and adult/copepodite *Acartia tonsa*) were tested. Rotifers were systematically rejected at all developmental stages, implying that is not a suitable prey for this seahorse species. Conversely, copepods and *Artemia* nauplii were actively captured since newborn release. However, the former were preferred over *Artemia* nauplii from 3 to 15 DAR, whereas the later were preferentially selected afterwards. The results on prey selection and mouth growth showed that juveniles would be able to ingest prey much bigger than those provided in our study (168 – 978 in length and 85 - 322µm in width), especially after 15 DAR. The presence of undigested and alive *Artemia* nauplii in feces from very young juveniles was accompanied by low growth rates, high mortalities and weakness of juveniles. This finding could be at least partially explained by the low chitinase activity recorded in the juveniles. On the contrary, copepods were efficiently digested. Digestive enzymatic activities recorded were very low, independently of the diet supplied (*Artemia* alone or supplemented with copepods). However, the activities increased in more developmental stages when copepods were included in the diet during the first days. Accordingly, a successful diet scheme for young *H. guttulatus* juveniles should include copepods during the first days for a better performance, especially if copepods are offered as the sole prey for at least the first 5 days after male's pouch release (G= 10% and 76% survival).

The results arisen from the present Thesis have allowed the development of a procedure for the early rearing of the seahorse *Hippocampus guttulatus*. The procedure is based on the use of pseudoKreisel aquaria, strong aeration (and an appropriate water inlet

placement) and a temperature of about 19°C under a 16L:8D photoperiod regime. The feeding scheme of that rearing methodology includes the use of copepods from 0 to 5 DAR, copepods + *Artemia* nauplii from 6 to 10 DAR and *Artemia* nauplii/metanauplii from 11 to 30 DAR. By the application of such a protocol the life cycle of *Hippocampus guttulatus* was closed after obtaining F2 juvenile batches. The availability of that methodology also permitted the introduction of *Hippocampus guttulatus* in the aquarium trade (high economical value) with stable production of juveniles, which is a need for future actions directed towards the reinforcement of wild populations.

Resum

Les poblacions salvatges de cavallets de mar es troben mundialment amenaçades degut a la pèrdua d'hàbitat, les captures accidentals i la pressió pesquera per la Medicina Tradicional Xinesa i el comerç per fins d'aquariofilia i souvenirs. La variabilitat en la resiliència dels cavallets a la disminució de les poblacions naturals va suposar la inclusió de totes les espècies de cavallets a la Llista roja d'Espècies en Perill de la IUCN al 1996. A més, totes les espècies es van incloure al 2002 a l'Apèndix II de la Convenció sobre el Comerç Internacional d'Espècies Amenaçades de fauna i flora silvestres (CITES). L'aplicació de mesures de conservació, com la cria en captivitat, es necessària com a solució potencial per garantir el benestar i la recuperació de les poblacions salvatges en disminució. Una producció aquícola eficaç hauria de desenvolupar protocols poc tecnològics de cria de cavallets per tal d'oferir un comerç viable assegurant objectius conservacionistes i, alhora, proveir d'un estil de vida alternatiu als pescadors de cavallets.

La present Tesi es focalitza en el cavallet de mar Europeu de nas llarg *Hippocampus guttulatus*. A Galícia, les poblacions salvatges d'aquesta espècie es troben sota una reducció demogràfica genètica a llarg termini. Els coneixements sobre el manteniment d'adults i juvenils de *H. guttulatus* en captivitat es va iniciar per primera vegada dins el Proyecto Hippocampus. Aquest projecte es va permetre establir un protocol de cultiu d'adults i assentà les bases del coneixement sobre la cria de juvenils.

Les millores en el cultiu d'adults mitjançant la incorporació de gambes (*Palaemonetes varians*) i misidacis (*Leptomysis* sp. i *Siriella* sp.) com a complement a la dieta i l'establiment de tècniques de cultiu per la manipulació de les condicions de captivitat, van millorar els aparellament. Aquestes millores van permetre els aparellaments durant tot l'any, la producció de nounats d'alta qualitat i una important reducció (de més del 95% al 6%) en la presència de nounats amb anormalitats o immadurs. Després de l'establiment de les condicions de cultiu d'adults, el següent pas en la producció de juvenils va esser el desenvolupament d'una tècnica de cria eficaç, objectiu principal d'aquesta Tesi.

La limitació de coneixements inicial sobre el cultiu de juvenils va resultar en baixes supervivències i mortalitats massives, la qual cosa va dificultar el descobriment del canvis essencials per obtenir una tècnica de cultiu fiable. A la present Tesi, es van aconseguir

importants millores a través de l'estudi de les tècniques de cultiu a diferents nivells: incloent-hi aspectes zotècnics (disseny d'aquaris), factors físics (intensitat d'aire, fotoperíode i temperatura) i d'alimentació (preferència de preses, tipus i talla de preses i capacitat digestiva).

El primer pas en el cultiu de larves de peixos és l'establiment d'un sistema de cria adequat, en el qual el disseny de l'aquari es essencial. El disseny d'un aquari adient que assegurés una distribució homogènia de les preses i dels juvenils a la columna d'aigua i l'establiment de nivells d'aire/turbulència idonis van resultar de gran importància per evitar tant l'accés del juvenils a la superfície de l'aigua com la presència de zones d'aigües estancades a l'aquari. Per reduir mortalitats no desitjades sota condicions òptimes s'ha d'evitar al màxim l'atapeïment superficial de juvenils, l'aparició de disfuncions en la bufeta natatòria i la ingestió accidental de bombolles d'aire. Així doncs, es van estudiar tres tipus d'aquaris diferents (rectangular, esfèric i pseudoKreisel) sota dues intensitats d'aire diferents (suau i forta). Es van obtenir millores significatives en cultius realitzats a aquaris tipus pseudoKreisel i aire fort. La supervivència mitjana a juvenils de 30 dies després de la alliberació (DDA) alimentats amb *Artemia* i copèpodes augmentà de 16-22 % a aquaris rectangulars i esfèrics fins a 69 % al pseudoKreisel. A més, els juvenils alimentats amb *Artemia* van mostrar tres vegades més supervivències quan es cultivaven amb aire fort comparat amb els cultivats amb aire suau. Així i tot, no es van trobar diferències significatives en la supervivència entre intensitats d'aire quan s'alimentaren amb dietes complementades amb copèpodes.

A part de la circulació i la turbulència de l'aigua a l'aquari, la fototaxis positiva del cavallets juvenils podria suposar la natació cap a la superfície de l'aigua. La incidència lateral de les llums i l'enfosquiment de la part superior de les parets de l'aquari va reduir la brillantor de la superfície i de les parets de l'aquari, i resultà essencial comparant-ho amb resultats anteriors.

El cavallets de mar son predadors visuals i, per tant, es va hipotetitzar que un fotoperíode continu (24h llum contínua) juntament amb la disponibilitat permanent de preses augmentaria les taxes de supervivència i creixement. No obstant, l'aplicació d'un règim de llum continu no va afectar al rendiment del cultiu comparat-ho amb cultius amb un fotoperíode de nit-dia (16h llum: 8h fosc).

Entre els factor físics potencialment lligats a l'èxit del cultiu, la temperatura n'és un dels més importants. Es van estudiar tres temperatures (15, 18, 20 °C) dins el rang de temperatures enregistrades anualment a les aigües superficials de la costa gallega. El creixement i la supervivència a 30 DDA van resultar en un desenvolupament sub-òptim de juvenils criats a 15 °C, temperatura no llunyana a la T_0 (límit inferior de temperatura a la qual el creixement és nul). A 18 i 20 °C, en canvi, es van aconseguir grans rendiments tant en creixement (8% i 11%, respectivament) com en supervivència (86 % i 81 %, respectivament). En aquest estudi es va demostrar per primer cop la idoneïtat dels Dies graus efectius (D^{eff}) com a escala de creixement independent a la temperatura per juvenils alimentats i es van obtenir models de creixement per temperatures entre els 14 i els 26 °C.

Els requeriments alimentaris i nutricionals es consideren un dels principals problemes en el cultiu de cavallets de mar. Les primeres etapes del cultiu han depès tradicionalment de l'ús d'*Artemia* sp. i rotífer com a primeres preses. En canvi, la incorporació de copèpodes com a presa única o complementant l'*Artemia* va millorar notablement el cultiu de juvenils. Per tal de determinar les preferències alimentàries ontogenètiques dels juvenils, es van provar tres preses diferents (rotífer, nauplis d'*Artemia* i adults/copepodits d'*Acartia tonsa*) Els rotífers van ser refusats sistemàticament durant tots els estadis de desenvolupament, implicant que es tracta d'una presa inadequada per l'alimentació aquesta espècie de cavallets. En canvi, els copèpodes i nauplis d'*Artemia* foren capturats activament des del moment de l'alliberació dels nounats. Els juvenils de 3 as 15 DDA, van capturar preferentment copèpodes, mentre que de 15 DDA al final de l'experiment els nauplis es van capturar preferentment. Els resultats obtinguts en la selecció de preses i en el creixement bucal van permetre demostrar que els juvenils serien capaços d'ingerir preses bastant més grans de les subministrades al present estudi (168 – 978 μm en longitud i 85 – 322 μm d'ample), especialment després de 15 DDA. La presència de nauplis d'*Artemia* no digerits i, fins i tot, vius als excrements dels cavallets primerencs estava associada a baixes taxes de creixement, elevades mortalitats i debilitat dels juvenils. Aquest fet es podria explicar, en part, per la baixa activitat quitinasa enregistrada a juvenils. Els copèpodes, en canvi, eren digerits eficaçment a totes les edats. Els enzims digestius estudiats presentaren activitats molt baixes, independentment de la dieta (*Artemia* sola o complementada amb copèpodes). En canvi, les activitats enzimàtiques a estadis de desenvolupament avançats van ser més elevades quan es van subministrar copèpodes durant els primers dies de vida. En aquest sentit, un bon esquema alimentari per un millor rendiment del cultiu de juvenils d'*H. guttulatus* hauria d'incloure copèpodes durant els primers dies,

especialment si els copèpodes es subministren com a única presa de 0 a 5 DDA (G=10 % i 76 % de supervivència).

Els resultats obtinguts a la present Tesi han permès el desenvolupament d'un procediment de cultiu de cavallets *Hippocampus guttulatus*. El protocol es basa en l'ús d'aquaris pseudoKreisel i aire fort (i d'un posicionament apropiat de l'entrada d'aigua), a una temperatura aproximada de 19 °C sota un fotoperíode de 16L:8F. L'esquema alimentari d'aquesta metodologia de cultiu inclou l'ús de copèpodes de 0 a 5 DDA, copèpodes + nauplis d'*Artemia* de 6 a 19 DDA i nauplis/metanauplis d'*Artemia* d'11 a 30 DDA. Mitjançant l'aplicació d'aquest protocol, es va tancar el cicle de vida d'*Hippocampus guttulatus*, produint varies ventrades de juvenils de segona generació F2. Aquesta metodologia ha permès la introducció dels *Hippocampus guttulatus* en el comerç d'aquarofília (elevat valor de mercat) i una producció estable de juvenils, necessari per futures accions dirigides al reforçament de les poblacions salvatges.

1. INTRODUCTION

A flag-ship species

The “Hippokampos” (fish-tailed horses) belong to a group of ancient greek mythological creatures such as the "Leokampos" (fish-tailed lion), "Taurokampos" (fish-tailed bull), "Pardalokampos" (fish-tailed leopard), and "Aigikampos" (fish-tailed goat). All of them share the common characteristic of having the foreparts of land animals and a fish serpentine tail, which might remind to the most famous representation of “Satyroi”, worldwide known as mermaids.

The name Hippokampos, derived from the greek words Hippos-, and -kampos, which literally means horse-monster. Traditionally, the representation of “Hippokampos” consisted of a horse and, the part of its body down from the breast, a sea monster or fish (Smith, 1870). From then, seahorses have become an inspiration and a symbol for many cultures being represented in the literature and in uncountable objects as well, considering the sea-horses monsters as the symbol of Poseidon, whose chariot, according to Homeric poems, was ploughed through the sea by swift horses. The first known seahorse physic representations are a brooch of King Croesus hoard, dated from the sixth century B.C. (Waxman, 2008), and a coin of the Israel Yizre'el Valley Silver Hoard from the fourth century B.C. in which god Melqarth is depicted riding into the waves on a winged hippocampus (IAA, 1981), which suggest that seahorses were considered a symbol of fortune, power and strength.

Evolutionary Traits of Seahorses

The Family Syngnathidae (Syngnathids) is included in the Order Syngnathiformes and comprises seahorses (*Hippocampus* sp.), pipefishes, pipehorses and seadragons. The oldest fossils (Figure 1.1) found of seahorses were dated from the Middle Miocene (lower Sarmatian) Coprolitic Horizon in Slovenia (Žalohar et al., 2009). Evolutionary processes converted a regular shaped fish into a fish that does not look like a fish. One of the morphological characteristics used for the taxonomical grouping of Syngnathids is the fusion of cranial and feeding structures.

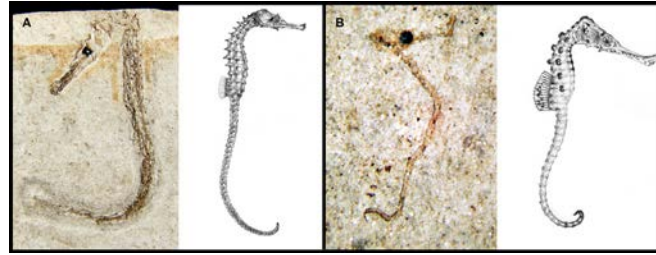

Figure 1.1. Seahorse fossils found in the Coprolitic Horizon (Slovenia) dated from the Middle Miocene (lower Sarmatian) (Žalohar and Hitij, 2012). A) *Hippocampus sarmaticus*. B) *Hippocampus slovenicus*

This group of fishes defined the Order Syngnathiformes, which literally means “together-jaw shaped” in a mixed word of greek-latin origin. *Syn* and *gnathos* means “together” and “jaw”, respectively, in Greek and *-formes* means shape in Latin. Therefore, a common feature of this group of fishes is that all families included have fused jaws. Due to these special characteristics, this wide group of fishes has a common feeding strategy, with suction feeding, in which a buccopharyngeal expansion generates water current that draws down to the mouth prey failing to escape (Roos et al., 2009a, 2010; Van Wassenbergh et al., 2013). These fishes are specialized suction feeders with one of the most extreme cranial morphologies in teleost fish (Roos et al., 2009a, 2010; Van Wassenbergh et al., 2013). Their feeding apparatus is formed by a small mouth, located at the tip of what is widely known as snout (Figure 1.2 and 1.3), and an elongated neurocranium which rotates with the head in order to optimize the pivot-feeding strategy of the Syngnathids (Roos et al., 2010; Žalohar and Hitij, 2012).

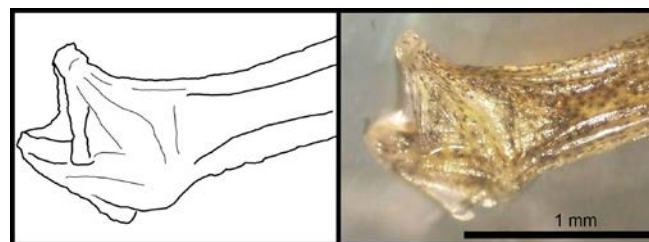

Figure 1.2. Snout of 20 DAR seahorse juvenile *H. guttulatus* reared in captivity at the IIM-CSIC facilities.

Pivot-feeding encompasses a high-speed rotation of the head and, when the distance between the mouth and the prey is minimal, a buccal expansion creates a suction current that allows to capture a prey in approximately 6ms (Leysen et al., 2011c). The relative 90 degrees angle that forms the head and the body trunk allowed seahorses to increase the strike distance during feeding, increasing the water volume influenced by suction and, therefore, the potential for prey capture (Van Wassenbergh et al., 2011).

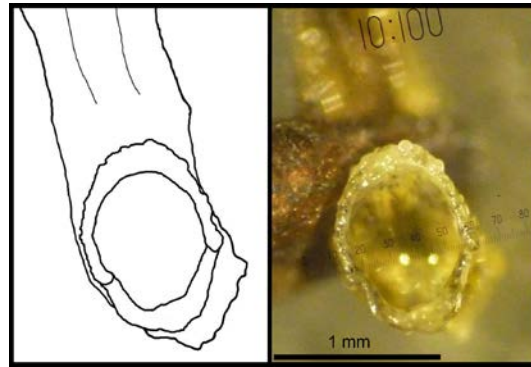

Figure 1.3. Mouth detail of 15 DAR seahorse juvenile *H. guttulatus* reared in captivity at the IIM-CSIC facilities.

Suction feeding is a four steps process (Roos et al., 2009a). In the first step, called Preparation, a compression of the buccal cavity decreases its volume. In the second step, or Expansion, a quick mouth opening is produced by hyoid rotation or through the coupling between the lower jaw, the interhyal and the operculum. Hence, the cranium rotates dorsally increasing the internal buccal volume and, subsequently prey and the surrounding water is sucked. During Compression, the third step, the fish closes the mouth and the buccal cavity volume decreases again, allowing the water sucked to flow out through the gill arches. In the last step, named Recovery, the fish return their skeletal elements to their original position.

Syngnathidae evolution has proven to provide most studied members of the family with an unusual ocular characteristic, a foveal specialization (Lee and Bumsted O'Brien, 2011). The existence of a *fovea centralis* has been related to retinal imaging magnification, accurate fixation and directional focusing. Retinal pigments and the number of photoreceptor cells in the slope of the fovea also has been suggested to improve color discrimination and motion detection (Mosk et al., 2007), as well as foraging acuity (Lee and Bumsted O'Brien, 2011). Additionally, independently moving chameleon-like eyes of Syngnathidae (Figure 1.4) provides an exclusive support for their unique retina (Fritsches and Marshall, 2002).

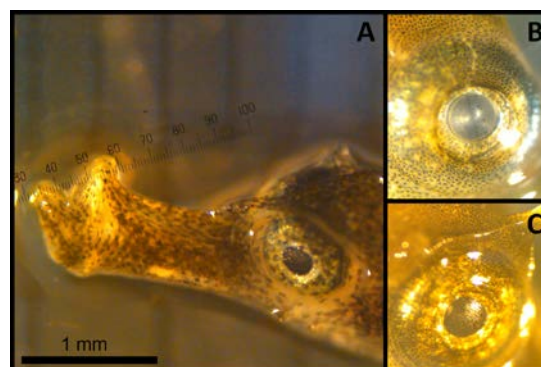

Figure 1.4. Head of an *H. guttulatus* newborn (A) and detail of 66 DAR dead juveniles (B and C) reared at the IIM.

In their study, Fritsches and Marshall (2002) used a pipefish as representative of the Syngnathidae family and pointed out that it could activate selectively fixation and pursuit or optokinetic stabilization after a blurred imaging event. This feature (only described in pipefishes, sand-lances and chameleons) provides the capacity to independently direction their eyes at different speeds when two preys are into their line of sight as well as to use forward locomotion of the eye in order to stabilize a blurring background, which makes seahorses an excellent predator. On the other hand, Lee and Bumsted O'Brien (2011) studied the number of retinal photoreceptors and ganglion cells by mapping their topography in the retina of two species of adult *Hippocampus* inhabiting different environments. Their findings suggested that visual acuity might be related to more turbid environments and necessary for small prey hunting.

Seahorses are ambush predators that usually grasp on holdfast while hunting (Vincent, 1996; Curtis and Vincent, 2005; Roos et al., 2010). Holdfast holding has evolved in Syngnathids by the disappearance of the caudal fin into a powerful prehensile tail (Žalohar and Hitij, 2012), a trait that effectively helped Hippocampinae (subfamily that include seahorses and pipehorses) during feeding strike and enhanced stabilization during strong water currents (Žalohar et al., 2009; Praet et al., 2012). Evolutionary prehensile tails of pipehorses and seahorses are unique among fishes. The tail is an extension of the vertebral column covered by a chain of articulating rigid bony plates which has been in the interest of biomechanical and biomedical studies (Kanou and Kohno, 2001; Van Cauter et al., 2010; Praet et al., 2012; Porter et al., 2013). That “bony plated armor” is tough enough to ensure a protective role from potential fractures or crushing, and sufficiently elastic and flexible to allow control over axial bending and prehension (Porter et al., 2013). On the counterpart, the disappearance of the caudal fin leads seahorses and pipehorses as the slowest swimming fish worldwide (Garrick-Maidment, 2004).

The split between seahorses and pipehorses during Late Oligocene has been determined using a relaxed molecular clock, setting older dates as upper bounds (Figure 1.5). During that period, seahorses acquired an upright position, a distinctive characteristic that provided them good camouflage during seagrass expansion and a later improvement of their feeding system (Teske and Beheregaray, 2009; Van Wassenbergh et al., 2011). The upright position of seahorses is the only morphological difference with pipehorses (Žalohar and Hitij, 2012), which was confirmed by a fossil pipehorse from the Coprolitic Horizon in Slovenia

dated in the middle Miocene, suggested as an intermediate group between seahorses and pipefishes. The upright position of the horse-like headed fishes, *Hippocampus*, has been related to their ambush behavior, allowing an effective capture angle and high speeds to successfully hunt on prey from the back while either being driven by water currents or holding natural/artificial fixed structures (James and Heck Jr, 1994; Felício et al., 2006; Van Wassenbergh et al., 2011) or hiding in bare substrates (Curtis and Vincent, 2005).

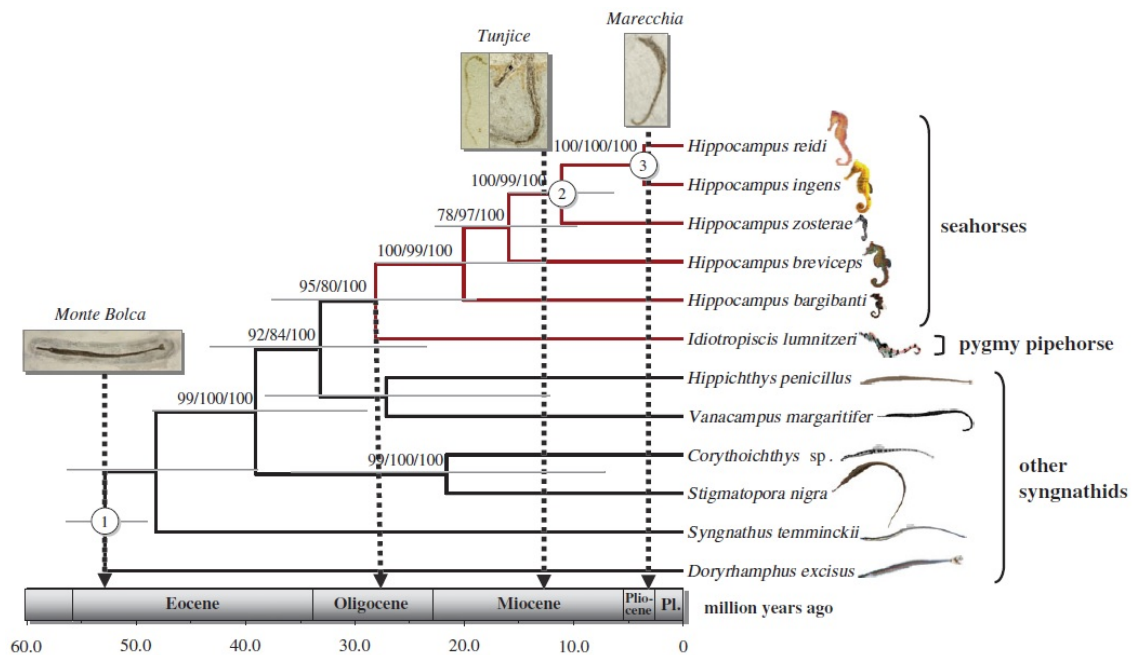

Figure 1.5. Geological time scaled chronogram of the family Syngnathidae reconstructed from DNA sequence data of seahorses, and other species representing the major genetic lineages of the family. Extracted from Teske et al. (2009).

In addition of a modified, bony and prehensile tail, Hippocampinae fishes share other evolutionary characteristics such as the development of a brood pouch in males (Žalohar and Hitij, 2012). The relative position of the eggs in the body, as well as the location and development of the male pouch has been used as a primary taxonomic discern for grouping of Syngnathidae (Wilson et al., 2001):

- A) *Entelurus* and *Nerophis*. Inexistent proper brood pouch that led unprotected eggs loosely attached to the ventral side of the male.
- B) *Solegnathus* and *Doryrhamphus*. Males possess membranous egg compartments.
- C) *Oostethus*. Well-defined pouch protected by pouch plates ventrally derived from the lateral plates of the trunk or tail rings in which eggs are incubated.

D) *Syngnathus*. Males have a well-defined pouch in which eggs are partially or fully enclosed. It is formed by bilateral folds extensions that meet on the ventral midline.

E) *Hippocampus*. Males incubate the eggs in a completely enclosed saclike pouch with an anteriomesial/central pore near the abdomen (Figure 1.6), which provides an optimum environment for developing embryos by changing fluid pressure from bloody to seawater densities (Linton and Soloff, 1964). Nutritional, respiratory and osmorregulatory processes have been also designated (Carcupino et al., 2002).



Figure 1.6. Pouch of a dead pregnant male with undeveloped embryos (n = 187)

In fact, Syngnathidae is a large family sharing one of the rarest reproductive strategies: male pregnancy. This is a worldwide known characteristics understanding pregnancy as the process in which the incubation of developing embryos occurs inside the body after egg-sperm union (Stölting and Wilson, 2007). Many families of fish have entrusted males during parental care. Syngnathids had crossed the line and lead males to fertilize and incubate the eggs that females have deposited in the male's specialized brooding area or brood pouch (Figure 1.7). Although pipefishes and seahorses have developed the most advanced brooding structures of their common family, they have evolved independently comparing the relative position of their brooding structures (Wilson et al., 2001). The genus *Hippocampus* is considered a 15M years old taxonomic group that evolved independently (Žalohar et al., 2009), reaching the greatest developmental complexity of Syngnathidae (Wilson et al., 2001; Carcupino et al., 2002).



Figure 1.7. Isolated pregnant male one day prior to juvenile release.

Similarities during Syngnathids development can be classified in four periods including eleven stages (Figure 1.8):

1- Early embryogenesis: This first developmental period is divided in four stages, zygote, early cleavages, embryonic shield and primitive streak. This period extends from egg activation after fertilization until embryo emergence on top of the yolk as a primitive streak.

2- Eye development: As already described, visual characteristics of seahorses are highly unusual. Therefore, it does not seem illogical that the development of the eye started as a conspicuous trait after the primitive-streak embryo stage. During this period three stages may be differentiated: optic vesicles, as semispherical structures; optic cups, in which two-layered eye structures are formed (the neural and the pigmented retina); and, eye pigmentation, in which the first body pigments become visible. After this period, the embryos in fully-developed pouch species hatch and continue their development inside the brood pouch without the egg shell whereas in open-brooding species the embryos do not hatch and continue their development inside the egg.

3- Snout formation: The development of a snout and the fusion of the jaws is a critical point during juvenile embryogenesis. During this phase, the yolk sac progressively disappears and three different stages might be considered: ventral jaws formation, frontal jaw development and protruding snout stage. The jaws firstly develop horizontally and later vertically to the dorsoventral axis and, prior to reach the middle of the eyes, the snout elongation resulted in a protruding adult snout.

4- Juvenile: A miniature of the adult seahorse is fully formed with no signs of yolk sac and readily to swim and feed.

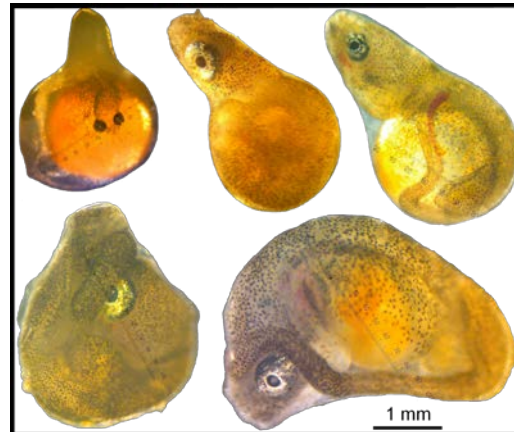

Figure 1.8. Expelled *H. guttulatus* embryos at different developmental stages from discarded fry by pregnant males in captive batches.

Mating characteristics in Syngnathids include sex-role reversed polygamy in pipefishes, and non sex-role reversed monogamy in both pipefishes and seahorses (Vincent et al., 1992). In species with polygamy, male pregnancy last for longer than the average time for a female to produce a new clutch of eggs and, therefore, females have multiple sex partners. On the other hand, in some cases both males and females have multiple mates during male pregnancy, which progressively reduce their physiological conditions and larger refractory periods in between pregnancies are needed (Vincent et al., 1992). Monogamy of seahorses was firstly described in 1994 and it has been proven to be genetically encoded (Vincent et al., 1994; Jones et al., 1998; Kvarnemo et al., 2000; Wilson and Martin-Smith, 2007). Shorter courtships and larger pregnancies have been reported with no physiological decline neither differences in the refractory periods found (Vincent et al., 1994; Vincent and Sadler, 1995). Seahorse unique reproduction system is also a synchronized process of male availability and female egg-hydration, in which the female mature the eggs a few days before a suitable brood pouch is available [3 days, as it has been described for *Hippocampus guttulatus* (Naud et al., 2009)]; when no male is available, the female would reject the whole clutch. Egg quality determines suitability of an egg to be fertilized and develop into a normal embryo, which might be affected by a wide variety of environmental and biological factors compromising the oogenesis.

Fish abnormalities during embryogenesis are common; however, regarding Syngnathids only snout abnormalities and twinning have been slightly described (Cable, 1940; Planas et al., 2009c; Blanco et al., 2012) (ANNEX D).

General Traits of Seahorses

The family Syngnathidae has been widely studied and two phylogenetic discrepancies emerged based on their morphological and genetic characteristics (ITIS, 2013; Fishbase, 2014). Despite species database inconsistency, the genera *Hippocampus* and *Syngnathus* encompass the majority of the species of the family. All seahorse species are included in the genus *Hippocampus*, representing up to 20% of the whole family according to ITIS (Interagency Taxonomic Information System) or to 17% considering the Fishbase.org database.

The genus *Hippocampus* is a controversial group in which high variability exists in the exact total number of species. According to ITIS there are up to 72 species of seahorses (ITIS, 2013) whereas only 54 species are reported in FishBase database (Fishbase, 2014), 47 species are recognised by Project seahorse (ProjectSeahorse, 2014) and only 38 species are listed by IUCN (International Union for Conservation of Nature). Despite taxonomical discrepancies, all seahorses possess similar body shapes (Figure 1.9) with elongated snouts, horse-like heads, bony plates substituting scales, ringed trunks, prehensile tails, small pectoral and dorsal soft-rayed fins, gill-openings reduced to a small round pore and un-teethed jaws (Lourie et al., 1999; Kuitert, 2000).

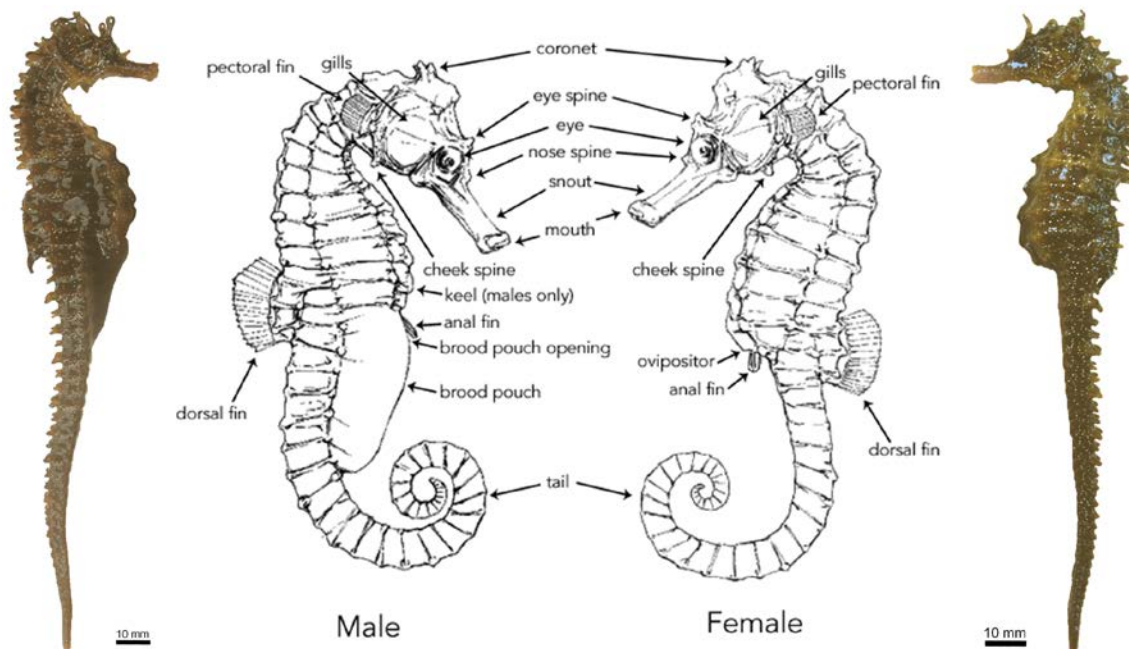

Figure 1.9. Male (left) and female (right) long-snout seahorse *H. guttulatus*, anatomic drawing representation of *H. kuda* extracted from Choo and Liew (2006).

Fins are used for swimming and manoeuvring. The dorsal fin moves rapidly from top to bottom and allows the forward-backward movements of the seahorse (Breder and Edgerton, 1942). The pectoral fins are used for up and down displacements while the relative position head-tail permits to balance the seahorse centre of gravity (Breder and Edgerton, 1942; Kuitert, 2000). However, the holding nature of seahorse's tail is in accordance with their sedentary behaviour.

Seahorses are diurnal and carnivorous, preying primarily on small crustaceans (Vincent, 1996; Kuitert, 2000; Olivotto et al., 2011). Each species have a preferred habitat that provides the optimum opportunity for food and gives them the best protection. The natural diet of seahorses in the wild is commonly based on amphipods, copepods, fish larvae and other small crustaceans (Vincent, 1996). However, despite their retinal cells, seahorses are not UV-sensible, which is a common characteristic of planktivorous fishes (Mosk et al., 2007). Planktivorous foraging has been described in wild seahorses and seems to be species-specific in nature. The adults of *Hippocampus guttulatus* and *H. hippocampus* in the Aegean Sea feed preferentially on Amphipoda, Anomura Decapoda and Mysidacea (Kitsos et al., 2008). Harpacticoid copepods are the mostly eaten prey by wild adults of *H. zosterae*, *H. subelongatus* and *H. reidi* (Tipton and Bell, 1988; Kendrick and Hyndes, 2005; Castro et al., 2008) whereas Cyclopoida and Calanoida copepods and Caridean shrimps are the mostly consumed prey by *H. abdominalis*, *H. mohnikei* and *H. breviceps* (Kanou and Kohno, 2001; Woods, 2002; Kendrick and Hyndes, 2005). Amphipods are the preferred prey for adult *H. erectus*, being copepods important in the natural diet in juvenile stages (Teixeira and Musick, 2001).

Differences in prey preference of seahorses have been related to their ambushing conduct so that active or sedentary behaviors could reflect the preferred type of food. Sedentary Syngnathids would preferably feed on epibenthic and planktonic prey (Castro et al., 2008) while more active ones would hunt mainly on the sediment or in the phytal canopy (Kendrick and Hyndes, 2005). Such behaviors have been found in sympatric species occurring in the Ria Formosa (Curtis and Vincent, 2005) where both European seahorse species, *Hippocampus guttulatus* and *H. hippocampus*, coexist with different use of their respective niches, which is reflected in the feeding behavior of adults.

Seahorses are found worldwide, except in cold-temperate and polar seas (Kuitert, 2000), approximately from 50°N to 50°S (Lourie and Vincent, 2004). Temperate seahorse

species are generally encountered inhabiting vegetated habitats (Curtis and Vincent, 2005). Seagrass/seaweed habitats are marine biotopes dominated mainly by *Cymodocea* spp, *Zoostera* spp, *Ulva* spp, etc. Seahorses are also found among corals, mangrove, estuaries, and open sandy or muddy bottoms (Bell et al., 2003; Lourie and Vincent, 2004). Such heterogeneity provides seahorse communities with the opportunity to share niches sympatrically over multiple spatial scales (Curtis and Vincent, 2005; Smith et al., 2012). Latitude, in terms of photoperiod and temperature, has been related to many life-history variables as is known to affect physiological functions such as female maturation (Planas et al., 2010a, 2013), breeding capacity (Lockyear et al., 1997) or gonad development (Wong and Benzie, 2003; Lin et al., 2006).

Sexual maturity of males is easily recognized and inferred from the developmental stage of the brood pouch, which encompass a process of firstly pigmentation of the zone followed by a slit among folds of tissue. Then, the small pouch flushes with the tail and continue growing to form an empty mature pouch that will be later fully mature while testes develop and mature (Curtis and Vincent, 2006). Seahorses have long and elaborated courtship displays that culminate with the male incubating the eggs within a brood pouch (Masonjones and Lewis, 1996; Sommer et al., 2012). Seahorse courtship is a rather similar ritual among species (Woods, 2000b; Planas et al., 2008b) in which male and female start “dancing” by flexing tails and bending their bodies. Males repeatedly inflate and open the brood pouch as a sexual claim. When both members of the pair are responsive, they start “dancing” up and down repeatedly in the water column by swimming in circles in side by side positions while the male continues opening the brood pouch bending the tail towards the body. Finally, the female faces the male and places her genital papilla inside the opening pore of the male pouch to transfer the eggs. Simultaneously the male fertilizes the eggs while entering (Faleiro et al., 2008). At birth, which equally occurs at night or afternoon (Faleiro et al., 2008), the male’s contractions (flexing the tail towards the body repeatedly) force the juveniles to leave the brood pouch.

Conservation Status and Aquaculture

Although the extinction of marine fish has traditionally been considered to be unlikely, in the last two decades 29 species of fish have extinct locally (93%), regionally (3.5%) or globally (3.5%). Extinctions are mainly due to habitat destruction/loss (59%), exploitation

(24%) or both simultaneously (17%). Two of those extinctions corresponded to a local disappearance of Syngnathid species due to habitat loss (Dulvy et al., 2003). One of them is the most common pipefish species (*Syngnathus thyphe*) in the Wadden Sea (Wolff, 2000). Human activities in the coasts and increasingly fast tendency to occupy coastline areas has aggravated and accelerated that process (Caldwell, 2012). Traditional Chinese Medicine (TCM), habitat destruction, by-catch and curios trade are the main threats at which seahorses are exposed (Vincent, 1996). Overall, more than 20 million tones of seahorses were estimated to be traded yearly around the world. Seahorses might be very resilient or highly vulnerable to population declines due to their life history characteristics (Caldwell and Vincent, 2012).

The first seahorse species included in the International Union for Conservation of Nature (IUCN) Red List was *H. capensis* in 1988 (IUCN, 2014), which was classified as 'Vulnerable'. In 1996, as a result of a wide worldwide study on seahorse threats, population stock and status (Vincent, 1996), all seahorse species were included in the Red List of Endangered Species of the IUCN, 88% of them as 'Vulnerable' and the rest as 'Data Deficient' (DD) (IUCN, 2014). After a revision on the populations status in the 2000s and the inclusion of other species newly discovered, *H. capensis* was the first listed species as 'Endangered' and most of the species changed their 'Vulnerable' status to DD. In 2010, *H. sindonis* improved from DD to a 'Least Concern' status. Finally, the last update of the Red List in 2012 listed 10 species as 'Vulnerable', 26 species as DD, 1 species as 'Endangered' and 1 species as 'Least Concern'. Additionally, in 2002, all species were also included in the Appendix II of The Convention on International Trade in Endangered Species of Wild Fauna and Flora (CITES, 2002), which has been effective since 2004. Species listed in Appendix II of CITES are allowed to be traded; however, exporting countries are required to ensure wild populations.

Seahorse aquaculture is of main importance and considered a potential solution to guarantee wild population welfare while providing a commercially viable trade (Prein, 1995; Vincent, 1996). Until recently, seahorse culture publications were limited to amateur aquarium hobbyists (Woods, 2007) although few research efforts were already done (Herald and Rakowicz, 1951; Correa et al., 1989). Attempts on breeding and rearing seahorses in Asia from 1957 until 1990's failed, mainly due to economic challenges of large-scale facilities and disease/nutritional problems related to confinement (Chen, 1990; Prein, 1995; Koldewey and Martin-Smith, 2010). Prior to initiate conservation concern operations, field impacts must be

assessed and wild populations threats studied and managed. Accordingly, those operations should rely in the minimum number of wild animals needed to maintain captive broodstock genetically healthy (Koldewey and Martin-Smith, 2010). Conservation operations aim to enhance the long-term survival of a species by re-establishing keystone species in an ecosystem, maintaining natural biodiversity and/or providing long-term economic benefits while promoting conservation awareness (FAO, 2014). The release of captive seahorses to the wild and further monitoring and assessment require long-term financial, political, and local support in order to ascertain no biological risks on wild seahorse populations and marine ecosystems (Vincent, 1996; Tlusty, 2002).

Several studies on seahorse species have been focused on biological/ecological characteristics and the acquisition of field data (Gill, 1905; Fish, 1953; Strawn, 1958; Herald, 1959; Blake, 1976; Tipton and Bell, 1988; James and Heck Jr, 1994; Vincent, 1990; Selman et al., 1991; Matlock, 1992; Vincent et al., 1992), physiological parameters (Peters, 1951; Fiedler, 1970) and exploitation – threat status (Marichamy et al., 1993; Whitfield, 1995; Vincent, 1996). Positive benefits from seahorse aquaculture will only excel if demand remains relatively constant, switching from wild to cultured animals, minimizing negative environmental impacts and maximizing local socioeconomic benefits (Job et al., 2002; Martin-Smith and Vincent, 2006; Vincent and Koldewey, 2006). Surprisingly, although studies on captive-bred seahorses aimed their culture to relief the overfishing pressure on wild population, only one species (*Hippocampus comes*) has been reported to be commercially produced to supply the TCM (Koldewey and Martin-Smith, 2010; FAO, 2014). It is essential to develop low-technology protocols for seahorse culture (Vincent, 1996) in order to provide a useful tool that both reduce the demand of wild-caught and provide an alternative livelihood to fishers in wild-seahorse source countries. Therefore, ensure both the fisher's annual income and reduce the pressure upon wild populations (Vincent, 1996; Wilson and Vincent, 2000; Job et al., 2002).

Aquaculture activities started in Asia around 2,500 B.C., as a practice to supply food to meet the farmer's personal needs, both directly as food and indirectly as catering in local markets. The increasing value of fish and the profit that traders were gaining in local markets enhanced the farming of high market valued species in the 1960s by the Japanese, taken up later and further developed in Europe, USA, and Australia (Sorgeloos, 2013). Despite commercialized fish for food, aquaculture includes other productions such as ornamental fish, among others (FAO, 2014), either for aquarium trade or to rebuild wild populations.

The importance of aquaculture has increased considerably and by the 1970s it was already proposed as an alternative to meet the global demand of fish for food and therefore alleviate the pressure on traditional fishery captures which have been depleted as a result of overfishing, pollution and habitat destruction. Ornamental aquaculture has not been included in the database/dataset of global aquaculture production by FAO because ornamental species production is mostly measured by the number of individuals instead of weight/ biomass, although size matters, too, for some species. Additionally, there are certain live aquatic ornamental products, such as live rocks and aquatic macrophytes, which still remain ambiguous in their classification (Zhou, FAO statistics, personal communication). The value of total international exports of ornamentals has yearly increased about 14% in the last 30 years, with only about 2% in reared marine species (Bartley, 2000). Those tendencies indicate that captive reared specimens are luxury items mainly consumed/traded by developed and highly capitalized countries in which hobbyists can pay high prices for a single individual. Additionally, a huge proportion of those traded species usually originates from developing countries with low salaries (Job et al., 2002), which inflates the margin of benefit for sale.

Traders, conservationists and policy makers have all different objectives from the aquaculture production; ones try to maximize their profits, the others to ensure healthy environments, and the later to develop suitable legislation to meet both objectives (Olivotto et al., 2011). Successful operational aquaculture must offer cheaper captive bred seahorses than wild-caught specimens (Vincent, 1996), and therefore production costs need to be extremely low. Fortunately, seahorses are relatively valuable in marine ornamental aquarium trade since they can be more attractive to buyers because supply and price stability (Koldewey and Martin-Smith, 2010). However, the highly price of captive-bred seahorses mainly happen in developed countries, where most consumers would pay more for those seahorses but not so in developing countries such as Singapore, where wild-caught seahorses can reach very cheap prices (0.50-1.50\$ each) and bycatch captures implies no direct costs. In developed countries, it is estimated that hobbyists are willing to pay more for captive-bred seahorses as they are better adapted to an *ex-situ* environment, to a widely available feed regime rather than live-wild prey and, additionally, offer a wide range of sizes and specially selected attractive coloration patterns (see Table 1).

Table 1. Sale price of different seahorse species and morphotypes by seller country.

Species and variety	Price	Seller	Source
<i>Hippocampus erectus</i> var Red Fire	332€	USA	www.seahorse.com
<i>Hippocampus erectus</i> var Pintos	332€	USA	www.seahorse.com
<i>Hippocampus whitei</i>	332€	USA	www.seahorsecorral.com
<i>Hippocampus reidi</i> var Leopard	112€	Spain	www.tiendadecaballitos.com
Australian <i>Hippocampus kuda</i>	74€	USA	www.liveaquaria.com
Yellow <i>Hippocampus kuda</i>	65€	UK	www.aquaticstoyourdoor.uk

However, as wild specimens are still being sold in developed countries at a cheaper price than captive-bred due to their low capture-cost (18 € for *H. erectus* or 5 € for *H. zosterae* in USA, <http://mysaltwaterfishstore.com>; or 18€ for a pregnant *H. zosterae* in USA, www.aqualand.com), conservation aquaculture objectives are almost impossible to achieve (Vincent and Koldewey, 2006). Therefore conservation effort should also focus on meet market demand; otherwise, trade prices may increase and fishers would return to wild-caught practices (Tlusty, 2002).

Captive Rearing of Seahorse Juveniles

One of the problems that seahorse aquaculture has to face is the strong dependency on wild population and not vice-versa (Tlusty, 2002). In fact, pregnant wild-caught males as a source of viable fry are commonly used in the culture of seahorse juveniles to successfully close their life-cycle (Wilson and Vincent, 2000; Hora and Joyeux, 2009; Murugan et al., 2009). Up to 6 seahorse species (*H. abdominalis*, *H. kuda*, *H. ingens*, *H. zosterae*, *H. capensis*, and *H. whitei*) have been reported to be successfully raised to adulthood and shipped around 45 countries worldwide since 1996. Although captive second generations have not been mentioned (Burhans, 2004), there are several commercial companies operating successfully. Seahorse culture has been historically considered very difficult and strong efforts have been undertaken during the last decades. Information gaps on husbandry and health management practices are still of main interest to successfully breed and rear seahorses (Koldewey and Martin-Smith, 2010). Recently, significant advances have been made in seahorse rearing techniques, which have been developed and improved for some species.

Feeding and nutritional requirements have been considered a main bottleneck in the culture of seahorses (Vincent and Koldewey, 2006; Koldewey and Martin-Smith, 2010; Olivotto et al., 2011). Juvenile seahorses are obligate predators that ambush on live prey (James and Heck Jr, 1994; Felício et al., 2006; Thuong and Hoang, 2013). Unfortunately, live food culture is time consuming, expensive and requires special equipment and consumables (Koldewey and Martin-Smith, 2010). The traditional feeding scheme is commonly based on the use of *Artemia* nauplii, the rotifer *Brachionus plicatilis* and, less frequently, copepods. However, low digestibility of *Artemia* nauplii during early developmental stages has been described (Payne and Rippingale, 2000; Planas et al., 2009; Olivotto et al., 2011). The use of copepods alone or supplemented with *Artemia* has been reported to improve the rearing of juveniles, probably due to a higher digestibility of the former during first feeding (Payne and Rippingale, 2000; Sheng et al., 2006; Olivotto et al., 2008). Therefore, supply of sufficient and adequate prey is essential for its detection and capture by seahorse juveniles and therefore to ensure optimal growth and survival during rearing (Herwig, 1980; Shaw et al., 2003; Martínez-Cárdenas and Purser, 2007; Lee and Bumsted O'Brien, 2011; Souza-Santos et al., 2013).

Traditionally, intensive marine fish cultures have been carried out with diets based on *Artemia* nauplii which usually need further enrichment, especially in *n-3* highly unsaturated fatty acids, to fulfill the nutritional requirements of seahorse juveniles (Lockyear et al., 1997; Woods, 2000a, 2003a, 2003c; Chang and Southgate, 2001; Sales and Janssens, 2003; Martínez-Cárdenas and Purser, 2007; Yin et al., 2012). Some enrichment diets have been experimentally tested to enhance survival and/or growth performance (Chang and Southgate, 2001; Shapawi and Purser, 2003; Wong and Benzie, 2003; Palma et al., 2011; Pham and Lin, 2013). However, the nutritional deficiencies of *Artemia* nauplii (even when enriched) as first feed diet have been widely discussed, especially when compared to the higher nutritional quality of copepods (Shields et al., 1999; Payne and Rippingale, 2000; Wong and Benzie, 2003). In fact, copepods have been included in the feeding schedule of young juveniles as unique or supplementing prey for the early feeding of *Hippocampus barbouri*, *H. fuscus* (Wilson and Vincent, 2000), *H. erectus* (Gardner, 2008), *H. kuda* (Anil et al., 1999; Wilson and Vincent, 2000; Sheng et al., 2007; Thuong and Hoang, 2013), *H. reidi* (Olivotto et al., 2008; Hora and Joyeux, 2009; Pham and Lin, 2013), *H. subelongatus* (Payne and Rippingale, 2000) and *H. trimaculatus* (Sheng et al., 2006, 2007; Murugan et al., 2009).

Studies on the biochemical composition, including fatty acids, have been carried out at different developmental stages of *H. kuda*, *H. guttulatus*, *H. hippocampus*, *H. abdominalis*, *H. trimaculatus*, *H. kelloggi*, *H. spinosissimus*, *H. histix* and *H. comes* (Chang and Southgate, 2001; Choo and Liew, 2006; Lin et al., 2008; Lin et al., 2009; Faleiro and Narciso, 2010, 2013; Otero-Ferrer et al., 2010; Planas et al., 2010a; Saavedra et al., 2013; Thuong and Hoang, 2013).

Seahorses possess a simple intestine duct with no functional stomach which might difficult digestion (Wardley, 2006; Palma et al., 2013). However, developmental increasing complexity of the digestive tract implies changes in the digestion and assimilation of the ingested preys (Walford and Lam, 1993; Kim et al., 2001; Wardley, 2006). Ontogenetic changes in diet schedule are essential to successfully achieve prey preference and the optimal prey size of juvenile seahorses during their development. Studies on prey preference and selectivity in early developmental stages are scarce (Payne and Rippingale, 2000; Sheng et al., 2006; Celino et al., 2012; Souza-Santos et al., 2013), though all of them highlighted the importance of dietary changes with juvenile development.

The fulfillment of fish needs requires the understanding of biological and physiological constraints that young fish might face in the rearing system such as environmental factors that could affect the rearing success. In this sense, prey distribution in the aquaria plays an important role on the feeding success of seahorse juveniles. Aquaria design and aeration affect to water movement pattern which might cause the presence of dead volumes and bypass currents which may compromise fish wellness (Duarte et al., 2011) and, also, a non-homogeneous distribution of prey. Accordingly, different aquaria designs have been used for the rearing of seahorse juveniles, including the traditional rectangular shaped aquarium (Lin et al., 2006; Gardner, 2008; Olivotto et al., 2008; Otero-Ferrer et al., 2010) and spherical/circular (Wilson and Vincent, 2000; Woods, 2000a, 2003a, 2003c; Sheng et al., 2007), or more specialized shapes such as bamboo cages (Garcia and Hilomen-Garcia, 2009; Garcia et al., 2010), plastic buckets (Sheng et al., 2006), conical-cylinder (Payne and Rippingale, 2000; Wardley, 2006) or pseudoKreisel aquaria (Burhans, 2004; Koldewey, 2005). Therefore, the achievement of a proper aquaria design is essential to ensure an optimal growth and survival of seahorse juveniles, at least during early development.

The importance of defining ideal environmental factors such as temperature and photoperiod regimes falls on the optimization of breeding and rearing in captivity.

Temperature is known to modulate many biological and physiological processes, such as duration/extension of breeding, growth rate, clutch size, inter-clutch interval or feeding rate, among others (Foster and Vincent, 2004). Temperature effects on growth, survival or reproduction have been demonstrated in *H. abdominalis* (James and Woods, 2001; Martínez-Cárdenas and Purser, 2012), *H. whitei* (Wong and Benzie, 2003), *H. erectus* (Lin et al., 2010), *H. guttulatus* (Planas et al., 2012, 2013), *H. kuda* (Lin et al., 2006; Lin et al., 2007) and *H. trimaculatus* (Sheng et al., 2006). The wide temperature ranges at which seahorses can be found in the wild suggest developmental dependency on such environmental factor which might slow or enhance seahorse growth, and subsequently affect on juvenile survival.

On the other hand, light is strongly related to feeding ability in active visual predator fish. Morphologically, seahorse features (big eyes and lack of lateral line) suggest active ambush and visual feeding during the day, and the cessation of feeding activities at night, as shown in *H. kuda* (Sheng et al., 2006) and late juveniles of *H. abdominalis* (Ouyang, 2005). Natural and extended photoperiods in preliminary experiments have been widely applied to seahorse culture, ranging from a continuous light regime (24h light) in *H. kuda* (Pawar et al., 2011) to a shorter day-light regime (10h Light:14h Dark) in *H. hippocampus* (Otero-Ferrer et al., 2010). The effects of different photoperiod regimes on seahorse physiology, reproduction, growth or survival have been reported in some species (*H. abdominalis*: Martínez-Cárdenas and Purser, 2007, 2012; *H. barbouri*: Garcia et al., 2010; *H. capensis*: Lockyear et al., 1997; *H. guttultus*: Planas et al., 2010a, 2013; *H. reidi*: Olivotto et al., 2008; and, *H. trimaculatus*: Sheng et al., 2006). Although pre- and ongrowing of marine fish, including seahorses, are almost universally carried out under a day-night cycle; however, most marine fish larvae are reared under continuous light until certain ages. In seahorses, the effects of different light regimes on the early stages of development remain uncertain.

Diseases are a major concern in the breeding and maintenance of captive seahorses due to their vulnerability in laboratory and aquaculture confinement (Koldewey and Martin-Smith, 2010). Health problems have been related to *Vibrio* spp. (*H. guttulatus*: Balcázar et al., 2010, 2012; *H. kuda*: Alcaide et al., 2001; Tendencia, 2004; Raj et al., 2010; *H. reidi*: Martins et al., 2010), microsporidians (*H. erectus*: Blasiola, 1979; Vincent and Clifton-Hadley, 1989), ciliates (*H. abdominalis*: Di Cicco et al., 2013; *H. hippocampus*: Ofelio et al., 2013; *H. kuda*: Shin et al., 2011), and micobacteriosis (*H. guttulatus*: Balcázar et al., 2011). Additionally, other less frequent diseases have been also reported such as tumoral neoplasia in *H. kuda*

(LePage et al., 2012) and *H. erectus* (Willens et al., 2004) and nephrolithiasis in *H. reidi* (Lewisch et al., 2013).

Hippocampus guttulatus

Hippocampus guttulatus is a one of the two European seahorse species that, due to family discrepancies, has received four different specific names: *H. bicuspis*, *H. filamentosus*, *H. longirostris* and *H. ramulosus* (Fishbase, 2014) although *Hippocampus guttulatus* is the currently accepted name. In Europe, two seahorse species (*H. guttulatus* and *H. hippocampus*) have been described (Curtis and Vincent, 2006). Species identification based on the presence or absence of skin filaments has led to several morphological misidentifications between European species (Figure 1.10), which may also derivate in failure of biological, ecological and management data because of their relatively closed distribution pattern (Curtis and Vincent, 2006). To avoid such problematic, identifications are currently based on genetic studies (Pardo et al., 2007; López, 2010; 2011).



Figure 1.10. European seahorse species: *Hippocampus guttulatus* and *Hippocampus hippocampus*.

Adult *Hippocampus guttulatus* are generally yellowish, dark green, brown or even blackish, and covered by an individually white-dotted pattern (Curtis and Vincent, 2005, Planas 2008, pers. obs.). However, as all seahorse species, *H. guttulatus* may change coloration for camouflage depending on the surrounding habitat (Curtis, 2006b), during courtship displays (Planas et al., 2008b) or stressful conditions (pers. obs.). Therefore, skin coloration and skin filaments are unreliable for taxonomic identification (Curtis, 2006a).

Both European seahorse species, *Hippocampus guttulatus* and *H. hippocampus*, sympatrically occupy habitats throughout the Mediterranean Sea and north-eastern Atlantic

Ocean (Lourie et al., 1999; Curtis and Vincent, 2005). Their closely inhabiting proximity has been related to evolutionary differences, which allowed both species to exploit different niche's resources according to their patchy territorial distribution (Garrick-Maidment, 2004). The distribution of *Hippocampus guttulatus* (Figure 1.11) extends from British Isles to Morocco, Canary Islands, Madeira, Azores, and the Mediterranean, Aegean and Black Sea (Boisseau, 1967; Lythgoe and Lythgoe, 1971; Reina-Hervás, 1989; Curtis and Vincent, 2006; Keskin, 2010). The species has been recorded in Netherlands, England, France, Spain, Portugal, Senegal, Morocco, Italy, Malta, Croatia, Greece, Cyprus, Ireland and Turkey. The northern record available for the species is at the Shetland Isles. Additionally, it has been also described 37 miles inland at Dagenham in the Thames River (Garrick-Maidment, 2004, 2007, 2011; Garrick-Maidment et al., 2010).



Figure 1.11. Distribution of the European long-snouted seahorse *Hippocampus guttulatus* (Source: IUCN, 2013)

Studland (United Kingdom) and Ria Formosa Lagoon (Portugal) are internationally hotspots for wild seahorse populations (Curtis and Vincent, 2005; Garrick-Maidment, 2011) were both European seahorse species co-exist. The importance of the former location is related to the high breeding rates of *H. guttulatus*, which may be recruiting juveniles to surrounding sites and therefore maintain welfare of seahorse wild stocks. The later location has been described as a world oasis for seahorses with an estimated population in the subtidal area of the lagoon of about 2 million individuals during 2001-02 (Curtis and Vincent, 2005). Both regions are characterized by being shallow waters with presence of seagrass beds. Indeed, *Hippocampus guttulatus* mostly occurs in macroalgae and eel grass of shallow

inshore waters (Curtis and Vincent, 2005; Planas et al., 2008). Both vertical and horizontal migrations have been reported for *H. guttulatus* and their capability to move distances much larger than what it was though its home range has been confirmed, despite their tendency to stay within small overlapping home ranges (Curtis and Vincent, 2006; Garrick-Maidment et al., 2010; Caldwell and Vincent, 2012, 2013).

Wild *H. guttulatus* adults are usually found at depths above 12 m (Lourie and Vincent, 2004) but deeper records have been reported (down to 46 m in the UK) during wintertime when water temperatures are generally at their lowest (Garrick-Maidment, 2004). Migrations of *H. guttulatus* wild populations have been reported to be geographically dependent, occurring mainly in exposed areas where weather conditions (extreme tides or winter storms) may suppose a high risk of damage, whereas in more sheltered areas (e.g. harbors, estuaries and lagoons) seahorses are grouped into sedentary and settled populations (Garrick-Maidment, 2007).

The breeding season of the species is thought to be from March, when water temperature starts to be warmer and daylight is becoming larger, until November, when water temperature starts to decrease and lightening is shortening (Planas et al., 2013). Temperature and photoperiod variations have been also related to seasonal migrations into deeper/shallower areas (Garrick-Maidment et al., 2010). Additionally, migrations usually coincide with food availability for fry, which tend to be higher from September to November with several peaks mainly influenced by lunar cycles (Garrick-Maidment, 2011). *Hippocampus guttulatus* is a multiple spawner along a single reproductive season (Curtis, 2004; Planas et al., 2010a). In the wild, annual spawning frequency of females has been estimated to be approximately 5 clutches with a mean clutch size of 214 ± 111 eggs per breeding season (Curtis, 2007). Female gonad development and hatching is highly affected by temperature and inter-clutch interval becomes almost identical to the gestation duration in males, reaching therefore high female–male synchronization (Planas et al., 2010a). Eggs of *H. guttulatus* are particularly large and much bigger (0.9 to 2.0mm in diameter) than in many other seahorse species (Planas et al., 2010a). Pear shaped eggs of late maturing oocytes of female *H. guttulatus* contain yolk reserves accounting for about 60% of total egg volume. Its high weight per volume unit ($237\mu\text{g}/\mu\text{l}$) suggests that nutrients are highly concentrated and rich in protein and lipids (Álvarez et al., 2009; Planas et al., 2010a).

In the wild, female *H. guttulatus* play a passive role during courtship events (Faleiro et al., 2008). However, in captivity, females looking for males to court with have been frequently seen (Planas et al., 2008b). Faleiro et al. (2008) described male competition during simultaneous courtships, showing aggressive behaviours towards the competitors by snapping them with the snout, and grasping their tails (pers. obs.). Male pregnancy lasts for 21 - 30 days depending on the temperature level (Foster and Vincent, 2004; Planas et al., 2008b; Garrick-Maidment, 2011). However shorter pregnancy periods (approximately 15 days) have also been reported (Faleiro et al., 2008). The long internal brooding leads to relatively high survival rates of embryos, ensuring an almost complete release of all fry. In the wild, mean brood sizes (435 ± 116) released newborn measuring 12 - 16 mm (Curtis and Vincent, 2006; Planas et al., 2013). Immediately after leaving the male's brood pouch there is no further parental care and the newborn need to swim directly to the water surface to gulp air to develop the swim-bladder and start to feed (Curtis and Vincent, 2006; Garrick-Maidment, 2011; Planas et al., 2012, 2013; Palma et al., 2013). *Hippocampus guttulatus* juveniles have a planktonic period that allows the fry to disperse and settle on new cryptic niches to grow up avoiding predation (Garrick-Maidment, 2011; Caldwell, 2012). The preferred habitat for settlement is chosen according to density and type of seagrass/meadows, water currents, food availability, presence of other seahorses, etc. (Pérez-Ruzafa et al., 2004; Curtis and Vincent, 2006; Caldwell and Vincent, 2013). Maturation in the wild has been estimated to occur after six months of age, when wild seahorse juveniles reach approximately 109 mm (Curtis and Vincent, 2006).

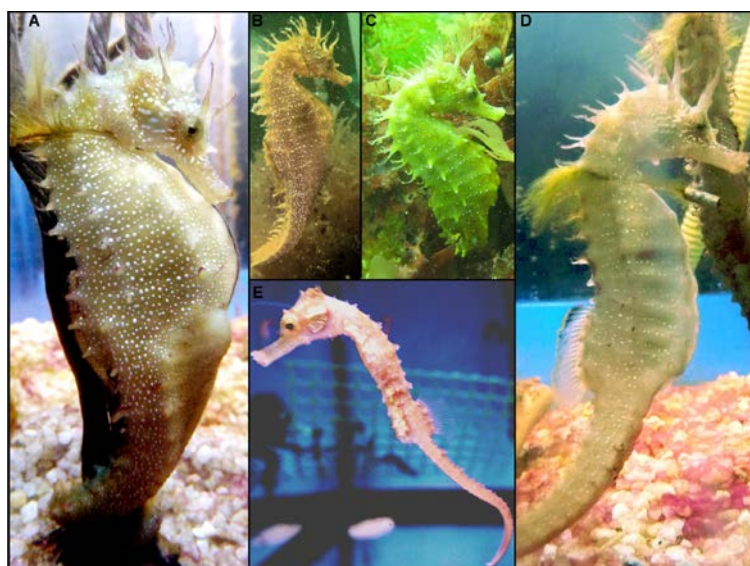

Figure 1.12. *Hippocampus guttulatus* in captivity (A, D, E) and in the wild (B and C). Male (A and B), Female (C and D) and immature juvenile (E).

Wild adults can reach up to 26 cm in standard length in Northwest Spain (Present Thesis). Adults are notable cryptic animals that blend into their habitat by modifications in both colouration and form, with the appearance of skin filaments that increase their resemblance to their habitat (Figure 1.12). Indeed, the crypsis capability of the whole members of the family Syngnathidae is highly evolved in order to avoid predation. Unfortunately, crypsis is not a perfect solution to avoid predation since environmental alterations or even biological behaviours may encompass high risk of exposure. The only predator reported for *H. guttulatus* is *Octopus vulgaris* in Ria Formosa (Portugal) (Kleiber et al., 2011, Caldwell and Vincent, 2012). Hence, population declines might be doubtfully due to natural predation but very likely to environmental disturbances and anthropological modifications. These main threats on wild populations might only naturally recover if the stressing factors are reduced or disappear.

Sedentary strategies in *Hippocampus guttulatus* are associated to habitat specialization and characteristics such as small home ranges, low mobility and sedentary lifestyle, suggesting an increasing population risk in a climate change scenario (Aurélio et al., 2013). In spite of its habitat selectivity, *H. guttulatus* is able to settle in a variety of niches mainly conditioned by depth and water current speeds (Caldwell and Vincent, 2013). Habitat disturbances have been related to seahorse population dispersion either involuntarily or voluntarily (Caldwell and Vincent, 2013). However, seahorses usually settle in individual preferred habitats that might not be ideal for all individuals of the population. Indeed, *H. guttulatus* appears to be more specialized in their environmental needs than other seahorses (Garrick-Maidment, 2011). Additionally, some social aggregation degree seems to play a key role on the election of a suitable habitat (Caldwell and Vincent, 2013).

In addition to IUCN and CITES international listing for conservation and welfare of *H. guttulatus* populations, this European long-snouted seahorse is listed as Near Threatened and Endangered in Croatia and Turkey (respectively), and as Vulnerable in Georgia and Ukraine. Moreover, in Bulgaria, France, Portugal and Slovenia this species is listed in their National Red Data Books. In the United Kingdom, it is protected by the Wildlife and Countryside Act of 2008 (DEFRA, 2008) and considered by the UK Biodiversity Action Plan as a priority species (JNCC, 2010). *H. guttulatus* is also included in OSPAR list of threatened habitats and species (OSPAR, Convention for the Protection of the Marine Environment of the North-East Atlantic).

In Spain, the species has been recently included in the Spanish List of Wild Species with Special Protection Regime and in the Spanish Catalogue of Endangered Species (BOE, 2011). Protection of wild populations and habitat conservation of seahorses are considered of interest in Spain. However, in Galicia (where the studies of the present Thesis were done), there are no regional regulations by the Consellería de Medio Ambiente Territorio e Infraestructuras (Ministry of Environment, Territory and Infrastructures) nor the Dirección Xeral de Conservación da Natureza (Directorate for Nature Conservation) to protect wild populations of the two seahorse species present in the region: *Hippocampus guttulatus* and *H. hippocampus*. Besides this, none of these species is listed in the Galician Catalogue of Endangered Species (CGEA).

The limited information available on the distribution, biology and rearing of *H. guttulatus*, as well as the lack of information to make a direct, or indirect, assessment of its risk of extinction based on its distribution and/or population status has supposed the change of their firstly 'Vulnerable' status in 1996 to a 'Data Deficient' status since 2003 (IUCN, 2014). In order to solve the uncertainty of the 'Data Deficient' status of any species, knowledge on their biology and ecology must be improved. Population studies carried out on wild *Hippocampus guttulatus* in Ria Formosa over a period of 7 to 8 years showed a sharp decline of over 90% of the estimated population (Caldwell and Vincent, 2012). According to IUCN category criteria and considering the worst possible scenario in which the causes of the reduction are clearly reversible, understood and ceased, a species might be considered Critically Endangered when population declines are higher than 90% for a period over ten years or three generations (whichever is the longer).

H. guttulatus captures have been occurring in most Mediterranean countries and Portugal either intentionally or incidentally, mainly for curios and aquariums. In Galicia, the potential threats in *H. guttulatus* are mainly habitat loss or degradation and by-catch. In this context, a captive breeding program (Proyecto Hippocampus) for *H. guttulatus* was initiated for the first time in Europe in 2006, at the Institute of Marine Research (CSIC) in NW Spain. The main objective of Proyecto Hippocampus was the recovery of wild *H. guttulatus* populations in Galicia based on a previous development of a feasible and reliable *ex-situ* breeding technique. In accordance with the IUCN Captive Breeding Policy, the breeding programme in Proyecto Hippocampus was in advance of a potential and irreversible fall of populations below a too low census size (IUCN). In this sense, it was important that the

breeders used in the husbandry and breeding programme were a high representative fraction of the genetic diversity of the source populations including genetic analyses for broodstock management to retain maximum genetic diversity and minimize inbreeding (Planas et al., 2010a). The studies carried out on wild population genetics showed moderate levels of genetic diversity, historical reductions in population size and a subsequent demographic expansion, which may aware of maintenance of genetic variability and a risk of short- and long-term adaptive potential for the species (López, 2011).

Prior to the studies undertaken in the present Thesis, studies of the European long snouted seahorse *H. guttulatus* were mainly focused on wild populations (Curtis, 2004, 2006b, 2007, Curtis and Vincent, 2005, 2006; Kitsos et al., 2008; Naud et al., 2009) and adult husbandry and captive breeding (Faleiro et al., 2008; Palma et al., 2008; Planas et al., 2008a, 2008b, 2009a, 2009b). However, studies on the rearing of *H. guttulatus* juveniles were limited.

Difficulties in the breeding success were initially related to nutritional deficiencies of diet when relied on *Artemia* solely (Planas et al., 2008b; Olivotto et al., 2011). However, captive seahorses showed no differences compared to wild seahorses in terms of female maturation, clutch size or, even, brood size (Curtis, 2007; Planas et al., 2009b). Conversely, Faleiro (2011), pointed important detrimental effects of captivity on the reproductive success and brooding quality of the fry. In this sense, advances on the establishment of adequate temperature and photoperiod conditions have improved breeding seasons and captive conditions by controlling successfully courtships and mating events (Planas et al., 2010a, 2013). Additionally, preliminary results showed that seahorses maintained in larger groups, would have growth enhancement compared to seahorses that must compete with others for a mate, as shown in Planas et al. (2008b). In that study, it was pointed that males in captivity do not always remain faithful to their pairs for courtships and mating events. However, the presence of females with hydrated eggs while male pregnancy has been related to the premature release of embryos and underdeveloped young in order to be prepared again for mating (Planas et al., 2009c). The isolation of pregnant males resulted in an improvement in the release of normally developed newborn and in their potential conditions to survive.

Unfortunately, at the commencement of the present Thesis no information was available on the most adequate rearing conditions for *Hippocampus guttulatus*. Several physico-chemical and biological factors need to be addressed to achieve acceptable growth

and survivals in early developing juveniles. Conversely to other seahorse species, *H. guttulatus* have an extended planktonic phase (Curtis, 2004). As seahorses are physoclistous fish that need to gulp air from to inflate the swim bladder, the access to water surface is essential. However, preliminary studies on juvenile rearing resulted in the lack of swim bladder or in presence of a high proportion of swim bladder dysfunctions (hyperinflation). Mass mortalities were achieved within the first two weeks and almost no juveniles survived beyond the first month of life. Therefore, it was essential to assess an optimal rearing aquaria design that provided evenness of the rearing conditions, allowing a homogeneous distribution of fish and preys in the water column. Surprisingly, there were no previous studies available testing different aquaria designs for seahorse rearing. However, Woods (2003c) improved the survival of newly released *H. abdominalis* by preventing juveniles from accessing to water surface. Additionally, aeration regime has been considered essential for an adequate distribution of young juveniles in the water column in other fish larvae (Sakakura et al., 2006). Although little is known on the effect of water turbulence and aeration intensity in the rearing system of juvenile seahorses, preliminary studies on *H. hippocampus* juveniles, pointed out that survival was strongly affected by the aeration intensity supplied (Molina et al., 2007). Aquaria designs and aeration intensities have been considered in detail in this Thesis (Chapter 1 and Chapter 4).

Among other environmental factors, photoperiod regime and temperature are pivotal factors in the rearing of many species. In the wild, the early development of seahorses coincides with summertime (from June to September). During that period, the photoperiod regime and seawater temperature are about 16L:8D and 19-20°C, respectively. Light regime is related to a wide variety of behaviours and biological rhythms in fish larvae (Fielder et al., 2002) but there is high discrepancy on the most adequate photoperiod for seahorse rearing. The impact of this factor in seahorses have been scarcely studied (Sheng et al., 2006; Olivotto et al., 2008; Martínez-Cárdenas and Purser, 2012) and, due to its species-specific effects, it was considered essential to determine the optimum photoperiod regime for rearing *H. guttulatus* juveniles (Chapter 1). Temperature affects the initial growth, ontogenetic development, and catabolism and, subsequently, the survival of fish larvae (Fuiman et al., 1998; Kamler, 2002). The range of temperature tolerance in *H. guttulatus* newborns and its implications on growth and survival were unknown until now, and are particularly studied in the present Thesis (Chapter 2).

Despite environmental factors, nutrition and feeding regimes have been widely studied in many seahorse species, and considered a bottleneck in early developmental stages of some seahorses (Olivotto et al., 2011). Feeding regimes in *H. guttulatus* juveniles were not conveniently studied, and some aspects such as prey type, quality, size, and quantity of prey supplied required to be properly addressed. Due to their initial size, preliminary observation on the use of rotifers as prey to feed *H. guttulatus* newborn was not considered ideal. The use of *Artemia* nauplii as unique prey was associated to an initial low rearing success ($\leq 25\%$) (Faleiro, 2011; Palma et al., 2011), probably due to the limited digestive capabilities of newborn (direct visual observation) over the nauplii (Olivotto et al., 2011). Results achieved in other seahorse species (and preliminary results on *H. guttulatus*) demonstrated that survival and growth were improved when introducing copepods in the diet. Therefore, the use of that prey alone or as part of a mixed diet was analyzed in this Thesis (Chapter 4) and compared to *Artemia*. Additionally, ontogenetic changes in the size of mouth and in the morphology/physiology of the digestive tract were also considered as factors that might affect at the rearing performance (Chapter 3 and Chapter 5).

Considering the very limited knowledge on the effects of zootechnical, physical and biological factors on the rearing of early developing *Hippocampus guttulatus* juveniles, the aim of the present Thesis was to establish a standardized and enhanced rearing procedure to ensure successful growth and survival rates in the early development (up to 1 month of life) of newborn. It is intended that the issues addressed in this Thesis and the resulting rearing methodology to be useful as a tool for the recovery of wild seahorse populations in further conservative plans and potentially applicable for the production of *H. guttulatus* for the aquarium trade (Chapter 6).

2. OBJECTIVES

The main objective of the present Thesis was to establish a reliable rearing methodology for the production in captivity of seahorse juveniles *Hippocampus guttulatus* with the aim of i) ensuring the future production of individuals for reinforcement or repopulation plans of wild stocks and ii) introducing the species in the aquarium trade.

The specific objectives of the present Thesis were related with the improvement of growth and survivals during early developmental stages by establishing the most appropriate rearing conditions in relation with the following topics:

A) Zootechnical and physical factors in the rearing system:

1. To select the most appropriate aquaria type to ensure an even distribution of juveniles and prey in the rearing media.

2. To determine the most adequate levels in aeration intensity, photoperiod regime and temperature in order to minimize swimbladder hyperinflation disorders and maximise survivals.

B) Feeding:

1. To assess prey preference in *Hippocampus guttulatus* juveniles fed on different preys (*Brachionus plicatillis*, *Artemia* sp., and *Acartia tonsa*).

2. To establish optimal prey sizes at different developmental stages.

3. To improve growth and survivals of juveniles by introducing copepods (*Acartia tonsa*) in the diet.

4. To optimize the feeding regime for juveniles.

5. To assess the effect of feeding regime on the digestive capabilities of developing juveniles.

6. To propose a standardized and optimized methodology for the successful rearing of *H. guttulatus*.

3. GENERAL MATERIALS AND METHODS

3. General Materials and Methods

The present section describes the routines and general conditions for maintenance of seahorses (breeding and rearing) as well as the techniques used and the general procedures for sampling and analysis performed. Detailed methodologies for the experiments undertaken in this Thesis are further explained in the corresponding chapters.

3.1. Seahorse Collection

From January 2010 until January 2014, a total of 57 wild-seahorse *Hippocampus guttulatus* were collected from the following locations in the Galician coast (Northwest Spain): Ribeira Harbour, Arousa Island, Aldán, Bueu, Toralla Island, Sada and A Guía (Figure 3.1). In order to minimize the impact of wild captures while ensuring enough genetic pool, a maximum of 10 seahorses were removed from their habitat, except at Bueu ($n = 20$) where a higher number of seahorses were recorded. Wild pregnant males sampled accounted for less than 25% of total seahorses recorded at each locality, with the exception of Ribeira Harbour, in which the two unique captured seahorses were pregnant.



Figure 3.1. Sample sites from Galician coast (NW Spain). A) Sada Harbour; B) Arousa Island; C) Ribeira Harbour; D) Bueu; E) Aldán; F) A Guía; and, G) Toralla Island

Seahorses were hand-caught by scuba diving at an average depth of 4.4 m; the maximum and minimum depths recorded were 9.5 m and 1.4 m, respectively. Approximately

50% of the captured seahorses were found associated to seaweeds and seagrass habitats (Bueu, Toralla, Aldán and Arousa Island localities). Ribeira and Sada Harbours were mainly dominated by muddy habitats. Recorded seahorses were usually holdfasted to macroalgae or mooring chains, and rarely found actively swimming.

All captured seahorses were sexed, photographed (for standard length measurements) and wet weighted. The pregnancy status of males was also recorded. Overall, 27 females (196 ± 22 mm and 16 ± 4 mg) and 30 males (194 ± 26 mm and 18 ± 5 mg) were captured and subsequently individually placed into 20 L plastic bags containing 1/3 seawater and 2/3 air and transported to our facilities in isothermal polystyrene boxes. On arrival, each seahorse was tagged with a unique alphanumeric code using VIFE and collar tags, and skin filaments were sampled for genetics (Planas et al., 2008b; López et al., 2010; López, 2011). Then, seahorses were progressively acclimatized to captive conditions. Wild-pregnant seahorses were directly isolated in separated aquaria and sampled after newborn release.

Most seahorses remained in captivity for an average period of 617 days. However, some pregnant seahorses were released to their origin in the wild after newborn release (about one week after capture) while others remained in captivity for over three years. The maximum time spent by a wild seahorse in our facilities was 1220 days.

Overall, 68% of the captured seahorses were released back at their original sampling locations, 18% died ($n = 10$) and 14% still remained at IIM facilities. Only 2 seahorses died before 3 months (20 and 82 days) since being captured. Although visual examination and necropsies did not show signs of illness in most cases, tail rot and skin ulcerations were observed in some fish.

3.2. Broodstock captive conditions

Seahorses were acclimatized to captive conditions by the gradual addition of seawater from the husbandry aquaria into the holding bag for a period of 3 - 5 hours. No therapeutic treatments or quarantine were applied. Seahorses were then transferred to husbandry aquarium units (320 L volume) (Figure 3.2), which consisted of three subunits of 160 L each (85 height \times 75 length \times 50 wide cm). Two subunits were separated by a removable opaque blue methacrylate panel (Planas et al., 2008b). The frontal walls of the aquaria were transparent while the other walls and the bottom were opaque blue. For seahorse holdfast,

polyethylene grey nautical ropes ($\varnothing = 16\text{mm}$ and 25-40 cm length) un-plaited into four 7 mm thick ropes, and green Corkscrew Vallisneria like plastic plants (30 cm tall) were used. All holdfasts were Epoxy-glued to a small stone. In 2011, the bottom of the aquaria was covered by an under gravel filter (2-5 cm).

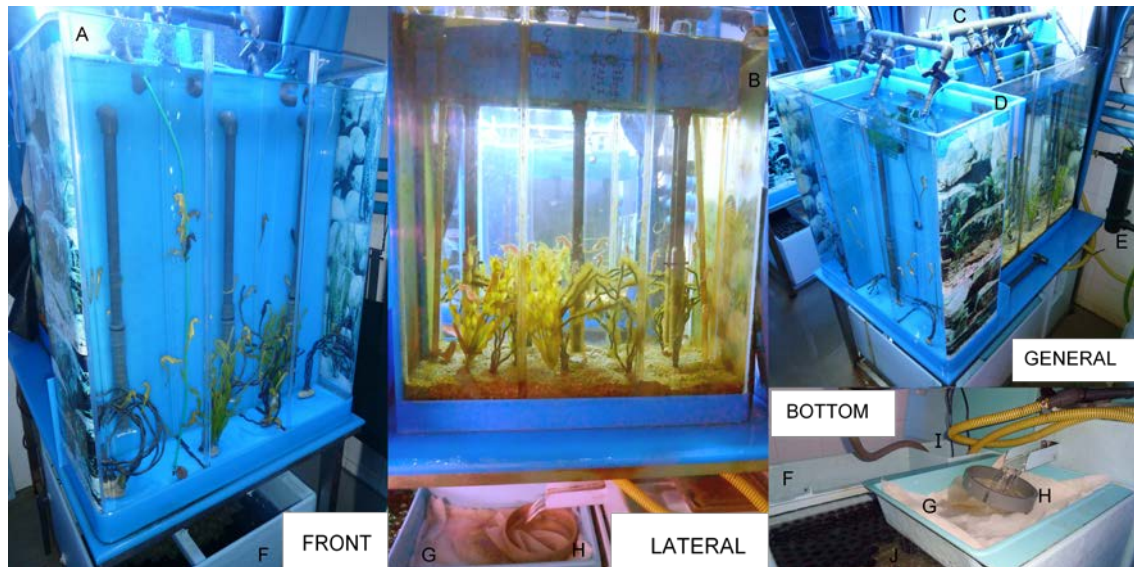

Figure 3.2. Broodstock aquaria used in the maintenance of seahorse (*Hippocampus guttulatus*) A) Frontal sub-unit (160 L); B) Main sub-unit (320 L); C) water inlet system; D) Water outlet; E) UV-light treatment; F) Water reservoir (50L). Bottom show the filtration system and pumps: G) Filter wool; H) 100 μm mesh; I) Pump; J) Biofilter.

During the first two years (2009 and 2010), prior to the installation of the under-gravel filter, an inlet PVC pipe located at the water surface of each sub-unit was connected to a mobile PVC elbow for adjustment of the direction and depth of the water jet in the aquaria while avoiding the entry of air bubbles. Since 2011, the water inlet was located below the under-gravel filter and the water was pumped bottom-up.

A screened-meshed window was located 2 cm above the water surface to prevent accidental overflow while avoiding seahorses to pass through. The water overflow was drained through a PVC pipe located 10-20 cm above the bottom of the aquaria, collected into an outlet box and drained down towards the seawater treatment system. Aeration was provided by two pipe lines. In each subunit of the aquarium, a 20w fluorescent tube (4000 K) located 25 cm above the water surface provided a light intensity of about 850–1050lx.

The seawater was treated mechanically, chemically and biologically by means of a Venturi pump, a skimmer, a mechanical filter (100 μm mesh and filter wool) and finally a biofilter, which consisted of perforated plastic balls and a bed of coral sand and charcoal. Two

pumps (PASQ B-30 and PASQ B-A26) distributed, in a flow-through system ($5\text{--}6\text{ L min}^{-1}$), the water into the 320 L and 160 L subunits, respectively.

Photoperiods simulating those in the seahorses' natural environment were applied and weekly adjusted manually by a timer. The photoperiod cycle ranged from 16L:8D (June–July) to 10L:14D (December–January). Additionally, in 2012, one aquarium was submitted to a drastic photoperiod shifting (Figure 3.3) to allow mating events all year round (Planas et al., 2013). During the dark phase of the day, the aquaria were covered with black tarpaulin curtains. Temperature levels were gradually adjusted (max. 1°C every 2–3 weeks) following a natural-like cycle ranging from 15°C in wintertime (January–February) to 20°C in summertime (July– August). For the drastic photoperiod shifting, temperature levels were adjusted accordingly as reported by Planas et al. (2013).

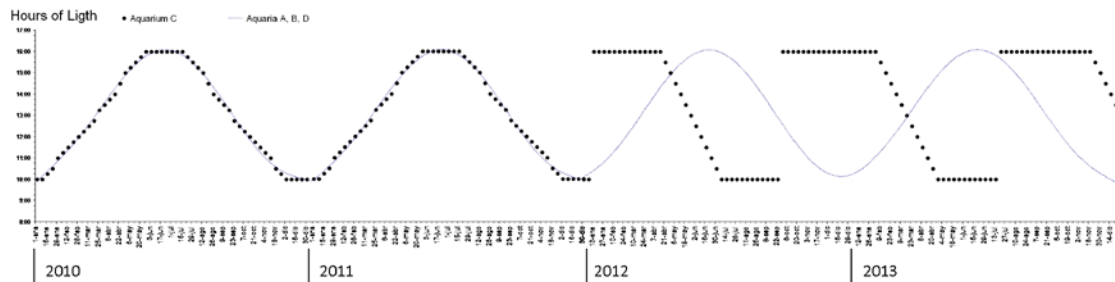

Figure 3.3. Photoperiod regime applied in the broodstock aquaria (160 L) in a continued cycle (blue line) and in a drastic shifted cycle (black dotted line).

Wastes and uneaten food were removed daily by siphoning the bottom of the aquaria early in the morning. During aquaria cleaning, about 10–15% of the total water was discarded and subsequently replaced with filtered ($5\mu\text{m}$) and UV-light treated seawater. Water quality was checked periodically for NO_2 , NO_3 and NH_4/NH_3 content (0 mg L^{-1}) by using Sera Test Kits. Salinity and pH levels were $37 \pm 2\text{ppt}$ and 8.0 ± 0.2 , respectively.

The diet of adult seahorses consisted on a mixture of adult enriched *Artemia* (EG, AF, MC450; Iberfrost, Spain) and wild-captured Mysidacea (*Leptomysis* sp. and *Siriella* sp.) or cultivated shrimp *Palaemonetes varians* (Chamorro et al., 2010). Adult *Artemia* was grown out for over 12 days on a mixture of microalgae (*Phaeodactylum tricornutum* and *Isochrysis galbana*), 0.015g l^{-1} of Red Pepper (Bernaqua, Belgium) and 0.03g l^{-1} of Spirulina (Iberfrost, Spain). Extra doses of Red Pepper (0.08g l^{-1}) were supplied for at least 3 days prior to *Artemia* harvesting. During wintertime, adult seahorses were fed twice daily on adult *Artemia* ($40\text{--}70\text{ Artemia seahorse}^{-1}\text{ dose}^{-1}$) for at least 5 days a week and on a single dose of either Mysidacea ($15\text{--}20\text{ Leptomysis sp. and/or Siriella sp. seahorse}^{-1}$) or adult shrimps ($15\text{--}20\text{ P.}$

varians seahorse⁻¹) for 2 days a week, when available. In summertime, the diet consisted of two doses of adult *Artemia* (40-70 *Artemia* seahorse⁻¹ dose⁻¹) for 2 days a week and a single dose of either Mysids or Shrimps (20-30 prey seahorse⁻¹) at least 5 days a week.

Courtship displays and mating occurred during the most part of the breeding period in agreement with the photoperiod and temperature regimes applied. Up to 19 unfertilized egg lots (mean 278 eggs lot⁻¹, ranging from 98 to 547) were collected from the bottom of the tanks within the firsts 12 hours after release. Egg lots were subsequently counted, videoed for measurement purposes (major axis: 3.0 mm, minor axis: 1.5mm), rinsed with tap water and stored at -80°C for further analysis. A total of 72 newborn batches were used from 2010-2014. Fifty nine were released from captive mating at IIM-CSIC facilities and thirteen were released by males which were already pregnant when collected in the wild.

3.3. Rearing of juveniles

Pregnant seahorses were transferred from broodstock aquaria to 30L pseudoKreisel aquaria (18 °C and 16L:8D photoperiod regime) and maintained isolated for a few days until newborn release. However, 19 batches were released in the husbandry aquaria due to problems related to space limitations, miscounting of the pregnancy days or unnoticeable pouch engrossment. Within the first 12h after male's release, total batch size was recorded and healthy live juveniles were transferred to the experimental rearing aquaria. A total number of 23,425 healthy and live newborn were released at our facilities since the beginning of the present Thesis.

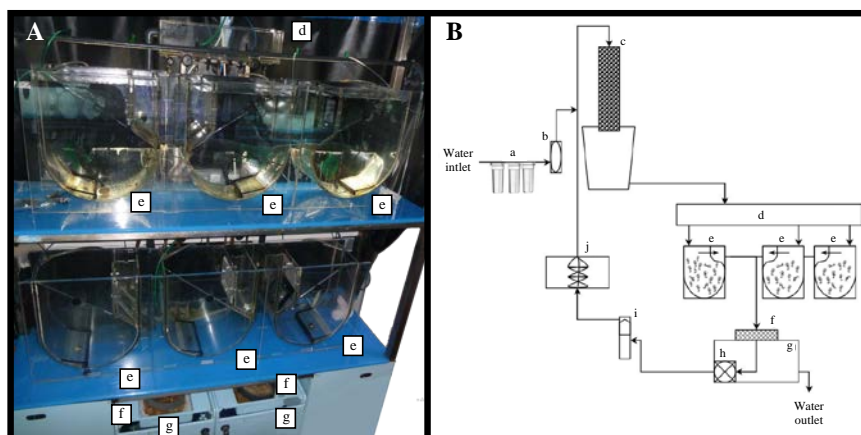

Figure 3.4. *Hippocampus guttulatus* juvenile experimental rearing system (A) and drawing representation (B): a) Mechanical filters (20µm, 5µm and 1µm), b) UV unit, c) Degasifying column, d) Water reservoir, e) Aquaria, f) Mechanical filter (30µm), g) Biofilter reservoir aquaria, h) Water pump, i) Skimmer, and j) Pump.

Newborn were transferred to their experimental aquaria at an initial average density of 4 juveniles L⁻¹. The rearing aquaria operated in a semi-opened recirculation system (Figure 3.4). All rearing aquaria were supplied with pre-filtered (20µm) seawater pumped directly from the Atlantic Ocean. Seawater was further filtered by a series of filter-cartridges (20, 10, 5 and 1µm) and UV treated (76w; 16 L min⁻¹) (JR1/50). The rearing system of juveniles included a degasifying column and two 50 L biofilters with mechanical (up to 20µm) and biological filters, aerators and skimmers. From the biofilter units, the seawater was pumped to secondary UV units (36w) and then to a 50 L reservoir aquarium, being finally routed by gravity towards the rearing aquaria.

Most rearing experiments were carried out in pseudoKreisel aquaria (Figure 3.5), made on polyurethane and designed at our facilities as a modification of a common Kreisel aquarium. This type of aquarium was designed following a combined circular (Upper part) and rectangular (lower part) shape. The water inlet (700 ml min⁻¹) was located at the surface level in one of the corners of the aquarium. The water outlet was placed at the opposite side of the aquaria and consisted of an outflow box subdivided into two smaller compartments. The first one determined the upper level of the water column and, since there the seawater was collected in a second compartment from where the water was discarded. The first compartment was screened (90 x 120 mm) towards the main compartment of the pseudoKreisel vessel. A 500µm mesh was used during light-time and substituted by a 250 µm mesh during night-time. Aeration was provided by a stand-pipe placed below the outflow. Additionally, two other aquaria types (spherical and rectangular shape) were also tested. They are fully described in the corresponding chapter Chapter 1 (see also ANNEX II).

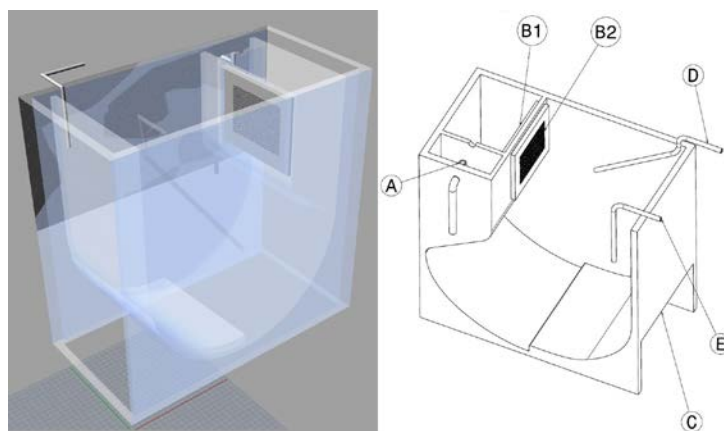

Figure 3.5. Aquaria used in the rearing of seahorse juveniles (pseudoKreisel design). Left: 3D drawing, Right: Detailed drawing. A) Water outlet; B) Screened mesh (B1: 500 µm and B2: 250 µm); C) Aquarium wall; D) Air pipe; and, E) Water inlet. See also Annex II.

Aquaria lighting was supplied by 20 w fluorescent lamps (Power Glo) during light-time and a 16L:8D photoperiod regime was commonly applied. The relative position of the lamps varied among the type of aquaria used. The half upper side of the walls in pseudoKreisel aquaria were always covered by black plastic films.

The water temperature for the rearing of seahorse juveniles *H. guttulatus* under captive conditions was settled at $19 \pm 1^\circ\text{C}$.

As a routine, the rearing of juveniles from male's pouch release (0 DAR – Days After Release) until 10 DAR was carried out on the following three diets:

- Diet A: four daily doses (09.00, 12.00, 15.00, 18.00) of *Artemia* nauplii (1 nauplii ml^{-1}).
- Diet M: a single dose of *Artemia* nauplii (1 nauplii ml^{-1}) at 09.00 and a single dose of *Acartia tonsa* (adult and copepodite, 0.6 copepod ml^{-1}) at 15.00.
- Diet C: from 0 to 5 DAR, a single dose of adult and copepodite stages of *A. tonsa* (0.7 copepods ml^{-1}) at 09.00; and, from 6 to 10 DAR, of a single dose of *Artemia* nauplii (1 nauplii ml^{-1}) at 09.00 and a single dose of *A. tonsa* (0.6 copepod ml^{-1}) at 15.00.

Afterwards, from 11 to 30 DAR, the juveniles were fed on 3–4 daily doses of *Artemia* nauplii and enriched metanauplii (1:1) at a total prey density of 1 *Artemia* ml^{-1} . Juveniles older than 30 DAR were fed *ad libitum* on a mixture of 24 and 48h enriched *Artemia* metanauplii (1:1) for, at least, 15 days. Afterwards, seahorses were grown on a mixture of *Artemia* metanauplii of different ages (in accordance to seahorse size) supplemented with adult calanoid copepods (*A. tonsa*), when available. From the age of 3 months, additional wild-caught mysidaceans (*Leptomysis* sp. and *Siriella* sp.) were supplied after stunning with tap-water. Live mysids were offered to juveniles from the age of 4 months. Since then, the juveniles were progressively and successfully weaned on frozen prey: wild-caught *Leptomysis* sp. and *Siriella* sp. and commercial mysids (*Neomysis vulgaris*) and krill (*Euphausia pacifica*) (3F-Frozen Fish Food).

3.4. Production of live food.

3.4.1. Microalgae

The following species of microalgae were used for both prey feeding and enrichment of *Artemia* metanauplii, rotifers and calanoid copepods: the coccolithophyceae *Isochrysis*

galbana Parke 1949, the diatom *Phaeodactylum tricornutum* Bohlin 1897, and the cryptophyte *Rhodomonas lens* Pascher and Ruttner 1913. The maintenance of microalgae strains under sterilized conditions were carried out in 250 ml Erlenmeyer flasks containing 100 ml of 0.22 μm filtered and autoclaved (Sartorius 11407-047-ACN) seawater supplemented with 200 μl F2P (100 g L⁻¹) media (VarAqua). For *P. tricornutum* cultures, 200 μl of silicates (40 g L⁻¹) were also added. *Rhodomonas lens* cultures were supplied with an extra dose of 200 μl F2P media (100 g L⁻¹) after 4 days. Culture flasks were maintained in a 22 ± 1 °C chamber under a continuous day-like white fluorescent light cycle. No aeration was supplied and manual mixing was applied to avoid cell sedimentation. After one week of culture, the microalgae reached their stationary growth-stage with approximately 10⁷ cells ml⁻¹ for *P. tricornutum*, 6x10⁶ cells ml⁻¹ for *I. galbana* and 4x10⁶ cells ml⁻¹ for *R. lens*. Then, 5 ml of the culture were used to inoculate new Erlenmeyer flasks whereas the remaining volume was inoculated in 5 L glass flasks. Subsequently, one 5 L flask was used to inoculate 80 L plastic bags when the microalgae cell density had reached the stationary growth-phase.

In the culture of 5 L flasks, the seawater was filtered (1 μm) and autoclaved for sterilization. Seawater was supplemented with 2ml L⁻¹ of F2P media (100 g L⁻¹), which was further re-added after 4 days in *R. lens* cultures. *P. tricornutum* were supplemented with 2ml L⁻¹ of silicates (40 g L⁻¹). The cultures were maintained at 22 ± 1 °C into an acclimatised room. Strong bubbling was supplied through a sterilized stand pipe. Continuous lightening was applied with day-like fluorescent lights. Exceptionally, seawater of 80 L plastic bags was not autoclaved and sterilization was carried out by bleaching (0.5 ml L⁻¹) for 2h and, then, neutralized with sodium thiosulfate pentahydrated (0.5 ml L⁻¹) (Merck). Neutralization was checked after 30 minutes with orthotolidine (Panreac).

3.4.2. Rotifer, *Brachionus plicatillis*

Monoxenic cultures of rotifers were maintained in 30 ml glass tubes (25 ml of useful volume). Pure and sterilized cultures were weekly reactivated by siphoning the bottom of the tube and discarding up to 75% of the total volume (approximately 20 ml), which was replaced with culture of *I. galbana* (6x10⁶ cells ml⁻¹). Rotifers were maintained in a chamber at 22 ± 1 °C and with continuous day-like fluorescent lightening. No aeration was supplied.

Rotifer (Figure 3.6 C) production for feeding experiments was carried out at 23°C in 20 L inverted pyramidal truncated tanks. Siphoning of detritus and debris was daily done by a renewal of 20% total volume, which was replaced with 2 L of microalgae *I. galbana* (6x10⁶

cells ml⁻¹) and 2 L of filtered (1 µm) seawater. Weak aeration was supplied by an air-stone. Two times a month, rotifer production was re-started.

3.4.3. Brine Shrimp, *Artemia* sp.

Artemia cysts were incubated at 28 °C for 20h in 15 L incubators. The cyst decapsulation was carried out by the addition of bleach (10ml L⁻¹) for 30 min and further neutralization with sodium thiosulfate (10ml L⁻¹). Chlorine free water was checked with orthotolidine. Newly hatched nauplii (Figure 3.6 D) were rinsed with tap-water for 30 minutes prior to be transferred to 5 L seawater buckets (100 *Artemia* ml⁻¹) with gentle aeration. *Artemia* metanauplii (Figure 3.6 E) were grown up to different ages in 5L buckets at 26 °C on different enrichment diets. *Artemia* metanauplii were filtered through a 125µm mesh and rinsed with tap water for 30 minutes prior to be enriched and distributed for seahorse feeding.

Live microalgae and commercial products were used for *Artemia* enrichment. Usually, the production of 24h enriched metanauplii was made on a mixture of *Isochysis galbana* (10⁷ cells ml⁻¹) and *Phaeodactylum tricornutum* (1.6 10⁷ cells ml⁻¹), Red Pepper (0.3g L⁻¹) and dried Spirulina (0.8g L⁻¹).

Different commercial enrichments were used: Red Pepper (BernAqua), dried Spirulina (Koralfarm), Ori-Go (Skretting) Algamac 3050, Algamac protein plus, Economac, and Proteomac (Aquafauna Bio-Marine, Inc), and Prolon and Culture Selco (INVE)

3.4.4. Calanoid copepods, *Acartia tonsa*

Copepod cultures were initiated at the facilities of the Italian National Institute for Environmental Protection and Research (ISPRA), Livorno, Italy. Adult *Acartia tonsa* were firstly cultured in Elisa plates (5 ml) containing 0.45 µm filtered and sterilized seawater (30 ppm). Copepods were fed on *Rhinomonas* sp (2.4x10⁴ cells ml⁻¹) and *I. galbana* (1.6x10⁴ cells ml⁻¹). The photoperiod applied was 13L:11D. Copepod nauplii were counted daily and transferred to 500 ml beakers for on-growing under the same conditions. Subsequently, adult copepods (500♀ + 200♂; Figure 3.6 A and B, respectively) were transferred to 1 L beakers. Identical feeding and lightening regimes were applied to all culture stages. Minimal aeration was supplied in all cases.

Copepod cultures of 1.5 L were transported in plastic bottles (0.5 copepods ml⁻¹) from ISPRA to IIM-CSIC facilities in Vigo, Spain. At IIM-CSIC, the production was initiated from a total copepod population of 1,000 individuals in 250 and 500 L tanks at low densities (up to

1 adult copepod ml⁻¹). The copepods were daily fed on a 10 L mixture (1:1 volume) of the microalgae *I. galbana* (10⁷ cells ml⁻¹) and *R. lens* (16⁷ cells ml⁻¹). Siphoning and water exchange (20% of the total volume) was done every other day. Each tank was partially harvested when necessary for seahorse feeding. For that, the copepods were concentrated after filtration through 180µm mesh, washed and counted. Once a month, the tanks were completely siphoned, bleached, rinsed and refilled with filtered seawater and microalgae and the copepod culture was reinitiated.

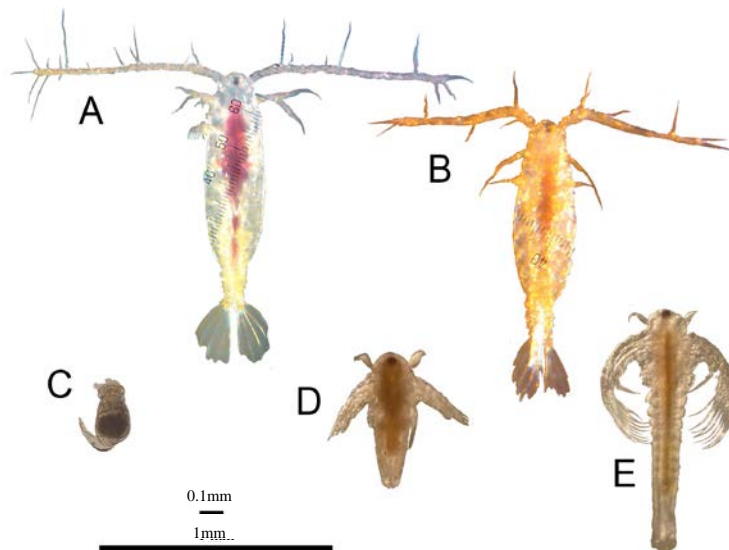

Figure 3.6. Live preys used in the feeding of seahorse *Hippocampus guttulatus* juveniles. A) Adult Female *Acartia tonsa*; B) Adult Male *A. tonsa*; C) Rotifer *Brachionus plicatilis*; D) *Artemia* nauplii; E) *Artemia* metanauplii.

3.5. Juvenile sampling

Seahorse batches were counted at day 0, after male's pouch release (0 DAR) and transferred to the rearing aquaria using a 250 ml beaker. Damaging of newborns by siphoning and exposition to air were avoided. At the end of each experiment, seahorse survivors were counted and the final survivals estimated after applying a correction for sampling mortality.

Newborn samples (n=20–30) were taken from all batches. Additionally 15 DAR (n=10–15) and 30 DAR (n=5–10) juveniles were also sampled when available. Sampled seahorses were anaesthetised with tricaine methanesulfonate (MS-222; 0.1 g L⁻¹), washed with tap water, transferred individually to Petri dishes and photographed for standard length (SL) measurements. Then, the excess of water was removed and each seahorse was individually weighted on a Sartorius microbalance MC210P (± 0.01 mg). An extra dose of MS-222 was additionally supplied to euthanate juveniles for different experimental

purposes. When necessary, samples were frozen, lyophilized (if required) and maintained at -80°C.

Dead or premature juveniles released were used for parental genetic identification; otherwise, 10 newborns were sacrificed (López, 2011). Seahorses that were not used for other purposes were awoken and transferred to their original aquaria.

SL was calculated as curved measurement of head + trunk+ tail length (Figure 3.7), as reported by Lourie et al. (1999). Measurements were made on digital images using an image processing software (NIS Elements, Nikon). Calculations involving development and growth were performed according to the formulations described in Planas et al. (2012) and explained in the corresponding chapters.

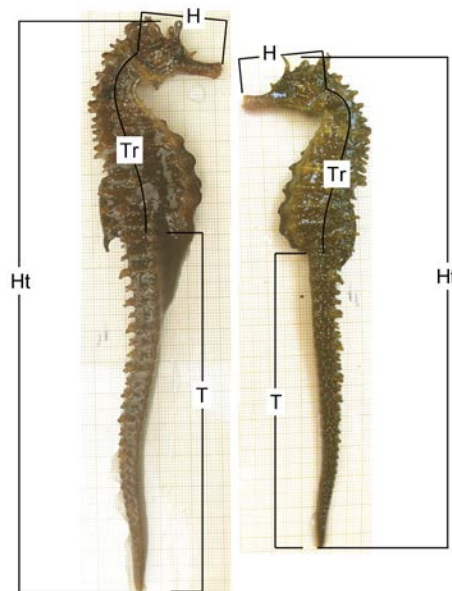

Figure 3.7. Standard Length S-measurements in male (left) and female (right) seahorse *H. guttulatus*. Ht: Total height; T: Tail length; Tr: Trunk length; H: Head length.

3.6. Proximal biochemical composition

Total lipid, total protein, soluble carbohydrates and ash content in prey, seahorse eggs and seahorse starving juveniles were analysed for proximate biochemical composition (Chapter 4 and ANEX III, ANNEX IV and V). All analyses were run by triplicate.

3.6.1. Total Lipid content

Total lipids determination was carried out following a modification of the methodology described by Bligh and Dyer (1959) and Fernández-Reiriz et al. (1989). Ten milligrams of biomass (DW) were used and extracted in methanol:dichloromethane (2:1),

sonicated (Banelin Senopuls GM-70) for 1 minute. Then, a second extraction was done with the addition of dichloromethane:MiliQ-water (1:1) prior to a second sonication (1 minute). Samples were centrifuged (3000 rpm) for 10 minutes at 4 °C. Lipid content was determined gravimetrically after evaporation of sub-samples (150 µl) in previously weighted aluminium cup.

3.6.2. Total Protein content

Total protein content in sonicated sample homogenates (1 mg ml⁻¹) were measured by the method of Lowry et al. (1951), samples were hydrolyzed with 0.5 N NaOH for 24h at 30 °C and then read at 750 nm with a spectrophotometer (Shimadzu UV-1800). Bovine Serum Albumin (Sigma) was used as standard.

3.6.3. Soluble Carbohydrate content

Soluble carbohydrates were analysed from sonicated sample homogenates (1 mg ml⁻¹) following the phenol–sulfuric acid method (Dubois et al., 1956). Glucose (Sigma) was used as reference.

Glycogen, when analysed, was determined following the same methodology. Previously, sonicated homogenates were centrifuged (4800 rpm) for 20 minutes at 6 °C with ethanol 100% (1:2). Then, carbohydrates/glycogen samples were read at 490 nm with a spectrophotometer (Shimadzu UV-1800).

3.6.4. Ash content

Ash content was determined following the methodology described by Mortensen et al. (1988). Ten milligrams (DW) of sample were heated at 550 °C for 24 h and the ash content gravimetrically obtained.

CHAPTER 1

**Implications of physical key factors in the early rearing of the
long-snouted seahorse *Hippocampus guttulatus***

Implications of physical key factors in the early rearing of the long-snouted seahorse *Hippocampus guttulatus*

ABSTRACT:

Seahorse rearing is a potential tool to reduce trade pressure on wild populations and also to diminish natural population declines. Although breeding conditions are rather well established for some seahorse species (*Hippocampus* spp.), only few studies are available on the rearing of *Hippocampus guttulatus* juveniles. Zootechnics and the effect of non-biological factors are still unknown for that European seahorse species. The present study is focussed on the effects of aquarium type/design, photoperiod regime and aeration level on the early performance (growth and survival) of *H. guttulatus* juveniles. Three aquarium types were evaluated: PseudoKreisel, spherical and rectangular. Juveniles grown in pseudoKreisel aquaria showed lower growth rates but significantly higher survivals ($69 \pm 15\%$) at day 30 after male's pouch release when compared to either spherical ($30 \pm 22\%$) or rectangular ($16 \pm 12\%$) aquaria. Survival enhancement in pseudoKreisel aquaria was mainly related to the very low proportion of juveniles showing swim bladder hyperinflation during the first days of life. In the other aquarium types, both aeration and water inlet did not impede juveniles to remain near water surface and to gulp air in excess for swim bladder inflation. The effects of light regime and aeration level were assayed in *H. guttulatus* juveniles reared in all three aquarium types or in pseudoKreisel aquaria only, respectively. In general, the application of extended (continuous light) or natural photoperiods (day-night cycle; 16h Light: 8h Dark) did not affect significantly survivals nor growth. On the other hand, aeration levels in pseudoKreisel aquaria significantly affected juvenile survivals. Survivals in 30 days old seahorses reared under a strong aeration were significantly higher ($41 \pm 12\%$) than when reared under weak aeration ($13 \pm 0\%$). Strong aeration levels enhanced the distribution of juveniles in the aquaria and diminished both their over-exposition to water surface and the resulting appearance of hyperinflation problems. The overall results suggest that the best rearing conditions were met when *H. guttulatus* juveniles grew in pseudoKreisel aquaria under both strong aeration level and, to a lesser extent, natural photoperiod regime.

1. 1. Introduction

Wild populations of seahorses (*Hippocampus* sp.) have been declining in the last two decades (Vincent, 1996) due to Traditional Chinese Medicine, curious and degradation of natural environment. Consequently, measures were undertaken to protect the Genus and to regulate seahorse exploitation and trade. IUCN red list included a seahorse species (Knysia seahorse, *H. capensis*) for the first time in 1988. The other species of the Genus were included in the following years (IUCN, 2013) concurrently with their inclusion in Appendix II of The Convention on International Trade in Endangered Species of Wild Fauna and Flora (CITES, 2002). The rearing of seahorses in captivity becomes a palliative activity to reduce the pressure on wild populations (Olivier, 2008) and the rising market demand (Koldewey and Martin-Smith, 2010; Olivotto et al., 2011). Seahorse culture started in late 80's with relative success in some Asiatic countries such as Australia, China, Japan or Vietnam (Vincent, 1996; Koldewey and Martin-Smith, 2010). In late 90's, when concern on the overexploitation of wild seahorses increased, significant enhancements were achieved in the production of *Hippocampus barbouri*, *H. fuscus*, *H. kuda* (Wilson and Vincent, 2000), *H. abdominalis* (Woods, 2000a) and *H. subelongatus* (Payne and Rippingale, 2000). Currently, rearing techniques are available for several species though the optimal rearing conditions have not been met in most species.

The fulfilment of fish needs requires the understanding of biological and physiological constraints that young fish might face in the rearing system. Compared to other marine fish, seahorses differ largely in their biology and, consequently, in their optimal rearing conditions (Olivotto et al., 2011). In addition, not all seahorse species perform similarly under rearing conditions, which implies that the rearing requirements must be investigated explicitly for each species. Improvements have been made recently in the cultivation of the European long-snouted seahorse *Hippocampus guttulatus*, especially on breeding (Planas et al., 2008b, 2009b, 2010a, 2013) and some important aspects of the early rearing of juveniles such as feeding/nutritional requirements (Olivotto et al., 2011, Blanco, unpublished data), fatty acid requirements (Faleiro and Narciso, 2010), optimal temperature level (Planas et al., 2012), holdfast preferences (Correia et al., 2013) and genetic inbreeding (López, 2011). However, others are almost unknown, namely those concerning physical factors.

The early rearing of seahorse juveniles is generally carried out in special aquaria rather than in conventional rearing units. To fulfil one of the main challenges for sustainable

aquaculture, the aquaria design should consider that the fish must be kept under the best conditions for growth and welfare with minimum resource consumption (Duarte et al., 2011). In addition, the engineering and design of the rearing systems should solve biological constraints of fish larvae (Nash et al., 1977). To achieve that, it becomes essential to use aquarium designs providing evenness of the rearing conditions, allowing a homogeneous distribution of fish in the water column (Ross et al., 1995) and ensuring a successful rearing. Studies on the early rearing of *H. guttulatus* pointed out a high percentage of juveniles showing swim bladder hyperinflation (Olivotto et al., 2011), which resulted in extremely low survivals during the first two weeks of development. Most hyperinflations commonly occur during the first week, impeding juveniles to feed normally. Apart of other possible causes (e.g. newborn quality), we strongly suspected that some zootechnical, environmental and physical conditions might be related to hyperinflation problems and that they could be addressed with an adequate assessment of the factors involved in the problematic. Accordingly, aquaria design, photoperiod regime and aeration level were the selected factors based on prior observations.

Aquaria design and water movement/turbulence affect water flow pattern in the aquaria, which may result in the presence of dead volumes and stagnant water zones that may compromise fish wellness (Duarte et al., 2011). In small volume aquaria, water inlets would have influence only on the region nearest of its placement in the aquaria. This makes water aeration essential for an adequate distribution of young juveniles in the water column (Sakakura et al., 2006). In this regards, aeration can be easily manipulated, preventing fish accessing to water surface and potentially providing immediate solution to fish mass mortality (Fui et al., 2012). On the other hand, it has been reported that high turbulences have negative impact on marine fish larvae due to physical contact and injuries by air bubbles. Additionally, turbulences might difficult feeding and would increase unnecessary waste of energy for hunting (Utne-Palm and Stiansen, 2002; Oshima et al., 2009; Sakakura et al., 2007). Hence, the study of the effects of both aeration and aquaria design seems to be necessary to achieve a satisfactory water dynamics in the aquaria.

Another environmental factor that should be considered in the achievement of a successful rearing technique is the photoperiod regime (Partridge et al., 2011). It is known that light regime and aeration affect growth and survival of fish larvae (Partridge et al., 2011; Stuart and Drawbridge, 2012; Vallés and Estévez, 2013). Also, it has been pointed out that

photoperiod is related to a wide variety of behaviours and biological rhythms in fish larvae, depending on ecological requirements and species-specific characteristics (Fielder et al., 2002; Eshagh-Zadeh et al., 2013). Traditionally, extended daylight photoperiods have been applied to maximize food ingestion and growth in fish (Vallés and Estévez, 2013). However, the use of long photoperiod regimes is not a common practice in seahorses (Pawar et al., 2011). Even though adequate light cycles might enhance growth and survival rates, there is high controversy on the identification of the most adequate photoperiod regime (Fielder et al., 2002; Campagnolo and Nuñez, 2008; Partridge et al., 2011). The impact of photoperiod regimes on seahorses have been scarcely studied (Sheng et al., 2006; Olivotto et al., 2008; Martínez-Cardenas and Purser, 2012) and, due to its species-specific effects, it becomes of main importance to determine the optimum photoperiod regime for each species.

The main objective of the present study was to improve the early rearing of *Hippocampus guttulatus* juveniles by assessing photoperiod regimes (Long vs short cycle), aeration levels (Strong vs weak) and, for the first time in seahorse studies, aquaria designs (rectangular, spherical and pseudoKreisel).

1.2. Materials and methods

1.2.1. Broodstock

Adults of the seahorse *Hippocampus guttulatus* were collected by scuba diving from winter to summer in 2010 at several locations of the Galician coast (NW Spain) and properly transported to the facilities of the Institute of Marine Research in Vigo (Spain). Prior to be transferred to 630 l aquaria units, seahorses were gradually acclimatised to room temperature for 3-5 hours, and then weighed and tagged using nylon collars with a unique code for individual identification (Planas et al., 2008b).

The breeders were submitted to standardized photoperiod and temperature regimes (Planas et al., 2010a, 2013). The temperature level was gradually adjusted according to a natural-like temperature cycle, ranging from 15 °C in winter to 19 °C in summer (± 0.5 °C), whereas the photoperiod regime was increased from 10L:14D (winter conditions) to 16L :8 D (summer conditions). The breeding aquaria were supplied with 5 μ m-filtered and UV-treated seawater with a daily renewal of 10-15 % total volume. Water quality was periodically

checked for NO_2 , NO_3 and NH_4/NH_3 content (0 mg L^{-1}) by using Sera Test Kits. Salinity and pH levels were 38 ± 1 ppt and 8.1 ± 0.1 , respectively.

The adult seahorses were fed twice per day on adult enriched *Artemia* (EG; Iberfrost, Spain) and supplemented with wild-captured Mysidacea (*Leptomysis* sp. and *Siriella* sp.). *Artemia* enrichment consisted on a mixture of microalgae (*Phaeodactylum tricornutum* and *isochrysis galbana*) and a daily dose (0.1 g l^{-1}) of Red Pepper (Bernaqua, Belgium) for at least 5 days. Faeces and uneaten food were siphoned every day before feeding.

Pregnant seahorses were transferred individually from the broodstock aquaria to 30L pseudoKreisel aquaria ($18 \text{ }^\circ\text{C}$ and 16L:8D light regime) and maintained isolated for a few days until newborn release.

1.2.2. Rearing system

Newborn from different batches (October 2011 - January 2013) were used in the present study and were transferred to the experimental aquaria at an initial density of 4 juvenile L^{-1} . The rearing aquaria were operated in a semi-opened recirculation system including a degasifying column and two 50 L biofilters with mechanical (up to $20 \mu\text{m}$) and biological filters, aerators and skimmers. The seawater was pumped from the biofilters to 36w UV units and from there to 50 L reservoir tank, and finally routed by gravity towards the rearing aquaria (Figure 1).

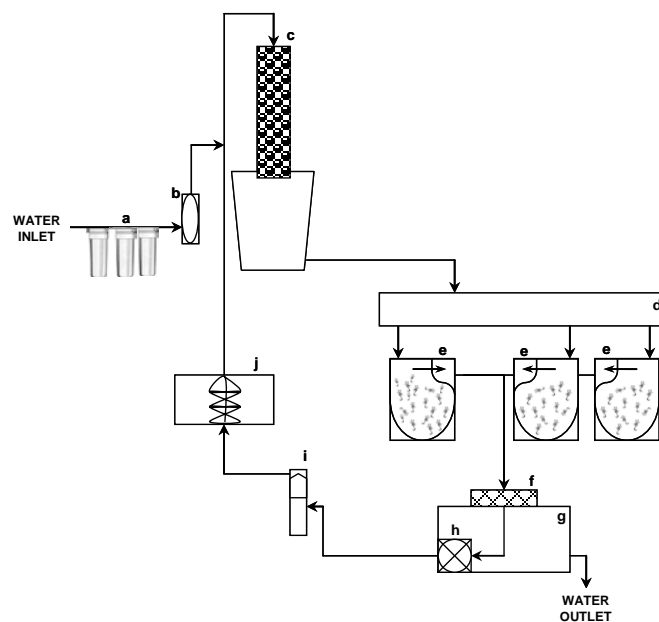

Figure 1. Experimental system for the rearing of *Hippocampus guttulatus* juveniles. a) Mechanical filters ($20\mu\text{m}$, $5\mu\text{m}$ and $1\mu\text{m}$), b) UV unit, c) Degasifying column, d) Water reservoir, e) Aquaria, f) Mechanical filter ($30\mu\text{m}$), g) Biofilter reservoir aquaria, h) Water pump, i) Skimmer, and j) Pump.

1.2.3. Experiment 1: Aquaria Design and Photoperiod

Aquaria design

Three types of aquaria were assayed (Figure 2):

- Rectangular (R): The aquaria were 335 x 195 x 220 mm in size (10 L useful volume). In addition to black walls (12 cm height) in the upper half of all aquaria sides, black upper covers were used (Figure 2.1). The water inflow was adjusted to 400 ml min⁻¹ and placed inside a tube located in the opposite side of the water outlet, which was situated 35 mm below the upper part of the aquaria and built on T-system. Two mesh sizes (150 mm radius) were used: 500 µm during daytime to allow the exit of remaining prey between feeding times and 250 µm at evening/night to avoid prey from leaving the aquaria. Aeration of the aquaria was provided by stand-pipes (5 mm in diameter) placed at the bottom of the aquaria.

- Spherical (SP). This aquarium (Figure 2.2) was a modification of 9 L transparent plastic flat-bottomed circular bowls (7.5 L useful volume) commonly used for fish keepers. The bowls had a 120 mm diameter opened top and the biggest diameter of the aquaria, measured at the middle part, was 240 mm. The water inflow (300 ml min⁻¹) was placed in the upper part of the aquarium, flowing through the wall to avoid a cascade effect while providing top-down water currents. The water outlet was located in the centre of the bottom of the aquaria and consisted of a vertical double tube system. The inner tube (175 mm in length and 10 mm radius) was placed at the level of water surface and served as water outflow. The external tube (16 mm radius and 210 mm in length with a 500 µm mesh) was used for protection impeding seahorse juveniles to be drained out. Moderated aeration was provided by a stand-pipe attached to the external central tube, in opposite position to the water inflow.

- PseudoKreisel (PK). This polyurethane aquarium (27 L useful volume) was designed as a modification of a common Kreisel aquarium including a combined circular (Upper part) and rectangular (Lower part) shape (Figure 2.3). The water inlet was located in one of the surface corners (flow rate: 700mm min⁻¹) and opposite to the outflow box. The water outlet consisted of an outflow box with two smaller compartments. The first one determined the upper level of the water column. From there, the seawater was transferred to a second compartment from where the water was discarded. The first compartment was screened (9 x 12 mm) towards the main compartment of the pseudoKreisel vessel. A 500 µm mesh was placed on it during the day-time period of the day and substituted by a 250 µm mesh during the night. Aeration was provided by a stand-pipe placed below the outflow box.

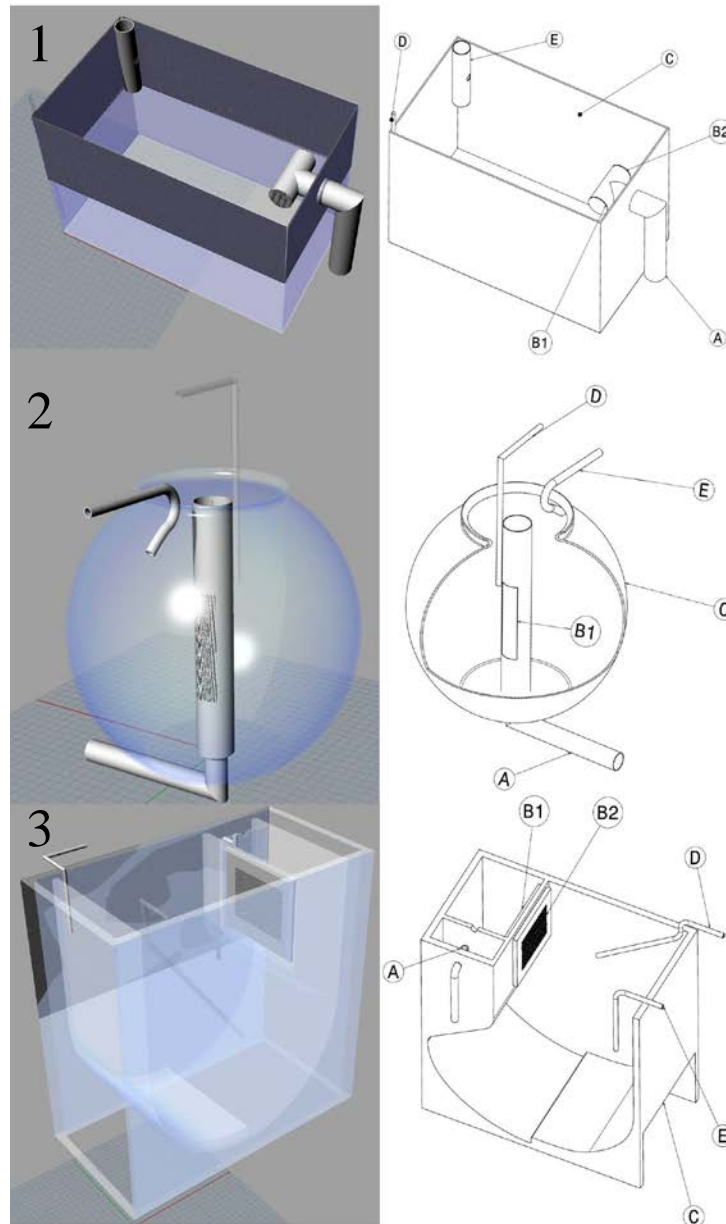

Figure 2. Aquaria used in the rearing of seahorse juveniles. Left: 3D drawing, Right: Detailed drawing. 1) Rectangular aquarium; 2) Spherical aquarium; 3) PseudoKreisel aquarium. A) Water outlet; B) Screened mesh (B1: 500 μm and B2: 250 μm); C) Aquaria wall; D) Air pipe; and, E) Water inlet.

Photoperiod regimes

Two photoperiod regimes, 16L:8D (natural-like) and 24L:0D (extended), were applied to the three experimental aquaria types above described. Lighting was supplied by 20w fluorescent lamps (Power Glo) during the day-time (from 08.00 to 18.00 in the 16L:8D treatment or 24h in the 24L:0D treatment). In rectangular and circular aquaria, the lamps were placed approximately 30 cm above the seawater surface whereas the lightning was lateral in pseudoKreisel aquaria. To avoid light entering from the surface of the water column in rectangular and pseudoKreisel aquaria, the half upper sides of the walls were covered by

black plastic films. The top of the rectangular aquaria were also covered by plastic lids. In spherical aquaria, the lamps were covered by a black translucent mesh to avoid brightness in the water surface.

Feeding conditions

For the aquaria design and photoperiod experiments, seahorse newborn were fed on a single daily dose of copepods (09.00h; 0.6 copepods ml⁻¹) and *Artemia* nauplii (18.00h; 1 *Artemia* ml⁻¹) from 0 to 10 DAR (days after male's pouch release). Three daily doses (09.00, 13.00, 17.00) of *Artemia* nauplii and 24 h enriched metanauplii (1:1, 1 *Artemia* ml⁻¹ dose⁻¹) were offered from day 11 until the end of the experiment at day 30. Copepods were cultivated on a mixture of the microalgae *Isochysis galbana* and *Rhodomonas lens*. *Artemia* enrichment was performed in 5 L buckets at 26 °C at initial density of 100 *Artemia* ml⁻¹. The enrichment diet consisted of a mixture of the microalgae *I. galbana* (10⁷ cells ml⁻¹) and *Phaeodactylum tricornutum* (1.6 10⁷ cells ml⁻¹).

Twice daily, wastes and faeces were siphoned out and dead seahorses removed and counted. Experiments finished at 30 DAR, when all survivors were counted. Samples of seahorses were taken at 0, 5, 10, 15 and 30DAR for wet weight and standard length.

1.2.4. Experiment 2: Aeration Intensity

Strong and weak aeration conditions were assayed in juveniles reared in pseudoKreisel aquaria. Strong aeration was supplied by a stand-pipe producing big air bubbles (24 ± 3 mm in diameter) from the upper half side of the pseudoKreisel aquaria, near the outflow screened window. Approximately 11 ± 1 air bubbles sec⁻¹ were supplied at a mean velocity of 42 ± 3 cm sec⁻¹. Weak aeration was provided from the lower half side of the aquaria, below the outflow box (Figure 2.3), by small air bubbles (11 ± 2 mm in diameter) moving at a speed of 37 ± 3 cm sec⁻¹ at a rate of 21 ± 3 bubbles sec⁻¹.

The feeding schedule applied consisted of three daily doses of *Artemia* nauplii (1 *Artemia* ml⁻¹) from 0 to 10 DAR and three daily doses of *Artemia* nauplii and 24 h enriched metanauplii (1:1, 1 *Artemia* ml⁻¹ dose⁻¹) from 11 DAR until the end of the experiment at day 30. *Artemia* enrichment was carried out as previously described in Experiment 1.

Fish faeces and uneaten food were siphoned out twice daily and dead seahorse juveniles removed and counted. At the end of the experiment (30 DAR), five survivors from each treatment were individually weighted and measured for SL.

1.2.5. Sampling and data analysis.

Seahorse samples (n=10-20) were taken at 0, 5, 10, 15 and 30DAR in Experiment 1 and at 0, 15 and 30 DAR in Experiment 2. Sampled seahorses were anaesthetised with MS222 (0.1 g L⁻¹), washed with tap water, transferred individually to Petri dishes and photographed for standard length (SL) measurements. Then, the excess of water was removed and the seahorses were pooled or individually weighted on a Sartorius microbalance MC210P (\pm 0.01 mg). Seahorses from samples taken at 30 DAR were awoken and transferred to their original aquaria. Estimated final survivals were adjusted considering sampling mortality.

SL was measured as head + trunk+ tail length (curved measurement), as reported by Lourie et al. (1999). Measurements were made on digital images using an image processing software (NIS, Nikon). Calculations involving development and growth were performed according to the formulations described in Otterlei et al. (1999) and applied to *H. guttulatus* juveniles by Planas et al. (2012). Daily weight-specific growth rates (G; % day⁻¹) were calculated as:

$$G = 100 (e^g - 1)$$

where the instantaneous growth coefficient g was obtained by the following equation

$$g = (\ln W_2 - \ln W_1) / (t_2 - t_1)$$

where W_2 and W_1 are the average wet weights (mg) at times (in DAR) t_2 and t_1 , respectively. Fulton's condition factor (K_F) of juveniles was calculated as:

$$K_F = (WW/SL^b) * 1000$$

where WW was the wet weight and SL the standard length, b was the constant from the power tendency of the WW – SL relationship.

All statistical analyses were done using the software packages SPSS 21.0 and STATISTICA 8.0. To analyse differences in WW and SL among treatments, MANOVA tests were performed considering a significance level of $P < 0.05$. Levene's test and residual plots were used to test homoscedasticity. Bonferroni *post-hoc* test was used to identify differences between treatment means.

One-way ANOVA was used to test for differences among DAR for each experimental treatment (Experiment 1 and Experiment 2). Additionally, in Experiment 1, three-way ANOVA test was used to assess differences between photoperiod, aquaria design and their

interaction at each established developmental stage (5, 10, 15 and 30DAR). In both experiments, differences were tested at a significance of $P < 0.05$. Partial squared eta (η^2) was used as a measure of effect size as it is independent of the ANOVA design used (Chu et al., 2012). Levene's test and Shapiro-Wilks normality test were applied to test for homogeneity and normality, respectively, for all samples. Bonferroni *post-hoc* comparisons were analyzed between the different means when statistical differences were found.

1.3. Results

1.3.1. Experiment 1: Aquaria Design and Photoperiod

The effect of photoperiod regime and aquaria type on survival rates of seahorse juveniles at different DAR are summarized in Table 1 (Three-way ANOVA) and depicted in Figure 3 (Aquaria type: A-B; Photoperiod: C-E). First order and second order interactions were all statistically significant (except for photoperiod x DAR). Overall, survivals were significantly higher in pseudoKreisel aquaria under a 16:8 photoperiod regime and decreased from 0 to 30 DAR, though they remained constant from 10 to 15 DAR.

Table 1. Analyses of variance (3-way ANOVA) on the effects of the photoperiod, aquaria design and age on the survival of *Hippocampus guttulatus* juveniles

Source	df	Squared mean	F	Significance
Aquaria Type	2	6988	40.50	0.000
Photoperiod Regime	1	3506	20.32	0.000
DAR (Age)	3	9264	53.69	0.000
Aquaria x Photoperiod	2	1095	6.35	0.000
Aquaria x DAR	6	1001	5.80	0.004
Photoperiod x DAR	3	285	1.65	0.189
Aquaria x Photoperiod x DAR	6	185	1.08	0.390
Error	48	172		

The photoperiod regime did not affect survivals in pseudoKreisel aquaria ($p=0.805$). However, a long photoperiod had a significant negative impact on survivals in both rectangular ($p=0.026$) and spherical ($p<0.001$) aquaria.

Considering the aquarium type, pseudoKreisel and spherical units performed similarly ($p=0.572$) under a short photoperiod regime. Survivals were significantly lower in the

rectangular aquaria ($p < 0.001$). Under a continuous light regime, survivals in spherical and rectangular aquaria were not significantly different ($p = 0.961$) but notoriously lower than in pseudoKreisel units ($p < 0.001$, in both cases).

Changes in survival with age were clearly affected by both photoperiod regime and aquarium type. A significant effect of photoperiod was noticed at 10 and 15 DAR ($p = 0.001$ and 0.004 respectively) but not at 5 and 30 DAR ($p = 0.410$ and 0.129 , respectively). Considering aquarium type, survivals did not differ significantly at 5 DAR. In pseudoKreisel and spherical types, seahorses performed similarly at 10 DAR ($p = 0.119$), and survivals in the former were significantly higher than in rectangular aquaria ($p < 0.001$). Since 10 DAR until the end of the experiment, survivals in pseudoKreisel aquaria were higher than in spherical and rectangular units ($p = 0.005$ and $p < 0.001$). At 15 and 30 DAR, spherical and rectangular aquaria performed similarly ($p = 0.09$ and 0.228 , respectively).

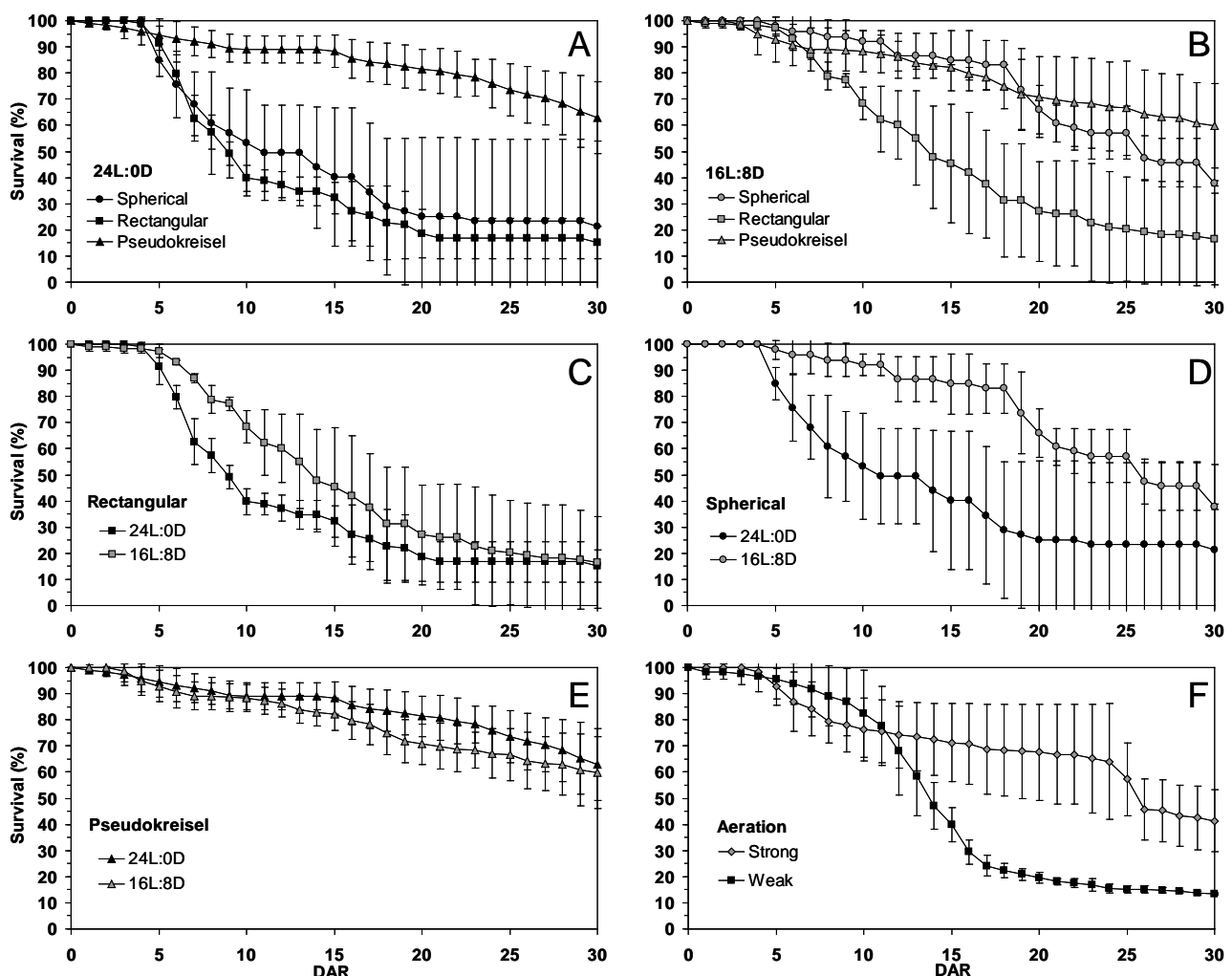

Figure 3. Survival rates in seahorse juveniles grown under different conditions. Experiment 1 (A-E): Effect of aquaria type under two photoperiod regimes (A: natural photoperiod 16L:8D; B: extended photoperiod 24L:0D) and effect of photoperiod regimes on three aquaria types (C: Rectangular; D: Spherical aquaria; E: PseudoKreisel). Experiment 2 (F): Effect of aeration (strong and weak) in pseudoKreisel aquaria.

Wet weights and standard lengths in seahorses reared in different aquarium types under two photoperiod regimes are shown in Figure 4A.

Mean comparisons showed significant differences in WW and SL between 0 and 30 DAR in all aquaria types and photoperiod regimes (One-way ANOVA, $p < 0.05$). The MANOVA test applied to both WW and SL in 30 DAR juveniles showed non-significant effects for the interaction aquaria type - photoperiod regime (MANOVA $F_{4, 104} = 2.16$, $p = 0.08$, $\eta^2 = 0.077$). Additionally, no significance was achieved for main effects of aquaria design (MANOVA $F_{4,104} = 2.28$, $p = 0.08$, $\eta^2 = 0.081$) and photoperiod (MANOVA $F_{2,52} = 0.72$, $p = 0.49$, $\eta^2 = 0.027$). However, WW in 30 DAR juveniles from spherical aquaria under the natural photoperiod (130 ± 19 mg) was higher but not statistically different than in juveniles from rectangular (69 ± 20 mg) or pseudoKreisel (77 ± 8 mg) aquaria.

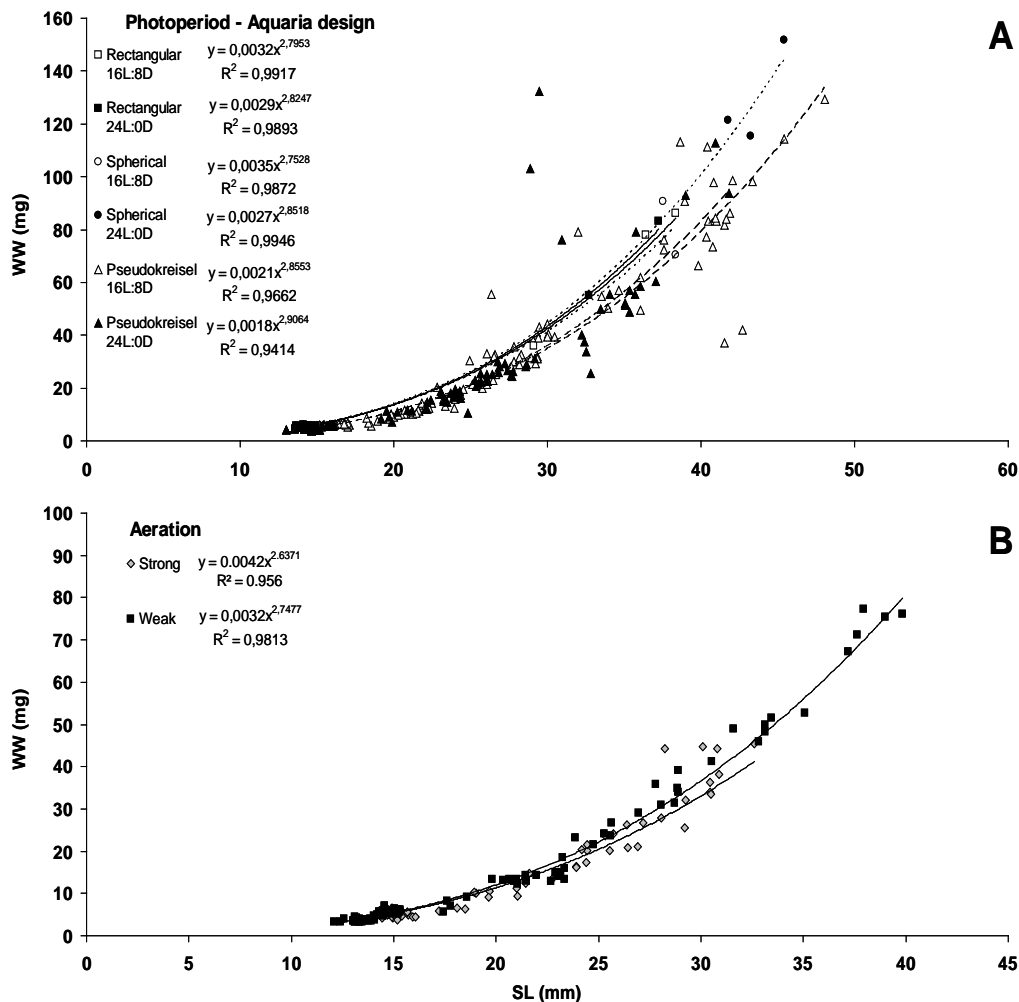

Figure 4. Wet weight (WW) and standard length (SL) relationships in A) Experiments 1: Photoperiod – Aquaria design, and B) Experiment 2: Aeration level.

Gs from 0 to 30 DAR and Fulton's condition factors (K_F) at 30 DAR were not statistically different among treatments except K_F for the three aquaria types (ANOVA, $F_{2,10}=10,96$, $p=0.003$). K_F in juveniles were significantly lower in pseudoKreisel aquaria ($p=0.09$ and 0.010 for spherical and rectangular aquaria, respectively).

1.3.2. Experiment 2: Aeration Intensity

Figures 3F and 4B show survival rates and WW-SL relationships in juveniles submitted to weak and strong aeration. The interaction aeration – age (DAR) in between-subject effect was statistically significant (MANOVA $F_{2,434} = 10.35$, $p < 0.001$) for both WW and SL. Pair-wise statistical differences for WW and SL were obtained at 15 and 30 DAR. WW in 15 DAR juveniles reared under weak aeration was higher than in those submitted to strong aeration (19.7 ± 1.4 and 14.7 ± 1.6 mg, respectively); such differences were also found in 30 DAR juveniles (48.9 ± 1.9 mg and 32.8 ± 1.9 mg, respectively). Similarly, seahorses reared under weak aeration showed higher SL than those reared under strong aeration both at 15 DAR (23.4 ± 0.4 mm and 22.1 ± 0.5 mm, respectively) and 30 DAR (32.3 ± 0.6 mm and 29.0 ± 0.6 mm). However, survival rates clearly showed an opposite pattern (One-way ANOVA $F_{1,4} = 11.09$, $p = 0.03$).

During the first days of live, juveniles grown in pseudoKreisel aquaria were rather well distributed in the water. The design of that type of aquarium and the water circulation impeded the accumulation of juveniles in stagnant regions. More importantly, the presence of seahorses at water surface was significantly reduced, impeding the development of swim bladder hyperinflation and further death of the juveniles affected. Survivals in 15 DAR juveniles from strong aeration aquaria were notoriously higher (71 ± 15 %) than those raised from weakly aerated aquaria (40 ± 6 %). The same finding was encountered at 30 DAR (41 ± 12 and 13 ± 0 % for strong and weak aeration, respectively). Most differences in survivals among treatments occurred from 10 DAR onwards.

1.4. Discussion

The results achieved in the present study have demonstrated that the best performance in the early rearing of seahorses, especially in terms of survival rates, was achieved in pseudoKreisel aquaria under a strong aeration and, to a lesser extent, a day-night photoperiod

regime. Clearly, aquaria shape and aeration were pivotal factors interfering with juvenile viability.

The design of aquaculture rearing aquaria should consider some basic principles such as good water mixing, solids removal, minimal stagnant regions and even distribution of food and fish in the media, among others (Cripps and Poxton, 1992). Despite evenness fish distribution is related to rearing aquarium design (Duarte et al., 2011), there are no previous studies on the survival and performance efficiency of different aquaria shapes in the rearing of seahorses. Our results showed a clear effect of aquaria design on survival of seahorse juveniles. The three types of aquarium tested in the present study differed in shape and also in other characteristics. Darkening different zones of the aquaria has been widely used to reduce upper lightening and maintain phototactic prey away from the surface, which may help to achieve an even fish distribution (Moore et al., 1994; Naas et al., 1996; Martinez et al., 2005). On this regards, rectangular as well as pseudoKreisel aquaria were wall-blackened in the upper half of the aquaria to help with the food and seahorse juveniles (positive phototactic response) on their migration to deeper regions of the water column. On the contrary, due to the reduced water surface of the circular aquaria, their rounded walls were not darkened.

Another important difference among the experimental aquaria was the placement of the water inflow and outflow. Spherical and pseudoKreisel aquaria had the inflow placed outside but near the water surface (attached to an aquarium wall) providing a water-cascade and/or a circling water current. Additionally, the opposite placement of the water inlet and the aeration pipe in those aquaria improved the water circulation and the distribution of prey items and seahorse juveniles. On the contrary, the water inlet in the rectangular type was placed below the water column, inside a protection tube, and the water was projected through a small hole (see Figure 2.1). The circular water flow in spherical aquaria and the top-down flow in rectangular aquaria did not performed differently considering juveniles survival. However, poor water mixing conditions and non-adequate prey/juveniles distribution was observed in the later by creating irregular and unpredictable flow patterns, which is in agreement with Oca et al. (2004). This resulted in earlier mass mortalities (>50% at 15 DAR). Circular water flow in spherical aquaria with a unique water jet might also difficult a uniform fish distribution (Rosenthal, 1989) which might have increased mortalities thorough the experiment (>60% at 30 DAR).

Commonly, rectangular and circular units are the most widely used in fish larviculture and also in the breeding and rearing of some seahorse species. The former have been traditionally used in the rearing of juveniles of *H. subelongatus* (Payne and Rippingale, 2000), *H. erectus* (Gardner, 2008; Lin et al., 2010), *H. hippocampus* (Otero-Ferrer et al., 2010), *H. reidi* (Olivotto et al., 2008; Hora and Joyeux, 2009), *H. kuda* (Job et al., 2002) and *H. guttulatus* (Palma et al., 2011). Moreover, circular shaped aquaria (from cylindrico-conical to round and circular bowls) have been used in the culture of *H. abdominalis* (Woods, 2000a, 2003b, 2003c), *H. barbouri* (Wilson and Vincent, 2000; Payne, 2003), *H. kuda* (Wilson and Vincent, 2000; Sheng et al., 2007), *H. fuscus* (Wilson and Vincent, 2000) and *H. trimaculatus* (Sheng et al., 2007). The use of aquaria with uncommon shapes and types has been also reported, e.g. bamboo cages in *H. kuda* and *H. barbouri* juveniles (Garcia and Hilomen-Garcia, 2009; Garcia et al., 2010) or plastic buckets in *H. trimaculatus* (Sheng et al., 2006).

Changes in physiology, activity and behaviour of fish have been related to poor water mixing (Duarte et al., 2011). Vertical circulation patterns have been reported as beneficial in seahorse rearing by preventing juveniles from becoming trapped at the water surface (Gomezjurado and Gardner, 2005). PseudoKreisel aquaria, as a modification of the traditional Kreisel aquaria, have been described to alleviate that constrain in the rearing and maintenance of animals that need an even distribution and a continuous water movement such as jellyfish (Widmer et al., 2005; Rackmil et al., 2009) or lobsters (Tlustý et al., 2005). The use of pseudoKreisel aquaria, similar to those used here, has also been reported in the rearing of *H. ingens*, *H. erectus* and *H. reidi* (Burhans, 2004; Gomezjurado, 2005; Gomezjurado and Gardner, 2005; Martínez et al., 2005). The design of the pseudoKreisel aquaria used in the present study hugely improved both water circulation and fish distribution. Indeed, the joined action of the water inlet and the relative position of the aeration pipe permanently forced juveniles to disperse in the rearing media. The consequence was a huge improvement in the rearing of seahorses and a high final survival (up to 77%).

Most problems related to seahorse rearing are related to feeding issues or fish diseases (Wilson and Vincent, 2000; Olivotto et al., 2008; Planas et al., 2010a). Seahorse newborn are completely developed and ready to swim and feed. Newly released newborn instinctively swim to the water surface to capture air for swim bladder inflation (Woods, 2000a). Surface crowding has been related to occur prior to the appearance of high mortalities in the rearing of several marine fish species (Harboe et al., 1998; Cunha and Planas, 1999). The appearance of

dysfunctions in swim bladder inflation (hyperinflation) and the ingestion of air bubbles have been strongly related to the photoperiod regime applied in phototactic marine fish larvae, being the origin of high mortalities (Nash et al., 1977; Woods, 2000a; Fielder et al., 2002; Stuart and Drawbridge, 2012). Day-night cycles are highly related to fundamental biological endogenous and exogenous rhythms caused by the pineal organ hormonal secretion (Campagnolo and Nuñez, 2008). Endogenous rhythms such as circadian feeding rhythms can be synchronized by daily oscillations (e.g. light) while exogenous rhythms are completely controlled by external factors and would change rapidly when these factors change (Sheng et al., 2006). Modifications of the factors that influence on the hormonal rhythm secretion affect to fish larvae development and compromise the survival and performance of young fish (Campagnolo and Nuñez, 2008).

Nevertheless, not all fish species would be similarly affected by artificial modifications of the photoperiod since most large-scale cultures are commonly performed under a continuous light regime during the early developmental of fish. Olivotto et al. (2008) pointed out that *Hippocampus reidi* juveniles cultured in rectangular aquaria on a mixed diet including copepods performed and survived better when exposed to extended photoperiods than juveniles reared under natural photoperiod conditions. On the contrary, survivals in *H. abdominalis* reared under a 16L:8D cycle did not differ from those achieved under either extended or shortened photoperiods, though juveniles grew better under a day-night cycle (Martinez-Cardenas and Purser, 2012). In the present study, no differences were found on survival or performance of *H. guttulatus* juveniles when comparing extended and natural photoperiod regimes.

In culture conditions, the feeding ability of active visual predator fishes has been also widely related to the photoperiod regime (Fielder et al., 2002; Olivotto et al., 2008; Partridge et al., 2011; Martinez-Cardenas and Purser, 2012; Stuart and Drawbridge, 2012; Eshagh-Zadeh et al., 2013; Vallés and Estévez, 2013). The rearing of seahorses has been generally carried out under day-night cycles. A 14L:10D cycle has been used in *Hippocampus barbouri* (Wilson and Vincent, 2000; Payne, 2003), *H. comes* (Job et al., 2006), *H. erectus* (Zhang et al., 2011), *H. fuscus*, *H. kuda* (Wilson and Vincent, 2000), *H. guttulatus* (Faleiro and Narciso, 2010), *H. reidi* (Pham and Lin, 2013), and *H. trimaculatus* (Sheng et al., 2007) and 12L:12D cycles in *Hippocampus abdominalis* (Woods, 2000a, 2003c), *H. erectus* (Yin et al., 2012), *H. reidi* (Hora and Joyeux, 2009; Willadino et al., 2012; Souza-Santos et al., 2013), *H.*

subelongatus (Payne and Ripplingale, 2000), and *H. whitei* (Wong and Benzie, 2003). However, *H. erectus* and *H. capensis* have been reared under a 16L:8D photoperiod (Lockyear et al., 1997; Lin et al., 2010) whereas *H. reidi* and *H. kuda* have been successfully reared under continuous light (Olivotto et al., 2008; Pawar et al., 2011). Sheng et al. (2006) observed active feeding and swimming during the day-light period but reported abnormally floating juveniles at night.

Morphological features (big eyes and lack of lateral line) in seahorses suggest that seahorses are active ambushers and visual feeders. It has been reported that the activity of *H. kuda* (Sheng et al., 2006) and *H. abdominalis* (Martinez-Cardenas and Purser, 2012) is highly reduced at night, even in 24h of light extended photoperiods. However, hunting activity in marine fish larvae increases proportionally with the extension of the light period (Fielder et al., 2002; Stuart and Drawbridge, 2012). These authors also pointed out that increasing levels of activity are accompanied by increasing energy expenditure for foraging and swimming. The results achieved on growth and survival of *H. guttulatus* juveniles under both natural and extended photoperiod regimes might be explained through the imbalance between the ingested and mobilized energy. Under a continuous light regime, there is a compromise between the energy expenditure for actively feeding activities and the energy allocated for growth. Under a day-night cycle, however, the energy saved at night due to a reduced locomotion activity might be used for growth, which would be advantageous, especially during the first critical days when the efficiency of food digestion and assimilation is still scarce (Cunha et al., 2007; Blanco et al., 2011a, 2013). The final rearing success, mainly in terms of growth, would depend on the resulting net efficiency between gained and consumed/assimilated energy in both the light and the dark periods of the day. In addition to energy balances, day and night periods may also affect to other physiological aspects of fish. Hence, the application of an adequate photoperiod regime should be established accordingly.

The energy required for swimming, hunting, feeding and growth is closely related to water turbulence (Nash et al., 1977; Utne-Palm and Stiansen, 2002; Oshima et al., 2009). Seahorse specific daily growth rates are enhanced under lower water turbulence environments. This fact is very likely due to an increasing difficulty for capturing prey in strong water currents (Utne-Palm and Stiansen, 2002; Oshima et al., 2009). It has been pointed out that survival rates in *H. hippocampus* were quite low (11%) under strong aeration conditions, yet total early mortalities in juveniles reared under moderated aeration were also

recorded (Molina et al., 2007). Similar trends were obtained in the present study, in which significantly higher survival rates were achieved in the early rearing of *H. guttulatus* under strong aeration conditions when compared to those raised under a weak aeration, especially from 15 DAR onwards. Final survivals at 30 DAR in strongly aerated aquaria were three-folds higher than in aquaria with weak aeration (41 ± 12 and $13 \pm 0\%$, respectively). However, growth rates were lower in the former, which is in agreement with the statement of higher energy expenditure in more turbulent environments.

Strong turbulence has been considered a mortality causative factor due to potential physical hitting of fish larvae (Sakakura et al., 2007). However, the bony plated skeleton in seahorses as well as their vertical positioning provides them a hardness shielding against impacts and crushing (Porter et al., 2013). In our study, seahorse juveniles under a strong turbulence did not suffer mechanical damages, showing much higher survivals and lack of swim bladder hyperinflation in most of them. It has been reported in young fish that high turbulence conditions promote a reduction in swimming activity and avoids their accumulation near water surface (Utne-Palm and Stiansen, 2002; Sakakura et al., 2006). In agreement with that, in the present study *H. guttulatus* juveniles were observed to swim passively due to the water current generated by big bubbling under strong aeration conditions. More developed juveniles were found to be better distributed in the aquaria and actively swimming against the water currents provided by a strong aeration.

In spite of the above referred effects of water turbulence of energy expenditure of juveniles and their distribution in the media, the type of aeration had very likely much more impact on the appearance of swim bladder hyperinflation in young seahorses. These advanced teleost fish are physoclistus, lacking an air transportation duct connecting the lumen of the gas bladder to the external environment. Consequently, they must gulp air at water surface to inflate the swim bladder (Fielder et al., 2002; Anderson and Petty, 2013). Swim bladder inflation in *H. guttulatus* generally occurs during the first hours of life and under adequate conditions all juveniles have the swim bladder normally developed by 1-2 DAR. When present, abnormal swim bladder hyperinflations commonly appeared from day 5 to 10, with juveniles floating passively at water surface, but most affected juveniles died in the following days mainly due to difficulties in prey capture. Swim bladder hyperinflation is a serious and a common problem that may drastically affect to rearing viability, being present when young juveniles with normally developed swim bladders remain for long time near the

water surface. Conversely to juveniles reared under strong aeration in pseudoKreisel aquaria, the cultures carried out in the present study under weak aeration conditions clearly enhanced the development of hyperinflated swim bladder in juveniles, resulting in considerably lower final survivals.

1.5. Conclusions

Considering the whole results achieved in the present study on the rearing of juveniles of the seahorse *Hippocampus guttulatus* under different aquaria types, photoperiod regimes and aeration conditions, we recommend for better rearing performances that the early culture to be carried out in pseudoKreisel aquaria with strong aeration and a day-night light cycle (16L:8D). Under those conditions, the appearance of swim bladder hyperinflation resulted drastically reduced and the final survivals were radically increased.

CHAPTER 2

**Temperature-induced changes of growth and survival in the early
development of the seahorse *Hippocampus guttulatus***

Temperature-induced changes of growth and survival in the early development of the seahorse *Hippocampus guttulatus*

This chapter has been published in:

Journal of Experimental Marine Biology and Ecology

<http://dx.doi.org/10.1016/j.jembe.2012.10.003>

ABSTRACT:

The effect of temperature (15, 18 and 21°C) on the early development of the long-nouted seahorse *Hippocampus guttulatus* were analysed, both under feeding (until day 30 post partum) and starving conditions. Fed and starving seahorses maintained at 15 °C grew at suboptimal conditions. At this temperature, mortalities started earlier and the swimming activity was reduced. In fed juveniles, final survivals (21.1, 85.9 and 81.1% at 15, 18 and 21 °C, respectively) and wet body mass (14.7, 51.9 and 106.43 mg at 15, 18 and 21 °C, respectively) were significantly different. The dependency of daily weight specific growth rate (G ; % day⁻¹) on temperature (T ; °C) was explained by the function: $G = -32.905 + 2.8079T - 0.00166T^3$. Three development scales were compared for temperature-dependency: chronological time (days), day-degrees (D°) and effective day degrees (D°_{eff}). It was demonstrated, within a viable temperature range, the suitability of D°_{eff} as a temperature-independent scale to quantify growth in feeding juveniles but not in starving conditions. Seahorse wet weight was modelled as a function of time scales and temperature according to a modification of the Gompertz model. Growth models for single temperatures in the range 14 – 26 °C were constructed. D°_{eff} was the only scale that allowed a good temperature-independent fitting of seahorse weight (W ; mg) in a unique equation: $W = 7.409 - 0.0555 D^{\circ}_{\text{eff}} + 0.0037 D^{\circ}_{\text{eff}}{}^2 - 0.000006 D^{\circ}_{\text{eff}}{}^3$. Biological, ecological and biogeographic implications of temperature in the early development of the viviparous fish *H. guttulatus* are discussed. Finally, from a practical point of view, temperatures of 19-20 °C are recommended for the rearing of this species in captivity.

2.1. Introduction

Although the knowledge on the biology of seahorses (*Hippocampus* spp.) has been increasing in the last decade, there is a lack of information on many aspects for most species. Seahorses are threatened or endangered species worldwide distributed from 50° North to 50° South latitudes, mainly in the Indo-Pacific region (Olivotto et al., 2011). Seahorses from tropical regions are adapted to higher temperatures than sub-tropical or temperate seahorses. It is known that temperature, due mainly to latitude, determines to a large extent differences in many biological and physiological processes, such as the duration of the breeding period or the size of adults, eggs and newborn among seahorse species (Foster and Vincent, 2004). However, the optimal temperature, ranges for most species are unknown for adults and especially for juveniles.

Temperature plays a pivotal role in fish (Blaxter, 1991) and exercises a strong influence on the survival, growth and energetics of marine fish larvae (Houde, 1989; Olivotto et al., 2006). The effect of temperature on some aspects concerning growth, survival or reproduction has been demonstrated for a limited number of seahorse species: *H. abdominalis* (James and Woods, 2001), *Hippocampus whitei* (Wong and Benzie, 2003), *H. kuda* (Lin et al., 2006) and *H. guttulatus* (Planas et al., 2010a). In the European long-snouted seahorse *H. guttulatus* submitted to winter or summer light regimes and temperatures of 15, 18 and 21 °C, female maturation is mainly controlled by light regime, with higher performances for increasing temperature levels (Planas et al., 2010a). *H. guttulatus* is a temperate species distributed from British Isles to Morocco, Canary Islands, Madeira, Azores and the Mediterranean Sea, with a breeding season extending from April to October (Boisseau, 1967; Lythgoe and Lythgoe, 1971; Reina-Hervás, 1989; Curtis and Vincent, 2006),

Water temperatures during the breeding season of *H. guttulatus* vary largely depending on the region considered (Reynolds and Smith, 1995). Temperatures in the South of the Iberian Peninsula, Canary Islands or Mediterranean differ notably from those in the North of Spain, France or British Isles. Thus, adults of this species seem to be adapted to a wide range of temperatures. For example, in the Ria Formosa, where an important population of *H. guttulatus* is present, the water temperature varies annually between 10 and 28 °C, with a mean temperature of 18.2 °C (Curtis and Vincent, 2005). However, it is very likely that temperature exert an important limiting role in the geographical distribution of the species as

its northern distribution does not extend beyond the Irish and British waters (Holmes and Holmes, 1991; Garrick-Maidment, 1998; Wheeler et al., 2004).

In newborn and juveniles, there is a lack of information on their optimal environmental conditions due to the difficulty of being captured in nature. The reproductive activity in this species is directly correlated with the water temperature and the natural light regime, both in the wild (Curtis and Vincent, 2006) and in captivity (Planas et al., 2010a, b). During the first 1-2 months of life, juveniles are planktonic, exposed to water currents and dependent on the availability of natural prey. Although the early development of young seahorses coincides with the warmer season of the year, whose temperature differs depending on the geographical latitude, the initial growth and survival would be certainly affected by the local temperature level. However, the range of temperature tolerance in newborns and the implications of the temperature level are unknown.

Optimal ranges for most environmental factors can be inferred from experimental studies performed in mesocosm in which certain factors can be fixed avoiding the interaction with the studied. In the present study, temperature-induced changes during the early life of the seahorse *H. guttulatus* were evaluated in mesocosm. Two experiments were conducted with newborn seahorses at different temperatures, one under feeding and other under starving conditions. The effectiveness of three indices (day, day-degrees and effective day-degrees) as indicators of time in the early development of the seahorses was also evaluated. To our knowledge, this is the first study assessing temperature independency of several age scales in the early development of a viviparous fish, both under feeding and starving conditions.

2.2. Materials and methods

2.2.1. Broodstock.

Adult *Hippocampus guttulatus* were collected by scuba diving from winter to summer in 2010 in several locations of the Galician coast (NW Spain) and transported with surrounding water in plastic bags placed in isothermal polystyrene boxes to the facilities of the Institute of Marine Research in Vigo (Spain). After gradual temperature acclimation for 3-5 hours seahorses were weighed and tagged using nylon collars with a unique code for individual identification (Planas et al., 2008b). Subsequently, seahorses were transferred to 630 L aquaria units. Seawater temperature was gradually adjusted according to an annual

temperature cycle ranging from 15 °C in winter to 19 °C in summer (± 0.5 °C). A photoperiod cycle simulating that in the natural environment was applied (from 16L : 8D in June-July to 10L : 14D in December-January). A 10-15 % of the seawater was daily replaced with filtered (5 μm) and UV treated seawater. Water quality was checked periodically for NO_2 , NO_3 and NH_4/NH_3 content (0 mg L^{-1}) by using Sera Test Kits. Salinity and pH levels were 38 ± 1 ppt and 8.1 ± 0.1 , respectively.

Three times per day seahorses were fed *ad libitum* on adult *Artemia* enriched with mixtures of microalgae (*Phaeodactylum tricornutum* and *isochrysis galbana*) and one daily dose (0.1 g L^{-1}) of Red Pepper (Bernaqua, Belgium) for at least 5 days, and supplemented with captured Mysidacea (*Leptomysis* sp. and *Siriella* sp.). Faeces and uneaten food were siphoned out after feeding.

Two pregnant seahorses were transferred from the broodstock aquaria to 30L aquaria (18 °C and 12 L : 12 D light regime) and maintained isolated for a few days until the newborn release. Each pregnant male released one batch of newborns. Each batch was distributed into aquaria (5 newborn L^{-1}) and submitted simultaneously to feeding or starving conditions.

2.2.2. Rearing system.

The indoor experimental system for the rearing of newborn was maintained at room temperature (20-22 °C) and consisted in a group of three 30 L Kreisel-type aquaria for feeding experiments and a group of three 10 L rectangular aquaria for starvation experiments. In both cases, aquaria operated in a semi-opened recirculation system including a degasifying column and two 50 L biofilters with mechanical (up to 20 μm) and biological filters, aerators and skimmers. The seawater was pumped from the biofilters to 36 w UV light units and from there to 50 L reservoir tanks, being finally routed by gravity towards the rearing aquaria.

At the beginning of the experiments, the seawater temperature in the rearing system was 15 °C. During the following two days, the temperature in the rearing aquaria was progressively modified by means of an inlet heating system to reach the desired experimental temperatures of 15, 18 and 21 °C ($\pm 0.5^\circ\text{C}$), which were maintained constant until the end of the experiments. The total volume of the rearing system was renovated twice per hour by means of an external inflow (24 L h^{-1}) of 20 μm filtered and UV- treated seawater.

A photoperiod of 16L : 8D was applied and lighting was supplied by 20 w fluorescent lamps (Power Glo) placed laterally at 20 cm of the aquaria. To avoid light in the surface, the

aquaria were covered in the half upper sides of the walls by black plastic films (Kreisel and rectangular aquaria) and in the top by black plastic lids (rectangular aquaria).

2.2.3. Experiment 1: Feeding Conditions.

Two batches of newborn were raised (5 juveniles L⁻¹) separately at 15, 18 and 21 °C (two aquaria per temperature) in 30 L Kreisel-type aquaria and initially fed on a single daily dose (8 am) of cultivated copepods (*Acartia tonsa* and *Tisbe* sp) (0.6 copepods ml⁻¹) until day 5. A daily dose of copepods (10 am; 0.3 copepods ml⁻¹) and Great Salt Lake *Artemia* nauplii (1 *Artemia* ml⁻¹) were added from day 6 to 10 at 6 pm. Three daily doses of Great Salt Lake *Artemia* nauplii and 24 h enriched metanauplii (L *Artemia* ml⁻¹ dose⁻¹) were offered from day 11 until the end of the experiment at day 30. Copepods were cultivated in 250 – 500 L tanks at 26-27 °C and 38 ppt salinity and fed on mixtures of the microalgae *Isochysis galbana* and *Rhodomonas lens*, Only copepods retained by a 125 µm mesh were offered to seahorses. The enrichment of *Artemia* nauplii was performed in 5 L buckets at 26 °C and with initial densities of 100 *Artemia* ml⁻¹. The enrichment diet consisted of a mixture of the microalgae *I. galbana* (10⁷ cells ml⁻¹), *P. tricornutum* (1.6 10⁷ cells ml⁻¹) and *R. lens* (16⁷ cells ml⁻¹).

A continuous flow rate of 700 ml min⁻¹ and gentle aeration in the upper part of the water column were provided. The water inflow was located above the water surface in one of the corners of the aquaria. A window screened with 800 µm mesh during the day-light period allowed the exit of the remaining prey between feeding times. At night, water outlets were screened with 250 µm mesh to avoid prey and seahorses from leaving the aquaria and allowed water to circulate. Twice daily, wastes and faeces were siphoned, and dead seahorse removed and counted. The experiment was finished at day 30, when all survivors were counted, weighted and measured as reported by Lourie (2003).

2.2.4. Experiment 2: Starving Conditions.

Newborns from two batches (the same as in Experiment 1) were also maintained (5 juveniles L⁻¹) at 15, 18 and 21 °C. The experiment was carried out in 10 L rectangular aquaria (33 x 21 x 17 cm) similar to those described by Chamorro et al. (2010). Freshly released newborn were transferred to the aquaria and maintained deprived of food until death. The rearing system was set up with a constant water flow of 300 ml min⁻¹ and moderate aeration. Black upper covers were used in addition to black walls in the upper half of the aquaria sides. Mortalities were recorded twice daily throughout the experimental period.

2.2.5. Sampling and data analysis.

In Experiment 1, samples (n=10-15) of seahorses were taken at 0 and 30 DAR (days after release). Samples (n=10) for other purposes were also taken at 5 DAR (Exp. 1) and 15 DAR and the resulting weight data used for calculations of growth. Collected seahorses were anaesthetised with MS222 (0.1 g L⁻¹), washed with tap water, transferred individually to Petri dishes and photographed for standard length (SL). Then, the excess of water was removed and the seahorses pooled or individually weighted, depending of seahorse size, on a Sartorius microbalance MC210P (\pm 0.01 mg). Finally, seahorses of samples taken at days 15 and 30 DAR were transferred to their original aquaria. Estimated final survivals were corrected for sampling mortality.

SL was measured as head + trunk+ tail length (curved measurement), as reported by Lourie (2003b). Measurements were made on digital images using image processing software (NIS, Nikon). Calculations involving development, growth and temperature were performed according to the formulations described in Otterlei et al. (1999). Daily weight-specific growth rates (G; % day⁻¹) were calculated as:

$$G = 100 (e^g - 1) \quad (1)$$

where the instantaneous growth coefficient g is obtained by the following equation

$$g = (\ln W_2 - \ln W_1) / (t_2 - t_1) \quad (2)$$

where W_2 and W_1 are the average seahorse wet weights (mg) on days t_2 and t_1 , respectively.

The following third-order polynomial was fit to test the effect of temperature (T; °C) on weight-specific growth rates:

$$G = a + bT + cT^3 \quad (3)$$

where a , b and c are constants.

Growth and survival were analyzed applying three time indices: chronological (days), day-degrees (D°) and effective day-degrees (D°_{eff}) (Weltzien et al., 1999).

Progress in day-degrees (D°) was computed as:

$$D^{\circ} = \Delta t \cdot T \quad (4)$$

where Δt is developmental time in days and T is the temperature in °C.

Effective day-degrees (D_{eff}°) is an index of developmental progress based on a species-specific threshold temperature (T_0) at which development (growth in the present study) is theoretically arrested. D_{eff}° was calculated from Eq. (4) as:

$$D_{\text{eff}}^{\circ} = \Delta t \cdot T_{\text{eff}} = \Delta t \cdot (T - T_0) \quad (5)$$

where T_{eff} is the biologically effective temperature ($T_{\text{eff}} = T - T_0$). The 2-days adaptation of seahorses to experimental temperatures was taken into account in the calculation of D_{eff}° .

Seahorse growth was modelled using a generalized temperature-dependent growth model by pooling the data from the experimental temperatures. The model applied was a modified Gompertz equation described by Otterlei et al. (1999):

$$\ln W(t) = \ln W_0 - A + A \cdot K^{(1 - e^{-(a+b \cdot T) \cdot t})} \quad (6)$$

where W (mg) is the wet body mass at time t (days, D° or D_{eff}°), W_0 is the initial weight and K an expression of growth rate. Parameters A , a and b are constants and the linear temperature function $a+bT$ is α , the rate of exponential decay. Parameter K was estimated as:

$$K = \ln(\ln W_{\infty} - \ln W_0 + A) / A \quad (7)$$

where W_0 and W_{∞} are the initial and final wet body mass, respectively. W_0 and W_{∞} were fixed according to the data set (5.06 and 250 mg, respectively).

Parameters of the equation 6 were estimated by nonlinear estimation. Further details on the computation of data are provided in Otterlei et al. (1999).

The resulting equation 6 for effective-day degrees was converted to a unique third-order polynomial to test the effect of time on weight-specific growth regardless of temperature:

$$G = a + bt + ct^2 + dt^3 \quad (8)$$

where a , b , c and d are constants and t is time in effective day-degrees (D_{eff}°).

In starving larvae, mortality data (M ; %) were fit to the sigmoidal model:

$$M = a + ((b - a) / (1 + e^{-(t - c) / d})) \quad (9)$$

with a , b and d constants, t time (days, D° or D_{eff}°) and c time of 50% mortality (M_{50}).

Fulton's condition factor (K_F) was calculated as:

$$K_F = (W/SL^3) * 1000 \quad (10)$$

with W wet weight and SL standard length.

Analysis of variance (ANOVA) was applied to estimate effects of temperature on survivals and growth. Differences among treatments were tested using post-hoc LSD's multiple comparison test. The statistical analyses and calculations were performed using the software packages Statistica 8.0 (StatSoft) and IBM SPSS 15.0.

2.3. Results

2.3.1. Feeding juveniles

The relative percentage of clear brown juveniles throughout the experiment was directly related to temperature level, increasing notoriously at higher temperatures (0-5 % at 15°C, 70-80 % at 18°C and 95-100 % at 21°C). The swimming activity was also dependent on temperature level. Seahorses fed at 15 °C were scarcely active when compared to those raised at higher temperatures.

Table 1. Experiment 1: Summary of growth and survival in fed seahorses *Hippocampus guttulatus*. Initial wet body mass and standard length was 5.06 ± 1.00 mg and 15.3 ± 0.7 mm, respectively.

Temperature (°C)	SL Day 30 (mm)	Wet body mass Day 30 (mg)	Specific growth rate G (%)	Survival Day 30 (%)
15	21.5 ± 0.7	14.69 ± 3.63	3.60 ± 0.17	21.92 ± 2.36
18	33.0 ± 5.8	51.86 ± 22.08	7.90 ± 0.86	85.76 ± 0.41
21	41.2 ± 5.6	106.43 ± 30.02	10.65 ± 0.32	81.04 ± 0.20

A summary on the results achieved in the early development of the long-snouted seahorse *Hippocampus guttulatus* is provided in Table 1. The dependency of daily weight specific growth rate on temperature is expressed by the polynomial regression: $G = - 32.905 + 2.8079 T - 0.00166 T^3$ ($r^2 = 1$; $n = 6$). This function was used to estimate $T_0 = 13.1 \pm 0.9$ °C (95 % confidence interval). T_0 was used in the calculations of developmental time in D_{eff}^0 . The estimate of the optimal temperature (T_{max}) for G_{max} (11.5 %) in fed ad libitum juveniles was 23.4 ± 1.4 °C.

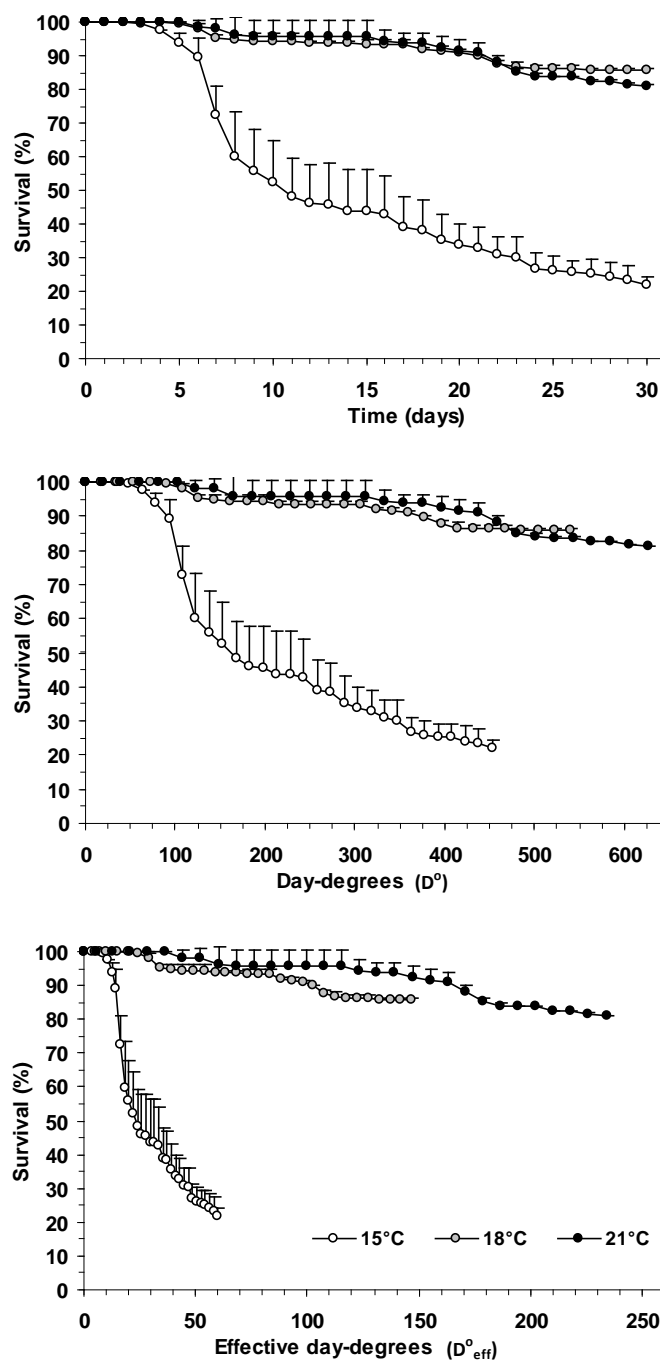

Figure 1. Survivals (%) in fed newborn seahorses *Hippocampus guttulatus* maintained at 15, 18 and 21 °C. Data are provided for chronological time (days), day-degrees (D°) and effective day-degrees (D°_{eff}).

The effect of temperature on seahorse survival related to three different time indices is shown in Figure 1. Survivals were temperature dependent during all the experimental period. Seahorses raised at 15 °C showed a progressive mortality from day 4 (63 D°; 10.6 D°_{eff}) onwards, especially between 5 and 8 DAR. On the contrary, mortalities at 18 and 21 °C started later (day 6) and were considerably reduced. As shown in Figure 1, differences in

survival patterns were even more evident when effective day-degrees were used as time index.

Significant differences (One-way ANOVA, $p < 0.0001$) were also encountered in mean final survivals at day 30 among experimental temperatures (LSD test; $p < 0.0001$; $15\text{ °C} < 21\text{ °C} < 18\text{ °C}$), with percentages of 21.1, 85.9 and 81.1 % at 15, 18 and 21 °C, respectively. In spite of this, a different pattern aroused when effective-day degrees was considered as time index. According to this index, the best performance in terms of survival at any level of D°_{eff} was achieved at 21 °C.

Mass body weight was dependent on age and temperature level. Final wet weights (14.7, 51.9 and 106.43 at 15, 18 and 21 °C, respectively) were significantly different (One-way ANOVA, $p = 0.040$; (LSD test; $15\text{ °C} = 18\text{ °C} < 21\text{ °C}$).

The shift in final wet body mass with temperature is described by the exponential function: $W = 0.127 e^{0.327 \text{ Temp}}$ ($r^2 = 0.944$; $n = 6$) (One-way ANOVA; $p < 0.001$). Increasing temperature from 15 to 18 and 21°C generated a 4 and 8-folds increase in final wet weight, respectively.

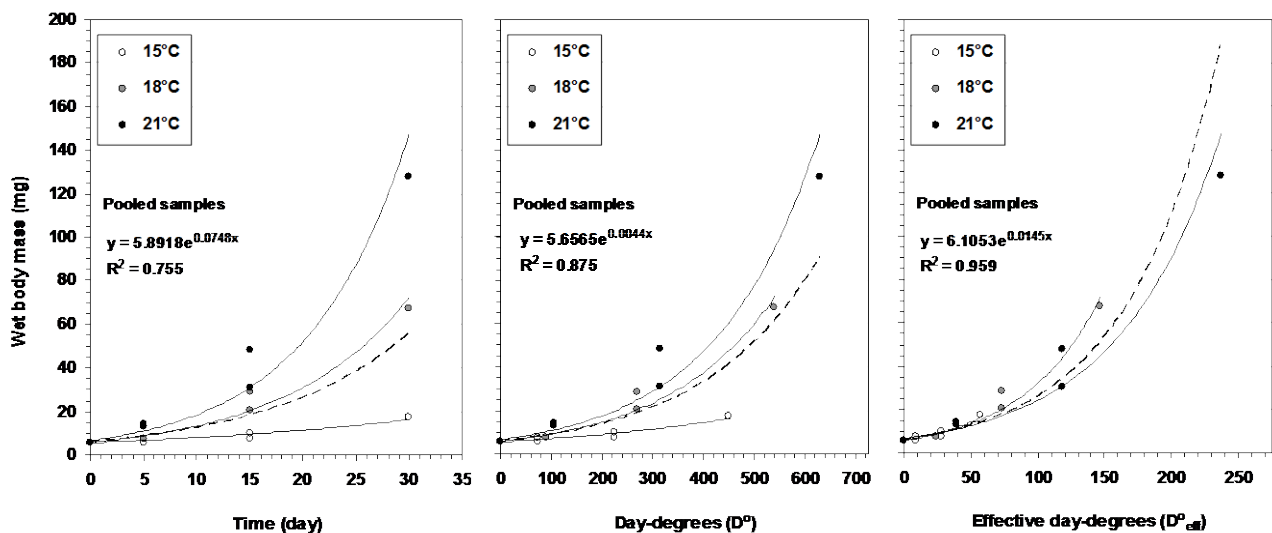

Figure 2. Wet body mass (mg) in fed newborn seahorses *Hippocampus guttulatus* maintained at 15, 18 and 21 °C. Data are provided for chronological time (days), day-degrees (D°) and effective day-degrees (D°_{eff}).

Wet body mass was modelled as a function of developmental scales (day, D° and D°_{eff}) and temperature for comparison of the different time indices (Figure 2). For each experimental temperature and independently of the scale used, the data fit reasonably well. However, fitting regardless of temperature was not good for D° and especially chronological

time. On the contrary, a significant fitting was achieved for D_{eff}° : $W = 6.1053 e^{0.0145 D_{\text{eff}}^{\circ}}$ ($r^2 = 0.959$; $n = 33$).

Table 2. Experiment 1: Growth parameter estimates by the modified Gompertz model (Equation 6) for the three time scales studied. The initial and final wet body mass (W_0 and W_{∞}) were fixed according to the data set (5.06 and 250 mg, respectively).

Time indices	Parameters			Regression		
	A	a	b	n	F	p
Days	1.241	- 0.12833	0.009840	33	4634.5	<0.0001
D°	1.290	- 0.00489	0.000414	33	3893.0	<0.0001
D_{eff}°	1.026	0.01322	-0.000151	33	4755.7	<0.0001

Modelling of seahorse wet body mass as a function of time and temperature according to the modification of the Gompertz model (Equation 6) conducted to the growth parameter estimates reported in Table 2. The resulting growth curve models for single temperatures between 14 and 26°C and the three time indices are depicted in Figure 3. D_{eff}° is only time index that allowed fitting of growth in a unique equation regardless of temperature. The resulting equation is expressed by the regression: $W = 7.409 - 0.0555 D_{\text{eff}}^{\circ} + 0.0037 D_{\text{eff}}^{\circ 2} - 0.000006 D_{\text{eff}}^{\circ 3}$ ($r^2 = 0.998$; $n = 108$). Predicted wet body mass at age agree with observed data.

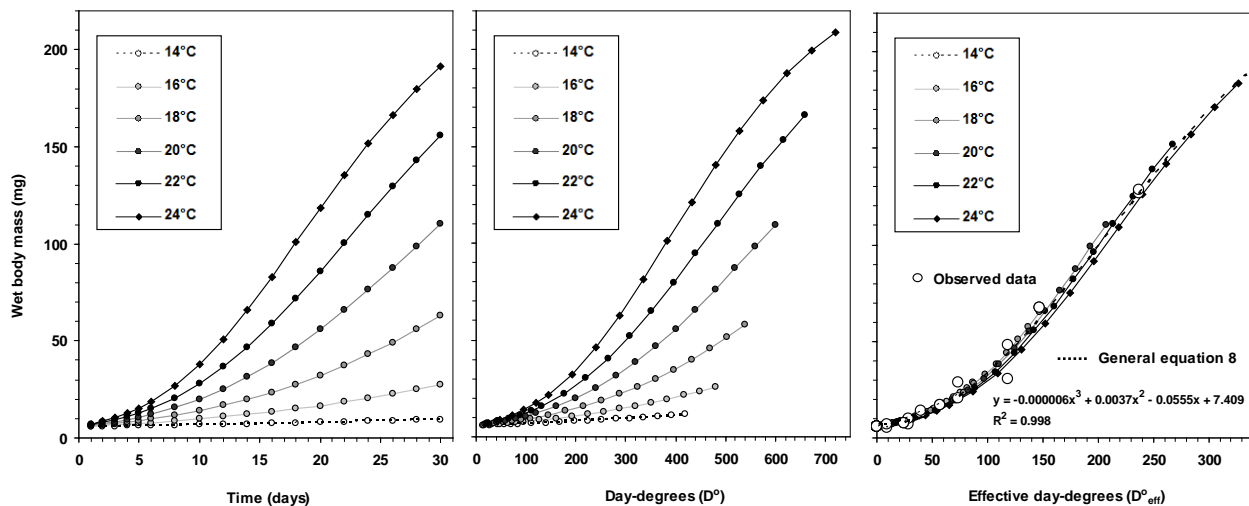

Figure 3. Estimated (from Equation 6) wet body mass (mg) in fed newborn seahorses *H. guttulatus* for temperatures from 14 to 24 °C. Data are provided for chronological time (days), day-degrees (D°) and effective day-degrees (D_{eff}°).

Fulton's K_F index decreased until day 5 post-birth, being similar among temperatures (1.184 ± 0.085 at 15 °C; 1.199 ± 0.077 at 18 °C; 1.178 ± 0.033 at 21 °C). K_F values were maintained until day 15 (1.143 ± 0.058 at 15 °C; 1.160 ± 0.008 at 18 °C; 1.055 ± 0.118 at

21°C) and increased at day 30 (1.460 ± 0.212 at 15 °C; 1.338 ± 0.029 at 18 °C; 1.380 ± 0.005 at 21 °C), reaching values similar to those in newborn (1.465 ± 0.038). No consistent patterns were observed due to temperature level.

2.3.2. Starving juveniles

During the first 48 h, the colour and swimming patterns of unfed juveniles were similar to those in fed seahorses at 15, 18 and 21 °C. At 15 °C, all juveniles showed a dark pigmentation and low swimming activity during the whole period of study. From 3 – 4 DAR, starving seahorses at 18 and 21°C displayed a progressive black colouration and a reduction of active swimming.

The dependency of daily weight specific growth rate on temperature is expressed by the polynomial regression: $G = -0.996 + 0.1402 T - 0.0061 T^2$ ($r^2 = 0.829$; $n = 6$). As for fed larvae, T_0 was estimated at 12.5 ± 0.9 °C (95 % confidence interval).

Mortalities in seahorses deprived of food started on day 3 at 15 °C and on day 4 at 18 and 21 °C whereas full mortality was observed on day 8 at 15 °C and days 7 - 8 at 18 and 21 °C (Figure 4). The time of M_{50} also varied with respect to temperature and was estimated to occur at days 5.6 ($100 D^0$, $16.7 D^0_{\text{eff}}$), 6.3 ($113 D^0$, $34.6 D^0_{\text{eff}}$) and 6.7 ($117 D^0$, $47.3 D^0_{\text{eff}}$) for 15, 18 and 21 °C, respectively. The width of the mortality period was inversely correlated to temperature.

At day 5, Fulton's K_F values in fed juveniles were lower than in newborn (1.46 ± 0.04) and inversely related to temperature level (1.16 ± 0.07 at 15 °C; 1.07 ± 0.02 at 18 °C; 1.01 ± 0.04 at 21 °C).

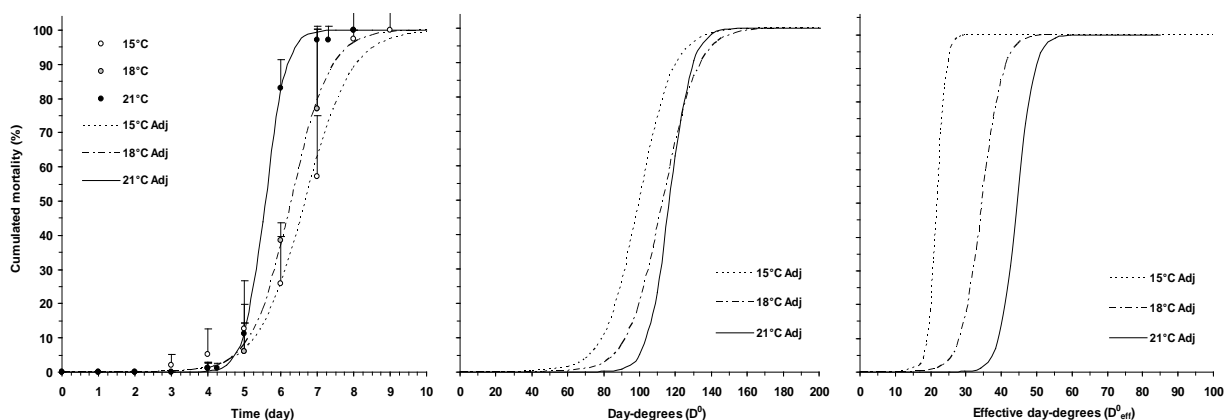

Figure 4. Cumulated mortalities (%) in starving newborn seahorses *Hippocampus guttulatus* maintained at 15, 18 and 21 °C. Data are provided for chronological time (days), day-degrees (D^0) and effective day-degrees (D^0_{eff}).

2.4. Discussion

Adverse conditions in both feeding and starving juveniles were shown at cool temperatures approaching T_o (13.1 ± 0.9 °C). The suboptimal status in those juveniles was characterised by high and faster mortalities, a decreasing swimming activity and a permanent dark colouration. Growth and survival in juveniles fed *ad libitum* at 15 °C were drastically reduced with respect to those grown at 18 and 21 °C. The early development of *ad libitum* fed juveniles was improved at temperatures closer to 21 °C or within the range of 18 – 21 °C. The calculated T_{max} (23.4 ± 1.4 °C) would be below the unknown upper temperature limit for the species as it is in agreement with the maximal water temperature (26 - 28 °C) recorded for the populations in Ria Formosa (Portugal) in summer (Falcão and Vale, 2003; Curtis and Vincent, 2005) and the temperature (24 – 25 °C) at which breeders are maintained in captivity in South Portugal (Faleiro et al., 2008). In the coast of Galicia (NW Spain), where our breeders were captured, the seawater temperatures of surface layers in the period 2009 - 2011 were <20 °C in summer and >10.5 °C in winter (Arbones et al., 2008; www.intecmar.org).

The resistance of juveniles to starvation (weight loss and mortality) was inversely dependent on temperature. Initially, unfed juveniles increased in length at the expenses of their endogenous reserves. The weight loss during the first 5 days in juveniles deprived of food at 15, 18 and 21 °C was 24, 30 and 34 %, respectively. These results agree with Blanco et al. (2011), who reported that the most important drop in weight and energy at 20 °C occurs during the first 24 hours of inanition. In the presence of food in excess, a slight increase in weight was observed at day 5 though specific growth rates increased notoriously afterwards. As shown in other fish larvae (Yúfera and Darias, 2007) and in seahorses (Sheng et al., 2007; Blanco et al., 2011a), a delay in the successful adaptation of seahorse newborn to prey capture or a low food availability was accompanied by a progressive drop in weight and a decrease in the energetic status.

Positive buoyancy was observed in weakened starving juveniles, which progressively accumulated near the water surface and developed swimbladder hyperinflation. Changes in the biochemical content of juveniles have implications in specific gravity and buoyancy. The loss in water content and the depletion of protein in starving fish larvae have been considered the cause of the increase in buoyancy (decrease in specific gravity) in starving fish larvae (Blaxter and Ehrlich, 1974). In our study, the water content in fed juveniles (84 %; Figures 5 and 6) was independent of the temperature level and remained stable during the first month of

life. On the contrary, the water content in unfed juveniles was very variable (about 80 %) and lower than in fed seahorses, although the relationship between wet and dry weight in starving juveniles was not significant. Protein and mainly lipids are the main fuel source for the first 24 hours of live in starving juveniles whereas protein remains as the almost unique energy source available in unfed juveniles until dead (Blanco et al., 2011a). Consequently, it is feasible that the increase in buoyancy of starving seahorses be due to protein depletion rather than to a relative lose of water.

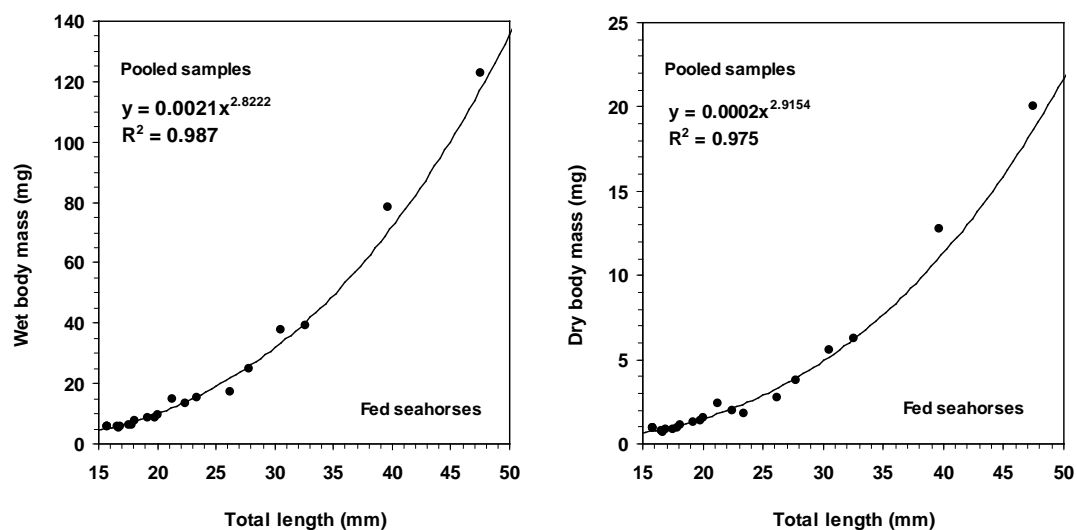

Figure 5. Relationship between total length (mm) and body mass (mg) in fed newborn seahorses *Hippocampus guttulatus*. Pooled data for 15, 18 and 21 °C.

Conversely to most species of fish, newborn seahorses do not have yolk sac, and are fully developed (eyes fully developed, functional jaw, active swimming) and ready for exogenous feeding (functional digestive system). In lecithotrophic fish larvae the initial growth is supported by endogenous feeding from yolk reserves (Balon, 1986). Tolerance to starvation of these larvae would depend on the amount of yolk and to the onset of exogenous feeding on natural prey (Dou et al., 2005). In seahorses, which are viviparous, it would be expected that resistance to starvation be shorter than in yolk-sac larvae. Surprisingly, our results and those of Sheng et al. (2007) in *H. trimaculatus* and *H. kuda* do not support that assumption. Sheng et al. (2007) pointed out that seahorses have a certain tolerance to starvation as juveniles were able to recover in growth if starved for less than 24 h but did not swim or ingest food when starved for more than 72 h. From the data in Sheng et al. (2007), we calculated that M_{50} in both seahorse species would occur on days 4.5 – 5 of age at 23–25 °C. Taking into account the differences in temperature levels, M_{50} in starving juveniles of *H. trimaculatus*, *H. kuda* and *H. guttulatus* were reached at similar times. In the former two

species, M_{50} and the point-of-no-return (PNR), which is the time when starving juveniles could not feed anymore (Blaxter and Ehrlich, 1974), would be reached simultaneously.

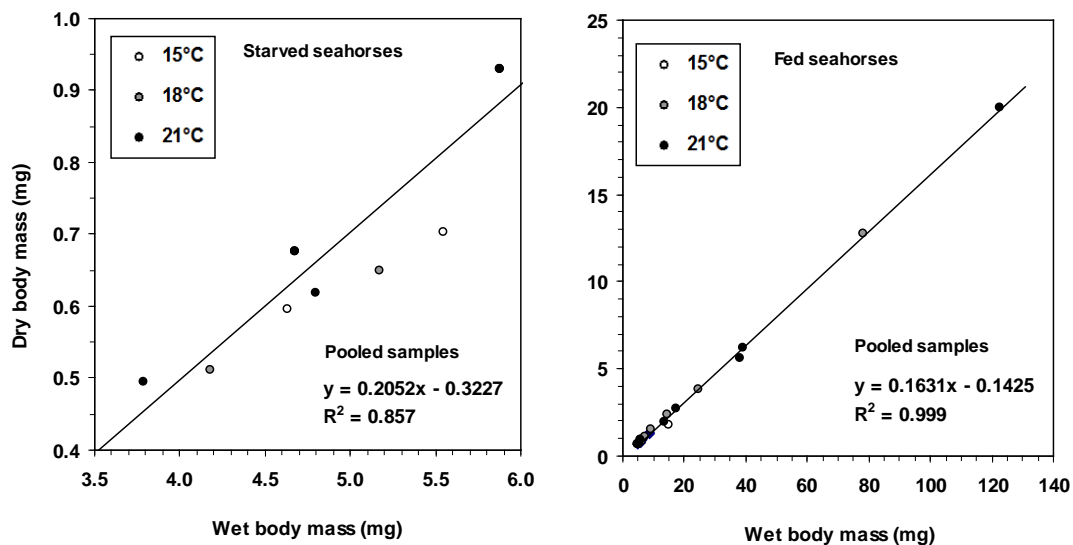

Figure 6. Relationship between wet and dry body mass (mg) in fed and starved newborn seahorses *Hippocampus guttulatus*. Pooled data for 15, 18 and 21 °C.

Fulton's condition factor has been widely employed to analyse fish condition. However, based on their own data and other studies, Neilson et al. (1986) pointed out that K_F would be a valid condition criterion in later stages of development and that the index does not adequately describe the condition of developmental stages in fish at the onset of exogenous feeding. They also suggested that buoyancy and the ability to avoid predation are better indicators of larvae condition. In our study, however, K_F -values until 5 DAR were consistent with the data on survival, growth and behaviour, both in fed and starved seahorses. K_F -values in starving juvenile were inversely related to temperature and lower in juveniles fed in excess for 5 days than in newborn. A progressive recovery in seahorse condition occurred from day 1, independently of temperature. At day 30, K_F approached to values of newborn. Our findings suggest that the first days are decisive in the further development and condition status of *H. guttulatus* juveniles and that energetic demand must be fulfilled as early as possible by means of a satisfactory food supply and adequate levels in environmental factors (i.e. temperature).

To what extent the results achieved can be extrapolated to nature and which are their ecological implications? The populations of *H. guttulatus* maintain gene flow within regions up to several hundreds of km between populations but a high level of genetic differentiation occurs between regions across the entire geographic range of the species (Woodall, 2009).

Therefore, it is feasible that populations would be adapted to different habitats and environmental conditions. Light regimes and temperature in Areas 1 - 3 differ substantially and it is very likely that some biological characteristics of the species do vary accordingly. For example, the duration of the reproductive season in the Ria Formosa (Portugal) Curtis (2007) and southern Spain (Reina-Hervás 1989) (Area 1), is twice as long as in Arcachon (France) (Boisseau 1967) (Area 3). Curtis (2007) suggested that among-population differences in the duration of the breeding season may be attributable to differences in photoperiod and temperature, the factors that control the maturation of seahorse females (Planas et al., 2010b). Unfortunately, knowledge on biological aspects of the early stages of *H. guttulatus* in different areas of its geographical distribution is very scarce (Boisseau, 1967; Pérez-Ruzafa et al., 2004; Curtis, 2007; Curtis and Vincent, 2006).

Environmental factors, mainly temperature, are decisive in the early development of fish, and have a great impact on primary and secondary production and consequently on growth, survival and feeding of juveniles (Blaxter, 1991). In spite of a possible adaptation of *H. guttulatus* populations to local environmental conditions, the advantages of temperatures in the range 18-21 °C are obvious. Hence, survival and growth in populations of Areas 1 and 2 would be drastically enhanced with respect to Area 3. Adult *H. guttulatus* inhabit and breed in shallow waters, generally rich in food resources. The extension of the breeding season over the year coincides with the warmer period of the year, when primary and secondary production is maximal (Sprung, 1994, in Curtis, 2007; Arbones et al., 2008; Gago et al., 2011). Newborn seahorses are pelagic during at least one month and feed on zooplankton. It has been reported in other fish species the dependency of larval survival on prey availability. In cod, for example, Galloway et al. (1998) proposed that survival is dependent on the interaction between zooplankton density and temperature, and Sundby (2000) suggested a link between copepod biomass, surface temperature and larval survival. At cooler temperatures (Area 3) seahorse juveniles may be better able to withstand starvation and also benefit by delaying the M_{50} , as pointed out in other fishes (Houde, 1989; Jobling, 1997; Laurel et al., 2008).

We advocate that newborn in Areas 1 and 2 would take profit of higher temperatures, a rich food supply and longer breeding periods (April-October) (Reina-Hervás, 1989; Curtis, 2007). On the contrary, newborn in Area 3 would grow at temperatures approaching T_0 , with lower food supply and shorter reproductive seasons (May-September) (Boisseau, 1967). The

results achieved in our study on survival and growth rates at different temperatures, the estimated threshold temperature T_0 , the estimated optimal temperature T_{max} for G_{max} , the known effect of photoperiod and temperature level on females maturation (Planas et al., 2010b), and the information available on the duration and extension of the breeding season in different regions of the full geographic distribution area of the species (Boisseau, 1967; Reina-Hervás, 1989; Curtis and Vincent, 2006; Planas et al., 2010a) would at least partially explain the current Northern limit of *H. guttulatus*.

Conservation efforts in the seahorse *H. guttulatus* include the research on the production of juveniles in captivity. Our results are of practical application to the rearing of this species. High survivals and especially fast growth rates would be reached at 21 °C. At this temperature, the risk of the potential development of infectious diseases increases and safety cultures could be carried out at lower temperatures, such as 19 - 20 °C. Apart of our laboratory (in Area 2), rearing attempts have been made in Portugal at 21.4 ± 0.5 °C with 20 % survival at day 30 (Palma et al., 2011). In those rearing, newborn were released by breeders captured in the Ria Formosa (Area 1), with maximal summer temperatures of about 28 °C (Curtis and Vincent, 2005).

Rates of ontogeny and growth in larval fishes respond similarly to environmental fluctuations (Fuiman et al., 1998) and the major extrinsic factors affecting ontogenetic rate are temperature and, to a lesser extent, salinity. Chronological time (age) is not a temperature-independent index of development, and thus other temperature-independent scales of measuring ontogenetic advancement, growth and catabolism have been searched in the last decades to describe physiological and anatomical features in embryos and early larval stages of poikilotherms (see review of Kamler, 2002) (Fuiman et al., 1998; Kamler, 2002). Day degrees (D°), physiological day degrees (PD°) (Huisman, 1974) and effective day-degrees (D°_{eff}) (Kamler, 1992) have been assayed as models for the quantification of the relationship between ontogenetic rate and temperature. In fish, those time scales have been applied mostly to embryogenesis and early development of yolk-sac larvae. However, the goal of temperature independence has been only achieved by D°_{eff} (Kamler, 1992; Kamler et al., 1994; Chambers and Leggett, 1992; Verreth, 1994; Weltzien et al., 1999; Cunha and Planas, 1997) and their use has been recommended (Kamler, 2002).

To our knowledge, this is the first study assessing temperature independency of several age scales in the early developmental stages of a viviparous fish, both under feeding

and starving conditions. We demonstrated, within a viable temperature range, the temperature-dependency of PD° and the suitability of D°_{eff} as a temperature-independent scale to quantify growth in the early development of feeding *H. guttulatus* juveniles. Weight-specific growth with development, expressed in D°_{eff} , could be estimated from a unique third-order polynomial model (Equation 8). Therefore, our results support the use of the D°_{eff} approach, previously applied to describe ontogenetic development in other fish species, to growth, not only in lecithotrophic larvae (Weltzien et al., 1999) but in viviparous newborn lacking yolk-sac.

By contrast to feeding juveniles, we also demonstrated the temperature-dependency of the scales assayed in newborn deprived of food. Initially, this unexpected finding is probably due to the absence of yolk reserves in newborn and to metabolic and physiological effects of the different temperature levels in starving seahorses. In lecithotrophic larvae, such as turbot *Scophthalmus maximus*, fatty acids catabolism is independent of the temperature level when development is expressed in D°_{eff} (Cunha & Planas, 1997), with most of these catabolic resources originating from yolk reserves. In the absence of yolk-sac, however, the energy demands would be based solely on a conservative mobilization of endogenous reserves in tissues, and also on a decreased swimming activity (Fukuhara, 1987, 1990; Skiftesvik, 1992). In yolk-sac larvae, inconsistent changes occur in the biochemical composition under starving conditions (Ehrlich, 1974; Cunha et al., 2003) and different temperatures result in different developmental sequences of morphological characters and behavioural patterns (Fukuhara, 1990). In contrast to fed seahorses, we observed changes in buoyancy and, though the biochemical composition was not analysed, incoherent results were achieved in water content of starving juveniles. Starvation would have temperature-dependent effects conducting to different levels of disruption in the general metabolic, physiologic and energetic status, as reported in other fish larvae (O'Connell, 1976; Theilacker, 1978; Yúfera et al, 1993). Those changes would not fulfil the law of thermal summation, according to which a linear correlation exists between developmental rate and temperature, and thus, the progress in development under starving conditions would not be efficiently described by D°_{eff} .

To what extent the adaptation of *H. guttulatus* populations to the different geographic regions would corroborate our hypothesis is uncertain and must be verified in the future from new data in nature and in mesocosm.

CHAPTER 3

**Mouth growth and prey selection in juveniles of the European
long-snouted seahorse *Hippocampus guttulatus***

Mouth growth and prey selection in juveniles of the European long-snouted seahorse *Hippocampus guttulatus*

ABSTRACT

Mouth morphology in seahorses (*Hippocampus* spp.) is very special in contrast to other fish larvae and adults. Seahorses are ambush predators that swallow the prey through their tubular snout, which might determine special feeding behavior and changes in prey preference. In order to better understand mouth growth and its effect on prey preference by juveniles of the seahorse *Hippocampus guttulatus*, experimental assays were carried out by feeding juveniles (0 – 30 DAR – Days after male's pouch release-) on a mixture of the live prey most commonly used in the rearing of marine fish larvae: rotifers (*Brachionus plicatilis*), *Artemia* nauplii and copepods (*Acartia tonsa*),

Mouth development in juveniles was accomplished by growth of upper and lower jaws, which were linearly correlated with juvenile length, whereas width (MW) and height (MH) mouth grew exponentially with respect to juvenile size. In addition, MW was found to be correlated to MH so that the transversal section of the mouth increased linearly with juvenile age and length. Gut content analyses and the results of the Ivlev selectivity index demonstrated a systematical rejection of rotifers by juveniles during the whole experimental period and a clear preference for copepods until 15 DAR and for *Artemia* nauplii afterwards. The results also suggest that juveniles are able to ingest prey much larger than those provided as the limiting factor in prey ingestion was not mouth width, as for many marine fish larvae, but mouth area. From the overall results achieved, a tentative feeding schedule is proposed to successfully feed *H. guttulatus* juveniles on copepods and *Artemia* nauplii from 0 to 30 DAR.

3.1. Introduction

Seahorses, *Hippocampus* spp., are highly unusual marine fishes (Wilson and Orr, 2011) that have a unique body morphology, bony plates in substitution of scales, a prehensile tail able to grasp and hold objects, a curvaceous trunk that provides them vertical swimming, a bent head horse-like shaped, large chameleonic eyes that move independently, and an elongated tubular snout with a small terminal mouth (Bergert and Wainwright, 1997; Koldewey and Martin-Smith, 2010; Lourie et al., 1999; Porter et al., 2013; Van Wassenbergh et al., 2011). Their morphological peculiarities as well as the traditional Chinese Medicine trade followed by habitat destruction and by-catch (Vincent, 1996) are the main threats seahorses have to face. Therefore, all the seahorse species are in the Red List of Threatened Species (IUCN, 2013) and are listed in CITES (CITES, 2002) and have become of main interest for marine fish aquaculture in the last decades (Koldewey and Martin-Smith 2010, Olivotto et al., 2011) to avoid the pressure on wild seahorse populations (Olivier 2003).

The establishment of a successful feeding schedule has been a main focus in seahorse rearing studies (Correa et al., 1989; Lockyear et al., 1997; Olivotto et al., 2008; Payne and Rippingale, 2000; Pham and Lin, 2013; Woods, 2000a). The traditional feeding scheme is commonly based on the use of *Artemia* nauplii, the rotifer *Brachionus plicatilis* and, less frequently, copepods. However, a successful feeding schedule has been barely achieved for first feeding and juvenile stages in seahorses (Olivotto et al., 2011).

Seahorse feeding relies on their capacity to capture live prey by swallowing them through the tubular snout to a stomachless digestive tract. Seahorses are visual predators that ambush on their prey (Felício et al., 2006; James and Heck Jr, 1994) and strike on them while keeping visual focus on the selected prey-item (Roos et al., 2010). However, it is well known that prey selection by marine fish larvae and juveniles strongly depend on the size of both fish and prey (Cunha and Planas, 1999).

Prey contrast, shape and mobility, as well as visual acuity, play an important role in the detection and capture of prey (Shaw et al., 2003; Souza-Santos et al., 2013). The relationship between predator mouth size and the prey size has been considered one of the key factors in the selection of prey (Cunha and Planas, 1999). The most commonly used preys in fish larviculture are the brine-shrimp *Artemia* spp, the rotifer *Brachionus* spp, and different species of copepods. Particularly, calanoid copepods are highly suitable prey for feeding marine fish larvae since they are planktonic and offer a wide size range (Olivotto et al., 2011).

The availability of adequate prey during the early developmental stages of fish has great impact on growth and survival (Cunha and Planas, 1999). Generally, the optimal prey size in many marine fish species is mainly determined by prey width (Cunha and Planas, 1999; Johnson et al., 2012) although prey-evasive behavior, prey availability, and predator capture efficiency are other maximum size-limiting factors. Thus, optimal prey size and feeding preferences relationship should be assessed for a better understanding of the feeding behavior in marine fish and the establishment of an efficient feeding scheme in the rearing (Scharf et al., 2000).

Prey selectivity has been already studied in some seahorse species such as *Hippocampus subelongatus*, *H. trimaculatus*, *H. kuda* and *H. reidi* (Celino et al., 2012; Payne and Rippingale, 2000; Sheng et al., 2006; Souza-Santos et al., 2013). However, feeding preferences in young long-snouted seahorses *Hippocampus guttulatus* have not been described. Accordingly, the aim of the present work was (i) to determine the relationship between seahorse mouth biometrics and prey selectivity in *H. guttulatus* juveniles submitted to different prey (*Brachionus plicatillis*, *Artemia* spp, and *Acartia tonsa*) and (ii) to establish an optimal prey size for the early rearing of the species.

3.2. Materials and methods

3.2.1. Seahorse culture

Wild adults *Hippocampus guttulatus* were collected by scuba diving from winter to summer in 2010 at several locations of the Galician coast (NW Spain) and transported to the rearing facilities at the IIM (CSIC) in Vigo (Spain). After a gradually acclimatization to aquaria temperature for 3-5 hours, captured seahorses were weighed and tagged using nylon collars with a unique code for individual identification and maintained as previously described (Planas et al., 2008b) under controlled temperature and photoperiod regimes (Planas et al., 2010a, 2013).

Newborn seahorses from two different batches were released in summer 2012 and summer 2013 and used in the present study. The juveniles were reared under standardized conditions of temperature, tank type, aeration and photoperiod and feeding (Planas et al., 2012; Blanco, unpublished data). PseudoKreisel aquaria were used in the rearing of seahorse juveniles in a seawater semi-opened recirculating system with strong aeration under a natural

photoperiod of 16L:8D (Light: Dark) and at 19°C (Planas et al., 2012). Feeding consisted of a first dose of *Artemia* nauplii (1 nauplii ml⁻¹) at 09.00 and a second dose of *Acartia tonsa* (adult and copepodites, 0.6 copepod ml⁻¹) at 15.00 from 0 to 10 DAR (Days after male's pouch release). From 11 DAR until the end of the experiment (30 DAR), seahorse juveniles were fed on four daily doses of *Artemia* nauplii and metanauplii (1:1) at 09.00, 12.00, 15.00 and 18.00 h (1 *Artemia* ml⁻¹).

3.2.2. Prey culture

Three prey types were used in the present study: the rotifer *Brachionus plicatillis*, the brine shrimp *Artemia*, and the calanoid *Acartia tonsa*. Rotifers were cultivated in 20 L tanks at 23 °C and fed on the microalgae *I. galbana* (6x10⁶ cells ml⁻¹), with daily sea-water and food renewals (20% tank volume). *Artemia* cysts were incubated at 28 °C for 24h and the freshly hatched nauplii transferred to 5 L buckets (100 *Artemia* ml⁻¹). *Artemia* metanauplii were obtained from nauplii enriched for 24 h at 26 °C on a mixture of the microalgae *Isochysis galbana* (10⁷ cells ml⁻¹) and *Phaeodactylum tricornutum* (1.6 10⁷ cells ml⁻¹). Calanoid copepods *Acartia tonsa* were cultivated on mixtures of the microalgae *I. galbana* (10⁷ cells ml⁻¹) and *Rhodomonas lens* (16⁷ cells ml⁻¹) at low densities (up to 1 adult copepod ml⁻¹) in 250-500 L tanks. Siphoning, feeding and water exchange were applied every other day.

Prior to their use, the prey were washed and sieved on different mesh sizes depending on the species (50 µm for rotifers, 125 µm for *Artemia* nauplii, and 180 µm for copepods), and then counted before feeding the seahorse juveniles. Prey samples were taken, freeze-dried (Ilshin Lab Co., Ltd.) and weighted using a Sartorius microbalance MC210P (± 0.01 mg) for dry weight (DW). In addition, prey samples were taken and randomly photographed for total length (TL) and width (W) measurements (n=30). Prey section surface (S) was estimated considering the prey as a cylinder and measuring the area of a transversal plane at the widest part of the prey body (appendices were not considered).

3.2.3. Experimental procedures

Seahorse juveniles used in the experiments were taken directly from the general rearing tanks. Changes with age in mouth biometrics of seahorse juveniles were analyzed. For that, juveniles were randomly sampled at different ages (0, 2, 5, 10, 15, 20, 40, 50 and 60 DAR - days after release-), anesthetized with MS-222, photographed for standard length (SL, mm), and weighted (WW) by using a Sartorius microbalance MC210P (± 0.01 mg) after water excess removal. Then, an extra dose of MS-222 was supplied to euthanate juveniles to

perform mouth morphometric measurements under the stereomicroscope (Nikon). Mouth opening of anesthetized juveniles was forced by using stainless forceps and needles. Opened mouths were photographed laterally on the left side and frontally (Figure 1). Then, upper jaw (UJ), lower jaw (LJ), mouth height (MH) and mouth width (MW) were measured from the photographs by using an image processing software (NIS Elements, Nikon). Mouth area (MA) ($\pi * MH/2 * MW/2$) was estimated considering the total mouth gape as an ellipsoid, whose axes were determined by MH and MW.

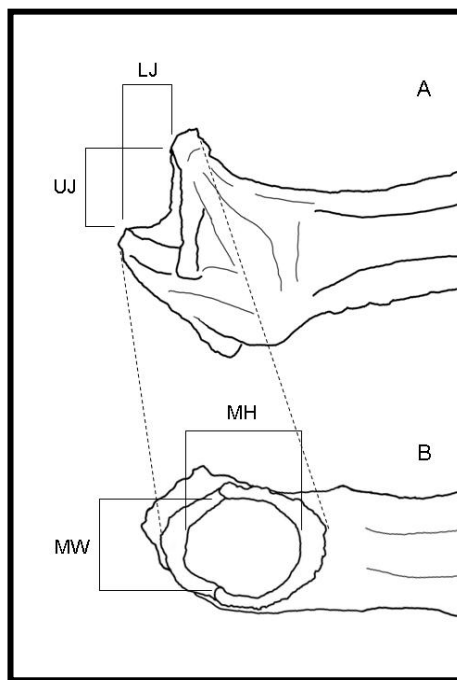

Figure 1. Mouth measurements of cultured seahorses. A) Lateral view: lower jaw (LJ) and upper jaw (UJ). B) Mouth gape: mouth width (MW) and mouth height (MH).

Prey selection in early developmental stages was studied in seahorse juveniles at 0, 3, 6, 10, 15, and 30 DAR. Three different preys were used in the experiment: *Brachionus plicatillis*, *Artemia* sp., and *Acartia tonsa* (Table 1). The evening before the experimental day, 20 - 40 seahorses were transferred from the reservoir rearing aquaria to 30 L pseudoKreisel aquaria and kept fasting overnight to ensure full gut emptiness. At the experimental day, remaining feces and detritus were removed before the start of the experiment. At the start of the experiment, a fixed amount of prey (20000 μg DW of total prey biomass; prey ratio 1:1:1) was added to each experimental aquarium, corresponding to 1.92 rotifers ml^{-1} , 0.38 nauplii ml^{-1} and 0.40 copepods ml^{-1} , respectively. After an experimental feeding period of 60 minutes, the juveniles were removed from the aquaria, anesthetized with MS-222 and stored in formalin 4% for further gut content analysis. Sampled seahorses were photographed for standard length (SL, mm), and subsequently the water excess was removed for wet weight

determination (WW) by using a Sartorius microbalance MC210P (± 0.01 mg). Biometric measurements were made from digital images.

Gut content analyses in juveniles were performed both macroscopically and microscopically. For that, seahorses were dissected under a stereomicroscope (Nikon) by using stainless forceps, scalpels and needles. Then, the full digestive tract was removed and accurately opened longitudinally to release gut content, which was photographed for further measurements. Subsequently, the type and number of copepods and *Artemia* nauplii were recorded macroscopically. Gut contents were further analyzed under a microscope (Nikon) for rotifers (mastax) counting (Cunha and Planas, 1995). In addition, prey measurements in gut contents were also determined from digital photographs taken under a stereomicroscope by using an image analyzing software (NIS Elements, Nikon).

Mean width, total length and section (pW, pTL and pS) of the experimental prey were determined by analyzing photographs from both prey offered to the juveniles and gut content at different ages (Table 1). Average mean size (width, total length and section area) of ingested prey was calculated considering the relative contribution of each prey type in the gut and the corresponding prey size.

For each analyzed gut, the relative and absolute content in both number and biomass were calculated for all prey. Feeding incidence at different ages was calculated as the percentage of juveniles containing at least one prey item in the gut. Prey preference was analyzed using Ivlev's selectivity index (E) (Ivlev, 1961) for both prey number and prey DW:

$$E = (pG - pA) / (pG + pA)$$

where pG is the relative content of a given prey in the gut and pA the relative content of the same prey type in the aquaria. The index value ranges from -1 to +1. Positive values show preference for the prey whereas negatives values show no preference.

3.2.4. Sampling and data analysis.

One-way repeated measures ANOVA was applied to investigate prey preference considering both total prey items and total prey biomass, considering seahorse wet weight as main effect. Bonferroni post-hoc test was used for statistical differences ($\alpha = 0.05$). Greenhouse-Geisser correction was applied when sphericity assumption was not accomplished.

Table 1. Dry weight and biometrics of experimental prey (supplied and ingested) in the early the rearing of the long-snouted seahorse *Hippocampus guttulatus*.

	Dry Weight (μg)	Total Length (μm)			Width (μm)			Section (mm^2)		
		Mean \pm SD	Max	Min	Mean \pm SD	Max	Min	Mean \pm SD	Max	Min
Ingested										
<i>Acartia tonsa</i>	4.17 \pm 0.12	729 \pm 106	978	506	240 \pm 37	322	182	0.046 \pm 0.014	0.082	0.026
<i>Artemia nauplii</i>	2.05 \pm 0.49	595 \pm 63	714	472	173 \pm 20	210	126	0.024 \pm 0.005	0.035	0.013
<i>Brachionus plicatilis</i>	0.45 \pm 0.12	249 \pm 55	359	168	145 \pm 28	192	85	0.017 \pm 0.006	0.029	0.006
Supplied										
<i>Acartia tonsa</i>	1.67 \pm 0.01	614 \pm 140	896	110	218 \pm 53	305	74	0.040 \pm 0.017	0.073	0.004
<i>Artemia nauplii</i>	1.72 \pm 0.04	576 \pm 82	697	450	196 \pm 20	244	160	0.030 \pm 0.006	0.047	0.020
<i>Brachionus plicatilis</i>	0.35 \pm 0.03	222 \pm 37	303	168	136 \pm 26	180	85	0.015 \pm 0.006	0.025	0.006

3.3. Results

Weight and size of the three preys used in the experiment are provided in Table 1. For data on prey in gut contents, mean values are provided for each prey as the average size of the prey for the whole experiment (not statistically differences for different juvenile ages).

Feeding incidence was higher than 85% (87-100%) at all experimental ages except for first feeding juveniles (77% at 0 DAR) (Figure 2). Most feeding juveniles preferred to feed on copepods and *Artemia* nauplii, whereas rotifers were exceptionally observed in the guts, being a negligible part of the whole gut content. At 0 DAR, 35% of newborn fed on nauplii + copepods, 27% solely on *Artemia* nauplii and 12% on rotifers + nauplii + copepods. Afterwards, none of the juveniles fed solely on nauplii, and the percentage of juveniles feeding on mixtures of nauplii+ copepods or rotifer + nauplii + copepods was very high, especially in the former.

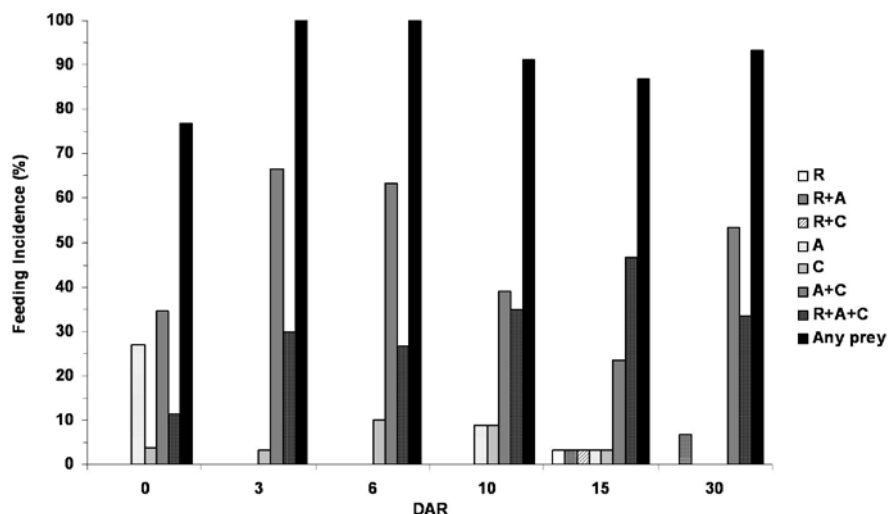

Figure 2. Feeding incidence in seahorse juveniles at different ages (DAR) fed on a mixture of rotifers (R), *Artemia* nauplii (A) and copepods (C). Data are provided for single prey and for all possible combinations.

Mean prey items and dry weight biomass in gut contents progressively increased from 0 DAR (9 prey; 27 μg DW) to 30 DAR (80 prey; 197 μg DW), with a slight decrease at 10 DAR (34 prey; 122 μg DW) (Figure 3). The rotifer *B. plicatillis* was exceptionally ingested by seahorse juveniles at all experimental stages (max: 2 rotifers gut^{-1} at 15 DAR) (Figure 3). Even that *Artemia* nauplii notably contributed to total gut content, *Acartia tonsa* was the dominant prey (items and biomass) until 15 DAR, when the content in copepods and nauplii were similar in number (31 copepods; 26 nauplii) but still higher in the former (110 μg DW copepods; 63 μg DW nauplii). In 30 DAR juveniles, the relative contribution of *A tonsa* was

reduced (17 copepods; 71 μg DW) whereas *Artemia* nauplii became dominant in the guts (61 nauplii; 125 μg DW).

Considering the total number of prey items ingested by juveniles at different ages (Significant age – prey interaction effect; $F_{(7.83, 203.60)} = 11.34$; $p < 0.001$; $\eta = 0.30$; Greenhouse-Geisser corrected) (Figures 3A and 3B), statistical differences between prey types were not significant ($p > 0.05$) in newborn (9.50 ± 0.6 prey items gut⁻¹). In spite of this, the content in rotifers (0.35 \pm 0.1) was much smaller than those in *Artemia* (5.10 \pm 0.3) and copepods (4.05 \pm 0.5). From 0 to 10 DAR, copepods were the mostly ingested prey ($p < 0.01$) but no significant differences were found between copepods and nauplii in 15 DAR juveniles. At 30 DAR, the content in *Artemia* nauplii was statistically higher ($p < 0.01$) than that for copepods (67.15 ± 22.81 and 17.08 ± 13.03 , respectively).

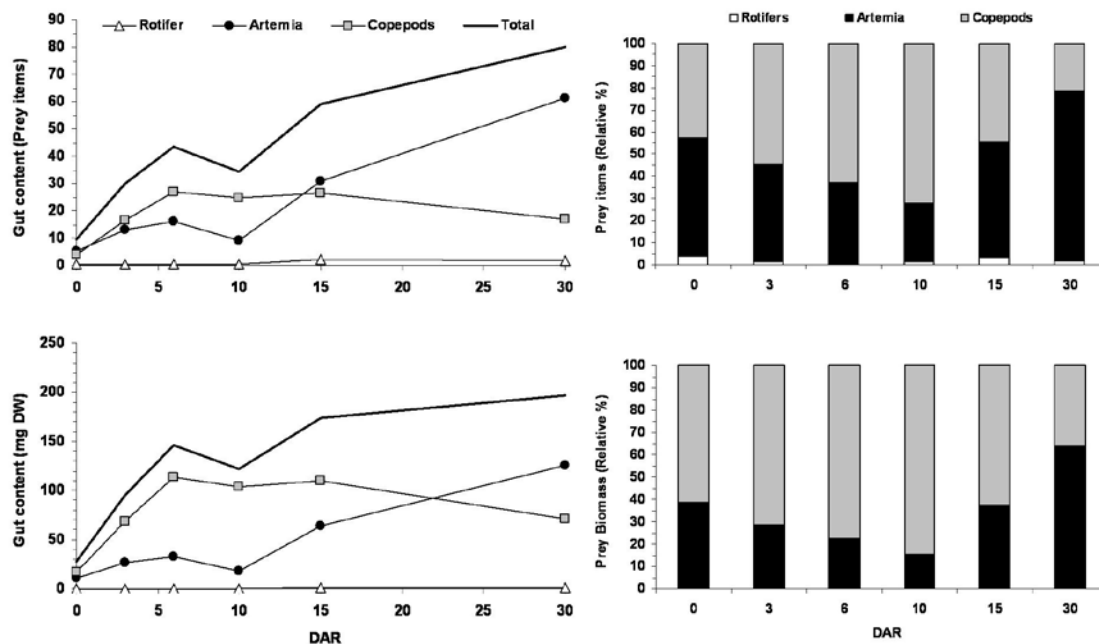

Figure 3. Gut contents (prey items and dry weight) in juveniles of *H. guttulatus* fed on mixtures of copepods, *Artemia* nauplii and rotifers.

Similar results were achieved from the data on gut content biomass (Significant age – prey interaction effect; $F_{(6.42, 167.04)} = 6.99$; $p < 0.001$; $\eta = 0.21$; Greenhouse-Geisser corrected) (Figures 3C and 3D). From 3 to 15 DAR, the gut content in copepod biomass was higher than in *Artemia* nauplii ($p < 0.05$). At 30 DAR, the contribution of *Artemia* in the gut biomass was higher than for copepods; however, differences were not significant ($p > 0.05$).

Ivlev selectivity index applied to both prey number and biomass (Figure 4) confirmed the above results, particularly with respect to (i) the clear rejection of rotifers by juveniles

during the whole experimental period, (ii) the preference for copepods over nauplii until 15 DAR, and (iii) the increase in the preference of *Artemia* nauplii from 15 DAR onwards.

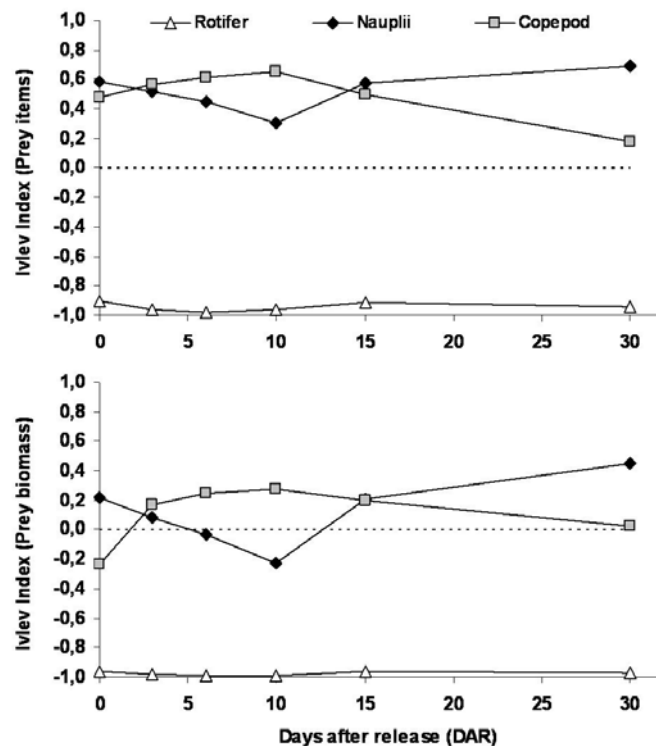

Figure 4. Ivlev's index of electivity (prey items and biomass) for copepods, *Artemia* nauplii and rotifers in the feeding of seahorse juveniles until 30DAR.

Biometrics performed on prey from gut contents revealed the following average sizes in ingested prey (Table 1): 249 μm TL and 145 μm W in rotifers, 595 μm TL and 173 μm W in *Artemia* and 729 μm TL and 240 μm W in *A. tonsa*. Those results, when compared to the average size of the three preys supplied in the experiment, indicate that juveniles actively selected large items within the size range offered, especially in copepods.

Growth in length of juveniles was linearly correlated to age (Figure 5A). Mouth biometrics and their relationship with seahorse development are shown in Table 2 and Figure 5. Mouth growth was accomplished by growth of upper and lower jaws, which were linearly correlated with juvenile length (Figures 5B and 5C), as it was the sum of both jaws (Figure 5D). Accordingly, mouth width (MW) and height (MH) were also correlated (Figure 5E) so that mouth section increased linearly with juvenile age and length (Figures 5F and 5G). However, MW and MH grew exponentially with respect to juvenile size (Figure 5H). In newborn, MH was larger than MW, which accounted for 88% of the former but both MH and MW equalized after one month of development (about 70 – 80 mm SL).

Table 2. Wet weight (WW), length (SL), mouth biometrics, relative percentage of experimental prey in gut contents (items and dry weight) and estimated optimal prey size (OPS) in total length (TL) and width (W) based on mouth width (MW) of juvenile seahorses from 0 to 60 DAR.

Seahorse Juveniles	Juvenile Age (Days after male's pouch release)									
	0	2	5	10	15	20	30	40	50	60
WW (mg)	4.0±0.9	4.8±0.5	6.5±1.2	11.0±2.7	18±8	26±13	77±23	108±12	199±88	509±50
SL (mm)	14.7±0.3	15.2±0.5	16.9±1.0	20.1±1.5	24.5±2.9	26.9±4.0	40.0±4.5	44.3±1.5	52.9±6.4	72.2±3.1
Upper jaw (µm)	347±46	456±39	504±26	497±95	470±61	494±53	624±56	778±39	916±62	1144±72
Lower jaw (µm)	1734±25	241±25	276±24	215±22	257±37	227±23	279±52	313±31	344±36	356±59
Mouth Width (µm)	316±87	311±28	417±32	436±50	640±85	602±126	777±102	891±30	967±138	1323±320
Mouth Height (µm)	358±51	537±93	582±42	588±59	721±100	835±158	963±105	999±101	1017±282	1060±221
Mouth Area (mm ²)	0.09±0.03	0.13±0.03	0.19±0.03	0.20±0.04	0.37±0.09	0.40±0.16	0.59±0.08	0.70±0.08	0.79±0.31	1.39±0.10
Gut content	0	3	6	10	15	-	30	-	-	-
Relative%-Biomass										
<i>B. plicatillis</i>	0.57	0.21	0.09	0.18	0.51	-	0.38	-	-	-
<i>Artemia nauplii</i>	38.02	28.14	22.34	15.16	36.42	-	63.53	-	-	-
<i>Acartia tonsa</i>	61.41	71.65	77.57	84.66	63.07	-	36.09	-	-	-
Relative%-Items										
<i>B. plicatillis</i>	3.68	1.49	0.72	1.45	3.37	-	2.12	-	-	-
<i>Artemia nauplii</i>	53.68	43.74	36.67	26.31	52.19	-	76.52	-	-	-
<i>Acartia tonsa</i>	42.63	54.76	62.61	72.24	44.44	-	21.37	-	-	-
Estimated OPS	0	2	5	10	15	20	30	40	50	60
TL (µm)	457	450	603	630	926	870	1125	1289	1399	1914
W (µm)	144	142	190	199	292	275	355	407	442	604

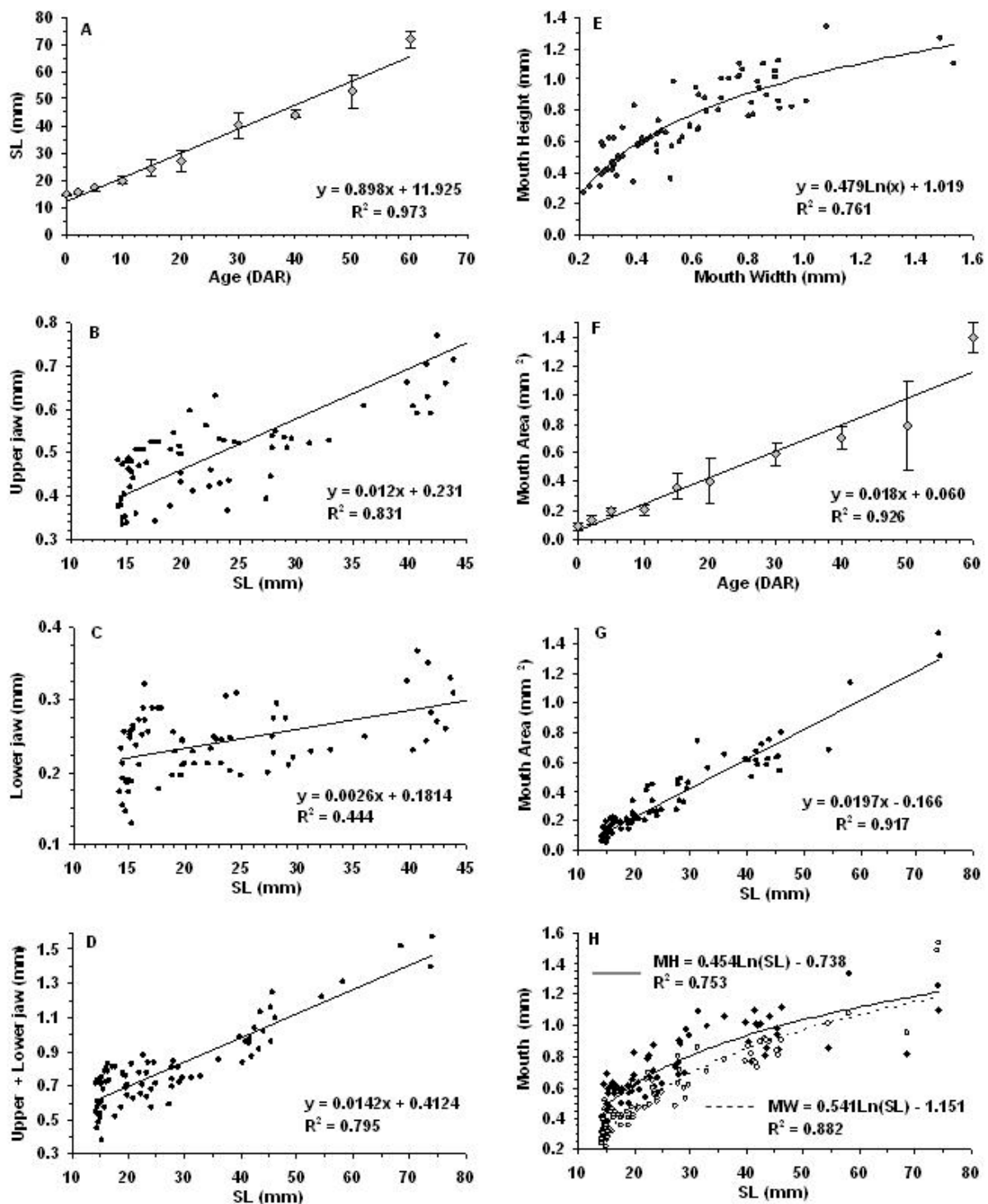

Figure 5. Relationship between mouth biometrics, and seahorse age and length in *H. guttulatus* juveniles from 0 to 60 DAR.

The average size (pTL, pW and pS) of prey types ingested during the early development of juveniles remained almost constant during the whole period of study. The size of ingested prey was not significantly different from the size of offered prey (T-test $(-1.98, 54.2)$, $p > 0.05$) (Figure 6). Mean length of ingested prey (pTL) was higher than mouth size at very early stages of seahorse development. However, pW was smaller, accounting for 38 – 29%

MH (0 DAR-30 DAR) and 56 – 36% MW (0 DAR-30 DAR) (Figure 6A). However, mean prey section was significantly smaller than mouth area of juveniles, accounting for only 22 – 1% MA (0 DAR-30 DAR) (Figure 6B).

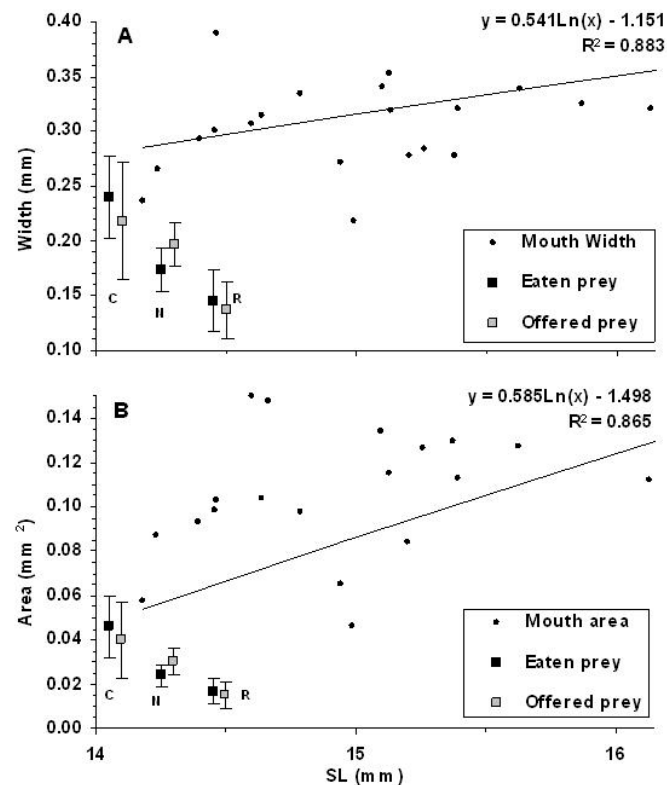

Figure 6. Width and section area (mean \pm sd) of prey (C: Copepods, A: *Artemia*, R: Rotifer) offered to seahorses or in gut contents. For comparative purposes, data on mouth width and mouth area of seahorse newborns are also provided.

3.4. Discussion

Snout anatomical characteristics and feeding kinematics of seahorses have been already studied in several studies, mainly on *H. reidi* (Leysen et al., 2011a, 2011b; Roos et al., 2009a, 2011; Van Wassenbergh et al., 2011, 2013). Most of the bonny structures and suction-flow dynamics were also described (Bergert and Wainwright, 1997; Leysen et al., 2010, 2011c; Roos et al., 2009b, 2010; Van Wassenbergh et al., 2009). However, studies on prey preference and selectivity in early developmental stages are scarce (Celino et al., 2012; Payne and Rippingale, 2000; Sheng et al., 2006; Souza-Santos et al., 2013). Seahorse newborns are capable to actively feed on live prey (Olivotto et al., 2011). In the present study, over 77% of first feeding newborn were able to ingest at least 1 prey item. Feeding incidence increased notably afterwards although feeding activity and prey preference were largely dependent on prey type. Rotifers are commonly used as first prey in some seahorse species (Olivotto et al.,

2011). However, newborn of *H. guttulatus* are larger than in most seahorse species and the ingestion of rotifers in our study was found to be merely anecdotal, since the juveniles clearly preferred the larger prey *Artemia* nauplii and *A. tonsa*.

Feeding is influenced by different factors such as prey encounter, attack and capture mechanisms, visible prey size, prey contrast and movement, or predation/prey-escaping behavior (Buskey et al., 1993; Shaw et al., 2003). Prey selection and capture rely on different factors such as prey color, prey availability, prey movement and escape capability, prey size, fish mouth size and previous hunting experience of the predator. Calanoid copepods *A. tonsa* and rotifers *B. plicatillis* are almost transparent prey whereas *Artemia* nauplii are opaque and orange colored and, therefore, more visible to predators. In addition, *Artemia* nauplii and especially rotifers move slowly, which would result advantageous to hunting seahorse juveniles. On the contrary, copepods move faster. The blurred vision of seahorse juveniles during feeding strikes has been hypothesized to result in lower capture success, which will improve with seahorse growth (Roos et al., 2010). In the present study, feeding incidence (FI) in newborn was slightly lower (77%) than in more developed juveniles (93% in 30 DAR). However, great differences were noticed considering the different types of prey offered to juveniles. FI was generally 0% (2% at 15 DAR) for rotifers, which showed a very low contribution to total prey items in guts at all ages. Hence, it is feasible that the ingestion of a few rotifers could be due to passive captures (e.g. accidental episodes of ingestion by suction forces when trying to feed on some other prey such as *Artemia* or copepods) rather than to active searching and capture.

Feeding success is especially important in early developmental stages. For hunting, *H. reidi*, newborns reach a 40° rotation angle in 2.5 mS (Van Wassenbergh et al., 2009), which allow them to feed on fast escaping prey (Roos et al., 2011). Since rotational time is shorter than escaping response of prey, it seems unlikely that escaping prey response would be a feeding constraint. However, pulsed or constant swimming motion may also be important as attractive stimuli for feeding preferences in fish (Buskey et al., 1993; Shaw et al., 2003). Almost one third of *H. guttulatus* newborn had only *Artemia* nauplii in their guts; the percentage was much higher in older juveniles. It is feasible that it was due to a more visible attractiveness of the nauplii for visual predators (Buskey et al., 1993), being easy to detect and capture for inexperienced seahorse newborn. However, in first feeding juveniles, gut biomass corresponding to copepods was almost twice that of *Artemia* nauplii. That finding might be

explained by the foraging theory according to which it is energetically preferably to hunt on a lower number of heavy prey than on higher number of prey with low individual weight (Townsend and Winfield, 1985). Accordingly, seahorses showed preference to feed on *Acartia tonsa* from 3 to 10 DAR. From that age, juveniles will progressively start to holdfast, changing from a pelagic to a demersal life. In *H. kuda*, it has been reported a higher energy demand before first-holding (Choo and Liew, 2006). From then until the end of the experiment, *Artemia* nauplii were clearly preferred over the other experimental prey.

Feeding success improve with increasing hunting experience (Reid et al., 2010; Shaw et al., 2003). Previous learning might affect prey selection behavior so that the fish might show preference for a familiar prey when both novel and familiar prey were offered together (Cox and Pankhurst, 2000; Meyer, 1986; Reid et al., 2010; Shaw et al., 2003; Wahl et al., 1995). In some fish larvae, feeding is enhanced by a strong learning component that took place in 1 to 5 days after being exposed to previously unknown prey (Cox and Pankhurst, 2000). In our study, younger juveniles might progressively learn how to successfully predate on copepods in the initial period when both *Artemia* nauplii and *A. tonsa* were offered to fish in the reserve rearing aquaria. After the end of administration of copepods (10 DAR) the relative proportion of copepods encountered in the gut was drastically reduced (from 75% at day 10 to nearly 21% at day 30). Despite prey hunting familiarity, ontogenetic shifts in prey preference have been previously reported in *H. trimaculatus*, changing from copepods to *Moina* and vice-versa (Sheng et al., 2006), and *H. kuda* fed on rotifers and two species of copepod (Celino et al., 2012). Ontogenetic changes in prey preference might be due to both evolutionary innate characteristics (Payne and Rippingale, 2000) and maximization of caloric reward per time unit (Celino et al., 2012; Confer and Lake, 1987) as reported in *H. kuda*, who showed higher preference for copepods over rotifers.

Prey preference in young fishes (Scharf et al., 2000) and particularly in seahorse juveniles is species-specific and change with development. Generally, prey preference with growth move towards the selection of larger prey. *H. trimaculatus* juveniles at very early stages prefer copepod nauplii and *Moina* nauplii over copepodites. The later are preferred from day 3 whereas adult copepods and *Moina* are preferentially selected at day 18 (Sheng et al., 2006). Even though, prey ingestion capability was unrelated to prey size in first feeding juveniles of *H. reidi* (Souza-Santos et al., 2013).

Although prey characteristics are decisive in feeding success, foraging mainly relay on the relationship between prey size and predator mouth size (Scharf et al., 2000). Although optimal prey size has been traditionally related to mouth width in other marine fish such as turbot (Cunha and Planas, 1999), the morphology of mouth in seahorses is very singular when compared to other fish species. Seahorses possess a tubular cylindrical snout that expand during strike and generate a flow strong enough to drawn prey by suction (Roos et al., 2010). That special morphology of mouth in seahorses would determine changes in prey selection when compared to other species. Seahorse newborns start exogenous feeding in a fully developmental stage with a functional digestive system (Blanco et al., 2013) and with a unique feeding strategy in which seahorses rotate their head in order to minimize prey–mouth distance (Roos et al., 2010). Even though snout of seahorses has been the focus of their feeding kinematics, little has been achieved on mouth dimensions and their feeding relationship (Souza-Santos et al., 2013).

In the present study, we analyzed mouth growth and its relation to prey size as a potential tool for the establishment of optimal prey sizes in developing *H. guttulatus* juveniles. Even that the experimental prey used are the most commonly used prey in the early rearing of marine fish, the results achieved seems to indicate that the offered prey are smaller than predicted for *H. guttulatus* juveniles, particularly in more developed individuals. Prey total length (pTL) showed the lowest correlation with any of the mouth measurements made. Average pTL in gut contents during the whole experimental period ranged from 122 to 92% MW in juveniles from 0 to 30 DAR, respectively and from 179 to 115% MH in juveniles from 0 to 30 DAR, respectively; hence, pTL resulted to be inadequate in the establishment of a feeding schedule for juveniles. Considering the feeding strategy of seahorses that ambush on their prey and attack them from their back (James and Heck 1994), the results achieved are not surprising. Conversely to pTL, prey width (pW) has been usually suggested as the best reference for prey-size selection in many different fish species (Anto et al., 2009; Bannon and Ringler, 1986; Cunha and Planas, 1999; Hambright, 1991; Scharf et al., 2000; Shaw et al., 2003). In turbot, *S. maximus* where described prey width was equivalent to 36 and 40 of MH and MW, respectively (Cunha and Planas, 1999). Taking into account all prey measurements made in or study, pW in gut contents ranged from 38 to 29% MH (0 – 30 DAR) and from 56-36% MW (0-30 DAR).

The calculated optimal pW (144 μ m) in first feeding juveniles was very similar to rotifer width, accounting for 40% of newborn MW (358 \pm 51 μ m). However, as reported above, rotifers were systematically rejected thorough the whole period studied. Rotifer rejection might be due to a mixture of factors, mainly their small size, low mobility and transparency. From the range of copepod sizes supplied (110-896 μ m TL; 74-305 μ m W) seahorses actively hunted on larger copepod stages, with sizes higher than 506 μ m TL and 182 μ m W, rather than on copepod nauplii. Considering that the average prey size of both offered and ingested prey was rather constant during the whole period of study and that seahorse mouth largely increased with development, the assessment of ideal prey sizes for juveniles would be unrealistic since the resulting sizes would be clearly underestimated.

Feeding performance in fish juveniles and adults has been previously related to mouth area (Kane and Higham, 2011). Newborns were able to ingest prey with a transversal section (pS) equivalent to 22% MA in juveniles. Applying that percentage to 0 – 30 DAR juveniles, the minimum pS would be 0.02 – 0.13 mm², which falls below the section area of *Artemia* nauplii and copepodites/adults of *A. tonsa*. Since a feeding strike is considered successful when the prey fits to fish mouth area and is ingested (Urtizberea and Fiksen, 2013), the decreasing pS/MA ratios with seahorse growth indicates that seahorse juveniles are able to capture and ingest much bigger prey than the offered.

Hippocampus guttulatus newborn are relatively large and have big mouths when compared to other seahorses such as *H. reidi*, whose juveniles start to feed successfully on rotifers (Souza-Santos et al., 2013). The larger size of *H. guttulatus* newborn implies that larger prey than rotifer and, even, *Artemia* would be preferable for their culture. Other seahorse species, such as *H. kuda*, are able to feed on small prey during the first days of exogenous feeding (Celino et al., 2012) preferring copepod naupliar stages rather than copepodites. *H. trimaculatus* newborn feed preferentially on *Artemia* nauplii (580 μ m in TL) when copepod nauplii (220 μ m in TL) were also supplied (Payne and Rippingale, 2000). However, seahorses grew and survived better when copepods were offered.

The upper limit of prey size is determined by the mouth size of the predator (Hunter, 1981). Therefore, the assessment of a diet based on live prey requires ascertaining the relationship between predator's mouth size and ingested prey size. However, there are other important factors that must be taken into account to define a successful feeding protocol in juveniles. One of those factors is the capacity of the fish to properly digest the prey. *H.*

guttulatus newborn have low capability to digest *Artemia* and that an efficient digestion of that prey is established from about day 10 (Olivotto et al., 2011) and improved from day 15 (Blanco et al., 2013). Although high survivals and growth rates can be achieved in cultures based exclusively on *Artemia* nauplii, rearing is significantly enhanced with the use of copepods, either alone or complemented with *Artemia* (Olivotto et al., 2011; Planas et al., 2012). Therefore, we recommend the use of copepods as first prey during the first days of development in *H. guttulatus* juveniles. In later stages when juveniles have already developed efficient digestion mechanisms, *Artemia* nauplii would be completely satisfactory to fulfill feeding requirements of juveniles. As prey selection is also based on species-specific prey characteristics such as swimming ability, color, availability and escaping mechanisms, the preference for *Artemia* nauplii could be related to their easier capture and visibility when compared to *A. tonsa* (Buskey et al., 1993). The shifting observed on prey preference (Ivlev index) of seahorse juveniles from copepods to *Artemia* nauplii from day 10 onwards might be due to the existence of an energetically conservative feeding behavior, as copepods are more active swimmers and probably more time consuming for hunting. Conversely, *Artemia* nauplii tend to be less dispersed in the surrounding media than copepods, displaying rather frequently a patching distribution. With growth, seahorse juveniles showed a progressive drop in their swimming activity, remaining near *Artemia* nauplii aggregates where hunting results more efficient. In spite of this, the minimum prey size does not necessary increase as rapid as maximum prey size (Scharf et al., 2000). Hence, *H. guttulatus* juveniles were still capable to feed on both copepod and *Artemia* nauplii even in older developmental stages.

The results achieved seem to indicate that seahorse juveniles would accept larger prey if available than those offered in our study. *Acartia tonsa* is not a large copepod and we suspect that feeding of juveniles from 10-15 DAR would be enhanced by supplying larger copepod species. However, this subject would require further studies. Also, specialization on available prey and/or hunting learning could had happen in the reserve aquaria from which juveniles were taken for the experiments carried out in this study. The effect of the original feeding regime on the results achieved in prey selection experiments could not be assessed in our study but will deserve attention in further studies.

3.5. Conclusions

Ontogenetic changes in mouth biometrics have been assessed for the first time in seahorse juveniles, particularly in *Hippocampus guttulatus*. From the whole set of data achieved and the analyses performed, and taking into consideration the size and types of prey used in the present study, we proposed that the feeding schedule for the early rearing of juveniles of the long snouted seahorse *H. guttulatus* would be based on copepods alone until 5 DAR, on a mixture of copepods and *Artemia* nauplii from 5 to 10 DAR and on *Artemia* only afterwards. Biometrics of mouth and prey selection data showed that early developing seahorse juveniles are very likely capable to ingest prey much bigger than those used in the present study and commonly supplied in the larval rearing of most marine fish. The use of the rotifer *Brachionus plicatilis* resulted inefficient in the feeding of juveniles.

CHAPTER 4

Improvements in the rearing of the seahorse *Hippocampus guttulatus* Cuvier 1829 by the use of copepods

Improvements in the rearing of the seahorse *Hippocampus guttulatus* Cuvier 1829 by the use of copepods

ABSTRACT:

First feeding and swim bladder hyperinflation have been a bottleneck for researchers and hobbyists worldwide in the rearing of juvenile seahorses. In the present study, the use of different prey types and the effects of aeration levels were assayed with the aim to improve feeding and to reduce swim bladder disorders in juveniles of the seahorse *Hippocampus guttulatus*. Juveniles were reared under two different aeration intensities (strong and weak) and fed until 30 DAR (days after male's pouch release) on three diets (A, M and C) which differed in the prey type supplied from 0 to 10 DAR. The juveniles were fed on *Artemia* nauplii in Diet A, on a mixture of *Artemia* nauplii + *Acartia tonsa* in Diet M and on *A. tonsa* (0-10 DAR) + *Artemia* nauplii (6-10 DAR) in Diet C. From 11 to 30 DAR, all juveniles were fed on a mixture of *Artemia* nauplii and enriched metanauplii. In the whole rearing period, especially from 0 to 15 DAR, growth and survival in juveniles from Diet A ($27 \pm 17\%$ survival at 30 DAR) were significantly lower than those from Diets M and C ($66 \pm 24\%$ and $76 \pm 15\%$, respectively). The effect of copepods in the diet was also noticed from 15 DAR onwards. The use of strong aeration levels resulted in a notorious reduction of mortalities associated to swim bladder hyperinflation and consequently in significantly increased survivals. The effect of the aeration level on juvenile performance was mostly evident in juveniles fed on diet A. From the whole results achieved in this study, the use of a feeding scheme including copepods for at least 5 days and the application of a strong aeration level in the aquaria are highly recommended in the early rearing of *H. guttulatus* juveniles.

4.1. Introduction

Despite efforts on seahorse culture are mostly focused on their trade for aquarium hobbyists, proper procedures might accomplish both conservation and socioeconomic objectives (Tlusty, 2002). Research on ornamental aquaculture has been highly recommended to improve management skills on these species by reducing its dependence on wild populations and ensuring their production, which would not compromise their natural habitat or non-targeted wild population status (Job et al., 2002; Tlusty, 2002; Vincent and Koldewey, 2006).

Feeding/nutrition have been traditionally a main bottleneck in the rearing of seahorses (*Hippocampus* spp.) (Vincent and Koldewey, 2006; Koldewey and Martin-Smith, 2010; Olivotto et al., 2011). Traditionally, intensive marine fish cultures have been carried out with diets based on rotifers and *Artemia* nauplii. Due to their easy availability and suitability, *Artemia* nauplii have been commonly used as early feeding prey in the rearing of many marine fish species including seahorses such as *Hippocampus abdominalis* (Woods, 2000a), *H. hippocampus* (Otero-Ferrer et al., 2010) and *H. whitei* (Wong and Benzie, 2003). However, some constraints have been reported in their use. The low digestibility of *Artemia* has been pointed out in young seahorses as well as in larvae of other fish species (Payne and Rippingale, 2000; Olivotto et al., 2011). Moreover, *Artemia* is not a natural prey in the marine environment and poorly fulfills the nutritional requirements of marine fish larvae, especially regarding dietary essential fatty acids and amino acids at first feeding (Sorgeloos et al., 2001; Drillet et al., 2006; Rajkumar and Kumaraguru, 2006).

Inadequate level of essential dietary compounds may reduce the larval physiological condition as well as survival and growth rates (Figueiredo et al., 2009). Culture failures have been reported in the early rearing of some fish due to the use of a diet based exclusively on *Artemia* (Rosenthal and Hempel, 1970; Chitty, 1981; Sorgeloos et al., 2001; Luizi et al., 1999). Newly hatched *Artemia* (Instar I) quickly develop into metanauplii (Instar II and III), such process rapidly consume the nauplii energy reserves, reducing considerably their free amino acid content, their digestibility, and therefore their profitability as an energy source (Sorgeloos et al., 2001). The nutritional and biochemical constraints of *Artemia* as prey for fish larvae first feeding have been partially solved by the progressive development and enhancement of prey enrichment procedures (Sorgeloos et al., 2001) which have been also applied in the rearing of seahorses (Chang and Southgate, 2001; Shapawi and Purser, 2003;

Wong and Benzie, 2003; Woods, 2003a; among others). Considering lipids, and particularly highly unsaturated fatty acids (HUFA), *Artemia* accumulates them in the body as triacylglycerols or storage lipids. In contrast, HUFA in marine natural prey such as copepods are more biologically available as they are mainly found in the polar lipid fraction (Schipp, 2006; Ajiboye et al., 2011; Barroso et al., 2013).

Copepods are considered a good alternative to *Artemia* mainly due to their biochemical profile. The culture of calanoid copepods as first feeding for fish larvae has been considered feasible since the late 1980s due to their biological and reproductive characteristics (Støttrup et al., 1986). Particularly, calanoid copepods have been recognized as an ideal prey for first feeding of many fish species, including seahorses, since growth and survival rates result significantly increased (Ajiboye et al., 2011). Feeding preferences and rearing performance (growth and survival) have been already assayed in some seahorse species (Payne and Rippingale, 2000; Sheng et al., 2006; Gardner, 2008; Olivotto et al., 2008; Pham and Lin, 2013) and the importance of copepods as supplementing or exclusive prey have been recognized.

Feeding of fish larvae is a complex process involving many biological and physiological activities where a high encounter rate with prey is essential to complete the feeding activity (Rønnestad et al., 2013). The distribution pattern of prey in the tank plays an important role in the feeding success of young fish. In *H. guttulatus* juveniles fed on *Artemia* sp. diets, strong aeration intensity has been related to higher survival rates; however, seahorses were smaller than when low aeration was supplied (Blanco et al., 2014). *Artemia* and copepods, especially calanoids, differ in movement patterns and escaping response, which can be affected by water turbulence and aeration intensity. Inadequate levels for those factors might unnecessarily increase the energy expenditure for prey capture and, consequently, hamper the rearing success (Utne-Palm and Stiansen, 2002; Sakakura et al., 2007; Oshima et al., 2009).

The objectives of the present study were (1) to assess the suitability of the calanoid copepod *Acartia tonsa* as first prey in the early rearing of seahorse *Hippocampus guttulatus* juveniles, (2) to test the effect of aeration intensity on the survival and growth rates and (3) to provide a novel and successful feeding schedule and rearing procedure for the early rearing of the species.

4.2. Materials and methods

4.2.1. Broodstock

Wild *Hippocampus guttulatus* adults were hand-caught collected from winter 2010 to summer 2012 at different locations in the Galician coast (NW Spain). The seahorses were conveniently transported to the rearing facilities at the Institute of Marine Research (IIM-CSIC) in Vigo (Spain), acclimatized, tagged, and transferred to 630 l aquaria as earlier reported (Planas et al., 2008b, 2012).

Seawater was pumped and 5µm mechanically filtered and UV treated at a renewal rate of 10-15 % of the total volume daily. Water quality was checked regularly for NO₂, NO₃ and NH₄/NH₃ content (0 mg L⁻¹) by using Sera Test Kits. Salinity (38 ± 1 ppt) and pH (8.1 ± 0.1) levels were monitored periodically. Adult seahorses were under gradually adjusted natural-conditions of temperature and photoperiod (Planas et al., 2013), from winter (15 °C and 10L:14O) and summer (19 °C and 16L:8O).

Seahorses were fed twice daily on adult enriched *Artemia* (EG, Iberfrost, Spain) and supplemented with wild-captured Mysidacea (*Leptomysis* sp. and *Siriella* sp.). *Artemia* enrichment consisted on a mixture of microalgae (*Phaeodactylum tricornutum* and *Isochrysis galbana*), 0.015 g L⁻¹ of Red Pepper (Bernaqua, Belgium) and 0.03 g L⁻¹ of Spirulina (Iberfrost, Spain) for at least 12 days; extra 0.08 g L⁻¹ of Red Pepper was supplied for at least 3 days prior to use it. Faeces and uneaten food were siphoned every day before feeding.

Pregnant seahorses were transferred from the broodstock aquaria to 30 L pseudoKreisel tank (18 °C and 16 L:8 D light regime) and maintained isolated few days before newborn release.

4.2.2. Rearing system

Seahorse newborn from ten different batches were used in the present study. Newborn were released from male's pouch from July 2011 to September 2013. After release, the juveniles were transferred to 30 L pseudoKreisel aquaria (Blanco et al., 2014) at an average initial density of 5 seahorses L⁻¹. The aquaria were operated in a semi-opened recirculation system including a degasifying column, two 50 L biofilters (20 µm mechanical and biological) and a skimmer. From the biofilters, the seawater was pumped to 36w UV light units and from there to 50 L reservoir tanks, being finally routed by gravity towards the aquaria for seahorse rearing. Seahorse juveniles were raised at 19 ± 1°C (Planas et al., 2012)

under a natural photoperiod regime (16L:8O). Waste (uneaten food and faeces) and dead juveniles were siphoned out from the aquaria 3-4 times daily.

4.2.3. Prey culture

Two prey types were used in the present study, the brine shrimp *Artemia* spp, and the calanoid copepod *Acartia tonsa*. *Artemia* cysts were disinfected and hatched at 28 °C for 20 h in 15 L incubators. Newly hatched nauplii were rinsed with tap-water for 30 minutes prior to be transferred to 5 L seawater buckets (100 *Artemia* ml⁻¹). For the production of *Artemia* metanauplii, the nauplii were enriched in 5 L buckets at 26 °C containing a 2 L mixture of the microalgae *Isochysis galbana* (10⁷ cells ml⁻¹) and *Phaeodactylum tricornutum* (1.6 10⁷ cells ml⁻¹), 0.3 g L⁻¹ of Red Pepper and 0.18 g L⁻¹ of Spirulina. *Artemia* metanauplii were rinsed with tap water for 30 minutes prior to be offered to seahorse juveniles.

Calanoid copepods (*Acartia tonsa*) were cultivated in large-volume tanks (250 - 500 L) at low densities (<1 adult ml⁻¹) and fed on 10 L mixtures of the microalgae *I. galbana* (10⁷ cells ml⁻¹) and *Rhodomonas lens* (16⁷ cells ml⁻¹). Siphoning, feeding and water exchange was performed every other day. Once a month, the rearing tanks for copepods were fully siphoned, bleached, rinsed and refilled with newly filtered seawater.

All prey were washed and sieved on different mesh size (125 µm for *Artemia* nauplii and 180 µm for copepods) and counted before seahorse feeding. Prey samples were taken, freeze-dried (Ilshin Lab Co., Ltd.), weighted using a Sartorius microbalance MC210P (± 0.01 mg) for dry weight (DW) and, finally, stored at -80 °C for further proximate biochemical composition analysis. In addition, prey samples were also randomly taken and photographed for total length (TL) measurements (n=30).

4.2.4. Experimental design

Three different feeding schedules (Diets A, M and C) were tested in the present study until 30 days after release (DAR). From 0 to 10 DAR, seahorse juveniles were fed on:

- Diet A: four daily doses of *Artemia* nauplii (1 nauplii ml⁻¹) delivered at 09.00, 12.00, 15.00 and 18.00h
- Diet M: a single dose of *Artemia* nauplii (1 nauplii ml⁻¹) was delivered at 09.00 and a single dose of *Acartia tonsa* (adults and copepodites, 0.7 copepod ml⁻¹) were offered at 15.00h.

- Diet C: from 0 to 5 DAR, a single dose of adult and copepodite of *A. tonsa* (0.7 copepods ml⁻¹) was delivered at 09.00h and, from 6 to 10 DAR, a dose of *Artemia* nauplii (1 nauplii ml⁻¹) was administered at 09.00h and a dose of *A. tonsa* (0.6 copepod ml⁻¹) was delivered at 15.00.

From 11 DAR until the end of the experiments at 30 DAR, all juveniles were fed on the same diets. Four daily doses of a mixture of *Artemia* nauplii and enriched metanauplii (1:1, 1 *Artemia* ml⁻¹) were offered at 09.00, 12.00, 15.00, and 18.00h.

Additionally, each diet treatment was assayed under strong and weak aeration intensity. Strong aeration was supplied by a stand-pipe producing big air bubbles (24 ± 3 mm in diameter) from the upper half side of the pseudoKreisel aquaria, near the outflow screened window. Approximately 11 ± 1 air bubbles sec⁻¹ were supplied at a mean velocity of 42 ± 3 cm sec⁻¹. Weak aeration was provided from the lower half side of the aquaria, below the outflow box, by small air bubbles (11 ± 2 mm in diameter) moving at a speed of 37 ± 3 cm sec⁻¹ and at a rate of 21 ± 3 bubbles sec⁻¹.

Each treatment was performed by triplicate.

4.2.5. Seahorse sampling

Seahorse samples (n=10-20) were taken at 0 and 30 DAR in Experiments 1 and at 0, 15 and 30 DAR in Experiment 2. Sampled seahorses were anaesthetised with MS222 (0.1 g l⁻¹), washed with tap water, transferred individually to Petri dishes and photographed for standard length (SL) measurements. Then, the excess of water was removed and the seahorses were pooled or individually weighted on a Sartorius microbalance MC210P (± 0.01 mg). Seahorses from samples taken at 30 DAR were awoken and transferred to their original aquaria. Estimated final survivals were adjusted considering sampling mortality.

SL was measured as head + trunk+ tail length (curved measurement), as reported by Lourie et al. (1999). Measurements were made on digital images using an image processing software (NIS, Nikon). Calculations involving development and growth were performed according to the formulations described in Otterlei et al. (1999) and applied to *H. guttulatus* juveniles by (Planas et al., 2012). Daily weight-specific growth rates (G; % day⁻¹) were calculated as:

$$G = 100 (e^g - 1)$$

where the instantaneous growth coefficient g was obtained by the following equation

$$g = (\ln W_2 - \ln W_1) / (t_2 - t_1)$$

where W_2 and W_1 are the average seahorse wet weights (mg) on times t_2 and t_1 , respectively, being t the time in days.

Fulton's condition factor (K_F) of juveniles was calculated as:

$$K_F = (WW/SL^b) * 1000$$

where WW was the wet weight and SL the standard length, b was the constant from the power tendency of the $WW - SL$ relationship.

In order to eliminate the batch effect on K_F over time, the ontogenetic increment of the Fulton's condition factor (ΔK) was calculated as follows:

$$\Delta K_F = K_{F(i) t_2} - K_{F(i) t_1}$$

where $K_{F(i) t_1}$ is the seahorse individual value of batch i at time t_2 (15 DAR or 30 DAR) and $K_{F(i) t_2}$ is the mean K_F value of batch i at a time t_1 (0 or 15 DAR, respectively).

4.2.6. Proximate biochemical composition

Total protein, total lipid, soluble carbohydrate and ash content in the experimental prey (*Artemia nauplii* and metanauplii and *Acartia tonsa*) were analysed. All samples were rinsed with tap water, sieved and freeze-dried prior to the analyses. All biochemical analysis were run by triplicate

Total lipids were analysed from 10 mg DW samples following a modification of the methanol : dichloromethane : MiliQ water (2: 2: 1) methodology (Bligh and Dyer, 1959; Fernández-Reiriz et al., 1989). Total protein and carbohydrates content in prey homogenates (1 mg ml⁻¹) were analysed as reported by Lowry et al. (1951) and by the phenol-sulfuric acid spectrophotometric method (Dubois et al., 1956), respectively. Ash content was determined gravimetrically after heating at 550 °C for 24 h (Mortensen et al., 1988).

4.2.7. Data analysis.

All statistical tests were carried out using the statistical package SPSS v.21 at a significance $p < 0.05$. Differences on the proximal biochemical composition in prey were tested by the non-parametrical Kruskal-Wallis test.

Differences on Fulton's K condition index increment (ΔK) and daily weight-specific growth rate (G) in seahorse treatments were tested by a Two-way ANOVA (aeration intensity

and diet). One-way ANOVA was used to test differences between treatments on average ΔK and G values for the whole experimental period (0-30 DAR).

Survivals at different developmental stages (5, 10, 15 and 30 DAR) were tested using a Two-way ANOVA. A MANOVA test was applied to WW and SL measurements at different developmental stages between experimental feeding and aeration conditions. All tests were Bonferroni post-hoc tested at a significance level of $\alpha = 0.05$.

4.3. Results

DW, SL and proximal biochemical composition of the three preys used in the experiment are shown in Table 1. Dry weight of copepods was higher than in *Artemia* nauplii and metanauplii ($p=0.047$). The prey significantly differed in SL ($p<0.05$; Copepods > *Artemia* metanauplii > *Artemia* nauplii) and carbohydrate content ($p<0.001$; Nauplii > Metanauplii > Copepods). The lipid content in *Artemia* nauplii was higher than in copepods ($p<0.05$); however, no differences were found between *Artemia* metanauplii and the other two preys ($p>0.05$).

Table 1. Dry weight (DW; $\mu\text{g indv}^{-1}$), standard length (SL; mm) and proximal biochemical composition (% DW) of the three prey supplied (*Artemia* nauplii, enriched *Artemia* metanauplii and *Acartia tonsa*) for the feeding of seahorse juveniles *Hippocampus guttulatus*. Kruskal-Wallis test: different letters indicate significant differences for mean.

ID	DW	SL	Protein	Carbohydrates	Lipids	Ash
Art. nauplii	2.3 ^a	0.643 ^a	43.0 ^a	11.6 ^a	21.4 ^a	14.5 ^a
Art. metanauplii	2.8 ^a	0.819 ^b	42.8 ^a	6.8 ^b	16.2 ^b	12.7 ^a
<i>Acartia tonsa</i>	4.6 ^b	0.763 ^c	38.4 ^a	3.3 ^c	11.8 ^b	12.4 ^a

Different letter superscripts represents significant differences ($p<0.05$)

Final survivals at 30 DAR in juveniles fed on Diet A (mean: $27 \pm 17\%$) were significantly lower than those from Diets M and C (mean: $66 \pm 24\%$ and $76 \pm 15\%$, respectively), independently of the aeration level supplied (Two-way ANOVA $F_{2, 12}=38.3$, $p<0.001$). On the other side, survivals in strongly aerated aquaria (mean: $71 \pm 24\%$) were significantly higher than in aquaria submitted to weak aeration (mean: $42 \pm 24\%$) (Two-way ANOVA $F_{2, 12}=38.8$, $p<0.001$).

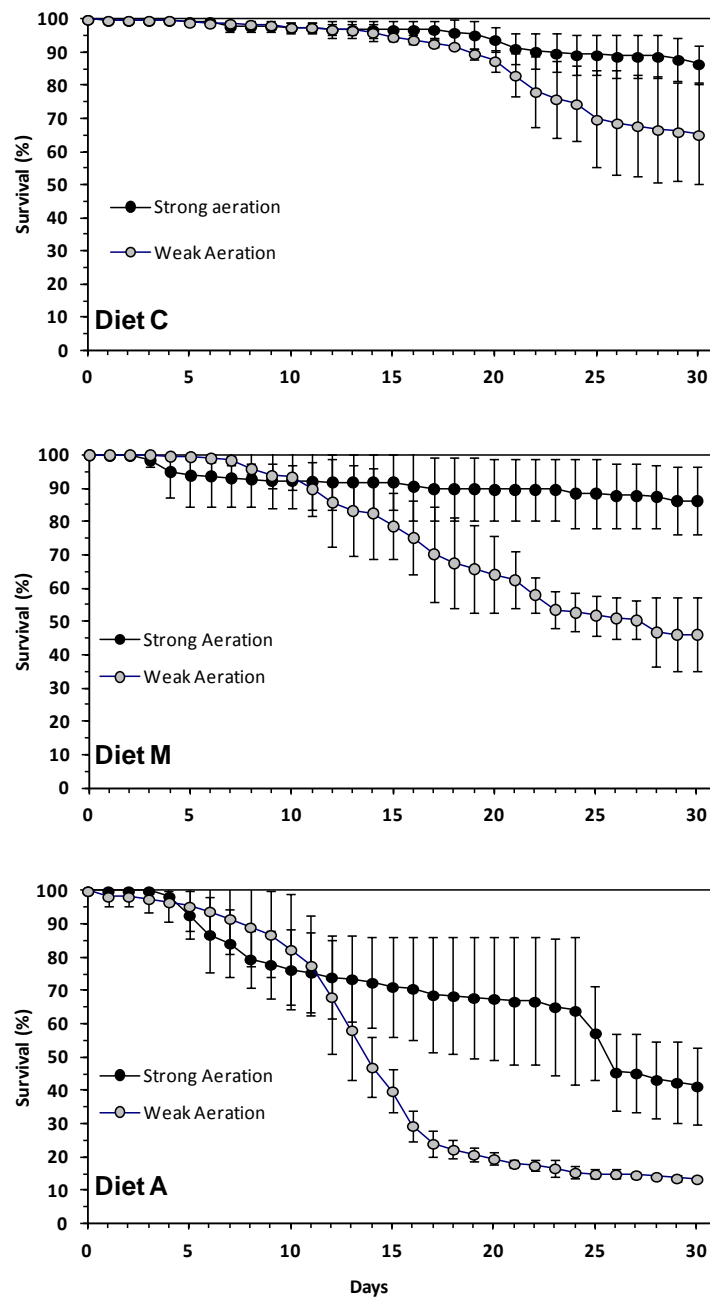

Figure 1. Survival rates in seahorse *H. guttulatus* juveniles reared under different feeding schedules (Diets C, M and A) and aeration intensities (Strong and weak).

Seahorse survival rates of juvenile seahorses are shown in Figure 1. Significant differences in survivals were also obtained at 10 and 15 DAR, when average survivals from treatment A were consistently lower than in treatments C and M. At 10 DAR (Two-way ANOVA $F_{2, 12}=6.3$, $p=0.013$), juveniles fed on Diet C showed higher survivals ($98 \pm 1\%$) than those fed on Diet A ($79 \pm 13\%$). Survivals in treatment M were slightly lower than in Diet C ($93 \pm 6\%$). At 15 DAR, the interaction diet – aeration level was significant (Two-way ANOVA $F_{2, 12}=4.4$, $p=0.037$). Seahorses fed on Diet A showed lower survivals at 15 DAR

than those fed on Diets C and M, both under strong ($p=0.01$ and $p=0.04$, respectively) or weak ($p<0.001$) aeration. The lowest survivals at that age were recorded in juveniles from Diet A raised in weakly aerated aquaria ($p=0.001$).

Standard length and wet weight relationships in juveniles for all experimental conditions assayed are shown in Figure 2. A significant interaction age (DAR) - diet - aeration (MANOVA, $F_{10,1490}=6.8$, $p=0.000$) was found for both WW and SL. At the end of the experiment, at 30 DAR, juveniles fed on Diet C performed better in terms of WW and SL than those fed on Diets A and M, independently of the aeration level supplied.

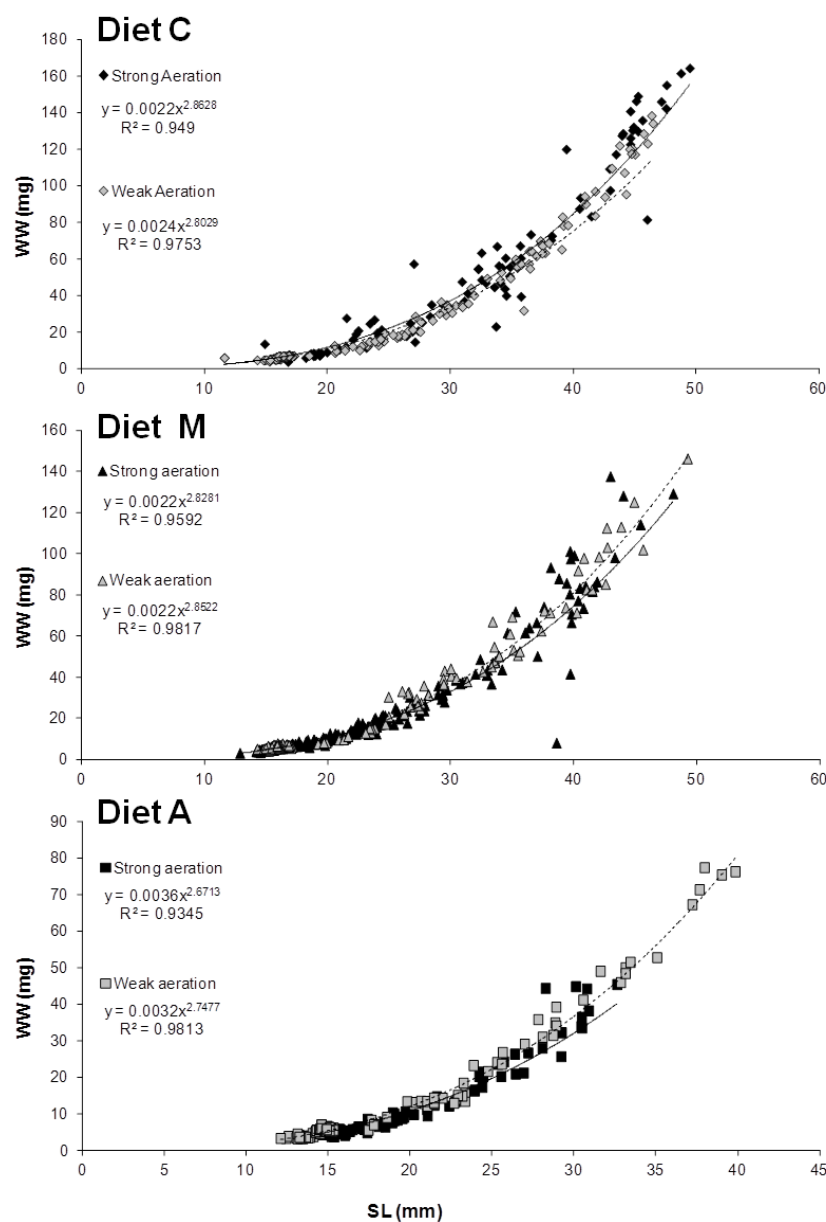

Figure 2. Wet weight (WW) and standard length (SL) relationships in seahorse *H. guttulatus* juveniles reared under different feeding schedules (Diets C, M and A) and aeration intensities (Strong and weak).

Aeration intensity affected differently to seahorse performance when reared on different diets. In Diet C, WW and SL of juveniles from strongly aerated aquaria (119 ± 30 mg and 44 ± 4 mm, respectively) were significantly higher ($p < 0.001$) than in those raised under weak aeration (WW: 88 ± 31 mg and SL: 41 ± 4 mm). Seahorses fed on Diet M under strong aeration also showed significantly ($p = 0.04$) higher WW, while no effect was shown for SL. Conversely, seahorse performance in seahorses from Diet A was higher ($p = 0.002$) than under weak aeration. Ontogenetic differences in WW and SL among treatments were significant from 10 DAR ($p < 0.05$), when seahorses reared under strong aeration fed on Diet C were heavier (20 ± 5 mg) and bigger (23 ± 3 mm) than those fed on Diet A, where juveniles had the lowest WW and SL (7 ± 2 mg and 18 ± 2 mm, respectively). Differences between Diets M and A were only significant for SL. At 15 DAR, the average weight and size of seahorses from Diet C reared either under strong (32 ± 3 mm and 45 ± 11 mg) or weak (31 ± 4 mm and 41 ± 18 mg) aeration were significantly higher than those from Diets A (strong: 22 ± 3 mm and 15 ± 6 mg; and, weak: 23 ± 4 mm and 20 ± 11 mg) and M (strong: 25 ± 4 mm and 21 ± 11 mg; weak: 28 ± 2 mm and 32 ± 7 mg).

Average daily weight-specific growth rates (G) (Table 2) from 0 to 30 DAR were significantly affected by the diet supplied (Two-way ANOVA, $F_{2,11} = 12.1$, $p = 0.002$) but not by the aeration level in the aquaria. Juveniles fed on Diets C ($G = 10.0 \pm 1.0$) and M ($G = 9.3 \pm 0.8$) showed higher G values than those from Diet A ($G = 7.2 \pm 1.0$) ($p = 0.002$ and $p = 0.011$, respectively). Those findings were the result of differential growth rates among diet treatments (Two-way ANOVA, $F_{2,12} = 5.9$, $p = 0.02$) during the initial period of feeding, from 0 to 15 DAR. During that phase, the growth rate in juveniles fed on copepods (Diet C) was also significantly higher than in those feed only on *Artemia* (Diet A) ($p = 0.014$). Conversely, the type of diet did not affect to G values in the period 15 to 30 DAR, when all juveniles were fed on the same prey. Indeed, differences among treatment during that interval were due to aeration intensity (Two-way ANOVA, $F_{1,11} = 5.3$, $p = 0.042$), with juveniles growing faster when raised under strong aeration conditions ($p = 0.042$).

Increments in Fulton's condition index (ΔK) with development (Table 2) for the whole experimental period were dependent on both diet and aeration level (Interaction Diet – aeration; $p = 0.005$). Increments were higher in juveniles fed on Diet C, particularly when raised under a weak aeration (weak vs strong, $p = 0.001$). Juveniles from Diets A and M, grown under weak or strong aeration, performed similarly. From 0 to 15 DAR, increments in

Fulton's K were also dependent on diet and aeration level ($p < 0.001$ in both cases). The lowest increments (negative values) were achieved in juveniles raised under strong aeration levels or fed on Diet A. In the period 15-30 DAR, ΔK values performed similarly to those for the whole experimental period, being significantly affected by both the type of diet and the aeration level (Interaction Diet – Aeration; $p = 0.005$). Increments in juveniles fed on the three diets were similar under strong aeration conditions and significantly higher than in seahorses from aquaria weakly aerated, where the higher ΔK values were achieved in Diet C and the lowest in Diet M.

Table 2. Daily weight-specific growth rate (G) and Fulton's K condition index increment (ΔK_F) for different ontogenetic intervals in seahorse juveniles reared under strong or weak aeration and fed on Diets C, M and A.

Diet	Air	G			ΔK_F		
		0 – 30	0 – 15	15 – 30	0 – 30	0 – 15	15 – 30
C	Strong	10.0 ± 0.1^b	12.5 ± 1.4^b	$7.9 \pm 0.2^{a,b}$	0.6 ± 0.5^b	-0.1 ± 0.5^b	0.6 ± 0.4^c
	Weak	9.9 ± 1.5^b	12.9 ± 3.0^b	$6.4 \pm 0.5^{a,b}$	1.0 ± 0.8^c	0.5 ± 0.6^c	0.6 ± 0.5^c
M	Strong	9.8 ± 0.7^b	$9.3 \pm 2.3^{a,b}$	10.0 ± 4.7^b	0.1 ± 0.2^a	-0.2 ± 0.2^{ab}	$0.3 \pm 0.2^{b,c}$
	Weak	$8.8 \pm 0.6^{a,b}$	$12.2 \pm 1.1^{a,b}$	5.4 ± 1.1^a	-0.1 ± 0.3^a	0.3 ± 0.4^c	-0.2 ± 0.3^a
A	Strong	6.9 ± 0.6^a	7.6 ± 2.5^a	$6.3 \pm 2.2^{a,b}$	-0.3 ± 0.7^a	-0.4 ± 0.4^a	$0.3 \pm 0.7^{b,c}$
	Weak	7.5 ± 1.4^a	$9.3 \pm 1.8^{a,b}$	$6.1 \pm 1.5^{a,b}$	0.0 ± 0.3^a	-0.2 ± 0.4^{ab}	0.2 ± 0.3^b

Different letter superscripts represent significant differences ($p < 0.05$)

4.4. Discussion

In the present study, the rearing success has been studied in juveniles of the seahorse *Hippocampus guttulatus* reared on three different diets under different aeration intensities. The overall results demonstrated that survival and growth rates of *H. guttulatus* juveniles were enhanced by using calanoid copepods as first prey and a strong aeration intensity. However, the application of a universal rearing protocol for seahorses is highly unreliable since newborn size, feeding preferences and digestion capabilities, among others, are species-specific characteristics (Olivotto et al., 2011).

In the wild, seahorse feeding episodes strongly depends on feasible prey encounter, which may cause high mortalities on weaker individuals (Sheng et al., 2007). Accordingly, the availability of adequate prey during the early developmental stages of fish is essential to enhance growth and survival. Appropriate prey size and nutritional content are crucial factors to successfully rear marine fishes (Wilson and Vincent, 2000; Willadino et al., 2012). Feeding, as the most decisive factor in juvenile seahorse survival, requires the establishment

of a successful feeding schedule (Correa et al., 1989; Lockyear et al., 1997; Payne and Rippingale, 2000; Woods, 2000a; Olivotto et al., 2008; Pham and Lin, 2013). Although *Artemia* and Rotifers are by far the most commonly used live food in the culture of different fish species (Sorgeloos et al., 2001), including seahorses (Koldewey and Martin-Smith, 2010), the nutritional requirements of marine fish larvae and also seahorse newborn are not always met when feeding on those prey (Payne and Rippingale, 2000; Drillet et al., 2008; Olivotto et al., 2008; Barroso et al., 2013).

The diets used in the present study differed on the type of live prey supplied but also on the schedule of prey distribution. The use of the copepod *Acartia tonsa* as sole prey during the first five days of life (Diet C) resulted in higher survivals and growth performance. Copepods have been considered an almost ideal prey to fulfill the nutritional requirements in first feeding marine fish larvae (Støttrup et al., 1986). Conversely to copepods, the use of *Artemia* and/or rotifers to feed young seahorse juveniles as previously reported low survival and growth rates in *H. reidi* (Olivotto et al., 2008), *H. guttulatus* (Blanco et al., 2011b; Olivotto et al., 2011), *H. subelongatus* (Payne and Rippingale, 2000) and *H. trimaculatus* (Sheng et al., 2006; Murugan et al., 2009). Newborn of some seahorse species, such as *H. reidi*, preferentially feed on rotifers (Souza-Santos et al., 2013). However, this prey does not seem to be adequate to *H. guttulatus* newborn, which systematically rejected rotifers, when supplied alone or combined with other prey due very likely to their small size (Blanco and Planas, 2014b).

The low capability to digest *Artemia* nauplii in newborn of some seahorse species, including *H. guttulatus*, (Payne and Rippingale, 2000; Olivotto et al., 2011; Blanco et al., 2013) suggested that feeding schedules including copepods could enhance seahorse rising at early developmental stages. It would be expected that copepods be easily digested than nauplii. A recent study reported a reduced digestive enzymatic equipment and also very low chitinolytic activity in 5 DAR *H. guttulatus* juveniles fed on diets including *Artemia* and/or copepods (Blanco et al., 2013). In spite of those findings, direct observations indicated that the degree of digestion of *Artemia* contained in fresh feces of newborn was notably reduced when compared to that of copepods. Hence, the enhancement of the initial seahorse rearing by copepods might be due to a cocktail of reasons including an easy digestibility and superior nutritional quality than *Artemia* nauplii.

Most fish larvae initially nourish from endogenous reserves (yolk) after hatching. After yolk exhaustion and mouth opening, the viability of the larvae is mainly based on a successful adaptation to exogenous feeding and adequate digestion/assimilation of nutrients. The transition from endogenous to exogenous feeding is one of the most critical phases in fish development (Rønnestad et al., 2013). Seahorse newborn lack yolk reserves, are fully developed after male's pouch release and exclusively dependent on exogenous feeding by actively hunting on live prey. The viability of young fish will be only possible when their nutritional and energetic requirements are met. Small peptides and free amino acids are essential energy sources to ensure enough protein dietary levels for growth (Rønnestad et al., 2003, 2013; Turner and Rooker, 2005; Ajiboye et al., 2011). In this regard, it is important to note that copepods have a higher proportion of free amino acids in terms of protein content than *Artemia* nauplii (Drillet et al., 2006, 2008). The copepods and *Artemia* nauplii used in the present study had similar protein contents and, although it was not analyzed, the free amino acid content would be higher in the former, increasing the nutritional value of copepods. That assumption is in accordance with the higher daily weight-specific growth rate in juveniles grown on Diets C and M, including copepods and the highest G achieved in juveniles fed solely on *A. tonsa* (Diet C) from 0 to 5 DAR. In addition, after the period of copepods supply in Diet C, G values from 15 DAR onwards decreased to the level of juveniles fed on the other diets. Hence, feeding juveniles solely on calanoid copepods enhanced significantly rearing of young juveniles.

Nutritional deficiencies of *Artemia* for the early stages of marine fish are well documented, especially with respect to essential HUFA (Sargent et al., 1997). Fish larvae have limited capacity to synthesized long chain polyunsaturated fatty acids from their precursors (Sargent et al., 1989, 1999; Chang and Southgate, 2001; Figueiredo et al., 2009) which are very important as main constituents of biomembranes and for central nervous system development and visual system functionality (Chang and Southgate, 2001; Rajkumar and Kumaraguru, 2006; Ajiboye et al., 2011). Copepods do not need to be enriched as for *Artemia* as they are a natural source of n-3 HUFA (especially EPA and DHA), vitamins and antioxidants (Rajkumar and Kumaraguru, 2006; Ajiboye et al., 2011; Lindley et al., 2011).

The development of enrichment diets for traditional prey in larviculture has been improved notoriously, especially for *Artemia*, (Lavens and Sorgeloos, 1996; Chang and Southgate, 2001; Wong and Benzie, 2003; Pham and Lin, 2013; Viciano et al., 2013).

However, the variability on the catabolism of the enrichments by different *Artemia* strains has been related to variable DHA and phospholipids kinetics (Sorgeloos et al., 2001; Viciano et al., 2013), which might led to unpredictable rearing results. *Artemia* HUFA is mobilized into triacylglycerol (storage lipids) which are biologically less available for the predator than HUFA stored as natural sources (structural or polar lipids) such in calanoid copepods (Ajiboye et al., 2011; Viciano et al., 2013).

Our results showed a clear enhancement of survival and growth in juveniles fed on copepods. The second factor analyzed in the present study, aeration intensity, seems to have a medium-term effect, especially when copepods were not supplied. Seahorses are physoclistus fishes that lack external connection to the lumen of the gas bladder and, consequently, need to gulp air from the water surface to inflate the swim bladder (Woods, 2000a; Fielder et al., 2002; Anderson and Petty, 2013). Swim bladder inflation in *H. guttulatus* generally occurs within the first hours of life and up to 1-2 DAR. However, under suboptimal rearing conditions, the manifestation of swim bladder dysfunctions (hyperinflation) is not uncommon and usually appears after 5-10 DAR (Woods, 2000a; Berzins and Greenwell, 2005; Payne, 2005; Olivotto et al., 2011; Palma et al., 2013). Affected juveniles would die in the following days (commonly from 10-20 DAR) due to the impossibility to feed normally. Swim bladder hyperinflation has been related to mass mortalities due to surface overcrowding (Martínez-Cárdenas and Purser, 2012). High turbulence conditions promote an even fish distribution in the rearing aquaria avoiding their accumulation near the water surface (Utne-Palm and Stiansen, 2002; Sakakura et al., 2006) and, therefore, reducing swim bladder hyperinflation. In the present study, seahorse survivals were significantly higher in aquaria submitted to strong aeration conditions.

Strong water turbulence requires higher energy demand to juveniles for swimming, feeding and grow (Nash et al., 1977; Utne-Palm and Stiansen, 2002; Oshima et al., 2009) which might affect the condition index of juveniles. Seahorse condition index increments (ΔK) were related to the type of diet, as expected, but also highly related for the whole experimental period to the aeration level applied. In general, the condition index of juveniles was initially (0 - 15 DAR) enhanced in weakly aerated conditions. This finding is very likely due to the usual negative net energetic balance occurring during the first days of life as already reported in other studies (Utne-Palm and Stiansen, 2002; Oshima et al., 2009). The negative balance would be reduced under less energy demanding conditions, that is, in less

turbulent or weakly aerated environments. Afterwards, the effect of water turbulence seemed to exert a lower effect on more efficiently feeding juveniles, especially when optimal rearing conditions are met (Diet C).

Although strong aerations have also been related to high mortalities due to harmful bubbling (Sakakura et al., 2007), *H. guttulatus* juveniles have a bony plated skeleton and an up-right position (Porter et al., 2013) that diminishes mechanical impacts, showing normal development and behaviour, with active hunting and swimming.

The major constraint in the use of copepods for larval rearing is related to culture instability when compared to *Artemia*, potential cross-contamination, low culture density, daily maintenance, and also cannibalism (Schipp et al., 1999). Additionally, copepod cultures are more time and space consuming and expensive to maintain than the readily available *Artemia* nauplii. A comparative study should be carried out for cost-effectiveness in the use of copepods and *Artemia* as prey in the early development of seahorse juveniles. However, from a biological point of view and net production, the use of a diet based on copepods as exclusive, or supplementation, prey and the establishment of strong aeration conditions was found to be the most convenient conditions to enhance the production of *H. guttulatus* juveniles.

4.5. Conclusions

The supply of an adequate first prey in the early development of *Hippocampus guttulatus* juveniles and the reduction in the presence of hyperinflated swim bladder were reached by supplying calanoid copepods in rearing submitted to strong aeration conditions. Although the use of copepods as a sole prey in first feeding juveniles resulted in significantly higher survivals and growth rates, a cost-effectiveness study is required to adjust the most adequate levels of copepods for an enhanced and low cost rearing procedure.

CHAPTER 5

**Ontogeny of digestive enzyme activities in juvenile long snouted
seahorses *Hippocampus guttulatus* fed on different live diets**

Ontogeny of digestive enzyme activities in juvenile long snouted seahorses *Hippocampus guttulatus* fed on different live diets

ABSTRACT:

Exogenous feeding in early developing fish encompasses important changes in their digestive enzymatic equipment and, therefore, in their capabilities to digest/assimilate prey. In seahorses, first exogenous feeding occurs immediately after male's pouch release of newborn. Survivals and growth rates resulted enhanced with the introduction of copepods in the diet, either alone or as supplement of brine shrimp *Artemia*. To assess digestive capabilities of long snouted seahorse *Hippocampus guttulatus* juveniles during early ontogenesis, the activities of trypsin, amylase, lipase and N-acetylglucosaminase (normalized to dry weight and specific activity) were investigated for the first time in juveniles fed on different diets based on *Artemia* and copepods (*Acartia tonsa*). Low activities in all the assayed enzymes were detected up to 15 days after release (DAR), with scarce differences among diet treatments. Chitinase activities were particularly low, which could explain the low digestion of *Artemia* during the first days of life. Since 15 DAR, the effect of diet composition became evident in juveniles previously fed on a mixed diet, containing *Artemia* nauplii and copepods, which showed a clear increase in all the assayed enzymes when compared to juveniles fed on *Artemia* as the sole prey. Differences encountered with age in enzymatic activities of juveniles fed on the assayed diets in the present study, have allowed suggesting a feeding scheme which ensures an adequate digestibility of the prey.

5.1. Introduction

Hatchery techniques of marine fish have been greatly improved over the last decades; however, mortality during early stages of development is still a main bottleneck in the production of marine juveniles for some fish species (Kim and Brown, 1994; Kim et al., 2001; Pérez-Casanova et al., 2006; Olivotto et al., 2011). Survival during the early developmental stages is closely related to food intake, feeding behaviour and starvation periods (Bolasina et al., 2006; Lazo et al., 2007; Furné et al., 2008). Critical periods in the early development of most marine fish generally occurs after the shifting from endogenous to exogenous feeding (Kim et al., 2001), the opening of the mouth and anus, and the development of the digestive tract (Ribeiro et al., 1999). The increasing complexity of the digestive tract implies changes in the digestion and assimilation of the ingested preys (Walford and Lam, 1993; Wardley, 2006). The development of stomach gastric glands or the pyloric caeca have been also pointed out as a main reason to explain differences in enzymatic activities during the early ontogeny of marine fish (Kim and Brown, 1994; Bolasina et al., 2006; Pérez-Casanova et al., 2006; Lazo et al., 2007; Furné et al., 2008; Kamarudin et al., 2011; Sanz et al., 2011; Srichanun et al., 2012; Gisbert, pers. com.).

Seahorses (*Hippocampus* spp.) are fishes of the Family Syngnathidae with very special characteristics. A progressive increase in the knowledge on their biology has permitted recent advancements in their rearing techniques (Olivotto et al., 2011). From a point of view of digestion capabilities, seahorse gut (both in adults and juveniles) is being mainly constituted by a simple intestine duct without a proper stomach (Wardley, 2006). This leads secondary implications on the digestion of food and their subsequent assimilation/mobilization for tissue formation and energy utilization. Even that feeding schedules have been determined for some seahorse species with relative rearing success, only a few studies have focused on digestive enzymatic activities in seahorses (Wardley, 2006; Álvarez et al., 2009; Quintas et al., 2010) and, thus, the information available is very scarce.

Important changes in enzymatic activities occur during the early development of seahorses after first feeding (Kim et al., 2001; Wardley, 2006). Despite newborn are fully developed and capable to ambush on live prey (Koldewey and Martin-Smith, 2010; Olivotto et al., 2011), the capability to digest *Artemia* during the early development of some seahorse species is questionable (Payne and Ripplingale, 2000; Planas et al., 2009b; Olivotto et al., 2011). Feeding on either *Artemia* or copepods has resulted in high survivals and growth rates

in several seahorse species (Payne and Rippingale, 2000; Woods, 2000a; Job et al., 2002; Sheng et al., 2006; Martínez-Cárdenas and Purser, 2007; Olivotto et al., 2008; Otero-Ferrer et al., 2010; Zhang et al., 2010; Celino et al., 2012; Willadino et al., 2012). In some seahorse species, such as West-Australian seahorse *Hippocampus subelongatus* Castelnau 1873 (Payne and Rippingale, 2000; Planas et al., 2009b) and Long-snouted seahorse *H. guttulatus* Cuvier 1829 (Blanco et al., 2011; Olivotto et al., 2011), an improvement in the rearing of juveniles with the addition of copepods in the diet either alone or supplemented with *Artemia* has been reported, probably due to a higher digestibility of the former.

Digestive enzyme activities have been proposed as an indicator of the nutritional condition of fish larvae (Bolasina et al., 2006; Lazo et al., 2007), helping researchers to improve diet composition design for fulfillment of the nutritional requirements of fish (Srichanun et al., 2012). The process of digestion includes a wide variety of digestive enzymes that can determine the digestibility of prey by fish larvae. Moreover, trypsin activity is directly connected to protein metabolism (Lazo et al., 2007; Lemieux et al., 1999) and considered an indicator of total digestion ability (Bolasina et al., 2006). Additionally, the essential role of trypsin in the digestive process of fish larvae relies on the fact that is the only enzyme that can activate other enzymes (Kamarudin et al., 2011; Lazo et al., 2007).

Considering all the aforementioned, the objectives of the present study were: a) to assess the ontogeny of some of the main digestive enzymes (Trypsin, Amylase, Lipase and N-acetylglucosaminase) during *H. guttulatus* early developmental stages, and b) to evaluate changes in their enzymatic profile when fed on different prey types, *Artemia* or calanoid copepods *Acartia tonsa* Dana 1849. The study would contribute to adjust accordingly the most appropriate feeding schedule for the rearing of this threatened species and to a better fulfillment of its nutritional requirements.

5.2. Material and Methods

5.2.1. Broodstock

Adult *H. guttulatus* were collected by scuba diving from 2010 to 2011 offshore in Galicia (NW Spain) and transported conveniently to the facilities at the Institute of Marine Research (CSIC) in Vigo (Spain). After their arrival to the laboratory, the seahorses were acclimated, transferred to 630 l aquaria units and submitted to natural photoperiod and

temperature regimes (Planas et al., 2008, 2013). The breeders were fed *ad libitum* three times per day on adult enriched *Artemia* supplemented with captured Mysidacea (*Leptomysis* sp. and *Siriella* sp.). The enrichment of *Artemia* was made on a mixture of the microalgae *Phaeodactylum tricornutum* Bohllin 1897 (1.6×10^7 cells ml^{-1}) and *Isochrysis galbana* Parke 1949 (10^7 cells ml^{-1}) and one daily dose (0.1 g l^{-1}) of Red Pepper (Bernaqua, Belgium) for at least 5 days. Faeces and uneaten food were siphoned out before feeding. Water quality was checked periodically for NO_2 , NO_3 and NH_4/NH_3 content (0 mg l^{-1}) by using Sera Test Kits. Salinity and pH levels were 38 ± 1 ppt and 8.1 ± 0.1 , respectively.

Three pregnant seahorses were transferred from the broodstock aquaria to 30 L aquaria ($18 \text{ }^\circ\text{C}$ and 12 Light:12 Dark light regime) and maintained isolated for a few days until newborn release. Three batches of newborn (one per male) were used in the experiments. Each batch was distributed into aquaria and submitted to feeding (2 batches) or starving conditions (1 batch).

5.2.2. Rearing system

Each newborn batch was raised ($5 \text{ juveniles L}^{-1}$) separately in 30 L pseudoKreisel aquaria. The rearing was carried out in semi-opened recirculation systems including a degasifying column and two 50 L biofilters with mechanical (up to $20 \text{ }\mu\text{m}$) and biological filters, aerators and skimmers. The seawater was pumped from the biofilters to 36w UV light units and after to 50 L reservoir tanks. Finally, the seawater was routed by gravity towards the rearing aquaria. The temperature in the rearing system was maintained at $19 \pm 1 \text{ }^\circ\text{C}$ (Planas et al., 2012) by using an inlet heating system (HC300/500 A, HAILEA). The total volume of the rearing system was renovated twice per hour by means of an external inflow (24 L h^{-1}) of $20 \text{ }\mu\text{m}$ filtered and UV- treated seawater.

A 16L:8D photoperiod regime was applied and lighting was supplied by 20w fluorescent lamps (Power Glo) placed laterally at 20 cm of the aquaria. Opaque black plastic films covered the half upper sides of the aquaria. Aeration was gently provided at 15 cm deep from the water surface near the outlet window of the aquaria. The seawater inflow (700 ml min^{-1}) was located above water surface in the opposite corner of the aeration inflow to ensure an adequate distribution of the seahorses into the aquaria.

5.2.3. Feeding conditions

Two batches of newborn were fed on different diet treatments (Diets A and M), differing in the type of prey supplied during the first 10 days after male's pouch release (DAR) as follows:

- Diet A (*Artemia* diet): Three daily doses (at 09.00, 13.00 and 17.00) of Great Salt Lake (GSL) *Artemia* nauplii (1 *Artemia* ml⁻¹ dose⁻¹).
- Diet M (Mixed diet): A single daily dose (09.00) of cultivated copepods (about 87% *A. tonsa* and 13% *Tisbe* sp.) at a density of 0.7 copepods ml⁻¹ from 0 to 5 DAR and a daily dose of GSL *Artemia* nauplii (09.00; 1 *Artemia* ml⁻¹) and copepods (18.00; 0.7 copepods ml⁻¹) from 6 to 10 DAR.

Three daily doses of *Artemia* nauplii + 24 h enriched *Artemia* metanauplii (1:1; 1 *Artemia* ml⁻¹ dose⁻¹) were provided in both treatments from 11 DAR until the end of the experiment at 30 DAR.

Copepods were cultivated on mixtures of the microalgae *I. galbana* (10⁷ cells ml⁻¹) and *Rhodomonas lens* Pascher and Ruttner (16⁷ cells ml⁻¹) in 250 - 500 L tanks. The enrichment of *Artemia* nauplii was carried out for 24h at a density of 100 nauplii ml⁻¹ on a mixture of *I. galbana* (10⁷ cells ml⁻¹) and *P. tricornutum* (1.6 10⁷ cells ml⁻¹).

In the aquaria for seahorse rearing, a window screened with 800 µm mesh during the day-light period allowed the exit of the remaining prey before the addition of each feeding doses. At night, water outlets were screened with 250 µm mesh to avoid prey from leaving the aquaria. Before feeding, wastes of remaining food and faeces were siphoned out, and dead seahorse removed and counted.

The experiment was finished at day 30, when survivors were counted and sampled (n=10). Sampled juveniles were weighted (after water excess removal) and photographed for further standard length measurements.

For a better assessment of the effect of feeding on enzyme production, a third batch of newborn (Treatment S) was transferred to 10 L rectangular aquaria (33 x 21 x 17 cm) similar to those described by Chamorro et al. (2010) and maintained deprived of food until death. Mortalities were recorded twice daily throughout the experimental period.

5.2.4. Seahorse sampling

Samples of seahorses (n=10) were taken at 0, 5, 10, 15 and 30 DAR in fed groups A and M and at 0, 1, 2, 3 and 4 DAR in the starved group, S. Sampled seahorses were transferred to aquaria deprived of food and let to starve overnight to allow full gut emptiness. Sampled seahorses were anaesthetized with an overdose of MS222 (0.1 g L⁻¹), washed with tap water, individually transferred to Petri dishes and photographed for standard length (SL) measurements to the nearest 1µm. SL was measured as head + trunk+ tail length (curved measurement), as reported by (Lourie et al., 1999). Measurements were made on digital images using image-processing software (NIS, Nikon). Then, the excess of water was removed and the seahorses were individually weighted on a Sartorius microbalance MC210P (± 0.01 mg). After this, the fish were frozen at -80°C, freeze-dried (Ilshin Lab Co., Ltd.) and stored at -80°C until determination of enzyme activities.

Effective day-degrees (D^o_{eff}) is an index of developmental progress based on a species-specific threshold temperature (T_o) at which development (growth in the present study) is theoretically arrested. D^o_{eff} have been used as a temperature (T) independent time-scale in order to standardize the data and make it comparable to other fish larvae studies. Therefore, we used the D^o_{eff} approach, previously applied to describe ontogenetic development in juvenile seahorses (Planas et al., 2012). D^o_{eff} was calculated as follows:

$$D^{\circ}_{\text{eff}} = \Delta t \cdot T_{\text{eff}} = \Delta t \cdot (T - T_o)$$

where T_{eff} is the biologically effective temperature (T_{eff} = T - T_o). T_o for *H. guttulatus* juveniles is 13.1±0.9 °C (Planas *et al.*, 2012).

Calculations involving development were performed according to the formulations described in Otterlei et al. (1999) and Planas et al. (2012). Daily weight-specific growth rates (G; % day⁻¹) in juveniles were calculated as:

$$G = 100 * (e^g - 1)$$

where the instantaneous growth coefficient g is obtained by the following equation:

$$g = (\ln W_2 - \ln W_1) * (t_2 - t_1)^{-1}$$

where W₂ and W₁ are the average seahorse dry weights (mg) on days t₂ and t₁, respectively.

Fulton's condition factor (K_F) was calculated as:

$$K_F = DW * SL^{-3} * 1000$$

with DW dry weight and L_s standard length.

The following third-order polynomial was fit to test the effect of the diets on the ontogenetic responses on non-esterase lipase activities (EA):

$$EA = a*(DAR)^3 + b*(DAR)^2 + c*(DAR) + d$$

where a, b, c and d are constants.

5.2.5. Enzyme activities determination

Enzyme extracts of single seahorse juveniles were prepared by manual homogenization using an Ultra Turrax (Ika, Germany) followed by sonication in distilled water in an ice bath with three short pulses of 3s (Vibra-cell, Sonics, USA). Homogenates were performed in 220 μ l (final volume) in juveniles from 0 to 15 DAR. For 30 DAR individuals, the head and the tail were cut down and the final volume of the homogenate was adjusted to 550 μ l. The homogenates were then centrifuged for 15 min at $11,000 \times g$ at 4 °C and aliquoted extracts were stored (-80°C) until being analyzed. The enzymatic activities were also evaluated in samples of the live prey (copepods and *Artemia* nauplii and metanauplii). Enzymatic activities were analyzed in Fluoroskan reader (ThermoFisher Scientific; U.S.A.) using 96-well CLINIPLATE black flat bottom microplates (Thermo Scientific).

Trypsin

The fluorescent substrate used for trypsin activity was Boc-Glan-Ala-Arg-methylcoumarin hydrochloride (SIGMA B4153), which was diluted in dimethyl sulfoxide (DMSO) to a final concentration of 20 μ M. Five μ l of the substrate were mixed with 195 μ l of 50 mM Tris-HCl, 10 mM CaCl₂ buffer, and 10 μ l of the diluted homogenate were added to the microplate for analysis. Fluorescence was measured at 380 nm (excitation) and 440 nm (emission) for 17 min at room temperature.

α -Amylase

Ultra Amylase Assay Kit (E33651) from Molecular Probes was used for the analysis. For each sample 100 μ l of the substrate solution from the kit was used and 10 μ l of each seahorse extract was added. Fluorescence was measured at 485 nm (excitation) and 538 nm (emission) at room temperature.

Non-specific esterases

Non-specific esterases were evaluated using three different substrates: 4-methylumbelliferyl butyrate (MUB; Fluka 19362), 6,8-difluoro-4-methylumbelliferyl octanoate (MUOc; Invitrogen D-12200) and 4-methylumbelliferyl oleate (MUOl; Sigma 75164). Non-specific esterase activities were measured following a modified method from Vaneechoutte et al. (1988). In brief, three stock solutions were prepared by dissolving 0.39 mg of MUB, 0.54 mg of MUOc and 0.69 mg of MUO in 1 ml DMSO, to which 100 μ l Triton X-100 was added. These stock solutions were then diluted in phosphate buffer pH 7.0 to a final concentration of 30 μ M of MU. Ten μ l of the diluted homogenate were added to the microplate and mixed with 190 μ l of fluorogenic substrate for the analysis of Butyrate-hydrolysing lipase (BHL), Octanoate-hydrolysing lipase (OcHL) and Oleate-hydrolysing lipase (OIHL) activities, respectively. Fluorescence was measured by duplicate reads at 355 nm (excitation) and 460 nm (emission) for 17 min at room temperature.

Chitinase

Chitinase activity was analysed using an Assay Kit (CS1030; Sigma) which provides three different substrates for the detection of the various types of chitinolytic activity: 4-Methylumbelliferyl N,N'-diacetyl- β -D-chitobioside (chitobiosidase activity), 4-Methylumbelliferyl N-acetyl- β -D-glucosaminide (β -N-acetylglucosaminidase activity), and 4-Methylumbelliferyl β -D-N,N',N''-triacylchitotriose (substrate suitable for endochitinase activity). A previous trial on those substrates showed that only endochitinases were present in seahorse samples (data not shown). Consequently, only the substrate 4-methylumbelliferyl β -D-N,N',N''-triacylchitotriose was used for chitinase activity in the present study. The substrate was diluted (1:100) in Assay Buffer to obtain the substrate solution. Ninety μ l of substrate solution were placed into each well of the microplate and mixed with 10 μ l of the homogenates. The samples were read twice; firstly the samples were placed at room temperature for 15min, and secondly by heating the samples to 40°C with a dry-bath for 10min. The Fluoroskan reader was pre-heated at 40°C for 40min.

All the assays, with the exception of those of chitinase, were performed at room temperature. Total activity was defined as enzyme activity per individual (mU ind^{-1}). Specific enzymatic activities analyzed in the extracellular extracts were normalized by DW (expressed as mU mg DW^{-1}) and by soluble protein content (U mg prot^{-1}). Soluble protein was

determined by the Bradford method (Bradford, 1976). In all the cases, units were calculated as μmol of methylumbelliferone released per min, using a standard curve as a reference.

5.2.6. Data analysis

The ontogenetic effects of the diet on DW, SL and enzyme activities in seahorses were analysed applying MANOVA test with sequential Bonferroni adjustment. Unlike univariate analyses, this analysis allows for the simultaneous comparison of enzymatic activities for diets and ages while maintaining the chosen magnitude of type 1 error ($P=0.05$) as well as considering the correlation between enzymes within diets. Robustness of MANOVA allows validating the results even when violating the assumptions of the test (Bray and Maxwell, 1985; Camacho Rosales, 1995; Walters and Coen, 2006). When significant multivariate effects were found, the univariate responses were examined. Pair wise effects were also analysed among the tested variables both on enzymatic activity and biometric responses.

Hydrolysing-lipase activity on butyrate, octanoate and oleate were also studied separately by considering the relative contribution of each specific activity to the whole lipase activity.

5.3. Results

Survival and growth achieved in the early development of the long-snouted seahorse *Hippocampus guttulatus* are provided in Table 1.

Table 1. Survival, dry weight (DW) and standard length (SL) in *Hippocampus guttulatus* juveniles fed on diets A and M. D°_{eff} : Effective day-degrees.

Day	D°_{eff}	Survival (%)		DW (mg)		SL (mm)	
		Diet A	Diet M	Diet A	Diet M	Diet A	Diet M
0	0	100	100	0.84 ± 0.05	0.87 ± 0.07	15.6 ± 0.5	15.5 ± 0.7
5	25	93	99	1.01 ± 0.27	1.34 ± 0.35	17.6 ± 1.2	18.9 ± 1.5
10	49	67	98	1.27 ± 0.47	2.95 ± 0.76	18.7 ± 2.1	24.6 ± 1.6
15	74	64	98	1.87 ± 0.71	5.51 ± 2.49	21.2 ± 2.5	30.0 ± 3.6
30	147	58	85	4.85 ± 1.18	17.73 ± 4.23	28.4 ± 1.8	42.0 ± 3.8

The effect of the feeding regime on survival was closely related to the prey type supplied during the first 5-10 days after first feeding. Final survivals at the end of the experiment (30 DAR) were 58% in Diet A and 86% in Diet M. At 5 DAR, the survival of juveniles fed only on *Artemia nauplii* (Diet A) was slightly lower (93%) than in those fed on

Diet M (99%). Since then, mortalities in Diet A were persistently higher than in Diet M. At 10 DAR, the mortalities achieved with diets A and M were 33 and 2%, respectively. Growth of juveniles in weight and size was also significantly higher in juveniles fed on Diet M, with final dry weights of 4.85 ± 1.18 and 17.73 ± 4.23 mg in diets A and M, respectively (MANOVA, $P=0.000$; Table 1). Statistical differences in weight between diets were found from 10 DAR onwards. Similarly, final SL in 30 DAR juveniles were 28.4 and 42 mm in diets A and M, respectively. Seahorses fed on copepods + *Artemia* (Diet M) grew faster, with significant differences in SL from 10 DAR onwards. Fulton's K_F index modelled as a function of age and diet, fit considerably well to a third polynomial regression (Figure 1). A first decrease in K_F values from 0 to 5 DAR were followed by increasing values until 30 DAR. The pattern of change in K_F values during the experiment was rather similar in both diets. However, a positive effect of copepods was noticed at 15 DAR. In both diets, the juveniles were fed exclusively on *Artemia* from 11 DAR onwards. Since 15 DAR, K_F values in both diets performed similarly.

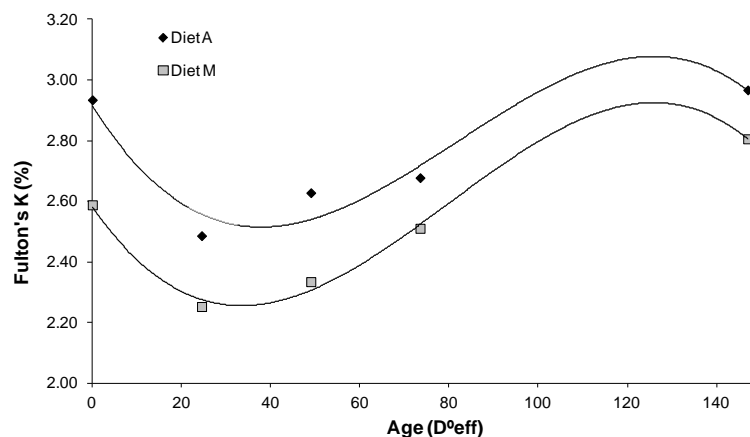

Figure 1. Fulton's condition index (K_F) in seahorse juveniles fed on diets A (*Artemia*) and M (Mixed diet).

Globally, changes in enzyme activities with age were evident in both dietary treatments. Nevertheless, different patterns were observed for each diet. The expression of enzyme activities in relation to juvenile dry weight offered a somewhat different picture (Figure 2). In the case of trypsin, values measured in fish fed on Diet A showed a progressive decrease with age, while those fed on Diet M showed a less marked decrease and even a sharp peak at 50 D°_{eff} (10 DAR). Patterns observed for esterase/lipase activities towards the different substrates assayed were also quite different. In the case of BHL, after an initial decrease, the activity was maintained during the experimental period, although significantly higher values were measured from 20 to 60 D°_{eff} . in juveniles fed on Diet M. The activity

towards oleate also showed significantly higher values in fish fed on Diet M during the same period and a further increase with age in both dietary treatments. In contrast, the activity of OcHL was rather constant in fish fed on Diet M, while it was higher in Diet M during the initial stages. Nevertheless the great variability of data resulted in the absence of significant differences between treatments. Finally, the activity of chitinase showed very low values, no changes with age and no differences between dietary treatments.

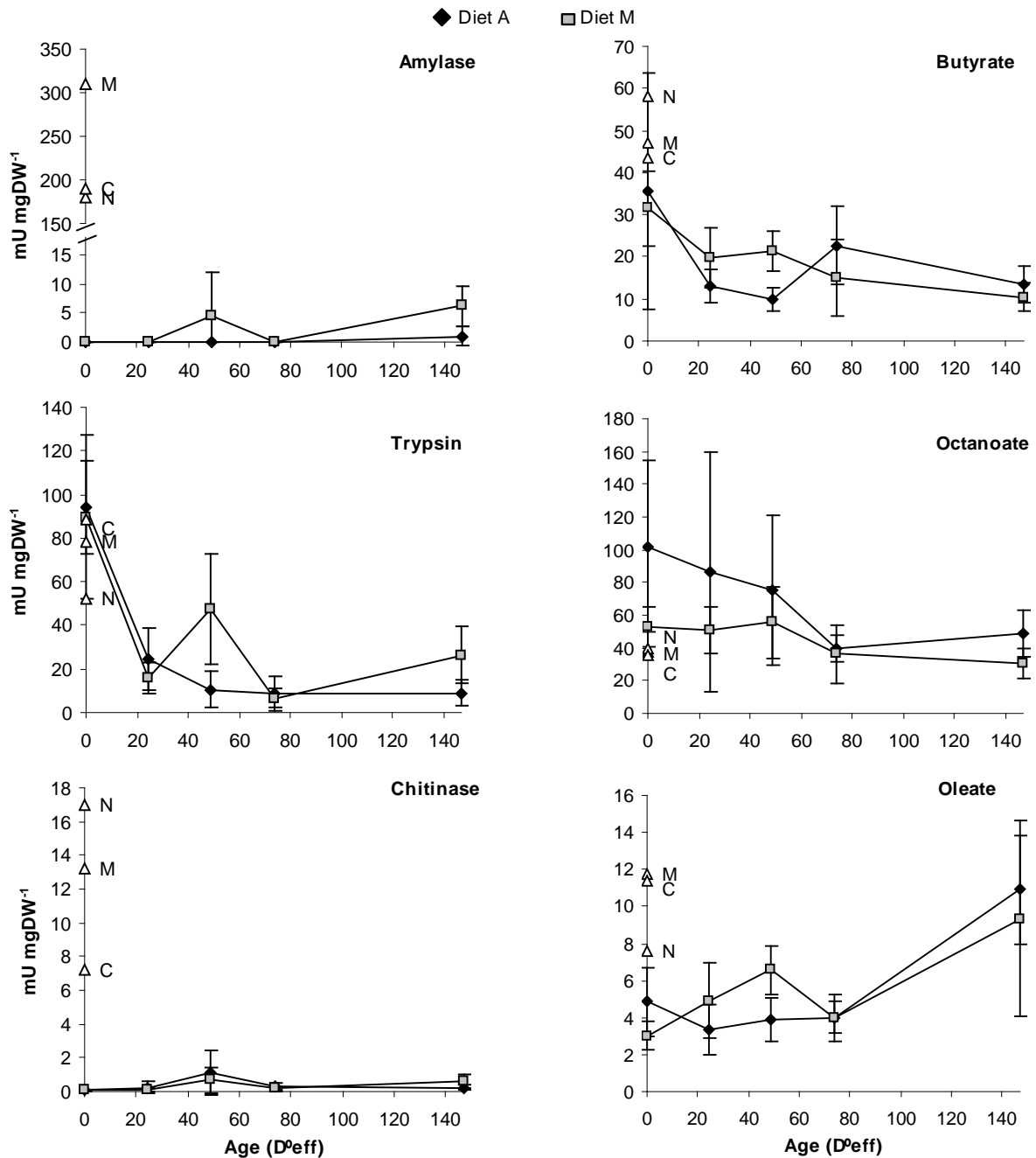

Figure 2. Normalized enzymatic activities (mU mg DW⁻¹) in seahorse juveniles fed on diets A and M. White triangles show specific enzymatic activities in prey (C: Copepods, N: Artemia nauplii and M: Artemia metanauplii).

Since the profiles obtained were almost identical when enzyme activities were expressed in relation to soluble protein or to individual, the results of the later are not reported for simplicity. Whereas juveniles fed on Diet M (*Artemia* + copepod) showed a clear increase in all enzyme activities (U mg Prot^{-1}) with age, those from Diet A (*Artemia*) showed an stagnation and even a decrease in trypsin and chitinase activities, with levels remaining very low when compared to those in treatment M (Figure 3).

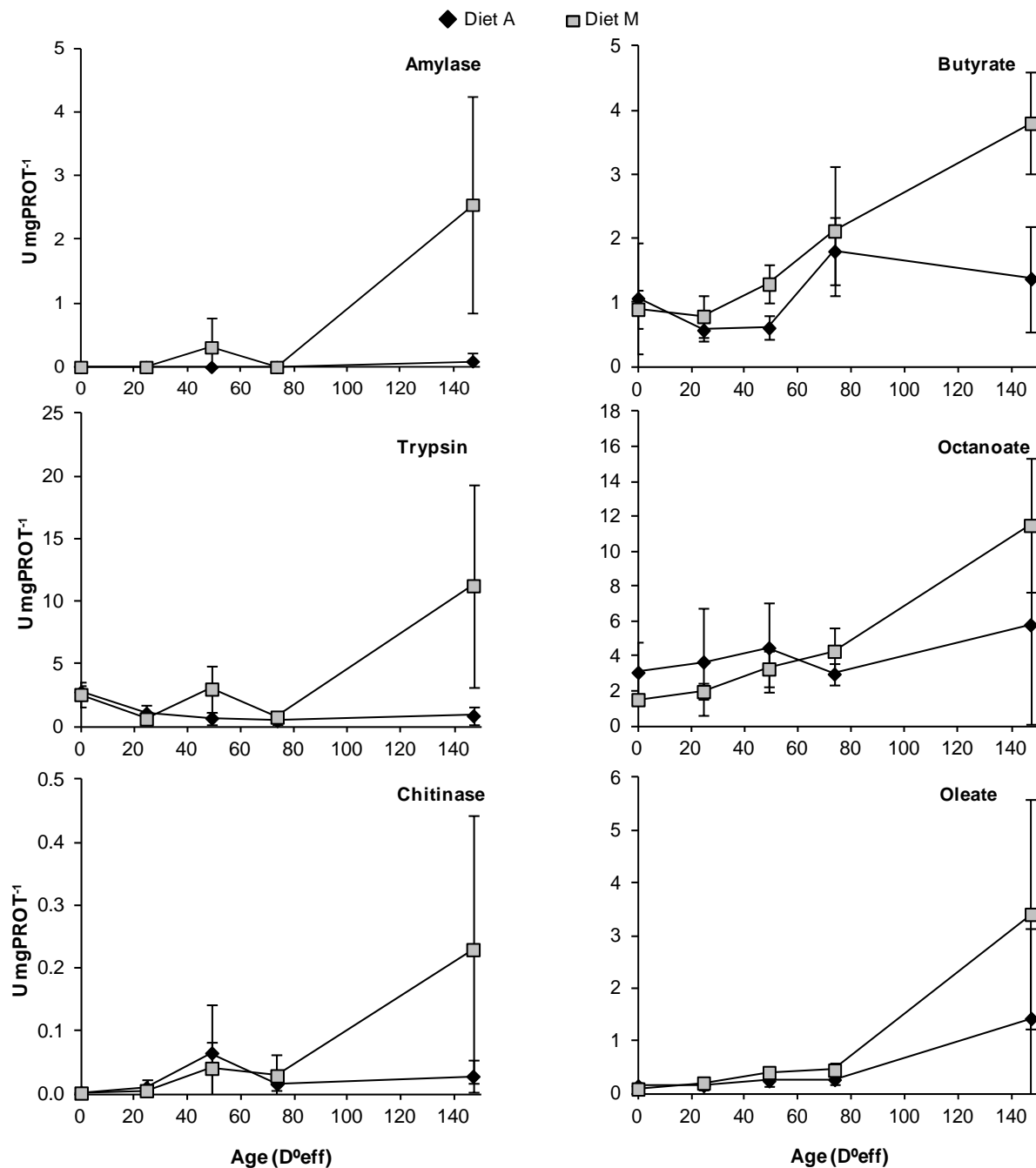

Figure 3. Specific enzymatic activities by soluble protein (U mg Prot^{-1}) in seahorse juveniles fed on diets A and M.

In contrast, esterase/lipase activities measured with any of the substrates assayed showed significant increases with age in both dietary treatments, although again values measured in juveniles fed on Diet A were significantly lower than those in Diet M. It was noticeable that esterase/lipase activities measured towards octanoate were twice as high as those measured to either butyrate or oleate (Figure 4).

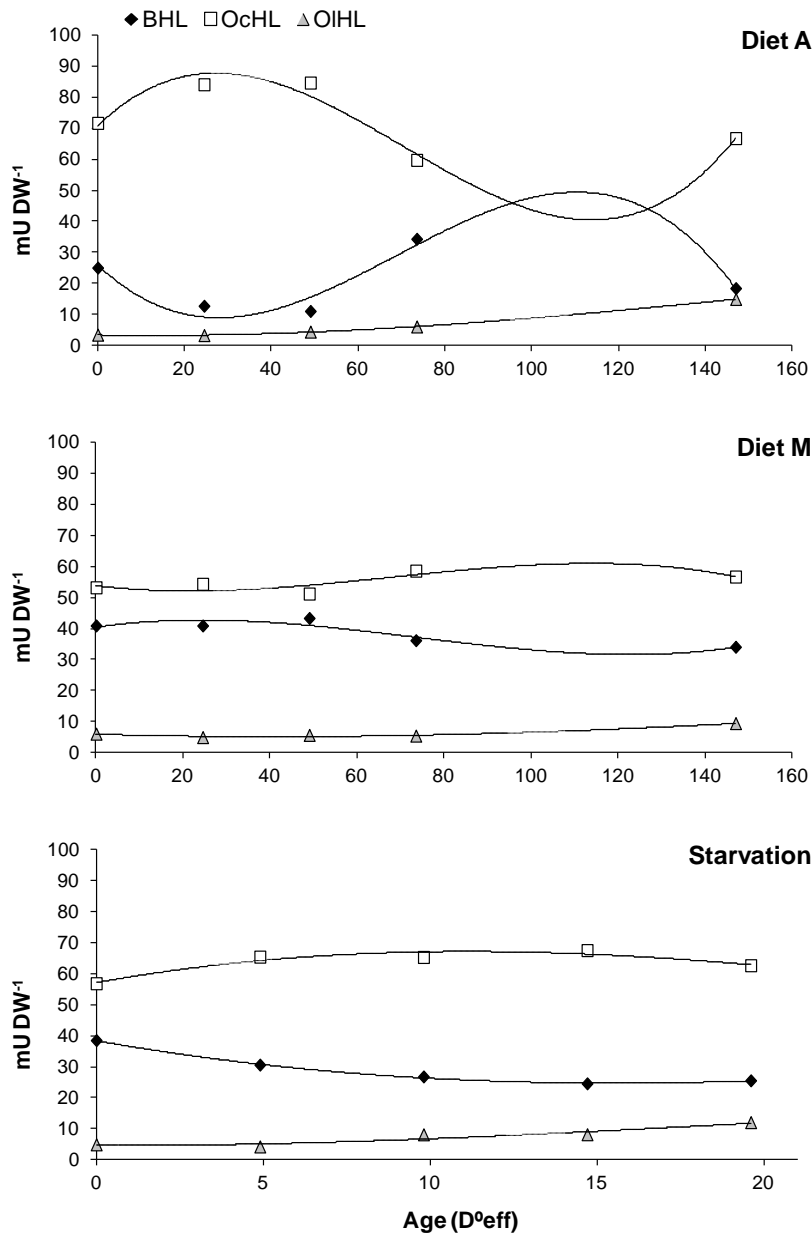

Figure 4. Relative percentages of BHL (Butyrate-Hydrolyzing Lipase), OcHL (Octanoate-Hydrolyzing Lipase) and OIHL (Oleate-Hydrolyzing Lipase) in relation to overall non-specific esterases normalized activities (mU DW⁻¹) in juveniles fed on Diets A and M or starving.

The effect of starvation and feeding on the activity of digestive enzymes from 0 to 5 DAR is provided in Figure 5 for comparative purposes. A similar reduction in the activity of trypsin to either starved or fed (both with Diet A and M) juveniles was evidenced. During the first five days of life similar reductions of the other enzymes (esterase/lipase assayed with the different substrates) were obtained when juveniles were starved or fed on Diet A. While those fed on Diet M showed a smoothly decreasing trend for BHL, a slightly increase activity (OcHL) or even a pronounced increase (OIHL) when compared to the other treatments.

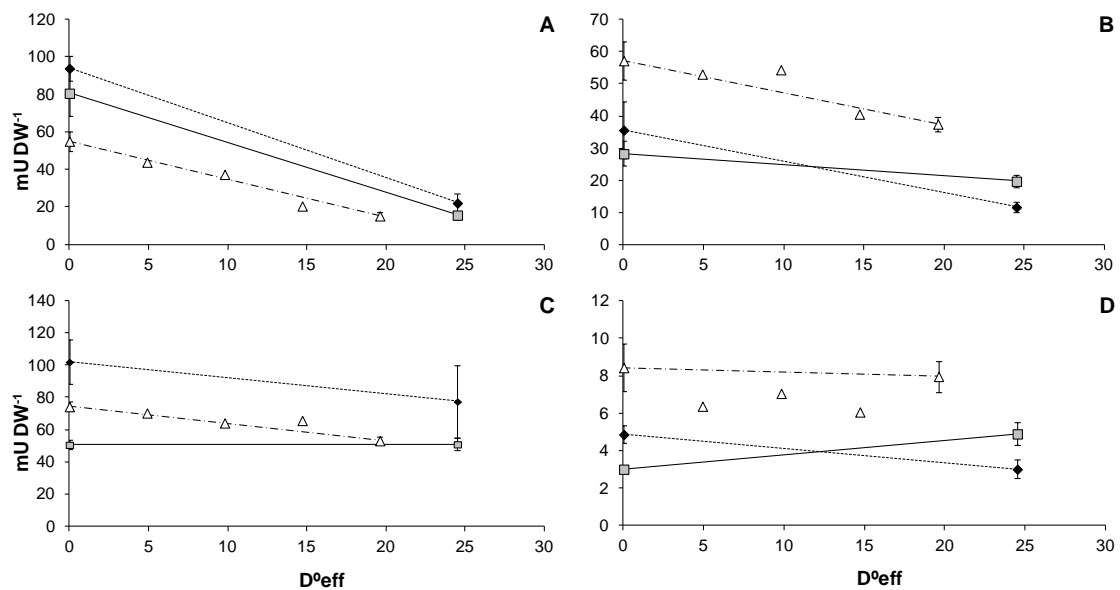

Figure 5. Specific enzymatic activities (mU DW⁻¹) for trypsin, BHL, OcHL and OIHL in starved and fed seahorse juveniles during the first 5 days after release (expressed as D^o_{eff}). Lines show the general trend from the start (0 DAR) until the end (5 DAR) of the starvation experiment.

5.4. Discussion

The onset of feeding is a critical stage in the development of marine fish (Govoni et al., 1986). The yolk sac is the unique nutritional source in most marine fish before the onset of exogenous feeding. Poor survivals are closely related to inappropriate prey availability and/or low food quality after yolk exhaustion (Yúfera and Darias, 2007). Yolk is lacking in seahorse newborn, which are fully developed and physiologically functional, and have all the anatomical organs prepared to fulfil survival requirements (Sheng et al., 2006). Conversely to most fish larvae, seahorse newborn are capable of actively forage and predate on available prey immediately after birth (Yin and Blaxter, 1987). Due to the lack of endogenous reserves,

they need to start feeding soon after male's pouch release although food deprivation for the first 24h has been reported to enhance survival in some seahorse species (Sheng et al., 2006).

The evaluation of the activity of digestive enzymes during the initial stages of development in different fish species is a common tool to assess maturation of their digestive system (Ribeiro et al., 1999; Bolasina et al., 2006; Kamarudin et al., 2011). In the case of marine fish, it provides important information on the more suitable moment to introduce changes in the feeding pattern as well as on the suitability of diet composition since the onset of first feeding. Digestive tract of seahorse juveniles is already functional although less developed than in adults (Yúfera and Darias, 2007) and does not possess a functional stomach. Thus, protein digestion mainly relies on pancreatic and intestinal proteases (Bolasina et al., 2006; Lazo et al., 2007). According to seahorse physiology, all the digestive activities analyzed in the present study corresponded to pancreatic enzymes. Those pancreatic enzymes are secreted by the exocrine pancreas to the intestine lumen, where digestion takes place, and increase with development (Zambonino Infante and Cahu, 2001; Papadakis et al., 2013).

The appearance of episodes of gut development is species-specific and the differentiation and functionality of some digestive tract regions may occur with a few days delay depending on egg quality, newborn size, temperature or feeding regime (Govoni et al., 1986; Gisbert et al., 2004; Faulk et al., 2007; Papadakis et al., 2013). There is a lack of information regarding the development of the digestive tract in the Long-snouted seahorse *Hippocampus guttulatus*. However, it is known that a few detectable changes occur with ontogeny in the Big-bellied seahorse *H. abdominalis* Lesson 1827 digestive tract such as the appearance of both an intestinal valve that separates the rectum from the rest of the intestine (7 DAR), and an intestinal loop with a mucosa layer strengthened (21 - 35 DAR) (Wardley, 2006).

In this study, enzyme activity profiles reflect a slow development of secretory organs and hence limited digestive capabilities at early developmental stages of *H. guttulatus* since the main enzymes showed low activities during the initial 15 DAR. From that moment onwards, the effect of diet composition became evident, and juveniles fed on the mixed diet showed a clear increase in all the assayed enzymes. In this sense, the lower the decrease of a given activity with age, the higher its importance in the total context of digestive enzymes.

The only exception to this trend was observed in the esterase/lipase activity towards octanoate.

Digestion capacity depends on the diet rather than on the feeding activity (O'Brien-MacDonald et al., 2006). Seahorse juveniles are capable to actively feed on prey since male's pouch release. Therefore, in spite of the availability of prey, digestion capabilities in juveniles must be adequate to ensure food breakdown and assimilation, and satisfy their energetic demand. It has been reported earlier that the brine shrimp *Artemia* is nutritionally poor and hardly digested for early developing juveniles of *H. guttulatus* (Olivotto et al., 2011; Planas et al., 2012) as well as other fish species such as Atlantic herring *Clupea harengus* L. 1758 (Rosenthal and Hempel, 1970), Anchovy *Anchoa* spp. (Chitty, 1981), Atlantic Halibut *Hippoglossus hippoglossus* L. 1758 (Luizi et al., 1999). The presence of almost intact *Artemia* nauplii in different gut regions has been related to fast gut transit and/or insufficient enzymatic equipment (Gisbert et al., 2004; Planas et al., 2009b; Olivotto et al., 2011).

Amylase and chitinase activities followed a similar pattern to that described for trypsin. Amylase activity has been widely described in several species of adult fishes such as Adriatic sturgeon *Acipenser nacarii* Bonaparte 1836 and Rainbow trout *Oncorhynchus mykiss* Walbaum 1792 (Furné et al., 2008) and in larval stages of Asian redbelly catfish *Mystus nemurus* (Valenciennes 1840) (Kamarudin et al., 2011), Senegalese sole *Solea senegalensis* Kaup 1858 (Ribeiro et al., 1999) and the big-bellied seahorse *H. abdominalis* (1 to 56 DAR) (Wardley, 2006). In the present study, amylase activity was always low or almost undetectable except in 30 DAR juveniles, when the activity increased significantly, especially in fish fed on Diet M. An increase in amylase activity has been reported in *H. abdominalis* from the time of male's pouch release (0.089 ± 0.013 mg of protein⁻¹ seahorse⁻¹) until 28 DAR (approximately 0.26 mg of protein⁻¹ seahorse⁻¹; data extracted from figure), when activity seemed to remain relatively constant (Wardley, 2006). The discordance between our and Wardley's results might be due to: a) the use of different analytical methodologies (Wardley, used colorimetric technique); and more probably b) species-specific differences in digestive enzymatic activities. Since amylase activity is related to the degradation of carbohydrates and, thus, to omnivorous feeders (Furné et al., 2008), the huge increase observed at later stages of growth might be due to an active feeding on *Artemia* metanauplii enriched on a mixture including the microalgae *I. galbana* and *P. tricornutum*. As in more advanced developmental stages, seahorse newborn actively ambush on plankton (Lourie et al.,

1999), leading to a low amylase activity in early ontogeny. In fact, low carbohydrate concentrations (including glycogen) and a consequent poor utilization of this substrate as energy source have been previously reported in starving *H. guttulatus* juveniles at early stages (Blanco *et al.*, 2011). In older juveniles, when prey intake increases and the nutritional condition improved, amylase activities increased moderately in agreement with Munilla-Morán and Saborido-Rey (1996). Amylase activity is detected early in the life history of many species of fish larvae (Kim *et al.*, 2001; Gisbert, pers. com.). Amylase ontogeny profile has been correlated with the secondary development of the gastrointestinal tract (Kim *et al.*, 2001). It has been suggested that the presence of amylase activity in young seahorses may be related to the ability to digest chitinous exoskeletons of crustaceans (Wardley, 2006). Chitin represents a main component of carbohydrates in marine environments (Gutowska *et al.*, 2004; Ikeda *et al.*, 2009). In this sense, chitin degradation occurs by a two-component chitinolytic enzyme system. Chitin is firstly hydrolysed by chitinases into oligosaccharides (exoskeleton disruption) and subsequently degraded to monomers (nutritional digestion) by β -N-acetylglucosaminases (Gutowska *et al.*, 2004; Molinari *et al.*, 2007; Ikeda *et al.*, 2009).

A comparatively low activity of trypsin in relation to the rest of enzymes was detected, which was in contrast to the significant protease activity described during the initial stages of development in other marine fish (Alliot *et al.*, 1980; Munilla-Morán and Stark, 1989). This should be related either to a lower requirement of nitrogen in this species or to a reduced ability to obtain it under the form of complex macromolecules instead of more simple forms like free amino acids (Rønnestad *et al.*, 2003).

In addition to proteins, lipids are the main energy source in seahorse newborn (Blanco *et al.*, 2011b). Fish larvae have the capacity to digest and assimilate lipids from the start of the exogenous feeding (Sargent *et al.*, 1989, Izquierdo *et al.*, 2000, Papadakis *et al.*, 2013) and are essential for fish larvae growth as the most important fuel source (Planas *et al.*, 1993; Zambonino Infante and Cahu, 2001). The action of lipases is directed towards the hydrolysis of dietary essential fatty acids from fats, which are very important for development, growth and survival of larvae/juveniles (Bolasina *et al.*, 2006).

Lipid vacuoles accumulation as a result of the ingestion of *Artemia* and especially of copepods occurred in the liver of meagre larvae (Papadakis *et al.*, 2013). Gisbert *et al.* (2004) reported no accumulation of lipids in the pre- and post-valvular intestine of California halibut *Paralichthys californicus* (Ayres 1859) larvae fed on *Artemia*. Similarly, Luiz *et al.* (1999)

reported a lack of lipid vacuoles in the intestine region of *H. hippoglossus* larvae. Those authors suggested that the adequate digestion of *Artemia* only occurs after the appearance of teeth for mechanical disruption or the stomach differentiation by pepsin activity and hydrochloric pre-digestion of prey. In seahorses, a differentiated stomach and teeth are lacking (Foster and Vincent, 2004). Hence, no mechanical or acidic pre-digestion occurs prior to intestinal transit, leading intestinal non-esterase lipases to digest dietary lipids.

In our study, differences of non-specific esterase activities among diet treatments were related to an early supply of copepods. In this sense, the low digestibility of the *Artemia* by *H. guttulatus* juveniles may compromise the absorption and accumulation of highly energetic lipid vacuoles. Ontogenetic changes of the specific activity of BHL, OcHL and OIHL could be related both to the digestive tract development (Wardely 2006) and to the dietary shift to *Artemia* nauplii and metanauplii during the period 10-15 DAR. In fact, juveniles fed on Diet A showed higher variations than seahorses fed on Diet M in the non-specific esterase proportions with ontogeny; such variations imply higher energy consumption for different proportion of enzyme synthesis.

Starvation undergoes important metabolic, physiologic and energetic changes that imply a general disruption of the metabolism in *H. guttulatus* juveniles (Planas et al., 2012). Blanco et al. (2011) reported that about 60% of the total energy consumed by starving juveniles from birth to death (at about 5-6 DAR) was catabolised during the first 24 h of life. Hence, protein mobilization seems to play an important role obtaining energy when food is unavailable but probably at low rate than in fed juveniles. We have analyzed enzyme activity levels in juveniles with empty guts but not the contribution of exogenous enzymes from food intake to juvenile digestion. However, there is strong evidence that dietary enzymes are actively involved in larval digestion (Lauff and Hofer, 1984; Munilla-Morán et al., 1990). For example, the importance of exogenous esterases (from rotifers) to lipid digestion of larvae has been reported in turbot, where the contribution of prey to total esterase activity accounted for >95% (Munilla-Morán et al., 1993). Considering the low activities detected for most enzymes analyzed, it is feasible that juvenile *H. guttulatus* digestion might be largely dependent on exogenous feeding during the first days of life, suggesting detrimental effects of starvation periods.

The nutritional status and energetic condition of juveniles are very likely related to their digestion capabilities. Fulton's condition K_F has been used as a criterion to assess fish

condition in advanced stages of development (Ferron and Leggett, 1994) but that it is not adequate to describe the fish condition of early developmental stages at the onset of exogenous feeding (Neilson et al., 1986). In seahorses, however, it has been reported that K_F -values until 5 DAR were consistent with survival, growth and behaviour of *H. guttulatus* juveniles submitted to different temperature regimes and feeding conditions (Planas et al., 2012). In the present study K_F -values until 5 DAR dropped consistently with trypsin enzymatic activities. Afterwards, a progressive recovery in juveniles' condition was noticed from day 10, independently of the diet. At 30 DAR, K_F approached to values of newborn as reported earlier (Planas et al., 2012).

The successful rearing of young fish and the assessment/establishment of adequate feeding regimes will depend in part on the understanding of gut functions and processes. A general description of the enzymatic equipment seems to be insufficient to ascertain the nutritional status and digestive capabilities in early developing seahorses. A combination of morphological, histological and physiological knowledge in seahorse juveniles would be necessary.

5.5. Conclusions

The present study on the ontogeny of the digestive enzymatic equipment in early stages of the long-snouted seahorse *Hippocampus guttulatus* showed that initial enzymatic activities related to digestion processes are largely affected by the feeding regime. Higher enzymatic activities and survivals were observed in seahorse juveniles are fed until 10DAR on a diet supplemented with calanoid copepods. Therefore, the use of a mixed diet containing copepods during the early development of seahorses is recommended. Furthermore, increasing the duration of the feeding on mixed diets might improve physiological processes and juvenile condition of seahorses by reducing ontogenetic changes due to shifts in the dietary regime. Further studies on feeding would be needed for the optimization of the rearing techniques.

CHAPTER 6

Closing the life cycle of the European long-snouted seahorse

Hippocampus guttulatus Cuvier 1829

Closing the life cycle of the European long-snouted seahorse

Hippocampus guttulatus Cuvier 1829

ABSTRACT:

Wild populations of many seahorse species are declining due to several reasons depending on the geographical region considered. Some species, mainly from Asia, are overexploited (Traditional Chinese medicine and aquarium trade) whereas others, such as European species, are suffering the loss of their natural habitats due to anthropogenic effects. Populations of European seahorse species (*Hippocampus guttulatus* and *H. hippocampus*) are also declining even that they are not commercially exploited. The production *ex-situ* of seahorses is a potential tool for the recovery of wild populations and also a way to fulfil aquarium trade needs. Efforts have been made in last years to develop a viable rearing technique for *H. guttulatus*. Until recently, high mortalities were achieved due to the high proportion of juveniles showing swim bladder hyperinflation. However, improvements on several aspects (mainly zoothechnics and feeding) of the rearing technique have significantly enhanced survival and growth rates. As a result, we achieved life cycle closure for the first time in the species by applying a reliable rearing methodology. Eight F2 batches from eight F1 pairs have been raised in captivity until the sub-adult stage. F1 and F2 newborn were rather similar in size (F1 = 15.8 ± 0.9 mm; F2 = 14.9 ± 1.1 mm) and weight (F1 = 6.4 ± 1.0 mg; F2 = 5.5 ± 1.2 mg), but batch size in F1 was higher (486 newborn) than in F2 (178). Mean survivals at day 30 after male's pouch release in F1 batches were higher than in F2 batches (51 ± 25 and 25 ± 15 %, respectively), probably due to the use of different diets in the enrichment of *Artemia* nauplii since most mortalities occurred after the start of feeding on *Artemia* metanauplii. First sexual differentiation in F1 males occurred at the age of 4 months (8.7 mm; 1.4g) whereas the age of first maturation in both males (first batch size = 140 newborn) and females (first clutch release = 465 eggs) was 8 months.

6.1. Introduction

The first serious activities in the artificial rearing of seahorses (*Hippocampus* sp.) were initiated in the 70s - 80s. From them, important advances were further achieved in *H. subelongatus*, *H. abdominalis*, *H. capensis*, *H. fuscus*, *H. barbouri* and *H. kuda* (Lockyear et al., 1997; Wilson and Vincent, 2000; Payne and Rippingale, 2000; Woods, 2000a, 2000b; Job et al., 2002). There were various reasons to undertake the rearing of seahorses. Initially, the main reason was to reduce the pressure of fishing on overexploited wild populations (supply to Traditional Chinese Medicine). Besides this, the increasing importance of seahorses in the aquarium trade also enhanced the research on these flag-ship species. The production of *ex-situ* reared juveniles was considered a potential tool to enhance wild population recovery and to provide the needs of the commercial trade (Prein, 1995; Vincent, 1996). Surprisingly repopulation studies are almost lacking and only one species (*Hippocampus comes*) has been reported to be commercially produced to supply the TCM (FAO, 2014; Koldewey and Martin-Smith, 2010).

Seahorse aquaculture has been strongly dependent on wild population supply (Tlusty, 2002), particularly on pregnant wild-caught males as a source of viable fry to successfully close the life-cycle of the species (Wilson and Vincent, 2000; Hora and Joyeux, 2009; Murugan et al., 2009). Stability on the seahorse trade demand is essential to achieve positive benefits in seahorse aquaculture, switching from wild to cultured animals in order to avoid negative environmental impacts and promoting local socioeconomic development (Job et al., 2002; Martin-Smith and Vincent, 2006; Vincent and Koldewey, 2006). Successful operational aquaculture activities must offer captive bred seahorses cheaper than wild-caught specimens (Vincent, 1996) and rely in a minimum number of wild animals to maintain genetically healthy captive broodstock (Koldewey and Martin-Smith, 2010). Although captive second generations have not been reported (Burhans, 2004), six seahorse species (*H. abdominalis*, *H. kuda*, *H. ingens*, *H. zosterae*, *H. capensis* and *H. whitei*) have been successfully raised up to the adult stage (Wilson and Vincent, 2000; Burhans, 2004; Woods 2000b, 2003b). Currently, difficulties remain for successful closing the life cycle in other seahorse species due to the lack of information on husbandry requirements and management practices (Koldewey and Martin-Smith, 2010; Olivotto et al., 2011).

European seahorse species, *Hippocampus guttulatus* and *H. hippocampus*, are not under fishing pressure but it is know that wild populations are declining due to different

factors, most of them related to effects of anthropogenic origin, including collecting for curious and accidental by-catch. According to censuses carried out in 2000 and 2005, European seahorses are held in 40-50% of European Aquaria (Koldewey, 2005). Until last year, all those seahorses were previously collected in the wild. The European Fish and Aquatic Invertebrate Taxon Advisory Group (FAITAG) initiated Aquatic Sustainability Programmes (ASPs) and prioritized the successfully and repeatedly closure of the life cycle of the two European seahorse species to ensure the welfare of wild populations (Koldewey, 2005). The first attempts to achieve a successful rearing technique for European seahorse species started in 2006 with Proyecto Hippocampus, both for conservative and economical purposes. Since then, significant advances have been made at several stages of the rearing cycle, particularly on breeding (Planas et al., 2008b, 2009a, 2009b, 2010, 2013) and rearing of juveniles (Planas et al., 2012). For the first time, the present study provides the results achieved in the closure of the life cycle of the species *Hippocampus guttulatus*.

6.2. Materials and methods

6.2.1. Broodstock

Wild *Hippocampus guttulatus* adults were hand-caught collected at several locations of the Galician coast (NW Spain) from winter 2010 to summer 2012. Seahorses were *in-situ* weighed and photographed for further length measurements immediately after capture. A total of 60 adult seahorses, comprising 28 females and 32 males (14 of which were pregnant) were transported in isothermal polystyrene boxes to the rearing facilities at the Institute of Marine Research (IIM-CSIC) in Vigo (Spain) and acclimatized for 3 hours by adding 10% seawater and progressive adjustment of temperature. Then, seahorses were tagged by individual nylon collars, transferred to 630L aquaria (Planas et al., 2008; Planas et al., 2012) and maintained in a flow-through system. Seawater was pumped directly from the Atlantic Ocean, mechanically filtered through 5 μ m cartridges and UV treated. Daily renewal of 10-15 % of the total volume was applied. Adult seahorses were maintained under natural photoperiod and temperature conditions by gradually adjusting of temperature, from 15 °C in winter to 19 °C in summer (± 0.5 °C), and photoperiod regime, from 16L:8D in June–July to 10L:14D in December–January (Planas et al., 2010a, 2013). Water quality was checked periodically for NO₂, NO₃ and NH₄/NH₃ content by using Sera Test Kits. Average salinity and pH levels were 38 ± 1 ppt and 8.1 ± 0.1 , respectively. Seahorses were fed *ad libitum* twice daily on enriched adult *Artemia*

and supplemented with wild-caught mysidacea (*Leptomysis* sp. and *Siriella* sp.) or cultivated shrimps (*Palaemonetes varians*) (Blanco et al., 2010, Annex III). *Artemia* enrichment consisted on a mixture of microalgae (*Phaeodactylum tricornutum* and *Isochrysis galbana*), Red Pepper (15mg l⁻¹) (Bernaqua, Belgium) and dried Spirulina (30mg l⁻¹) (Iberfrost, Spain) for at least 12 days. Final additional doses of Red Pepper (80mg l⁻¹) were added daily for at least 3 days. Faeces and uneaten food were siphoned every day before feeding.

Seahorse mating occurred regularly under summertime captive conditions. Males showing advanced pregnancy were isolated in 30L pseudokreisel aquaria (18 ± 1 °C temperature; 16L:8D photoperiod regime) until newborn release.

6.2.2. Rearing system

Newborns were transferred to 30 L pseudokreisel experimental aquaria immediately after male's pouch release (0 DAR) at an average density of approximately 5 seahorses L⁻¹. Pseudokreisel aquaria were operated in a semi-opened recirculation system until summer 2013, when the system was closed as a successful preventive measure against foreign infections. Each rearing unit, comprising 3-6 experimental aquaria, were equipped with a degasifying column, mechanical (up to 20 µm) and biological filters, 36w UV light units and skimmers (Blanco et al., 2014). Seahorse juveniles were reared under a natural-like photoperiod regime (16L:08D) (Blanco et al., 2014). First generation newborns (F1) were used for different experimental purposes and, therefore, different rearing conditions were tested. Cleaning of experimental aquaria was carried out 3-4 times a day (08.00, 11.00, 14.00 and 17.00) to eliminate waste (uneaten food and faeces) and dead juveniles.

From 30 days of age (30 DAR) onwards, seahorse juveniles of the same batch were placed in the same rearing aquaria. F1 juveniles from 2011-2012 batches were raised in pseudokreisel aquaria. Then, juveniles (> 79 DAR) were transferred to 160-180 L aquaria. .

6.2.3. Feeding conditions

From 0 to 10 DAR, seahorses were fed on three different diets:

- Diet A: Juveniles fed solely on *Artemia* nauplii (1 nauplii ml⁻¹)
- Diet M: Juveniles raised on *Artemia* nauplii (1 nauplii ml⁻¹) and *Acartia tonsa* (adult and copepodites, 0.6 copepods ml⁻¹)

- Diet C: Juveniles fed on *Acartia tonsa* (0.6 copepods ml⁻¹) from 0 to 10 DAR and on *Artemia* nauplii (1 nauplii ml⁻¹) from 6 to 10 DAR.

From 11 to 30 DAR, all juveniles were fed on a mixture of *Artemia* nauplii and enriched metanauplii (1:1, 1 *Artemia* ml⁻¹).

From 30 DAR onwards, a diet based on 24h and 48h enriched *Artemia* metanauplii (1:1) was delivered *ad-libitum* for at least 15 days. The average size of the prey was adjusted every two weeks by providing a mixed diet comprising older *Artemia*, supplemented with calanoid copepods *A. tonsa* when available. From 115 DAR onwards, additional wild-caught mysidaceans (*Leptomysis* sp. and *Siriella* sp.), previously stunned with tap-water, were also supplied. After 1 month feeding on live mysids seahorses were progressively and successfully weaned onto frozen mysids.

6.2.4. Prey culture

Artemia cysts were incubated at 28 °C for 20h in 15 L incubators. Freshly hatched nauplii were rinsed and maintained in tap-water for 30 minutes prior to be transferred to 5 L seawater buckets (100 *Artemia* ml⁻¹) for enrichment. *Artemia* nauplii were daily enriched at 26 °C in 5 L buckets with three different enrichment procedures based on the highly unsaturated fatty acid (HUFA) content in the enrichment diet. *Artemia* metanauplii offered to juveniles were enriched on low and intermediate HUFA diets in F1 bathes and intermediate and high HUFA diets in F2 batches.

- Low HUFA: 2 L microalgae mixture (1:1) of *Isochysis galbana* (10⁷ cells ml⁻¹) and *Phaeodactylum tricornutum* (1.6 10⁷ cells ml⁻¹) or 2 L microalgae mixture (1:1:1) of *I. galbana* (10⁷ cells ml⁻¹), *P. tricornutum* (1.6 10⁷ cells ml⁻¹) and *Rhodomonas lens* (16⁷ cells ml⁻¹).
- Intermediate HUFA: 1 L of microalgae *P. tricornutum* (1.6 10⁷ cells ml⁻¹) at 09.00 and 0.3 g dried Spirulina + 0.5 g Red Pepper (Bernaqua) at 18.00.
- High HUFA: 1 L of microalgae *P. tricornutum* (1.6 10⁷ cells ml⁻¹) + 0.25 g dried Spirulina + 0.25 g Red Pepper (Bernaqua) at 09.00, and 0.5 g dried Spirulina + 0.5 g Red Pepper at 18.00.

Calanoid copepods (*Acartia tonsa*) were cultivated at low densities (< 1 adult ml⁻¹) and at 26 °C on 10 L mixtures of the microalgae *I. galbana* (10⁷ cells ml⁻¹) and *R. lens* (16⁷ cells ml⁻¹) in 250 - 500 L tanks.

Enriched *Artemia* was also rinsed and maintained in tap water for 30 minutes prior to be delivered to seahorses. All prey were washed and sieved on different mesh sizes (125 μm for *Artemia* nauplii/metanauplii and 180 μm for copepods) and counted before being offered to seahorses.

6.2.5. Experimental procedure

Behaviour characteristics of juveniles such as age at first holding, colour, courtship and maturation were recorded regularly. Samples seahorses (n= 10-20) for biometrics purposes were taken and anaesthetised with tricaine methanesulfonate (MS-222; 0.1 g L⁻¹), washed with tap water and photographed for standard length (SL) measurements. Then, after water removal, juveniles were individually weighted on a Sartorius microbalance MC210P (\pm 0.01 mg). Juveniles not used for other purposes were awoken and transferred back to their original aquaria. Sampled juveniles were considered for the estimation of final survival.

SL was measured as head + trunk+ tail length (curved measurement) as reported by Lourie et al. (1999). Measurements were made on digital images using an image processing software (NIS Elements, Nikon).

Sexual differentiation and maturation of seahorses was recorded systematically from the moment of first male differentiation within each batch. Seahorses were not sacrificed for internal sexual maturation determination and only the development of male's pouch was used to assess maturity.

Growth rates in seahorse batches from F1 generation were calculated at five different life ages: A) 0-1 month; B) 1-6 months; C); 6-8 months D); 8-12 months and E) 12-16 months (end of study). Additionally, growth rate in F2 (A and B age-groups) was only calculated in the first batch released.

Daily weight-specific growth rates (G; % day⁻¹) were calculated as:

$$G = 100 (e^g - 1)$$

where the instantaneous growth coefficient g is obtained by the following equation

$$g = (\ln W_2 - \ln W_1) / (t_2 - t_1)$$

where W_2 and W_1 are the average seahorse wet weights (mg) on t_2 and t_1 , respectively, being t the time in days.

6.2.6. Data Analysis

Survival differences between F1 and F2 at 30 DAR were tested by One-way ANOVA, as well as differences for *Artemia* metanauplii enrichments (low, intermediate and high HUFA content). Differences in SL between F1 and F2 were analysed by Student's *t*-test, whereas differences in wet weight were tested by the non-parametric Mann-Witney test. SL–WW relationship fit a power growth model from which the allometric coefficient was obtained. Student's *t*-test was used to detect differences in batch size (newborn released per batch) in F1 and F2 generations. All analyses used $\alpha = 0.05$.

6.3. Results

A total number of 8 batches of F1 newborn were released in 2011 and 2012 from 5 males and, at least, 7 females (genetic identification of female in one batch was not carried out) (Table 1).

Table 1. Characteristics of F1 (Origin of F2) and F2 newborn batches and survival at 30 DAR. Normal: Normally developed newborn.

Batch	Year	Total	Normal (%)	WW (mg)	SL (mm)	Survival 30 DAR (%)
F1_1	2011	666	98	4.7 ± 0.3	14.6 ± 0.8	55
F1_2	2011	505	84	5.9 ± 0.4	16.0 ± 0.6	83
F1_3	2012	347	65	7.9 ± 0.9	16.2 ± 1.0	41
F1_4	2012	439	100	5.6 ± 0.4	14.8 ± 0.3	34
F1_5	2012	286	100	6.5 ± 0.6	16.4 ± 1.1	36
F1_6	2012	658	100	6.4 ± 0.2	16.1 ± 0.5	92
F1_7	2012	477	97	6.0 ± 0.4	16.2 ± 0.6	49
F1_8	2012	509	100	6.3 ± 0.4	15.8 ± 0.4	17
Mean		486 ± 133	93 ± 13	6.4 ± 1.0	15.8 ± 0.9	51 ± 25
F2_1	2013	385	72	4.8 ± 0.3	14.3 ± 0.6	20
F2_2	2013	140	100	4.7 ± 0.7	14.3 ± 1.0	44
F2_3	2013	24	100	5.3 ± 0.5	14.7 ± 0.5	22
F2_4	2013	81	100	-	-	11
F2_5	2013	108	100	7.2 ± 1.3	14.5 ± 0.6	10
F2_6	2013	288	100	5.1 ± 0.3	15.0 ± 0.6	40
F2_7	2013	210	100	5.6 ± 0.5	16.1 ± 0.5	10
F2_8	2013	198	100	5.6 ± 1.0	15.5 ± 1.4	41
Mean		179 ± 117	97 ± 10	5.5 ± 1.2	14.9 ± 1.1	25 ± 15

Two batches were released in 2011 from the same male from mating two different females. Up to three batches from the six released in 2012 belonged to the same male, which mated at least two different females (female not identified in one batch). Mean SL and WW of parental F0 males were 190 ± 17 mm and 19.7 ± 5.6 g, respectively, while identified parental F0 females measured 199 ± 11 mm and weighted 20.3 ± 2.6 g. No significant differences were found between F0 males and F0 females for either WW (t-test= 1.08, df= 9, $p > 0.05$) nor SL (t-test= 0.25, df= 9, $p > 0.05$).

First generation (F1) average batch size was 486 newborn (range 286 - 666), which was significantly higher than that in F2 (178 ± 115) generation (t-test= 5.07, df= 14, $p < 0.05$). The proportion of normally developed newborn was similar in F1 ($93 \pm 13\%$) and F2 ($97 \pm 10\%$) generations. Healthy newborn were free swimmers, active feeders and showed a clear brown pigmentation. At birth, both weight and length in F1 newborn (6.4 ± 1.0 mm; 15.8 ± 0.9 mg) were slightly higher than in F2 newborn (5.5 ± 1.2 mm; 14.9 ± 1.1 g), although no significant differences were found (t-test= 1.922, df= 11.81, $p > 0.05$).

Average survivals at 30 DAR in F1 and F2 juveniles were 51 ± 25 (11 - 94%) and $25 \pm 15\%$ (10-44%), respectively ($F_{14,1} = 10.18$, $p < 0.01$) (Table 1; Figure 1). The first differences among F1 and F2 batch survivals were noticed in 18-20 DAR juveniles, one week after the start of feeding on *Artemia* nauplii and metanauplii. Since then, higher mortalities were recorded in F2 batches. Within the same generation, no significant differences were found in survivals at 30 DAR among diet treatments (*Artemia* metanauplii enrichment). However, the average survival in 30 DAR juveniles fed on metanauplii enriched on the intermediate HUFA diet was similar in F1 and F2 batches ($F_{19,1} = 1.12$, $p = 0.31$). In F1 seahorses, peaks of mortality (up to 80%) were recorded from 40 to 50 DAR.

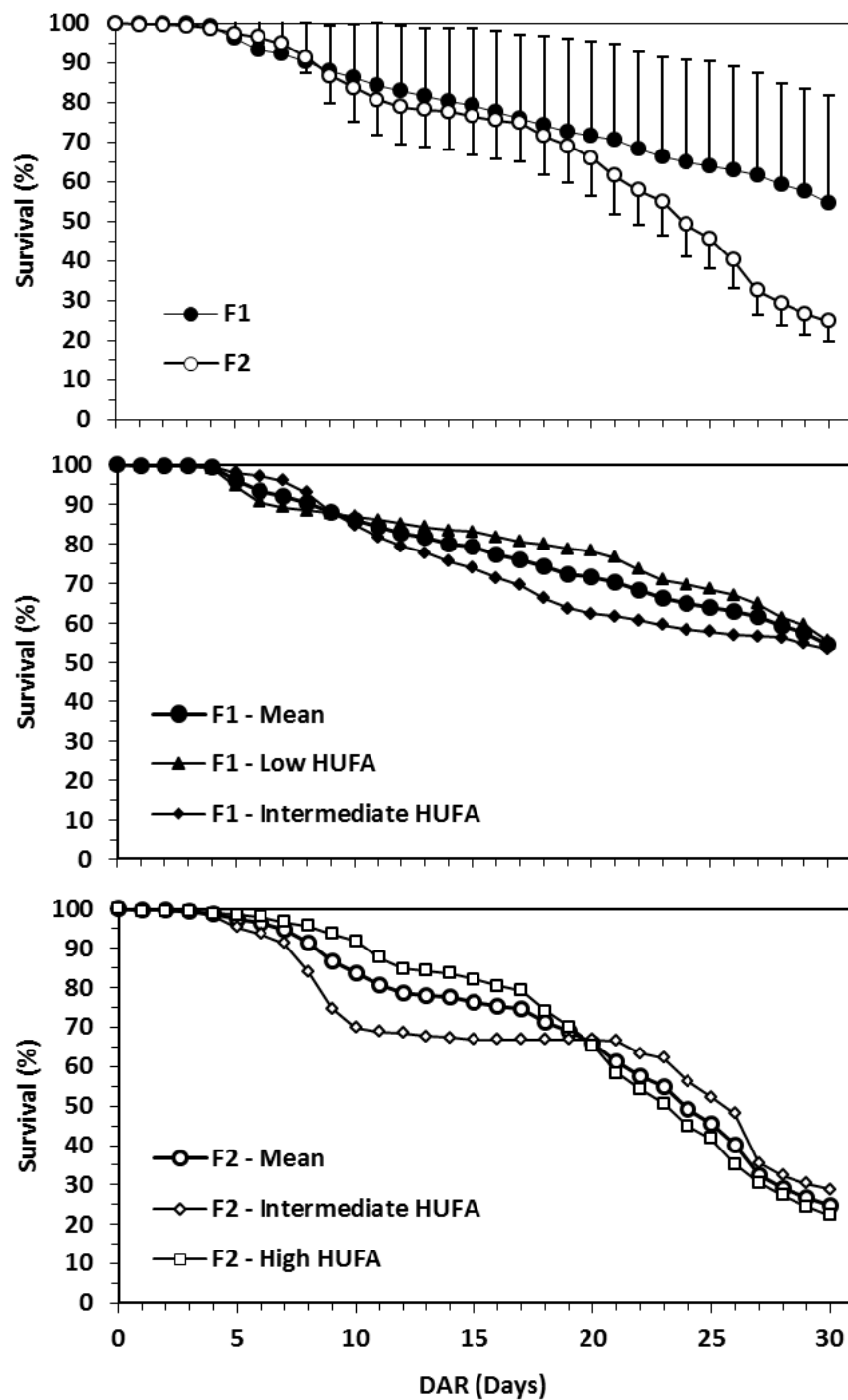

Figure 1. Survival rates (%) from release (0 DAR) to 30 DAR of F1 and F2 juveniles fed on different HUFA enriched *Artemia metanauplii*.

Standard length and wet weight relationships ($R^2 = 0.994$) of F1 generation with development are provided in Figure 2 and Table 2. The coefficient of allometry (b) for pooled stages was 3.14 but increased with age (2.80 in juveniles up to 30 DAR, 3.11 in sexually differentiated juveniles and 3.48 in firstly matured seahorses).

Table 2 Standard length and wet weight at different developmental stages of F1 and F2 seahorses. SL and weight in F0 generation was 19 ± 1.7 cm (range 18.5–21.7) and 20 ± 6 g (12–27) in males and 19.9 ± 1.1 (16.7–20.9) and 20 ± 3 (18–24) in females.

	Age	SL (mm)	WW	Diet
F1	Newborn	15.8 ± 0.9	6.4 ± 1.0 mg	<i>Artemia</i> nauplii + copepods
F1	1 month	32.3 ± 5.8	51.7 ± 29.0 mg	<i>Artemia</i> (nauplii + metanauplii)
F1	6 months	119.5 ± 6.4	2.9 ± 0.9 g	Enriched <i>Artemia</i> + live mysids
F1	8 months	108.0 ± 12.0	2.7 ± 1.0 g	Adult enriched <i>Artemia</i> + frozen/live mysids
F1	12 months	160.0 ± 10.0	9.2 ± 1.5 g	Adult enriched <i>Artemia</i> + frozen/live mysids
F1	16 months	184.1 ± 14.2	16.6 ± 4.4 g	Adult enriched <i>Artemia</i> + frozen/live mysids
F2	Newborn	14.9 ± 1.1	5.5 ± 1.2 mg	<i>Artemia</i> nauplii + copepods
F2	1 month	31.1 ± 4.3	46.7 ± 20.5 mg	<i>Artemia</i> (nauplii + metanauplii)
F2	6 months	124.8 ± 11.5	4.4 ± 0.9 g	Enriched <i>Artemia</i> + live mysids

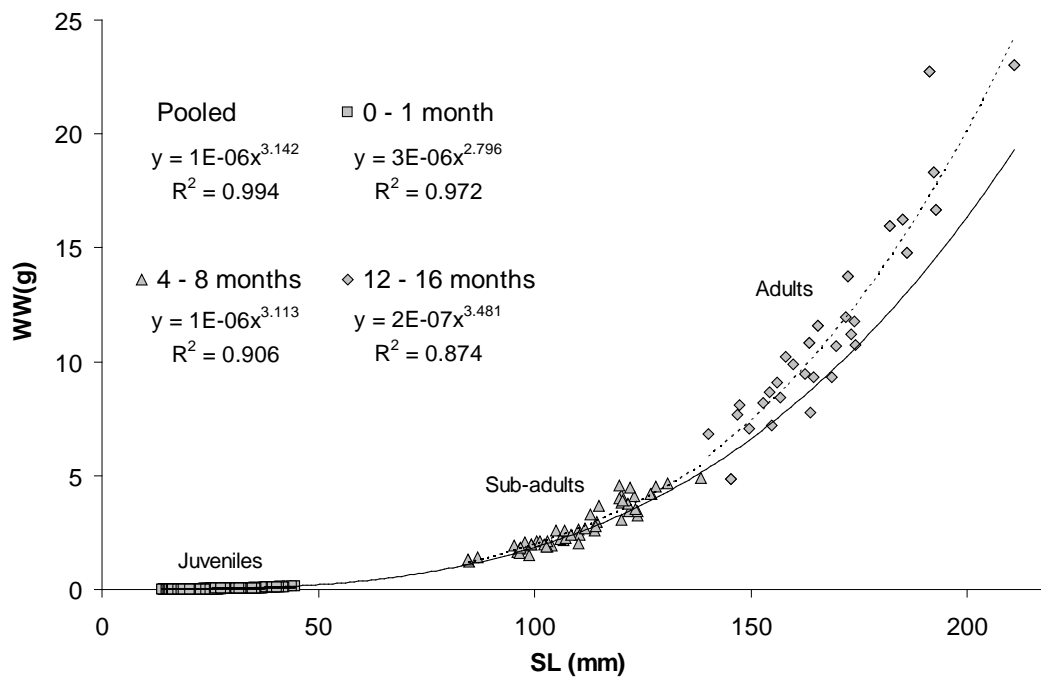

Figure 2. Standard length (SL) and wet weight (WW) relationships in F1 seahorse juveniles at different age intervals (0-1, 4–8 and 12–16 months). Continuous line: Pooled groups. Dotted line: adjustments for single groups.

Daily growth rates were higher during the first month of life ($G = 7.2\%$), decreasing progressively until the end of the study at month 16 ($G = 0.6\%$), following a negative exponential curve ($G = 6.898 e^{-0.189 \text{ DAR}}$, $R^2 = 0.982$) (Figure 3). The lowest G values were achieved from 6 to 8 months old seahorses ($G = -0.1\%$). Initial daily growth rates in F1 and F2 juveniles up to month 6 were almost identical.

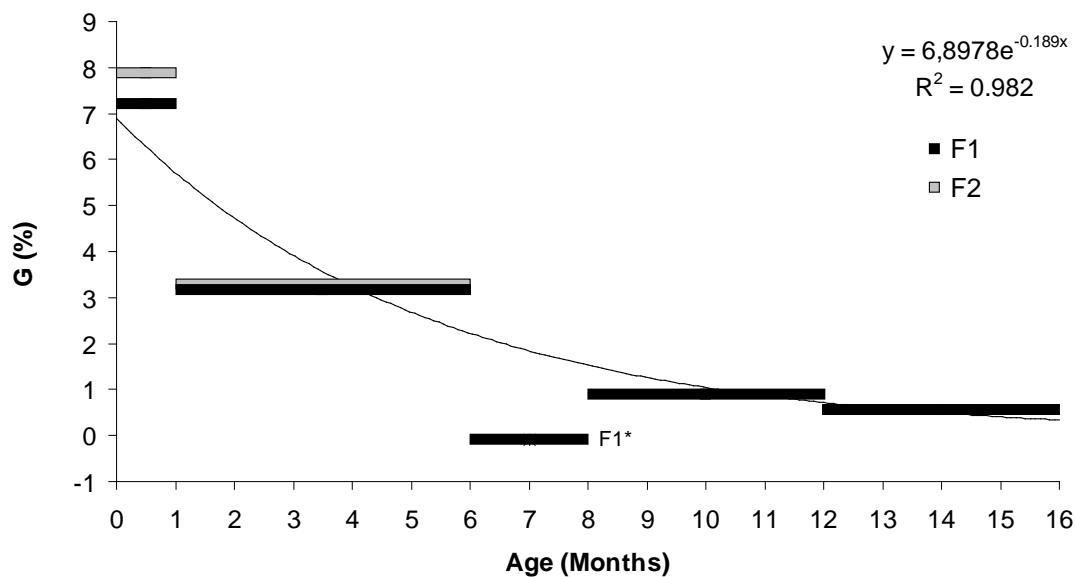

Figure 3. Specific growth rates (G) in F1 seahorses (Black) and F2 juveniles (grey) in the periods 0-1, 1-6, 6-8, 8-12 and 12-16 months of age. F1* (excluded in equation fitting) shows G (%) in maturing juveniles from 6 to 8 months.

Anecdotally, 2 newborn remained holdfasted for 2 h immediately after male's pouch release and 6 juveniles holdfasted at 4-6 DAR, but most juveniles started to holdfast for some time from 10 DAR. Juveniles holdfast during most lightning period of the day from day 15-20 onwards.

The first sexually differentiated male (pouch visible) was recorded at 4 months of age (124 DAR) (8.7 mm, 1.4 g), whereas courtship activities were firstly recorded in 214 – 221 DAR seahorses. The first female maturation (first eggs release) occurred between 266 – 273 DAR (clutch size = 365 eggs). The eggs from that clutch were $2.54 \pm 0.67 \text{ mm}^3$ in volume and weighted $643 \pm 143 \mu\text{g DW egg}^{-1}$. The first batch of newborn produced by F1 stock was recorded in January 2013 (male not identified) in an aquarium comprising 15 months old seahorses and the youngest pregnant male (F1) recorded was 8 months old (batch size = 140 newborn: $4.7 \pm 0.7 \text{ mg WW}$; $14.3 \pm 1 \text{ mm SL}$). All F2 batches were successfully reared up to adult stage.

6.4. Discussion

This is the first study reporting the closure of the life cycle in the European long-snouted seahorse *Hippocampus guttulatus*. Since early studies carried out on this species in late 2000 and the improvements achieved in the following years, this study demonstrate that a rearing technique is already available for this European seahorse species. One of the most

important advancements concerned the enhancement of newborn quality and the reduction in the presence of immature or malformed juveniles (Planas et al., 2009b; Olivotto et al., 2011). A proportion of 3-7% of abnormal/immature newborn in F1 and F2 batches can be considered clearly satisfactory.

A wide range of survivals and a variety of feeding and zoothechnical conditions has been reported in the early rearing of *H. guttulatus* (Faleiro et al., 2008; Palma et al., 2008; Planas et al., 2008a, 2008b, 2009a, 2009b, 2010). As for most seahorse species, *Artemia* has been used as the main prey in the feeding schemes (Faleiro, 2011; Palma et al., 2011; Olivotto et al., 2011). Generally, *Artemia* does not fulfil the best feeding needs for seahorse juveniles and consequently the resulting survivals were unsatisfactory. Survivals and growth rates increased notoriously with the incorporation of copepods in the diet of early developing juveniles and with the establishment of adequate rearing conditions (Payne and Rippingale 2000; Olivotto et al.; 2008; Blanco et al., 2014; Blanco and Planas 2014a, 2014b). Survival rates as high as 90% can be reached at 30 DAR by adjusting properly temperature level (about 19°C) and feeding regime (Blanco et al., 2011b, 2013; Planas et al., 2012; Blanco and Planas, 2014a) and using the adequate aquarium type (pseudoKreisel aquarium) (Blanco et al., 2014). Those survivals are significantly higher than those achieved when using *Artemia* as the unique prey in the diet (20%) (Faleiro, 2011; Palma et al., 2011).

The results included in this study were obtained from rearing trials carried out under different conditions, particularly on the type of enrichment used in *Artemia*. The type of enrichment seems to have effects on the mortality patterns during the early rearing of juveniles, both when comparing F1 and F2 batches and also when comparing the enrichment treatments for a given generation of juveniles. Those effects deserve further investigation since the HUFA requirements in juveniles of *H. guttulatus* have been scarcely investigated (Faleiro and Narciso, 2010, 2013). In spite of these, differences in average survival rates between F1 and F2 batches were only noticeable in >20 DAR juveniles. This finding suggests that differences in mortalities were very likely due to causes other than newborn quality.

Broodstock diet and progenitors size have large influence on the quality of seahorse eggs/ juveniles, namely initial size, growth rate and survival of juveniles (Dzyuba et al., 2006; Lin et al., 2008, Otero-Ferrer et al 2009; Planas et al., 2010a). Although the parents of F1 and F2 were fed on the same diet and their average size was similar, average batch size and newborn size/weight were smaller in F2. However, the brood size in F2 (179 newborn) was

slightly smaller than in wild adult males from Ria Formosa (214 newborn) (Curtis, 2007). In spite of the differences between F1 and F2 batches, juveniles grew and, to a lesser extent, survived similarly until 20-30 DAR. The release of lower numbers of young by newly mature males (F2) might be related to their first maturity status as pointed out in *H. kuda* (Dzyuba et al., 2006). Similar findings were also reported in *H. trimaculatus*, in which the batch size was clearly higher in F1 (495 newborn) than in F2 males (65 newborn) (Murugan et al., 2009).

Undoubtedly, another important advance for closing the life cycle in *H. guttulatus* was the improvement in breeding and the availability of artificial techniques for shifting the breeding season without affecting newborn quality (Planas et al., 2013). Until recently, the main constrain in the rearing of seahorses was its dependency on pregnant wild-caught males (Wilson and Vincent, 2000), which has important negative effects on wild populations (Wilson and Vincent, 2000; Tlusty, 2002; Job et al., 2006; Murugan et al., 2009). Although successful production from successive generations of adult seahorses have been achieved for some species and thousands of individuals have been supplied all over the world for the aquarium trade (Woods, 2000a, 2003; Burhans, 2004), that is not the general rule since attempts for closing the life-cycle have been generally achieved from the rearing of a unique batch (Wilson and Vincent, 2000, Hora and Joyeux, 2009; Murugan et al., 2009). Even though it is known that seahorse life cycle has been closed for several seahorse species (Koldewey and Martin-Smith, 2010), records reporting the achievement of second generations and some characteristics (brood size, age at first maturation) in captivity are only available for *H. trimaculatus* (Murugan et al., 2009), *H. reidi* (Hora and Joyeux, 2009), *H. fuscus* and *H. barbouri* (Wilson and Vincent, 2000). Sexual differentiation of *H. kuda* and *H. subelongatus* juveniles has been reached in captivity but data on F2 are lacking (Wilson and Vincent, 2000; Job et al., 2002, Payne and Rippingale, 2000).

Vulnerability of young seahorses to diseases has been well documented (Wilson and Vincent, 2000; Woods, 2000a). Huge mortalities in F1 juveniles from days 40-50 could be related with suboptimal nutritional status and, more feasible, to pathogens (Ofelio et al., 2013). In spite of that constrain, a large number of F2 survivors reached the adult stage. Those seahorses were easily weaned onto frozen wild-caught mysids and subsequently fed on commercially-frozen mysids, which is of main interest for mass-scale of seahorses (Woods 2003a, 2003b; Lin et al., 2009; Murugan et al., 2009). A decrease in growth rates due to a decrease of both feeding rates and feeding frequency has been related with weaning of

juveniles into frozen food (Lin et al., 2009) and with the onset of sexual maturation in *H. abdominalis* (Woods, 2000) and *H. reidi* (Hora and Joyeux, 2009). In the present study, both events occurred and resulted in a decrease of growth rates in that period.

Closing the life cycle in *H. guttulatus* opens the door to the introduction of *H. guttulatus* into the aquarium trade and, more importantly, will allow the production of the necessary individuals to ensure future plans for the recovery of wild populations (reinforcement or repopulation plans) under adequate management of breeders in order to preserve genetic diversity and avoid inbreeding in conservation breeding programs (Caballero et al., 2010; López et al., 2012).

6.5. Conclusions

Second generation (F2) juveniles of the European long-snouted seahorse *Hippocampus guttulatus* were produced in captivity by improving several stages of the rearing technique. Even though some mortality episodes need to be conveniently addressed in the future, reasonably high survivals can be achieved. The rearing procedure would be helpful in future conservation breeding actions for the species.

4. SUMMARY

Preliminary studies on wild populations of the European long-snouted seahorse *Hippocampus guttulatus* in the Galician coast reported declines and fragmentation of populations, with very low densities although this species is not a target in Galician fisheries. Habitat loss of anthropogenic origin and incidental bycatch by other commercial exploitation activities were suggested as the main threat for this species in NW Spain. Recent genetic studies suggested that wild populations in Galicia might be under a long-term demographic reduction and a short-term demographic expansion, which have been related to a continuous and progressive habitat alteration scenario (López 2011).

The production *ex-situ* of juveniles has been considered a potential tool for further reinforcement of wild populations. A research project (Proyecto Hippocampus) was undertaken to achieve a rearing methodology for the species. The projects started in 2007 and one adult was obtained in the following year for the first time from captive mating. After the establishment of adequate but still not optimized breeding conditions (Planas et al., 2008), main efforts were directed towards the rearing of juveniles, the reduction of newborn abnormalities and the improvement of mating and newborn quality. Most studies carried out in this Thesis correspond to the former topic.

The first step in the rearing of a species is the establishment of rearing facilities and broodstock. The broodstock aquaria designed in 2007 at IIM facilities (Planas et al., 2008) performed successfully although some modifications were further applied, mainly related to lightening and water circulation, including the establishment of an under gravel filter and a sandy bottom. Initially, the breeders were fed exclusively on adult enriched *Artemia*, but other prey (*Palaemon varians* and mysidaceans *Leptomysis* sp. and *Siriella* sp.) were incorporated alive as diet supplement. Changes made on the enrichment procedure for adult *Artemia* and the incorporation of other prey into the diet resulted in the enhancement of mating, the production of higher quality newborn and a huge reduction in the presence of abnormal or immature newborn (Olivotto et al., 2011).

It has been reported that feeding adult *H. guttulatus* on frozen shrimp (*Palaemonetes varians*) and mysids (*Mesopodopsis slabberi*) enhance growth rates (Palma et al., 2008), though breeding performance was not studied. Also, Faleiro (2008) pointed out smaller size in newborn from captive breeders fed on frozen *Artemia* and mysids (255 newborn per batch; 14mm; 2.7mg) when compared to newborn from wild seahorses in Ria Formosa (Portugal) (426 newborn per batch; 15mm; 3.7 mg). Conversely, Planas et al. (2010, 2013) reported that

the average size and clutch size of eggs produced by females in captivity at IIM were higher than in the wild. Also, the analyses of the data from this Thesis showed that batch size of healthy newborn from pregnant wild males (323 ± 148 newborn; range 128 - 593) were slightly lower than those from captive males (405 ± 178 newborn; range: 104-791) while size/weight of newborns was almost identical (15 ± 1 mm; 6 ± 1 mg and 15 ± 1 mm; 5 ± 1 mg for wild and captive pregnancies, respectively). Additionally, the proportion of abnormal newborn in batches released by wild and captive breeders (fed on *Artemia* supplemented with mysids) was similar (10 and 6%, respectively). Therefore, the discrepancies arisen from the available data need to be conveniently addressed in further studies.

Some aspects of the breeding and husbandry of adult seahorses have been addressed recently. Among others, studies carried out on preference of adults for holdfast structures (Correia, 2013), breeding performance and social behavior under different sex ratio conditions (Faleiro, 2008; Planas, 2008, 2009) or those related with the effect of temperature and photoperiod regimes on female maturation or with the artificial manipulation of the breeding season are noteworthy (Planas et al., 2010, 2013).

Until recently, the information available on the early rearing of *H. guttulatus* juveniles was certainly almost lacking. In the period 2009-2013, few studies focused on the rearing of newborn from wild pregnant males reported low survivals ($\leq 25\%$) in juveniles fed on *Artemia* nauplii at 22-25°C (Faleiro 2013, Palma 2011). However, significant improvements were made by enhancing the rearing technique at different levels, namely zootechnics, physical factors and feeding.

1) Zootechnics

One of the pivotal aspects in the rearing of seahorses concerns the type and design of the aquaria. Conversely to other marine fish species, the rearing of juveniles in some seahorse species has been carried out in traditional or modified Kreisel aquaria (Gomezjurado, 2005; Gomezjurado and Gardner, 2005; Martínez et al., 2005, Burhans, 2004). The main reason for that was based on the tendency of young seahorse juveniles to keep attracted by water surface, resulting in the further hypertrophy of the swim bladder (swim bladder hyperinflation syndrome) and death of affected fish. The design and shape of the aquaria, together with other factors, has great incidence in the water movement and turbulence of the rearing media. Kreisel-type aquaria have the advantage over most conventional rearing aquaria of improving water movement (circular water movement) so that juveniles distribute evenly and, to a

certain level, are impeded to aggregate and remain near water surface. This hypothesis was confirmed in *H. guttulatus* juveniles by the comparative study (Chapter 1) carried out in three different aquaria types (rectangular, spherical and pseudoKreisel) designed at our laboratory. Certainly, the use of the pseudoKreisel aquaria increased average juvenile survivals at 30 DAR from 16-22% (rectangular and spherical aquaria) up to 69%.

2) Physical factors

a) Aeration level

Swim bladder disorders have been related with fish access to water surface. The presence of stagnant areas at or near water surface is highly undesirable since it would prompt the juveniles to be trapped there, and ingest air in excess. Thus, an adequate aeration level together with a satisfactory aquarium design and water inlet placement resulted rather decisive in the final cycling movement of the water. Indeed, average survivals in 30 DAR juveniles reared under a strong aeration level were 3-folds higher than those in weakly aerated aquaria (41 and 13%, respectively) when fed on *Artemia* (Chapters 1 and 4). With respect to zootechnical issues, survival enhancement would rely on the partial contribution, in decreasing order of importance, of aquarium design, aeration level and water inlet placement.

b) Photoperiod

The combined effect of positive phototaxis of prey and seahorse juveniles during the light phase of a day-night rearing cycle and the juvenile inactivity during the dark phase of the cycle was thought to promote overcrowding at the water surface. Contrary to what was expected, the application of a continuous light regime (24h light and 0h darkness) or a day-night photoperiod (16L:8D) did not affect survival nor growth rates of young seahorses (Chapter 1). The results are in agreement with those reported by Martínez-Cardenas and Purser (2012) in *H. adbominalis*.

c) Temperature

Temperature is very likely one of the most important physical factors involved in fish development. The study on growth and survival of the temperate seahorse *H. guttulatus* was performed at three temperatures (15, 18 and 21°C) within the range of the temperatures commonly recorded in the Galician coast (Chapter 2). Suboptimal development of seahorse juveniles was found at water temperature as low as 15°C. Conversely, high growth rates and survival rates were recorded in juveniles reared at 18°C (G = 8% and 86% survival 30 DAR

juveniles, respectively) and 21 °C ($G = 11\%$ and $S_{30} = 81\%$, respectively). These results are in agreement with what was expected for a temperate species whose planktonic juveniles are released during the warm season, when water surface temperatures in Galician coasts average 19°C (Arbones et al., 2008; www.intecmar.org). The Northern distribution limit of *H. guttulatus* in Europe seems to be related with the threshold temperature ($T_o = 13.1$ °C) for the species, at which development is theoretically arrested.

It was demonstrated, within a viable temperature range, the suitability of effective day degrees (D_{eff}°) as a temperature-independent scale to quantify growth in feeding juveniles but not under starving conditions. Accordingly, growth models for single temperatures in the range 14 – 26 °C were constructed. From a practical point of view, temperatures of 19-20 °C are recommended for the rearing of this species in captivity.

3) Feeding

a) Feeding schedule

Traditionally, the early rearing of marine fish in general and seahorses in particular has relied on *Artemia* sp. and rotifers as first prey. The study focused on prey preference (rotifers, *Artemia* and copepods) (Chapter 3) demonstrated that rotifers were systematically rejected at all developmental stages and that copepods and *Artemia* nauplii were actively hunted since newborn release. Preference of copepods over *Artemia* nauplii extended from 3 to 15 DAR.

The presence of undigested and frequently still alive *Artemia* nauplii in feces from very young juveniles was accompanied by low growth rates, high mortalities and weakness of juveniles. The incorporation of copepods (*Acartia tonsa*) in the early diet of juveniles for 10 days significantly enhanced growth and survival ($G = 9\%$ and 66% survival in 30 DAR juveniles, respectively), especially when supplied as the sole prey from 0 to 5 DAR ($G = 10\%$ and 76% survival at 30 DAR, respectively) (Chapter 4).

The results indicate the convenience of feeding juveniles on *Artemia* nauplii and copepods from 0 to 10 DAR or only copepods until 5 DAR. The rearing performance would be potentially enhanced by extending copepods supply at least up to 15 DAR.

The study on mouth biometrics showed that mouth development in juveniles was accomplished by growth of both upper and lower jaws, whose sizes were linearly correlated with juvenile length, whereas mouth width (MW) and height (MH) grew exponentially with

respect to juvenile size. In addition, MW was found to be correlated to MH so that the transversal section of the mouth increased linearly with juvenile age and length. Considering the results on prey selection, mouth biometrics and the finding that mouth area seems to be the limiting factor in prey selection, it is very likely that juveniles would be able to ingest prey much bigger than those provided in our study (168 – 978 μm in length and 85 – 322 μm in width). From the overall results achieved, a tentative feeding schedule has been proposed to successfully feed *H. guttulatus* juveniles on the copepod *Acartia tonsa* and *Artemia* nauplii from 0 to 30 DAR.

c) Digestive capacity

First exogenous feeding in newborn occurs immediately after male's pouch release. The appearance of undigested *Artemia* nauplii in feces at early development stages of *H. guttulatus* was hypothesized to be due to a limited digestive capacity and/or to a reduced intestinal transit of prey. Conversely, the high degree of digestion of copepods in feces from seahorse newborn indicated that copepods digestion was more efficient than for *Artemia* nauplii in young juveniles, resulting in higher growth and survival rates. The analyses on the activity of several digestive enzymes (Chapter 5) reported a reduced digestive capacity in 0-15 DAR juveniles, though higher enzymatic activities (and survivals) were observed in seahorse juveniles fed until 10 DAR on a diet supplemented with calanoid copepods. Particularly noteworthy was the low activity recorded for chitinase, which could explain the low digestion of *Artemia* during the first days of life. The presence of copepods in the early diet of juveniles seemed to enhance digestion capabilities in further developmental stages.

The whole information arisen from this Thesis has largely increased the previous limited knowledge on the rearing of *Hippocampus guttulatus* juveniles. The results on the effect of different factors potentially related to rearing success have permitted the establishment of a feasible and successful rearing methodology. Although it was demonstrated that all studied factors affected the rearing success to some extent, some of them must be considered particularly essential for growth and survival enhancement. The incorporation of copepods to the early feeding regime, the establishment of an optimal temperature level (19°C) and the application of strong aerations (with an appropriate placement of the water inlet) in pseudoKreisel aquaria resulted in i) a huge increase in both

survival (up to 89%) and growth rates, ii) a low incidence of swim bladder disorders, and iii) the production of viable F2 breeders.

Maximizing survivals and growth in young fry are of main importance in future commercial endeavors. Some disease problems with unknown origin have been faced in juveniles from 40 to 60 DAR, prior to sexual differentiation (Chapter 6). The study of those diseases and the enhancement of survival at that stage will be essential to ensure a profitable production of high quality seahorses. The use of probiotics and larger copepod species, among other measures to be undertaken, would probably improve the rearing at more advanced developmental stages. Further research is needed to conveniently address those non-limiting constrains.

Closing the life cycle of *Hippocampus guttulatus* and the availability of a novel and successful rearing technique are significant for knowledge but also for society and the conservation of marine biodiversity. From an economical point of view, this species, as all seahorse species, has an important added-value to aquarium trade. Also, due to their acceptance and attractiveness, seahorses are a powerful tool for educational and sensibilization purposes against biodiversity loss and for conservation of Seas and Oceans. However, the main objective of Proyecto Hippocampus, in which this Thesis was integrated, is the recovery of natural population of *H. guttulatus*, which will be only possible if i) the causes of detrimental anthropogenic effects on the coasts are properly addressed, ii) wild seahorses populations are reinforced based on incomes from *ex-situ* produced individuals and, iii) adequate conservation programs and protection plans are put into practice.

5. CONCLUSIONS

1. The type of aquarium had a significant effect in the early rearing of *Hippocampus guttulatus* juveniles. Modified pseudoKreisel aquaria performed notoriously better than traditional aquaria, including spherical and rectangular shapes. The high survivals achieved in pseudoKreisel aquaria were mainly related with the water circulation pattern and the resulting low proportion of juveniles showing swim bladder hyperinflation at early development.
2. The first study carried out in seahorses about the effect of physical factors such as aeration and photoperiod demonstrated a significant effect of the former in the rearing success. Strong aeration intensities i) improved the even distribution of juveniles in the aquaria, ii) diminished the appearance of swim bladder hyperinflation by avoiding the over-exposition of seahorses to water surface, and iii) increased survivals when compared to weak aeration levels. The effect of aeration level on survival and growth rates were especially evident in juveniles fed on suboptimal diets (*Artemia*).
3. Similar growth and survivals were achieved in juveniles submitted to natural (16h Light: 8h Dark) or extended (24h Light: 0h Dark) photoperiod, though the use of a natural-like photoperiod (16L:8D) is recommended.
4. It was demonstrated that temperature is one of the key factors in the rearing of *H. guttulatus* juveniles. Within the range 15 - 21 °C, juveniles performed significantly better at 21 °C. However, rearing at 19 - 20 °C is recommended to reduce the potential appearance of associated infectious diseases.
5. For the first time in poikilotherm fish, the use of effective day degrees (D_{eff}°) as a temperature-independent growth scale was successfully applied to feeding *H. guttulatus* juveniles. As a result, a unique mathematical model was obtained to predict growth of juveniles at temperatures from 14 to 26 °C.

6. It was hypothesized that the Northern limit of the geographical distribution of *H. guttulatus* in the Atlantic European coasts is determined by the threshold temperature ($T_0 = 13.1 \pm 0.9^\circ\text{C}$) at which growth is arrested.
7. Juveniles showed qualitative and quantitative preference for calanoid copepods *Acartia tonsa* until 15 DAR and for *Artemia* nauplii afterwards. Conversely, rotifers were systematically rejected.
8. The first study carried out in seahorses on mouth development in juveniles showed that juvenile length was exponentially correlated with mouth width and mouth height and that mouth area increased linearly with age and length of juveniles.
9. Mouth biometrics and gut content analyses showed a preference for large copepods over naupliar and copepodite stages, suggesting that juveniles are able to ingest prey much larger than those provided.
10. The use of calanoid copepods until at least 10 DAR is highly recommended. The incorporation of the copepod *Acartia tonsa* in the feeding scheme of juveniles, as unique prey from 0 to 5 DAR and/or supplementing *Artemia* nauplii for at least 10 days (10 DAR), resulted in a significant enhancement of growth and survival.
11. The digestive enzymatic activities in seahorse juveniles were low in all the digestive enzymes assayed but the use of copepods improved to a certain limit the digestive capabilities of juveniles from 15 DAR onwards, resulting in higher survivals. The presence of poorly digested *Artemia* nauplii in faeces of early developing juveniles might be explained by the almost lacking chitinase activity.
12. From the whole results achieved, a feasible and rather reproducible methodology is proposed for the early rearing of *Hippocampus guttulatus* juveniles up to 1 month of age. The

success of the technique is based on the use of modified pseudoKreisel aquaria and the application of the following rearing conditions: strong aeration, temperatures of 18-20 °C and, to a lesser extent, natural photoperiod regimes (16L:8D).

13. The proposed rearing technique is also based on the use of a feeding scheme based on the delivery of the calanoid copepod *A. tonsa* for at least 5 days (0-5 DAR), a mixture of *A. tonsa* and *Artemia* nauplii from 6 to 10 DAR, and *Artemia* nauplii and metanauplii from 11 to 30 DAR.

14. Closing the life cycle of the long-snouted seahorse *Hippocampus guttulatus* in captivity will be useful in future conservation actions for the recovery of wild populations and also, from an economical point of view, in seahorse trade.

6. REFERENCES

- Ajiboye, O., Yakubu, A., Adams, T., Olaji, E., Nwogu, N., 2011. A review of the use of copepods in marine fish larviculture. *Reviews in Fish Biology and Fisheries*. 21, 225-246.
- Alcaide, E., Gil-Sanz, C., Sanjuan, E., Esteve, D., Amaro, C., Silveira, L., 2001. *Vibrio harveyi* causes disease in seahorse, *Hippocampus* sp. *Journal of Fish Diseases*. 24, 311-313.
- Alliot, E., Pastoreaud, A., Trelu, J., 1980. Evolution des activités enzymatiques dans le tractus digestif au cours de la vie larvaire de la Sole. Variations des protéinogrammes et des zymogrammes. *Biochemical Systematics and Ecology* 8, 441-445
- Álvarez, J.P., Blanco, A., Silva, C. & Planas, M., 2009. Proximate biochemical composition and enzymatic activities in eggs of farmed seahorses *Hippocampus guttulatus* and *H. hippocampus* (Project Hippocampus). World Aquaculture Society, 25-29 May 2009, Veracruz (México).
- Anderson, P.A., Petty, B.D., 2013. Mixed metazoan and bacterial infection of the gas bladder of the lined seahorse: A case report. *Journal of aquatic animal health*. 25, 42-52.
- Anil, M., Kakati, V., Ganga, U., Zacharia, S., 1999. Larval rearing of seahorse *Hippocampus kuda* under laboratory conditions. Marine Fisheries Information Service, Technical and Extension Series. 162, 23-25.
- Anto, J., Majoris, J., Turingan, R.G., 2009. Prey selection and functional morphology through ontogeny of *Amphiprion clarkii* with a congeneric comparison. *Journal of Fish Biology*. 75, 575-590.
- Arbones, B., Castro, C.G., Alonso-Pérez, F., Figueiras, F.G., 2008. Phytoplankton size structure and water column metabolic balance in a coastal upwelling system: the Ría de Vigo, NW Iberia. *Aquatic Microbial Ecology*. 50, 169 -179.
- Aurélio, M., Faleiro, F., Lopes, V.M., Pires, V., Lopes, A.R., Pimentel, M.S., Repolho, T., Baptista, M., Narciso, L., Rosa, R., 2013. Physiological and behavioral responses of temperate seahorses (*Hippocampus guttulatus*) to environmental warming. *Marine Biology*. 160, 2663-2670.
- Balcázar, J.L., Gallo-Bueno, A., Planas, M., Pintado, J., 2010. Isolation of *Vibrio alginolyticus* and *Vibrio splendidus* from captive-bred seahorses with disease symptoms. *Antonie van Leeuwenhoek*. 97, 207-210.

- Balcázar, J.L., Planas, M., Pintado, J., 2011. Novel mycobacterium species in seahorses with tail rot. *Emerging infectious diseases*. 17, 1770.
- Balcázar, J.L., Planas, M., Pintado, J., 2012. *Vibrio inhibens* sp. nov., a novel bacterium with inhibitory activity against *Vibrio* species. *The Journal of antibiotics*. 65, 301-305.
- Balon, E.K., 1986. Types of feeding in the ontogeny of fishes and the life-history model. *Environmental Biology of Fishes*. 16, 11-24.
- Bannon, E., Ringler, N.H., 1986. Optimal prey size for stream resident brown trout (*Salmo trutta*): tests of predictive models. *Canadian Journal of Zoology*. 64, 704-713.
- Barroso, M., de Carvalho, C., Antoniassi, R., Cerqueira, V., 2013. Use of the copepod *Acartia tonsa* as the first live food for larvae of the fat snook *Centropomus parallelus*. *Aquaculture*. 388, 153-158.
- Bartley, D., 2000. Responsible Ornamental Fisheries. *FAO Aquaculture Newsletter*. 24, 10.
- Bergert, B.A., Wainwright, P.C., 1997. Morphology and kinematics of prey capture in the syngnathid fishes *Hippocampus erectus* and *Syngnathus floridae*. *Marine Biology*. 127, 563-570.
- Bell, E.M., Lockyear, J.F., McPherson, J.M., Marsden, A.D., Vincent, A.C., 2003. First field studies of an endangered South African seahorse, *Hippocampus capensis*. *Environmental Biology of Fishes*. 67, 35-46.
- Berzins, I.K., Greenwell, M.G., 2005. Syngnathid health management. In: Koldewey, H. (ed.). *Syngnathid Husbandry in Public Aquariums 2005 Manual*, London, pp. 28-38.
- Blake, R.W., 1976. On seahorse locomotion. *Journal of the Marine Biological Association of the United Kingdom*. 56, 939-949.
- Blanco, A., Valladares, S., Calado, R., Planas M., 2010. Effect of the diet in on-growing and maturation of the grass shrimp *Palaemonetes varians* (Leach, 1814). *Aquaculture Europe 2010*, 5–8 Oct 2010, Porto (Portugal).
- Blanco, A., Quintas, P., Planas, M., 2011a. Catabolic sources in the early development of the long-snouted seahorse *Hippocampus guttulatus* under starving conditions. 5th International Husbandry Symposium - The Husbandry, Management and Conservation of Syngnathids, 2–4 Nov 2011, Chicago (USA).

- Blanco, A., Quintas, P., Planas, M., 2011b. Enhancement in the rearing of the seahorse *Hippocampus guttulatus* by feeding on copepods, 5th International Zoo and Aquarium Symposium - The Husbandry, Management and Conservation of Syngnathids, 2–4 Nov 2011, Chicago, Illinois (USA).
- Blanco, A., Quintas, P., Planas, M., 2012. First observations of conjoined twins in newborn seahorses, *Hippocampus guttulatus* Cuvier. *Journal of Fish Diseases*. 35, 705-708.
- Blanco, A., Planas, M., Moyano, F.J., 2013. Digestive enzyme activities of juvenile seahorses *Hippocampus guttulatus* fed on different live prey, Aquaculture Europe 9-12 August 2013, Trondheim, Norway.
- Blanco, A., Chamorro, A., Planas, M., 2014. Implications of physical key factors in the early rearing of the long-snouted seahorse *Hippocampus guttulatus*. *Aquaculture*. Under review.
- Blanco, A., Planas, M., 2014a. Improvements in the rearing of the seahorse *Hippocampus guttulatus* Cuvier 1829 by the use of copepods. *Aquaculture*. Submitted.
- Blanco, A., Planas, M., 2014b. Mouth growth and prey selection in juveniles of the European long-snouted seahorse *Hippocampus guttulatus*. *Aquaculture*. Under review.
- Blasiola, G., 1979. *Glugea heraldi* n. sp.(Microsporida, Glugeidae) from the seahorse *Hippocampus erectus* Perry. *Journal of Fish Diseases*. 2, 493-500.
- Blaxter J.H.S., 1991. The effect of temperature on larval fishes. *Netherlands Journal of Zoology*. 42, 336–357.
- Blaxter, J.H.S., Ehrlich, K.F., 1974. Changes in behaviour during starvation of herring and plaice larvae. In: Blaxter, J.H.S. (ed.). *The early life history of fish*. Springer-Verlag, New York, 575-588 pp.
- Bligh, E.G., Dyer, W.J., 1959. A rapid method of total lipid extraction and purification. *Canadian journal of biochemistry and physiology*. 37, 911-917.
- BOE, 2011. Listado de Especies Silvestres en Régimen de Protección Especial y del Catálogo Español de Especies Amenazadas. Ministerio de Medio Ambiente, Rural y Marino. Available at: https://www.boe.es/diario_boe/txt.php?id=BOE-A-2011-3582. Accessed in March 2014.

- Boisseau, J., 1967. Les regulations hormonales de l'incubation chez un Vertébré male : recherches sur la reproduction de l'Hippocampe. PhD Thesis, Université de Bordeaux, France, 379 pp.
- Bolasina, S., Pérez, A., Yamashita, Y., 2006. Digestive enzymes activity during ontogenetic development and effect of starvation in Japanese flounder, *Paralichthys olivaceus*. *Aquaculture*. 252, 503-515.
- Bradford, M.M., 1976. A rapid and sensitive method for the quantitation of microgram quantities of protein utilizing the principle of protein-dye binding. *Analytical Biochemistry*. 72, 248-254.
- Bray, J.H., Maxwell, S.E., 1985. Multivariate Analysis of Variance. In: Sage University Paper Series on Quantitative Research Methods (ed.). Sage v. 54, Newbury Park, CA (USA).
- Breder, C.M., Edgerton, H.E., 1942. An analysis of the locomotion of the seahorse, *Hippocampus*, by means of high speed cinematography. *Annals of the New York Academy of Sciences*. 43, 145-172.
- Burhans, R., Melechinsky D., 2004. Seahorse Husbandry and Propagation. Available at: http://www.utahreefs.com/articles/AZA_paper_BAS.pdf. Accessed in February 2014.
- Buskey, E.J., Coulter, C., Strom, S., 1993. Locomotory patterns of microzooplankton: potential effects on food selectivity of larval fish. *Bulletin of Marine Science*. 53, 29-43.
- Caballero, A., Rodríguez-Ramilo, S.T., Ávila, V., Fernández, J., 2010. Management of genetic diversity of subdivided populations in conservation programmes. *Conservation Genetics*. 11 (Special Issue), 409-419.
- Cable, L., 1940. A two-headed embryo of the pipefish, *Syngnathus floridae*. *Journal of the Elisha Mitchell Scientific Society*. 56, 135-139.
- Caldwell, I., Vincent, A., 2012. Revisiting two sympatric European seahorse species: apparent decline in the absence of exploitation. *Aquatic Conservation: Marine and Freshwater Ecosystems*. 22, 427-435.
- Caldwell, I.R., 2012. Habitat use, movement, and vulnerability of sedentary fishes in a dynamic world, *Zoology*. University of British Columbia, Vancouver (Canada), pp. 179.

- Caldwell, I.R., Vincent, A.C., 2013. A sedentary fish on the move: effects of displacement on long-snouted seahorse (*Hippocampus guttulatus* Cuvier) movement and habitat use. *Environmental Biology of Fishes*. 96, 67-75.
- Camacho Rosales, J., 1995. Análisis multivariado con SPSS/PC+. Ediciones Universitarias de Barcelona. Barcelona (Spain). 351pp.
- Campagnolo, R., Nuñez, A.P.O., 2008. Survival and growth of *Pseudoplatystoma corruscans* (Pisces - Pimelodidae) larvae: effect of photoperiod. *Arquivo Brasileiro de Medicina Veterinária e Zootecnia*. 60, 1511-1516.
- Carcupino, M., Baldacci, A., Mazzini, M., Franzoi, P., 2002. Functional significance of the male brood pouch in the reproductive strategies of pipefishes and seahorses: a morphological and ultrastructural comparative study on three anatomically different pouches. *Journal of Fish Biology*. 61, 1465-1480.
- Castro, A.L.d.C., Diniz, A.d.F., Martins, I.Z., Vendel, A.L., Oliveira, T.P.R.d., Rosa, I.M.d.L., 2008. Assessing diet composition of seahorses in the wild using a non destructive method: *Hippocampus reidi* (Teleostei: Syngnathidae) as a study-case. *Neotropical Ichthyology*. 6, 637-644.
- Celino, F.T., Hilomen-Garcia, G.V., del Norte-Campos, A.G.C., 2012. Feeding selectivity of the seahorse, *Hippocampus kuda* (Bleeker), juveniles under laboratory conditions. *Aquaculture Research*. 43, 1804-1815.
- Chambers, R.C., Leggett, W., 1992. Possible causes and consequences of variation in age and size at metamorphosis in flatfishes (Pleuronectiformes): an analysis at the individual, population and species level. *Netherlands Journal of Sea Research*. 29, 7-24.
- Chamorro, A., Hermelo, T., Planas, M., 2010. A methodology for the reproduction and early on-growing of the grass shrimp *Palaemonetes varians*. *European Aquaculture Society, Aquaculture Europe 10*, 5-8 October 2010Porto (Portugal).
- Chang, M., Southgate, P.C., 2001. Effects of varying dietary fatty acid composition on growth and survival of seahorse, *Hippocampus* sp., juveniles. *Aquarium Sciences and Conservation*. 3, 205-214.

- Chen, J., 1990. Brief introduction to mariculture of five selected species in China. In: UNDP/FAO Regional Seafarming Development and Demonstration Project. National Inland Fisheries Institute Kasetsart (ed.). University Campis, Bangkok, Thailand. 16.
- Chitty, N., 1981. Behavioral observations of feeding larvae of bay anchovy, *Anchoa mitchilli*, and bigeye anchovy, *Anchoa lamprotaenia*. Rapports et Proces-verbaux des Réunions. Conseil International pour l'Éxploration de la Mer. 178, 320-321
- Choo, C., Liew, H., 2006. Morphological development and allometric growth patterns in the juvenile seahorse *Hippocampus kuda* Bleeker. Journal of Fish Biology. 69, 426-445.
- CITES, 2002. Convention on international trade in endangered species of wild fauna and flora, Twelfth Meeting of the Convergence of the Parties, Santiago de Chile, Chile.
- Confer, J.L., Lake, G.J., 1987. Influence of Prey Type on Growth of Young Yellow Perch (*Perca flavescens*). Canadian Journal of Fisheries and Aquatic Sciences. 44, 2028-2033.
- Correa, M., Chung, K.S., Manrique, R., 1989. Experimental culture of the seahorse, *Hippocampus erectus*. Boletín del Instituto Oceanográfico de Venezuela. 28, 91-196.
- Correia, M., Palma, J., Koldewey, H., Andrade, J.P., 2013. Can artificial holdfast units work as a habitat restoration tool for long-snouted seahorse (*Hippocampus guttulatus* Cuvier)? Journal of Experimental Marine Biology and Ecology. 448, 258-264.
- Cox, E.S., Pankhurst, P.M., 2000. Feeding behaviour of greenback flounder larvae, *Rhombosolea tapirina* (Günther) with differing exposure histories to live prey. Aquaculture. 183, 285-297.
- Cripps, S.J., Poxton, M.G., 1992. A review of the design and performance of tanks relevant to flatfish culture. Aquacultural Engineering. 11, 71-91.
- Cunha, I., Planas, M., 1995. Ingestion rates of turbot larvae (*Scophthalmus maximus* L.) using different-sized live prey, ICES Marine Science Symposia. Copenhagen, Denmark: International Council for the Exploration of the Sea, 1991, pp. 16-20.
- Cunha, I., Planas, M., 1997. Temperature does not affect the fatty acid utilization in unfed turbot (*Scophthalmus maximus* L.) larvae. Third International Symposium on Research for Aquaculture: Research and Applied Aspects, 24–27 August 1997. Barcelona.
- Cunha, I., Planas, M., 1999. Optimal prey size for early turbot larvae (*Scophthalmus maximus* L.) based on mouth and ingested prey size. Aquaculture. 175, 103-110.

- Cunha, I., Saborido-Rey, F., Planas, M., 2003. Use of multivariate analysis to assess the nutritional condition of fish larvae from nucleic acids and protein content. *Biological Bulletin*. 204, 339-349.
- Cunha, I., Conceição, L.E.C., Planas, M., 2007. Energy allocation and metabolic scope on early turbot, *Scophthlamus maximus*, larvae. *Marine Biology*. 151, 1397-1405.
- Curtis, J.M.R., 2004. Life history, ecology and conservation of European seahorses, *Biology*. PhD Thesis, McGill University, Montréal, Quebec, 235 pp.
- Curtis, J.M.R., 2006a. A case of mistaken identity: skin filaments are unreliable for identifying *Hippocampus guttulatus* and *Hippocampus hippocampus*. *Journal of Fish Biology*. 69, 1855-1859.
- Curtis, J.M.R., 2006b. Visible implant elastomer color determination, tag visibility, and tag loss: potential sources of error for mark–recapture studies. *North American Journal of Fisheries Management*. 26, 327-337.
- Curtis, J.M.R., 2007. Validation of a method for estimating realized annual fecundity in a multiple spawner, the long-snouted seahorse (*Hippocampus guttulatus*), using underwater visual census. *Fishery Bulletin*. 105, 327-336.
- Curtis, J.M.R., Vincent, A. C. J., 2005. Distribution of sympatric seahorse species along a gradient of habitat complexity in a seagrass-dominated community. *Marine Ecology Progress Series*. 291, 81–91.
- Curtis, J.M.R, Vincent, A.C.J., 2006. Life history of an unusual marine fish: survival, growth and movement patterns of *Hippocampus guttulatus* Cuvier 1829. *Journal of Fish Biology*. 68, 707-733.
- DEFRA, 2008. UK wildlife and countryside Act of 2008. Available at: <http://www.legislation.gov.uk/uksi/2008/>. Accessed in March 2014
- Di Cicco, E., Paradis, E., Stephen, C., Turba, M.E., Rossi, G., 2013. Scuticociliatid ciliata outbreak in Australian pot-bellied seahorse, *Hippocampus abdominalis* (Lesson, 1827): Clinical signs, histopathologic findings, and treatment with metronidazole. *Journal of Zoo and Wildlife Medicine*. 44, 435-440.

- Dou, S.Z., Masuda, R., Tanaka, M., Tuskamoto, K., 2005. Effects of temperature and delayed initial feeding on the survival and growth of Japanese flounder larvae. *Journal of Fish Biology*. *Fish Biol.* 66, 362-377.
- Drillet, G., Jepsen, P.M., Højgaard, J.K., Jørgensen, N.O., Hansen, B.W., 2008. Strain-specific vital rates in four *Acartia tonsa* cultures II: Life history traits and biochemical contents of eggs and adults. *Aquaculture*. 279, 47-54.
- Drillet, G., Jørgensen, N.O., Sørensen, T.F., Ramløv, H., Hansen, B.W., 2006. Biochemical and technical observations supporting the use of copepods as live feed organisms in marine larviculture. *Aquaculture Research*. 37, 756-772.
- Duarte, S., Reig, L., Masaló, I., Blanco, M., Oca, J., 2011. Influence of tank geometry and flow pattern in fish distribution. *Aquacultural Engineering*. 44, 48-54.
- Dubois, M., Gilles, K.A., Hamilton, J.K., Rebers, P.t., Smith, F., 1956. Colorimetric method for determination of sugars and related substances. *Analytical chemistry*. 28, 350-356.
- Dulvy, N.K., Sadovy, Y., Reynolds, J.D., 2003. Extinction vulnerability in marine populations. *Fish and Fisheries*. 4, 25-64.
- Ehrlich, K.F., 1974. Chemical changes during growth and starvation of larval *Pleuronectes platessa*. *Marine Biology*. 24, 39-48
- Eshagh-Zadeh, H., Rafiee, G., Eagderi, S., Kazemi, R., Poorbagher, H., 2013. Effects of different photoperiods on the survival and growth of beluga sturgeon (*Huso huso*) larvae. *International Journal of Aquatic Biology*. 1, 36-41.
- Falcão, M., Vale, C., 2003. Nutrient dynamics in a coastal lagoon (Ria Formosa, Portugal): The importance of lagoon–sea water exchanges on the biological productivity. *Ciencias Marinas*. 29, 425–433.
- Faleiro, F., 2011. A new home for the long-snouted seahorse, *Hippocampus guttulatus*: Breeding in captivity to preserve in the wild. PhD Thesis, Universidade de Lisboa, Lisbon, Portugal, 118 pp.
- Faleiro, F, Narciso, L, Vicente L., 2008. Seahorse behaviour and aquaculture: How to improve *Hippocampus guttulatus* husbandry and reproduction? *Aquaculture*. 282, 33-40.

- Faleiro, F., Narciso, L., 2010. Lipid dynamics during early development of *Hippocampus guttulatus* seahorses: Searching for clues on fatty acid requirements. *Aquaculture*. 307, 56-64.
- Faleiro, F., Narciso, L., 2013. Prey–predator dynamics in seahorses (*Hippocampus guttulatus*): deciphering fatty acid clues. *Aquaculture Research*. 44, 618-633.
- FAO, 2014. Fisheries and Aquaculture topics. Ornamental fish. Topic fact sheets. In: Bartley, D. (Ed.), FAO Fisheries and Aquaculture Department, Rome.
- Faulk, C.K., Benninghoff, A.D., Holt, G.J., 2007. Ontogeny of the gastrointestinal tract and selected digestive enzymes in cobia *Rachycentron canadum* (L.). *Journal of Fish Biology*. 70, 567-583.
- Felício, A., Rosa, I., Souto, A., Freitas, R.A., 2006. Feeding behavior of the longsnout seahorse *Hippocampus reidi* Ginsburg, 1933. *Journal of Ethology*. 24, 219-225.
- Fernández-Reiriz, M.J., Perez-Camacho, A., Ferreiro, M., Blanco, J., Planas, M., Campos, M.J., Labarta, U., 1989. Biomass production and variation in the biochemical profile (total protein, carbohydrates, RNA, lipids and fatty acids) of seven species of marine microalgae. *Aquaculture*. 83, 17-37.
- Ferron, A., Leggett, W.C., 1994. An appraisal of condition measures for marine fish larvae. In: Blaxter, J.H.S. & Southward, A.J. (eds). *Advances in Marine Biology*. 30, 217-303. Québec: Academic Press.
- Fiedler, K., 1970. Hormonal control of parturition in the seahorse (*Hippocampus*, Syngnathidae, Teleostei). *Zeitschrift fur Tierpsychologie*. 27, 679-686.
- Fielder, D.S., Bardsley, W.J., Allan, G.L., Pankhurst, P.M., 2002. Effect of photoperiod on growth and survival of snapper *Pagrus auratus* larvae. *Aquaculture*. 211, 135-150.
- Figueiredo, J., van Woesik, R., Lin, J., Narciso, L., 2009. *Artemia franciscana* enrichment model — How to keep them small, rich and alive? *Aquaculture*. 294, 212-220.
- Fish, M.P., 1953. The production of underwater sound by the northern seahorse, *Hippocampus hudsonius*. *Copeia*, 98-99.
- Fishbase, 2014. Hippocampus. Available at: <http://www.fishbase.org>. Accessed: March 2014.

- Foster, S.J., Vincent, A.C.J., 2004. Life history and ecology of seahorses: implications for conservation and management. *Journal of Fish Biology*. 65, 1-61.
- Fritsches, K.A., Marshall, N.J., 2002. Independent and conjugate eye movements during optokinesis in teleost fish. *Journal of Experimental Biology*. 205, 1241-1252.
- Fui, C.F., Miura, A., Nakagawa, Y., Kato, K., Senoo, S., Sakamoto, W., Takii, K., Miyashita, S., 2012. Flow field control via aeration adjustment for the enhancement of larval survival of the kelp grouper *Epinephelus bruneus* (Perciformes:Serranidae). *Aquaculture Research*. 1-8.
- Fuiman, L.A., Poling, K.R., Higgs, D.M., 1998. Quantifying developmental progress for comparative studies of larval fishes. *Copeia*. 1998, 602-611.
- Fukuhara, O., 1987. Larval development and behaviour in early life stages of black sea bream reared in the laboratory. *Bulletin of the Japanese Society of Scientific Fisheries*. 53, 371-379.
- Fukuhara, O., 1990. Effects of temperature on yolk utilization, initial growth, and behaviour of unfed marine fish-larvae. *Marine Biology*. 106, 169-174.
- Furné, M., García-Gallego, M., Hidalgo, M.C., Morales, A.E., Domezain, A., Domezain, J., Sanz, A., 2008. Effect of starvation and refeeding on digestive enzyme activities in sturgeon (*Acipenser naccarii*) and trout (*Oncorhynchus mykiss*). *Comparative Biochemistry and Physiology: Part A*. 149, 420-425.
- Gago J, Cabanas J.M., Casas, G., Miranda, A., 2011. Thermohaline measurements in the continental shelf zone of the NW Iberian Peninsula, 1994–2006. *Climate Research*. 48, 219-229.
- Galloway, T.F., Kjørsvik, E., Kryvi, H., 1998. Effect of temperature on viability and axial muscle development in embryos and yolk sac larvae of the Northeast Arctic cod (*Gadus morhua*). *Marine Biology*. 132, 559-567.
- García, L.M.B., Hilomen-Garcia, G.V., 2009. Growth-out of juvenile seahorse *Hippocampus kuda* (Bleeker: Teleostei: Syngnathidae) in illuminated sea cages. *Aquaculture Research*. 40, 211-216.

- García, L.M.B., Hilomen-Garcia, G.V., Calibara, R.L.M., 2010. Culturing seahorse (*Hippocampus barbouri*) in illuminated cages with supplementary *Acetes* feeding. Israeli Journal of Aquaculture - Bamidegh. 62, 122-129.
- Gardner, T., 2008. The copepod/*Artemia* tradeoff in the captive culture of *Hippocampus erectus*, a vulnerable species in lower New York State, Marine Ornamental Species. Blackwell Publishing Company, 297-304.
- Garrick-Maidment, N., 1998. A note on the status of indigenous species of seahorse. Journal of the Marine Biological Association of the United Kingdom. 78, 691-692.
- Garrick-Maidment, N., 2004. British Seahorse Survey Report. In: survey, B.s. (Ed.). Available at: <http://www.theseahorsetrust.org/>, Topsham, Devon, pp. 82.
- Garrick-Maidment, N., 2007. British Seahorse Survey 2007. In: WWF, T.E.o.B.V.P.a. (Ed.). Available at: <http://www.theseahorsetrust.org/>, Topsham, Devon. pp. 26.
- Garrick-Maidment, N., 2011. British Seahorse Survey Report 2011. In: Trust, T.S. (Ed.). Available at: <http://www.theseahorsetrust.org/>, Topsham, Devon. pp. 50.
- Garrick-Maidment, N., Newman, J., Durant, E., 2010. Movement of a pair of spiny seahorses (*Hippocampus guttulatus*) seen during the summer of 2010 at Studland Bay in Dorset. <http://www.theseahorsetrust.org/>, Dorset.
- Gill, T., 1905. The life history of the sea-horses (Hippocampids). Proceedings of the United States National Museum. 28, 805-514.
- Gisbert, E., Piedrahita, R.H., Conklin, D.E., 2004. Ontogenetic development of the digestive system in California halibut (*Paralichthys californicus*) with notes on feeding practices. Aquaculture 232, 455-470.
- Gomezjurado, J., 2005. Pacific seahorse, *Hippocampus ingens*. in: Koldewey, H. (Ed.), Syngnathid Husbandry in Public Aquariums 2005. London, UK. pp. 72-74.
- Gomezjurado, J., Gardner, T., 2005. Slender seahorse, *Hippocampus reidi*. in: Koldewey, H. (Ed.), Syngnathid Husbandry Manual in Public Aquariums 2005. London, UK. pp. 80-84.
- Govoni, J., Boehlert, G., Watanabe, Y., 1986. The physiology of digestion in fish larvae. Environmental Biology of Fishes. 16, 59-77.

- Gutowska, M.A., Drazen, J.C., Robison, B.H., 2004. Digestive chitinolytic activity in marine fishes of Monterey Bay, California. *Comparative Biochemistry and Physiology: Part A*. 139, 351-358.
- Hambright, K.D., 1991. Experimental analysis of prey selection by largemouth bass: Role of predator mouth width and prey body depth. *Transactions of the American Fisheries Society*. 120, 500-508.
- Harboe, T., Mangor-Jensen, A., Naas, K., Næss, T., 1998. A tank design for first feeding of Atlantic halibut, *Hippoglossus hippoglossus* L., larvae. *Aquaculture Research*. 29, 919-923.
- Herald, E.S., 1959. From pipefish to seahorse: a study of phylogenetic relationships. *The Academy*.
- Herald, E.S., Rakowicz, M., 1951. Stable requirements for raising seahorses. *The Aquarium Journal*. 22, 234-242.
- Holmes, E. J., Holmes, J.M.C., 1991. Fish note: seahorse *Hippocampus ramulosus* Leach in Lough Hyne, Co Cork. *Irish Naturalists' Journal*. 23, 426-427.
- Hora, M.d.S.C.d., Joyeux, J.C., 2009. Closing the reproductive cycle: Growth of the seahorse *Hippocampus reidi* (Teleostei, Syngnathidae) from birth to adulthood under experimental conditions. *Aquaculture*. 292, 37-41.
- Houde, E.D., 1989. Comparative growth, mortality, and energetics of marine fish larvae: Temperature and implied latitudinal effects. *Fisheries Bulletin*. 87, 471-495.
- Huisman, E.A., 1974. Optimalisering van de groei bij de karper, *Cyprinus carpio*. PhD Thesis, Wageningen Agricultural University, The Netherlands, 95 pp. (in Dutch).
- Hunter, J.R., 1981. Feeding ecology and predation of marine larvae in Marine fish larvae. In: Lasker, R. (Ed.), *Marine fish larvae: morphology, ecology, and relation to fisheries*. University of Washington, Seattle, pp. 34-77.
- IAA, 1981. Yizre'el Valley Silver hoard. In: Israel Antiquities Authority, (Ed.), Available at: http://www.antiquities.org.il/hoards_eng.asp.
- Ikeda, M., Miyauchi, K., Mochizuki, A. & Matsumiya, M. (2009). Purification and characterization of chitinase from the stomach of silver croaker *Pennahia argentatus*. *Protein Expression and Purification*. 65, 214-222.

- ITIS, 2013. Integration Taxonomic Information System. Available at: <http://www.itis.gov>. Accessed in March 2014.
- IUCN, 2006. The IUCN Red list of Threatened Species. Version 2006.1. In: <http://www.iucnredlist.org>. Accessed in August 2012.
- IUCN, 2013. The IUCN Red List of Threatened Species. Version 2013.1. In: <http://www.iucnredlist.org>. Accessed in June 2013.
- IUCN, 2014. The IUCN Red List of Threatened Species. Version 2014.1. In: <http://www.iucnredlist.org>. Accessed in March 2014.
- Ivlev, V.S., 1961. Experimental ecology of the feeding of fishes. Yale University Press, New Haven, Conn
- Izquierdo, M.S., Socorro, J., Arantzamendi, L., Hernández-Cruz, C.M., 2000. Recent advances in lipid nutrition in fish larvae. *Fish Physiology and Biochemistry*. 22, 97-107
- James, P.L., Heck Jr, K.L., 1994. The effects of habitat complexity and light intensity on ambush predation within a simulated seagrass habitat. *Journal of Experimental Marine Biology and Ecology*. 176, 187-200.
- James, P. Woods, C.M.C., 2001. Rearing seahorses: does temperature matter? *Aquaculture Update* 28, 9-10.
- JNCC, 2010. UK priority species data collation. In: Committee, J.N.C. (Ed.). Available at: <http://jncc.defra.gov.uk/speciespages/2336.pdf>.
- Job, S.D., Do, H.H., Meeuwig, J.J., Hall, H.J., 2002. Culturing the oceanic seahorse, *Hippocampus kuda*. *Aquaculture*. 214, 333-341.
- Job, S., Buu, D., Vincent, A., 2006. Growth and survival of the tiger tail seahorse, *Hippocampus comes*. *Journal of the World Aquaculture Society*. 37, 322-327.
- Jobling M., 1997. Temperature and growth: modulation of growth rate via temperature change. In: Wood C. M. and McDonald D. G., (ed). *Global Warming: Implications for Freshwater and Marine Fish*. Cambridge University Press, 223-254 pp.
- Johnson, A.F., Valls, M., Moranta, J., Jenkins, S.R., Hiddink, J.G., Hinz, H., 2012. Effect of prey abundance and size on the distribution of demersal fishes. *Canadian Journal of Fisheries and Aquatic Sciences*. 69, 191-200.

- Jones, A.G., Kvarnemo, C., Moore, G.I., Simmons, L.W., Avise, J.C., 1998. Microsatellite evidence for monogamy and sex-biased recombination in the Western Australian seahorse *Hippocampus angustus*. *Molecular ecology*. 7, 1497-1505.
- Kamarudin, M.S., Otoi, S., Saad, C.R., 2011. Changes in growth, survival and digestive enzyme activities of Asian redbtail catfish, *Mystus nemurus*, larvae fed on different diets. *African Journal of Biotechnology*. 10, 4484-4493
- Kamler, E., 1992. Early life history of fish: An energetics approach. In: Chapman & Hall (ed.). Springer, London, 267 pp.
- Kamler, E., 2002. Ontogeny of yolk-feeding fish: an ecological perspective. *Reviews in Fish Biology and Fisheries*. 12, 79–103.
- Kamler, E., Szlaminska, M., Kuckzynski, M., Hamackova, J., Kouril, J. Dabrowski, R., 1994. Temperature-induced changes of early development and yolk utilization in the African catfish *Clarias gariepinus*. *Journal of Fish Biology*. 44, 311-326.
- Kane, E.A., Higham, T.E., 2011. The integration of locomotion and prey capture in divergent cottid fishes: functional disparity despite morphological similarity. *The Journal of Experimental Biology*. 214, 1092-1099.
- Kanou, K., Kohno, H., 2001. Early life history of a seahorse, *Hippocampus mohnikei*, in Tokyo Bay, Japan. *Ichthyological Research*. 48, 361-368.
- Kendrick, A.J., Hyndes, G.A., 2005. Variations in the dietary compositions of morphologically diverse syngnathid fishes. *Environmental Biology of Fishes*. 72, 415-427.
- Keskin, Ç., 2010. A review of fish fauna in the Turkish Black Sea Karadeniz balık faunası. *Journal of Black Sea and Mediterranean Environment*. 16, 195-210.
- Kim, B.G., Brown, C.L., 1994. Hormonal manipulation of digestive enzyme ontogeny in marine larval fishes-effects on digestive enzymes. *UNJR Technical Reports*. 28, 47-58
- Kim, B.G., Divakaran, S., Brown, C.L., Ostrowski, A., 2001. Comparative digestive enzyme ontogeny in two marine larval fishes, Pacific threadfin (*Polydactylus sexfilis*) and bluefin trevally (*Caranx melampygus*). *Fish Physiology and Biochemistry*. 24, 225-241.
- Kitsos, M.S., Tzomos, T., Anagnostopoulou, L., Koukouras, A., 2008. Diet composition of the seahorses, *Hippocampus guttulatus* Cuvier, 1829 and *Hippocampus hippocampus* (L.,

- 1758) (Teleostei, Syngnathidae) in the Aegean Sea. *Journal of Fish Biology*. 72, 1259-1267.
- Kleiber, D., Blight, L., Caldwell, I., Vincent, A., 2011. The importance of seahorses and pipefishes in the diet of marine animals. *Reviews in Fish Biology and Fisheries*. 21, 205-223.
- Koldewey, H., 2005. *Syngnathid Husbandry in Public Aquariums: 2005 Manual*, with chapters contributed by members of the Syngnathidae Discussion Group. Project Seahorse and Zoological Society of London, London, UK.
- Koldewey, H.J., Martin-Smith, K.M., 2010. A global review of seahorse aquaculture. *Aquaculture*. 302, 131-152.
- Lauff, M., Hofer, R., 1984. Proteolytic enzymes in fish development and the importance of dietary enzymes. *Aquaculture*. 37, 335-346.
- Laurel, B.J., Hurst, T.P., Copeman, L.A. Davis, M.W., 2008. The role of temperature on the growth and survival of early and late hatching Pacific cod larvae (*Gadus macrocephalus*). *Journal of Plankton Research*. 30, 1051-1060.
- Lavens, P., Sorgeloos, P., 1996. *Manual on the production and use of live food for aquaculture*. Food and Agriculture Organization (FAO).
- Lazo, J.P., Mendoza, R., Holt, G.J., Aguilera, C., Arnold, C.R., 2007. Characterization of digestive enzymes during larval development of red drum (*Sciaenops ocellatus*). *Aquaculture*. 265, 194-205.
- Lemieux, H., Blier, P., Dutil, J.D., 1999. Do digestive enzymes set a physiological limit on growth rate and food conversion efficiency in the Atlantic cod (*Gadus morhua*)? *Fish Physiology and Biochemistry*. 20, 293-303.
- Lee, H.R., Bumsted O'Brien, K.M., 2011. Morphological and behavioral limit of visual resolution in temperate (*Hippocampus abdominalis*) and tropical (*Hippocampus taeniopterus*) seahorses. *Visual neuroscience*. 28, 351-360.
- LePage, V., Dutton, C.J., Kummrow, M., McLelland, D.J., Young, K., Lumsden, J.S., 2012. Neoplasia of captive yellow sea horses (*Hippocampus kuda*) and weedy sea dragons (*Phyllopteryx taeniolatus*). *Journal of Zoo and Wildlife Medicine*. 43, 50-58.

- Lewis, E., Kucera, M., Tappert, R., Tessadri, R., Tappert, M., Kanz, F., 2013. Occurrence of nephrolithiasis in a population of longsnout seahorse, *Hippocampus reidi* Ginsburg, and analysis of a nephrolith. *Journal of Fish Diseases*. 36, 163-167.
- Leysen, H., Roos, G., Adriaens, D., 2011. Morphological variation in head shape of pipefishes and seahorses in relation to snout length and developmental growth. *Journal of Morphology*. 272, 1259-1270.
- Leysen, H., Christiaens, J., De Kegel, B., Boone, M.N., Van Hoorebeke, L., Adriaens, D., 2011a. Musculoskeletal structure of the feeding system and implications of snout elongation in *Hippocampus reidi* and *Dunckerocampus dactyliophorus*. *Journal of Fish Biology*. 78, 1799-1823.
- Leysen, H., Dumont, E.R., Brabant, L., Van Hoorebeke, L.U.C., Adriaens, D., 2011b. Modelling stress in the feeding apparatus of seahorses and pipefishes (Teleostei: Syngnathidae). *Biological Journal of the Linnean Society*. 104, 680-691.
- Leysen, H., Jouk, P., Brunain, M., Christiaens, J., Adriaens, D., 2010. Cranial architecture of tube-snouted gasterosteiformes (*Syngnathus rostellatus* and *Hippocampus capensis*). *Journal of Morphology*. 271, 255-270.
- Leysen, H., Roos, G., Adriaens, D., 2011c. Morphological variation in head shape of pipefishes and seahorses in relation to snout length and developmental growth. *Journal of Morphology*. 272, 1259-1270.
- Lin, Q., Gao, Y., Sheng, J., Chen, Q., Zhang, B., Lu, J., 2007. The effects of food and the sum of effective temperature on the embryonic development of the seahorse, *Hippocampus kuda* Bleeker. *Aquaculture*. 262, 481-492.
- Lin, Q., Lin, J., Huang, L., 2010. Effects of light intensity, stocking density and temperature on the air-bubble disease, survivorship and growth of early juvenile seahorse *Hippocampus erectus* Perry, 1810. *Aquaculture Research*. 42, 91-98.
- Lin, Q., Lin, J., Lu, J., Li, B., 2008. Biochemical composition of six seahorse species, *Hippocampus* sp., from the Chinese coast. *Journal of the World Aquaculture Society*. 39, 225-234.

- Lin, Q., Lin, J., Wang, C., 2009. Biochemical composition of the wild and cultured seahorses, *Hippocampus kuda* Bleeker and *Hippocampus trimaculatus* Leach. *Aquaculture Research*. 40, 710-719.
- Lin, Q., Lu, J., Gao, Y., Shen, L., Cai, J., Luo, J., 2006. The effect of temperature on gonad, embryonic development and survival rate of juvenile seahorses, *Hippocampus kuda* Bleeker. *Aquaculture*. 254, 701-713.
- Lindley, L.C., Phelps, R.P., Davis, D.A., Cummins, K.A., 2011. Salinity acclimation and free amino acid enrichment of copepod nauplii for first-feeding of larval marine fish. *Aquaculture*. 318, 402-406.
- Linton, J., Soloff, B., 1964. The physiology of the brood pouch of the male sea horse *Hippocampus erectus*. *Bulletin of Marine Science*. 14, 45-61.
- Lockyear, J., Kaiser, H., Hecht, T., 1997. Studies on the captive breeding of the Knysna seahorse, *Hippocampus capensis*. *Aquarium Sciences and Conservation*. 1, 129-136.
- López, A., 2011. Aplicación de marcadores moleculares al análisis de recursos genéticos y desarrollo del cultivo en especies de caballito de mar del Atlántico noreste, Genetic Department. PhD Thesis, University of Santiago de Compostela, Santiago de Compostela, Spain, 322 pp.
- López, A., Vera, M., Otero-Ferrer, F., Pardo, B., Martínez, P., Molina, L., Bouza, C., 2010. Species identification and genetic structure of threatened seahorses in Gran Canaria Island (Spain) using mitochondrial and microsatellite markers. *Conservation Genetics*. 11, 2431-2436.
- López, A., Pardo, B.G., Planas, M., Quintas, P., Martínez, P., Bouza, C., 2012. A microsatellite panel for mating system analysis and broodstock management of captive long-snouted seahorse *Hippocampus guttulatus*. *Aquaculture*. 356-357, 153-157.
- Lourie, S., 2003. Measuring seahorses. Project Seahorse Technical Report No.4, Version 1.0. Project Seahorse, Fisheries Centre, University of British Columbia. 15 pp.
- Lourie, S.A., Pritchard, J.C., Casey, S.P., Truong, S.K., Hall, H.J., Vincent, A.C.J., 1999. The taxonomy of Vietnam's exploited seahorses (family Syngnathidae). *Biological Journal of the Linnean Society*. 66, 231-256.

- Lourie, S.A., Vincent, A.C., 2004. Using biogeography to help set priorities in marine conservation. *Conservation Biology*. 18, 1004-1020.
- Lowry, O.H., Rosebrough, N.J., Farr, A.L., Randall, R.J., 1951. Protein measurement with the Folin phenol reagent. *Journal of biological chemistry*. 193, 265-275.
- Luizi, F.S., Gara, B., Shields, R.J., Bromage, N.R., 1999. Further description of the development of the digestive organs in Atlantic halibut (*Hippoglossus hippoglossus*) larvae, with notes on differential absorption of copepod and *Artemia* prey. *Aquaculture*. 176, 101-116.
- Lythgoe, J., Lythgoe, G., 1971. Family Syngnathidae. *Fishes of the Sea*. In: Blandford Press (ed.), London, UK, pp. 182-187.
- Martínez, A., Gardner, T., Littlehale, D., 2005. Lined seahorse, *Hippocampus erectus*. in: Koldewey, H. (Ed.), *Syngnathid Husbandry in Public Aquariums 2005 Manual*. London, pp. 54-61.
- Marichamy, R., Lipton, A., Ganapathy, A., Ramalingam, J., 1993. Large scale exploitation of sea horse (*Hippocampus kuda*) along the Palk Bay coast of Tamil Nadu. *Marine Fisheries Information Service, Technical and Extension Series*. 119, 17-20.
- Martin-Smith, K.M., Vincent, A.C., 2006. Exploitation and trade of Australian seahorses, pipehorses, sea dragons and pipefishes (Family Syngnathidae). *Oryx*. 40, 141-151.
- Martínez-Cárdenas, L., Purser, G.J., 2007. Effect of tank colour on *Artemia* ingestion, growth and survival in cultured early juvenile pot-bellied seahorses (*Hippocampus abdominalis*). *Aquaculture*. 264, 92-100.
- Martínez-Cárdenas, L., Purser, G.J., 2012. Effect of stocking density and photoperiod on growth and survival in cultured early juvenile pot-bellied seahorses *Hippocampus abdominalis* Lesson, 1827. *Aquaculture Research*. 43, 1536-1549.
- Martins, M., Mouriño, J., Fezer, G., Buglione Neto, C., Garcia, P., Silva, B., Jatobá, A., Vieira, F., 2010. Isolation and experimental infection with *Vibrio alginolyticus* in the seahorse, *Hippocampus reidi* Ginsburg, 1933 (Osteichthyes: Syngnathidae) in Brazil. *Brazilian Journal of Biology*. 70, 205-209.
- Masonjones, H.D., Lewis, S.M., 1996. Courtship behavior in the dwarf seahorse, *Hippocampus zosterae*. *Copeia*, 634-640.

- Matlock, G., 1992. Life-history aspects of seahorses, *Hippocampus*, in Texas. Texas Journal of Science. 44, 213-222.
- Meyer, A., 1986. Changes in behavior with increasing experience with a novel prey in fry of the Central American cichlid, *Cichlasoma managuense* (Teleostei: Cichlidae). Behaviour. 98, 145-167.
- Molina, L., Socorro, J., Herrera, R., Otero, F., Villares, P., Fernández-Palacios, H., Izquierdo, M., 2007. Experiencias preliminares de cultivo de crías de *Hippocampus hippocampus* (Linnaeus, 1758) en Gran Canaria, XI Congreso Nacional de Acuicultura, 24-28 September 2007, Vigo (Spain).
- Molinari, L.M., Pedroso, R.B., Scoaris, D.O., Ueda-Nakamura, T., Nakamura, C.V., Dias Filho, B.P., 2007. Identification and partial characterisation of a chitinase from Nile tilapia, *Oreochromis niloticus*. Comparative Biochemistry and Physiology: Part B. 146, 81-87.
- Moore, A., Prange, M.A., Summerfelt, R.C., Bushman, R.P., 1994. Evaluation of tank shape and a surface spray for intensive culture of larval walleyes fed formulated feed. The progressive fish-culturist. 56, 100-110.
- Mortensen, A., Wallin, H., Appelqvist, L., Everitt, G., Gref, C., Jacobsen, J., Jensen, K., Jepsen, O., Johansen, I., Julshamn, K., 1988. Gravimetric determination of ash in foods: NMKL collaborative study. Journal-Association of Official Analytical Chemists. 72, 481-483.
- Mosk, V., Thomas, N., Hart, N.S., Partridge, J.C., Beazley, L.D., Shand, J., 2007. Spectral sensitivities of the seahorses *Hippocampus subelongatus* and *Hippocampus barbouri* and the pipefish *Stigmatopora argus*. Visual neuroscience. 24, 345-354.
- Munilla-Morán, R., Stark, J.R., 1989. Protein digestion in early turbot larvae, *Scophthalmus maximus* (L.). Aquaculture. 81, 315-327.
- Munilla-Morán, R., Stark, J.R., Barbour, A., 1990. The role of exogenous enzymes on the digestion of cultured turbot larvae (*Scophthalmus maximus* L.). Aquaculture. 88, 335-350.
- Munilla-Morán, R., Ferreiro, M.J., Fernández-Reiríz, M.J., Labarta, U., Planas, M., 1993. Effect of environmental factors on lipid digestion during early turbot (*Scophthalmus*

- maximus*) larvae development. In: Walther, B.T. & Fyhn, H.J., (ed.). Physiology and biochemistry of fish larval development. University of Bergen, Norway: Academic Press, 167-171 pp.
- Munilla-Morán, R., Saborido-Rey, F., 1996. Digestive enzymes in marine species. II. Amylase activities in gut from seabream (*Sparus aurata*), turbot (*Scophthalmus maximus*) and redfish (*Sebastes mentella*). Comparative Biochemistry and Physiology: Part B. 113, 827-834.
- Murugan, A., Dhanya, S., Sreepada, R., Rajagopal, S., Balasubramanian, T., 2009. Breeding and mass-scale rearing of three spotted seahorse, *Hippocampus trimaculatus* Leach under captive conditions. Aquaculture. 290, 87-96.
- Naas, K., Huse, I., Iglesias, J., 1996. Illumination in first feeding tanks for marine fish larvae. Aquacultural Engineering. 15, 291-300.
- Nash, C.E., Kuo, C.M., Madden, W.D., Paulsen, C.L., 1977. Swim bladder inflation and survival of *Mugil cephalus* to 50 days. Aquaculture. 12, 89-94.
- Naud, M.-J., Curtis, J.M., Woodall, L.C., Gaspar, M.B., 2009. Mate choice, operational sex ratio, and social promiscuity in a wild population of the long-snouted seahorse *Hippocampus guttulatus*. Behavioral Ecology. 20, 160-164.
- Neilson, J., Perry, R., Valerio, P., Waiwood, K., 1986. Condition of Atlantic cod *Gadus morhua* larvae after the transition to exogenous feeding morphometrics, buoyancy and predator avoidance. Marine Ecology Progress Series. 32, 229-235.
- O'Connell, C.P., 1976. Histological criteria for diagnosing the starving condition in early post yolk sac larvae of the northern anchovy, *Eugraulis mordax* Girard. Journal of Experimental Marine Biology and Ecology. 25, 285-312.
- O'Brien-MacDonald, K., Brown, J.A., Parrish, C.C., 2006. Growth, behaviour, and digestive enzyme activity in larval Atlantic cod (*Gadus morhua*) in relation to rotifer lipid. ICES Journal of Marine Science. 63, 275-284.
- Oca, J., Masaló, I., Reig, L., 2004. Comparative analysis of flow patterns in aquaculture rectangular tanks with different water inlet characteristics. Aquacultural Engineering. 31, 221-236.

- Ofelio, C., Blanco, A., Roura, Á., Pintado, J., Pascual, S., Planas, M., 2013. Isolation and molecular identification of the scuticociliate *Porpostoma notata* Moebius, 1888 from moribund reared *Hippocampus hippocampus* (L.) seahorses, by amplification of the SSU rRNA gene sequences. *Journal of Fish Diseases*.
- Olivier, K., 2008. World trade in ornamental species, *Marine Ornamental Species*. In: Cato J.C. and Brown C.L. (ed.). *Marine Ornamental Species: Collection, Culture & Conservation*. Blackwell Publishing Company, 49-64 pp.
- Olivotto, I., Avella, M.A., Sampaolesi, G., Piccinetti, C.C., Navarro Ruiz, P., Carnevali, O., 2008. Breeding and rearing the longsnout seahorse *Hippocampus reidi*: Rearing and feeding studies. *Aquaculture*. 283, 92-96.
- Olivotto, I., Holt, S.A., Carnevali, O., Holt, J.G., 2006. Spawning, early development and first feeding in the Lemonpeel angelfish *Centropyge flavissimus*. *Aquaculture*, 253, 270-278.
- Olivotto, I., Planas, M., Simões, N., Holt, G.J., Avella, M.A., Calado, R., 2011. Advances in breeding and rearing marine ornamentals. *Journal of the World Aquaculture Society*. 42, 135-166.
- Oshima, M., Kato, Y., Masuda, R., Kimura, S., Yamashita, Y., 2009. Effect of turbulence on feeding intensity and survival of Japanese flounder *Paralichthys olivaceus* pelagic larvae. *Journal of Fish Biology*. 75, 1639-1647.
- Otero-Ferrer, F., Molina, L., Socorro, J., Herrera, R., Fernández-Palacios, H., Soledad Izquierdo, M., 2010. Live prey first feeding regimes for short-snouted seahorse *Hippocampus hippocampus* (Linnaeus, 1758) juveniles. *Aquaculture Research*. 41, e8-e19.
- Otterlei, E., Nyhammer, G., Folkvord, A., Stefansson, S.O., 1999. Temperature- and size-dependent growth of larval and early juvenile Atlantic cod (*Gadus morhua*): a comparative study of Norwegian coastal cod and northeast Arctic cod. *Canadian Journal of Fisheries and Aquatic Sciences*. 56, 2099-2111.
- Ouyang, Z., 2005. Locomotor activity of cultured seahorses. MsC Thesis, University of Tasmania, Launceston, Australia, 98 pp.

- Palma, J., Bureau, D.P., Andrade, J.P., 2011. Effect of different *Artemia* enrichments and feeding protocol for rearing juvenile long snout seahorse, *Hippocampus guttulatus*. *Aquaculture*. 318, 439-443.
- Palma, J., Bureau, D., Andrade, J.P., 2013. The effect of diet on ontogenic development of the digestive tract in juvenile reared long snout seahorse *Hippocampus guttulatus*. *Fish Physiology and Biochemistry*, 1-12.
- Palma, J., Stockdale, J., Correia, M., Andrade, J.P., 2008. Growth and survival of adult long snout seahorse (*Hippocampus guttulatus*) using frozen diets. *Aquaculture*. 278, 55-59.
- Papadakis, I.E., Kentouri, M., Divanach, P., Mylonas, C.C. (2013). Ontogeny of the digestive system of meagre *Argyrosomus regius* reared in a mesocosm, and quantitative changes of lipids in the liver from hatching to juvenile. *Aquaculture*. 388–391, 76-88.
- Partridge, G.J., Benetti, D.D., Stieglitz, J.D., Hutapea, J., McIntyre, A., Chen, B., Hutchinson, W., Scholey, V.P., 2011. The effect of a 24-hour photoperiod on the survival, growth and swim bladder inflation of pre-flexion yellowfin tuna (*Thunnus albacares*) larvae. *Aquaculture*. 318, 471-474.
- Pawar, H., Sanaye, S., Murugan, A., Sreepada, R., 2011. Effect of background color of tanks on growth and survival of juvenile Yellow Seahorse, *Hippocampus kuda* (Bleeker 1852), in the pelagic phase. *Israeli Journal of Aquaculture-Bamidgeh*. 63, 1-6.
- Payne, M.F., 2003. Rearing the coral seahorse, *Hippocampus barbouri*, on live and inert prey. *Marine Ornamental Species: Collection, Culture & Conservation*, 289-296.
- Payne, M., 2005. West Australian or tigersnout seahorse, *Hippocampus subelongatus*. in: Koldewey, H. (ed.), *Syngnathid Husbandry in Public Aquariums 2005 Manual*, London, pp. 85-87.
- Payne, M.F., Rippingale, R.J., 2000. Rearing West Australian seahorse, *Hippocampus subelongatus*, juveniles on copepod nauplii and enriched *Artemia*. *Aquaculture*. 188, 353-361.
- Pérez-Casanova, J.C., Murray, H.M., Gallant, J.W., Ross, N.W., Douglas, S.E., Johnson, S.C., 2006. Development of the digestive capacity in larvae of haddock (*Melanogrammus aeglefinus*) and Atlantic cod (*Gadus morhua*). *Aquaculture*. 251, 377-401.

- Pérez-Ruzafa A., Quispe-Becerra J. I., García-Charton J. A., Marcos, C., 2004. Composition, structure and distribution of the ichthyoplankton in a Mediterranean coastal lagoon. *Journal of Fish Biology*. 64, 202–218.
- Peters, H., 1951. Beiträge zur ökologischen Physiologie des Seepferdes (*Hippocampus brevisrostris*). *Zeitschrift für vergleichende Physiologie*. 33, 207-265.
- Pham, N.K., Lin, J., 2013. The effects of different feed enrichments on survivorship and growth of early juvenile longsnout seahorse, *Hippocampus reidi*. *Journal of the World Aquaculture Society*. 44, 435-446.
- Planas, M., Blanco, A., Chamorro, A., Valladares, S., Pintado, J., 2012. Temperature-induced changes of growth and survival in the early development of the seahorse *Hippocampus guttulatus*. *Journal of Experimental Marine Biology and Ecology*. 438, 154-162.
- Planas, M., Chamorro, A., Quintas, P., Balcázar, J.L., 2008a. Maturation of long-snouted seahorse *Hippocampus guttulatus* females under captive conditions. in: Kampler, E., Dabrowski, K. (Eds.), *Aquaculture 2008*. European Aquaculture Society, Krakow, Poland, pp. 531-532.
- Planas, M., Chamorro, A., Quintas, P., Vilar, A., 2008b. Establishment and maintenance of threatened long-snouted seahorse, *Hippocampus guttulatus*, broodstock in captivity. *Aquaculture*. 283, 19-28.
- Planas, M., Labarta, U., Fernández-Reiríz, M.J., Ferreiro, M.J., Munilla-Morán, R., Garrido, J.L., 1993. Chemical changes during early development in turbot (*Scophthalmus maximus* L.) eggs and larvae. In: Walther, B.T. and Fyhn, H.J. (ed.). *Physiology and biochemistry of fish larval development*. University of Bergen, Norway: Academic Press, 269-278 pp.
- Planas, M., Quintas, P., Chamorro, A., 2009a. Growth of adult seahorses *Hippocampus guttulatus* fed exclusively on enriched adult *Artemia* (Project Hippocampus), *World Aquaculture 2009*, Veracruz, México.
- Planas, M., Quintas, P., Chamorro, A., 2010b. Effect of temperature and photoperiod on female maturation in European seahorses. *European Aquaculture Society, Aquaculture Europe 2010*, 5-8 October 2010, Porto (Portugal).

- Planas, M., Quintas, P., Chamorro, A., 2013. Maturation of *Hippocampus guttulatus* and *Hippocampus hippocampus* females by manipulation of temperature and photoperiod regimes. *Aquaculture*. 388–391, 147-152.
- Planas, M., Quintas, P., Chamorro, A., Balcazar, J.L., 2009b. Husbandry and rearing of the seahorse *Hippocampus guttulatus* (Project Hippocampus). World Aquaculture Society, 25-29 May 2009, Veracruz (México).
- Planas, M., Quintas, P., Chamorro, A., Silva, C., 2010a. Female maturation, egg characteristics and fatty acids profile in the European long-snouted seahorse *Hippocampus guttulatus*. *Animal Reproduction Science*. 122, 66-73.
- Planas, M., Quintas, P., Silva, C., 2009c. Snout abnormalities in young seahorses (*Hippocampus guttulatus*) (Proyecto Hippocampus), World Aquaculture, Veracruz (México).
- Porter, M.M., Novitskaya, E., Castro-Ceseña, A.B., Meyers, M.A., McKittrick, J., 2013. Highly deformable bones: Unusual deformation mechanisms of seahorse armor. *Acta Biomaterialia*. 9, 6763-6770.
- Praet, T., Adriaens, D., Cauter, S.V., Masschaele, B., Beule, M.D., Verheghe, B., 2012. Inspiration from nature: dynamic modelling of the musculoskeletal structure of the seahorse tail. *International journal for numerical methods in biomedical engineering*. 28, 1028-1042.
- Prein, M., 1995. Aquaculture potential of seahorses and pipefishes. *Naga*. 18, 20-21.
- ProjectSeahorse, 2014. Why seahorses? Seahorse biology, Last accessed: 04 March 2014. <http://seahorse.fisheries.ubc.ca/why-seahorses/biology>.
- Quintas, P., Planas, M., Purser, G.J., 2010. Biochemical composition and enzymatic activities in juveniles of the seahorse *Hippocampus abdominalis* and the effect of *Artemia* enrichment, *Aquaculture Europe 2010*, 5-8 October 2010, Port (Portugal).
- Rackmil, M., Messbauer, A., Morgano, M., DeNardo, D., Dierenfeld, E.S., 2009. Investigation into de nutritional composition of moon jellyfish, *Aurelia aurita*. *Drum and Croaker*. 40, 33-47.

- Raj, S.T., Lipton, A., Chauhan, G., 2010. Characterization and infectivity evaluation of *Vibrio harveyi* causing white patch disease among captive reared seahorses, *Hippocampus kuda*. Indian Journal of Marine Sciences. 39, 151-156.
- Rajkumar, M., Kumaraguru, K.P., 2006. Suitability of the copepod, *Acartia clausi* as a live feed for Seabass larvae (*Lates calcarifer* Bloch): Compared to traditional live-food organisms with special emphasis on the nutritional value. Aquaculture. 261, 649-658.
- Reid, A.L., Seebacher, F., Ward, A.J.W., 2010. Learning to hunt: the role of experience in predator success. Behaviour. 147, 223-233.
- Reina-Hervás, J.A., 1989. Contribución al estudio de la F. Syngnathidae (Pises) en las costas del sureste de España. Archivos Museu Bocage 1, 325-334.
- Reynolds, R. W., Smith, T.M., 1995. A high resolution global sea surface temperature climatology, Journal of Climate. 8, 1571-1583.
- Ribeiro, L., Zambonino-Infante, J.L., Cahu, C., Dinis, M.T., 1999. Development of digestive enzymes in larvae of *Solea senegalensis*, Kaup 1858. Aquaculture. 179, 465-473.
- Rønnestad, I., Tonheim, S., Fyhn, H., Rojas-Garcia, C., Kamisaka, Y., Koven, W., Finn, R., Terjesen, B., Barr, Y., Conceição, L., 2003. The supply of amino acids during early feeding stages of marine fish larvae: a review of recent findings. Aquaculture. 227, 147-164.
- Rønnestad, I., Yúfera, M., Ueberschär, B., Ribeiro, L., Sæle, Ø., Boglione, C., 2013. Feeding behaviour and digestive physiology in larval fish: current knowledge, and gaps and bottlenecks in research. Reviews in Aquaculture. 5, S59-S98.
- Roos, G., Leysen, H., VanWassenbergh, S., Herrel, A., Jacobs, P., Dierick, M., Aerts, P., Adriaens, D., 2009a. Linking morphology and motion: A test of a four-bar mechanism in seahorses. Physiological and Biochemical Zoology. 82, 7-19.
- Roos, G., Van Wassenbergh, S., Aerts, P., Herrel, A., Adriaens, D., 2011. Effects of snout dimensions on the hydrodynamics of suction feeding in juvenile and adult seahorses. Journal of Theoretical Biology. 269, 307-317.
- Roos, G., Van Wassenbergh, S., Herrel, A., Adriaens, D., Aerts, P., 2010. Snout allometry in seahorses: insights on optimisation of pivot feeding performance during ontogeny. The Journal of Experimental Biology. 213, 2184-2193.

- Roos, G., Van Wassenbergh, S., Herrel, A., Aerts, P., 2009b. Kinematics of suction feeding in the seahorse *Hippocampus reidi*. *Journal of Experimental Biology*. 212, 3490-3498.
- Ross, R.M., Watten, B.J., Krise, W.F., DiLauro, M.N., Soderberg, R.W., 1995. Influence of tank design and hydraulic loading on the behavior, growth, and metabolism of rainbow trout (*Oncorhynchus mykiss*). *Aquacultural Engineering*. 14, 29-47.
- Rosenthal, H., Hempel, G., 1970. Experimental studies in feeding and food requirements of herring larvae (*Clupea harengus* L.). In: Steele, J.H. (ed.). *Marine Food Chains*. Oliver and Boys, Edinburgh, 344-364 pp.
- Rosenthal, H., 1989. Fish behaviour in circular tanks: a video documentation on fish distribution and water quality. In: Lillelund, K. and Rosenthal, H. (ed.). *Fish health protection strategies*. Federal Ministry for Research and Technology, Hamburg, Germany, 161-166 pp.
- Saavedra, M., Masdeu, M., Hale, P., Sibbons, C., Holt, W., 2013. Dietary fatty acid enrichment increases egg size and quality of yellow seahorse *Hippocampus kuda*. *Animal Reproduction Science*. 145, 54-61.
- Sakakura, Y., Shiotani, S., Chuda, H., Hagiwara, A., 2006. Improvement of the survival in the seven-band grouper *Epinephelus septemfasciatus* larvae by optimizing aeration and water inlet in the mass-scale rearing tank. *Fisheries Science*. 72, 939-947.
- Sakakura, Y., Shiotani, S., Shiozaki, M., Hagiwara, A., 2007. Larval rearing without aeration: a case study of the seven-band grouper *Epinephelus septemfasciatus* using a wave maker. *Fisheries Science*. 73, 1199-1201.
- Sales, J., Janssens, G.P., 2003. Nutrient requirements of ornamental fish. *Aquatic Living Resources*. 16, 533-540.
- Sanz, A., Llorente, J.I., Furné, M., Ostos-Garrido, M.V., Carmona, R., Domezain, A., Hidalgo, M.C., 2011. Digestive enzymes during ontogeny of the sturgeon *Acipenser naccarii*, intestine and pancreas development. *Journal of Applied Ichthyology*. 27, 1139-1146.
- Sargent, J.R., Henderson, R.J., Tocher, D.R., 1989. The lipids. In: Halver, J. (ed.). *Fish Nutrition*, 2nd edn. Academic Press, New York, USA. 153–218 pp.

- Sargent, J., McEvoy, L., Bell, J., 1997. Requirements, presentation and sources of polyunsaturated fatty acids in marine fish larval feeds. *Aquaculture*. 155, 117-127.
- Sargent, J., McEvoy, L., Estévez, A., Bell, G., Bell, M., Henderson, J., Tocher, D., 1999. Lipid nutrition of marine fish during early development: current status and future directions. *Aquaculture*. 179, 217–229
- Scharf, F.S., Juanes, F., Rountree, R.A., 2000. Predator size-prey size relationships of marine fish predators: interspecific variation and effects of ontogeny and body size on trophic-niche breadth. *Marine Ecology Progress Series*. 208, 229-248.
- Schipp, G., 2006. The use of calanoid copepods in semi-intensive, tropical marine fish larviculture. In: Cruz Suárez, L., Marie, D., Salazar, M., Nieto López, M., Villarreal Cavazos, D. (ed.). *Avances en nutrición acuicola VIII*. Universidad Autónoma de Nuevo León, Monterrey, Nuevo León, México, 84-94 pp.
- Schipp, G.R., Bosmans, J.M., Marshall, A.J., 1999. A method for hatchery culture of tropical calanoid copepods, *Acartia* spp. *Aquaculture*. 174, 81-88.
- Selman, K., Wallace, R.A., Player, D., 1991. Ovary of the seahorse, *Hippocampus erectus*. *Journal of Morphology*. 209, 285-304.
- Shapawi, R., Purser, G.J., 2003. The value of enriched *Artemia* in supporting growth and survival of juvenile Pot-bellied seahorses *Hippocampus abdominalis*. *Journal of the World Aquaculture Society*. 34, 533-541.
- Shaw, G.W., Pankhurst, P.M., Purser, G.J., 2003. Prey selection by greenback flounder *Rhombosolea tapirina* (Günther) larvae. *Aquaculture*. 228, 249-265.
- Sheng, J., Lin, Q., Chen, Q., Gao, Y., Shen, L., Lu, J., 2006. Effects of food, temperature and light intensity on the feeding behavior of three-spot juvenile seahorses, *Hippocampus trimaculatus* Leach. *Aquaculture*. 256, 596-607.
- Sheng, J., Lin, Q., Chen, Q., Shen, L., Lu, J., 2007. Effect of starvation on the initiation of feeding, growth and survival rate of juvenile seahorses, *Hippocampus trimaculatus* Leach and *Hippocampus kuda* Bleeker. *Aquaculture*. 271, 469-478.
- Shin, S.P., Han, J.E., Gomez, D.K., Kim, J.H., Choresca Jr, C.H., Jun, J.W., Park, S.C., 2011. Identification of scuticociliate *Philasterides dicentrarchi* from indo-pacific seahorses *Hippocampus kuda*. *African Journal of Microbiology Research*. 5, 738-741.

- Skiftesvik, A.B., 1992. Changes in behaviour at onset of exogenous feeding in marine fish larvae. *Canadian Journal of Fisheries and Aquatic Sciences*. 49, 1570-1572.
- Smith, R., Grutter, A., Tibbetts, I., 2012. Extreme habitat specialisation and population structure of two gorgonian-associated pygmy seahorses. *Marine Ecology Progress Series*. 444, 195-206.
- Smith, W., 1870. *Dictionary of Greek and Roman biography and mythology*. Little, Boston.
- Sommer, S., Whittington, C.M., Wilson, A.B., 2012. Standardised classification of pre-release development in male-brooding pipefish, seahorses, and seadragons (Family Syngnathidae). *BMC developmental biology*. 12, 39.
- Sorgeloos, P., 2013. *Aquaculture: The Blue Biotechnology of the Future*. In: Society, W.A. Available at: <https://www.was.org/articles/Aquaculture-blue-biotechnology-of-the-future.aspx#.UsbdJvTuKSo> Accessed in March 2014.
- Sorgeloos, P., Dhert, P., Candreva, P., 2001. Use of the brine shrimp, *Artemia* spp., in marine fish larviculture. *Aquaculture*. 200, 147-159.
- Souza-Santos, L.P., Regis, C.G., Mélo, R.C.S., Cavalli, R.O., 2013. Prey selection of juvenile seahorse *Hippocampus reidi*. *Aquaculture*. 404–405, 35-40.
- Sprung, M., 1994. Macrobenthic secondary production in the intertidal zone of Ria Formosa-a lagoon in southern Portugal. *Estuarine, Coastal and Shelf Science*. 38, 539–558.
- Srichanun, M., Tantikitti, C., Vatanakul, V., Musikarune, P., 2012. Digestive enzyme activity during ontogenetic development and effect of live feed in green catfish larvae (*Mystus nemurus* Cuv. & Val.). *Songklanakarin Journal of Science and Technology*. 34, 247-254.
- Stölting, K.N., Wilson, A.B., 2007. Male pregnancy in seahorses and pipefish: beyond the mammalian model. *BioEssays*. 29, 884-896.
- Støttrup, J.G., Richardson, K., Kirkegaard, E., Pihl, N.J., 1986. The cultivation of *Acartia tonsa* Dana for use as a live food source for marine fish larvae. *Aquaculture*. 52, 87-96.
- Strawn, K., 1958. Life history of the pigmy seahorse, *Hippocampus zosterae* Jordan and Gilbert, at Cedar Key, Florida. *Copeia*, 16-22.
- Stuart, K.R., Drawbridge, M., 2012. The effect of photoperiod on larval culture performance of two marine finfish species. *Aquaculture*. 360–361, 54-57.

- Sundby, S., 2000. Recruitment of Atlantic cod stocks in relation to temperature and advection of copepod populations. *Sarsia* 85, 277-298.
- Teixeira, R., Musick, J., 2001. Reproduction and food habits of the lined seahorse, *Hippocampus erectus* (Teleostei: Syngnathidae) of Chesapeake Bay, Virginia. *Revista Brasileira de Biologia*. 61, 79-90.
- Tendencia, E.A., 2004. The first report of *Vibrio harveyi* infection in the sea horse *Hippocampus kuda* Bleekers 1852 in the Philippines. *Aquaculture Research*. 35, 1292-1294.
- Teske, P.R., Beheregaray, L.B., 2009. Evolution of seahorses' upright posture was linked to Oligocene expansion of seagrass habitats. *Biology Letters*. 5, 521-523.
- Theilacker, G.H., 1978. Effect of starvation on the histological and morphological characteristics of jack mackerel, *Trachurus symmetricus*, larvae. *Fisheries Bulletin*. 76, 403-414.
- Thuong, T.D., Hoang, T., 2013. Rearing the spotted seahorse *Hippocampus kuda* by feeding live and frozen copepods collected from shrimp ponds. *Aquaculture Research*, 1-7.
- Tipton, K., Bell, S.S., 1988. Foraging patterns of two syngnathid fishes: importance of harpacticoid copepods. *Marine Ecology Progress Series*. 47, 31-43.
- Thlusty, M., 2002. The benefits and risks of aquacultural production for the aquarium trade. *Aquaculture*. 205, 203-219.
- Thlusty, M.F., Goldstein, J.s., Fiore, D.R., 2005. Hatchery performance of early benthic juvenile American lobster (*Homarus americanus*) fed enriched frozen adult *Artemia* diets. *Aquaculture Nutrition*. 11, 191-198.
- Townsend, C., Winfield, I., 1985. The application of optimal foraging theory to feeding behaviour in fish. In: Tytler, P. and Calow, P. (ed.), *Fish Energetics*. Springer, Netherlands, 67-98 pp.
- Turner, J.P., Rooker, J.R., 2005. Effect of dietary fatty acids on the body tissues of larval and juvenile cobia and their prey. *Journal of Experimental Marine Biology and Ecology*. 322, 13-27.
- Urtizberea, A., Fiksen, Ø., 2013. Effects of prey size structure and turbulence on feeding and growth of anchovy larvae. *Environmental Biology of Fishes*. 96, 1045-1063.

- Utne-Palm, A.C., Stiansen, J.E., 2002. Effect of larval ontogeny, turbulence and light on prey attack rate and swimming activity in herring larvae. *Journal of Experimental Marine Biology and Ecology*. 268, 147-170.
- Vallés, R., Estévez, A., 2013. Light conditions for larval rearing of meagre (*Argyrosomus regius*). *Aquaculture*. 376–379, 15-19.
- Van Cauwer, S., Adriaens, D., Kannan, S., Srirajulu, S., Praet, T., Masschaele, B., De Beule, M., Verheghe, B., 2010. Virtual design from nature: kinematic modeling of the seahorse tail, 2010 SIMULIA Customer Conference Proceedings, pp. 770-783.
- Vanechoutte, M., Verschraegen, G., Claeys, G., Flamen, P., 1988. Rapid identification of *Branhamella catarrhalis* with 4-methylumbelliferyl butyrate. *Journal of Clinical Microbiology*. 26, 1227–1228
- Van Wassenbergh, S., Leysen, H., Adriaens, D., Aerts, P., 2013. Mechanics of snout expansion in suction-feeding seahorses: musculoskeletal force transmission. *The Journal of Experimental Biology*. 216, 407-417.
- Van Wassenbergh, S., Roos, G., Ferry, L., 2011. An adaptive explanation for the horse-like shape of seahorses. *Nature Communications*. 2.
- Van Wassenbergh, S., Roos, G., Genbrugge, A., Leysen, H., Aerts, P., Adriaens, D., Herrel, A., 2009. Suction is kid's play: extremely fast suction in newborn seahorses. *Biology Letters*. 5, 200-203.
- Verreth, J., 1994. Nutritional and related ontogenetic aspects in larvae of the African catfish, *Clarias gariepinus*. DSc Thesis, Wageningen Agricultural University, Wageningen, 203 pp.
- Viciano, E., Monroig, Ó., Salvador, A., Amat, J., Fiszman, S., Navarro, J.C., 2013. Enriching *Artemia* nauplii with a high DHA-containing lipid emulsion: search for an optimal protocol. *Aquaculture Research*. 1-12
- Vincent, A.C.J., 1990. Reproductive ecology of seahorses. PhD thesis, Coprus Christi College, University of Cambridge, Cambridge, UK, 101pp.
- Vincent, A.C.J., 1996. The international trade in seahorses. TRAFFIC International.
- Vincent, A.C.J., Ahnesjö, I., Berglund, A., 1994. Operational sex ratios and behavioural sex differences in a pipefish population. *Behavioral Ecology and Sociobiology*. 34, 142-435.

- Vincent, A.C.J., Ahnesjö, I., Berglund, A., Rosenqvist, G., 1992. Pipefishes and seahorses: Are they all sex role reversed? *Trends in Ecology & Evolution*. 7, 237-241.
- Vincent, A.C.J., Clifton-Hadley, R.S., 1989. Parasitic infection of the seahorse (*Hippocampus erectus*): a case report. *Journal of wildlife diseases*. 25, 404-406.
- Vincent, A.C.J., Koldewey, H., 2006. An uncertain future for seahorse aquaculture in conservation and economic contexts, *Proceedings of the Regional Technical Consultation on Stock Enhancement of Species Under International Concern*. 13-15 July 2005, Iloilo City (Philippines).
- Vincent, A.C.J., Sadler, L.M., 1995. Faithful pair bonds in wild seahorses, *Hippocampus whitei*. *Animal Behaviour*. 50, 1557-1569.
- Wahl, D.H., Einfalt, L.M., Hooe, M.L., 1995. Effect of experience with piscivory on foraging behavior and growth of walleyes. *Transactions of the American Fisheries Society*. 124, 756-763.
- Walford, J., Lam, T.J., 1993. Development of digestive tract and proteolytic enzyme activity in seabass (*Lates calcarifer*). larvae and juveniles. *Aquaculture*. 109, 187-205.
- Walters, K., Coen, L.D., 2006. A comparison of statistical approaches to analyzing community convergence between natural and constructed oyster reefs. *Journal of Experimental Marine Biology and Ecology*. 330, 81-95.
- Wardley, R.T., 2006. A Study on the Feeding of the Pot-bellied Seahorse (*Hippocampus abdominalis*): Reducing the Reliance on Brine Shrimp (*Artemia*). PhD Thesis, University of Tasmania, Australia, 634 pp.
- Waxman, S., 2008. Chasing the Lydian hoard. Available at: <http://www.smithsonianmag.com/history/chasing-the-lydian-hoard-93685665/?no-ist=>. Accessed in March 2014.
- Weltzien, F.-A., Planas, M. Fyhn, H.J., 1999. Temperature dependency of early growth of turbot (*Scoththalmus maximus*) and its implications for developmental progress. *Journal of Experimental Marine Biology and Ecology*. 242, 201-210.
- Wheeler, A.C., Merrett, N.R., Quigley, D.T.G., 2004. Additional records and notes for Wheeler's (1992) List of the Common and Scientific Names of Fishes of the British Isles. *Journal of Fish Biology*. 65, 1-40.

- Whitfield, A.K., 1995. Threatened fishes of the world: *Hippocampus capensis* Boulenger, 1900 (Syngnathidae). *Environmental Biology of Fishes*. 44, 362-362.
- Widmer, C.L., Voorhees, J.P., Badger, M.A., Lambert, J.W., Block, N.M., 2005. The effects of rearing vessels and laboratory diets on growth of northeast pacific jellyfish ephyrae (Cnidaria: Scyphozoa). *Drum and Croaker*. 36, 29-36.
- Wilson, A., Martin-Smith, K.M., 2007. Genetic monogamy despite social promiscuity in the pot-bellied seahorse (*Hippocampus abdominalis*). *Molecular ecology*. 16, 2345-2352.
- Wilson, A.B., Orr, J.W., 2011. The evolutionary origins of Syngnathidae: pipefishes and seahorses. *Journal of Fish Biology*. 78, 1603-1623.
- Wilson, M., Vincent, A.J., 2000. Preliminary success in closing the life cycle of exploited seahorse species, *Hippocampus* spp., in captivity. *Aquarium Sciences and Conservation*. 2, 179-196.
- Wilson, A.B., Vincent, A.J., Ahnesjö, I., Meyer, A., 2001. Male pregnancy in seahorses and pipefishes (family Syngnathidae): rapid diversification of paternal brood pouch morphology inferred from a molecular phylogeny. *Journal of Heredity*. 92, 159-166.
- Willadino, L., Souza-Santos, L.P., Mélo, R.C.S., Brito, A.P., Barros, N.C.S., Araújo-Castro, C.M.V., Galvão, D.B., Gouveia, A., Regis, C.G., Cavalli, R.O., 2012. Ingestion rate, survival and growth of newly released seahorse *Hippocampus reidi* fed exclusively on cultured live food items. *Aquaculture*. 360–361, 10-16.
- Willens, S., Dunn, J.L., Frasca Jr, S., 2004. Fibrosarcoma of the brood pouch in an aquarium-reared lined seahorse (*Hippocampus erectus*). *Journal of Zoo and Wildlife Medicine*. 35, 107-109.
- Wolff, W.J., 2000. The south-eastern North Sea: losses of vertebrate fauna during the past 2000 years. *Biological Conservation*. 95, 209-217.
- Wong, J.M., Benzie, J.A.H., 2003. The effects of temperature, *Artemia* enrichment, stocking density and light on the growth of juvenile seahorses, *Hippocampus whitei* (Bleeker, 1855), from Australia. *Aquaculture*. 228, 107-121.
- Woodall L., 2009. Population genetics and mating systems of European seahorses *Hippocampus guttulatus* and *Hippocampus hippocampus*. PhD Thesis, University of London, Royal Holloway, UK.

- Woods, C.M.C., 2000a. Improving initial survival in cultured seahorses, *Hippocampus abdominalis* Leeson, 1827 (Teleostei: Syngnathidae). *Aquaculture*. 190, 377-388.
- Woods, C.M.C., 2000b. Preliminary observations on breeding and rearing the seahorse *Hippocampus abdominalis* (Teleostei: Syngnathidae) in captivity. *New Zealand Journal of Marine and Freshwater Research*. 34, 475-485.
- Woods, C.M.C., 2002. Natural diet of the seahorse *Hippocampus abdominalis*. *New Zealand Journal of Marine and Freshwater Research*. 36, 655-660.
- Woods, C.M.C., 2003a. Effects of varying *Artemia* enrichment on growth and survival of juvenile seahorses, *Hippocampus abdominalis*. *Aquaculture*. 220, 537-548.
- Woods, C.M.C., 2003b. Effect of stocking density and gender segregation in the seahorse *Hippocampus abdominalis*. *Aquaculture*. 218, 167-176.
- Woods, C.M.C., 2003c. Growth and survival of juvenile seahorse *Hippocampus abdominalis* reared on live, frozen and artificial foods. *Aquaculture*. 220, 287-298.
- Woods, C.M.C., 2007. Aquaculture of the Big-bellied seahorse *Hippocampus abdominalis* Lesson 1827 (Teleostei: Syngnathidae). PhD Thesis, Victoria University of Wellington, Victoria (Australia), pp. 250.
- Yin, M.C., Blaxter, J.H.S., 1987. Feeding ability and survival during starvation of marine fish larvae reared in the laboratory. *Journal of Experimental Marine Biology and Ecology*, 105, 73-83.
- Yin, F., Tang, B., Zhang, D., Zou, X., 2012. Lipid metabolic response, peroxidation, and antioxidant defence status of juvenile lined seahorse, *Hippocampus erectus*, fed with highly unsaturated fatty acids enriched *Artemia* nauplii. *Journal of the World Aquaculture Society*. 43, 716-726.
- Yúfera, M., Darias, M.J., 2007. The onset of exogenous feeding in marine fish larvae. *Aquaculture*. 268, 53-63.
- Yúfera, M., Pascual, E., Polo, A., Sarasquete, M.C., 1993. Effect of starvation on the feeding ability of gilthead seabream, *Sparus aurata* L. larvae at first feeding. *Journal of Experimental Marine Biology and Ecology*. 169, 259-272.

- Žalohar, J., Hitij, T., 2012. The first known fossil record of pygmy pipehorses (Teleostei: Syngnathidae: Hippocampinae) from the Miocene coprolitic horizon, Tunjice Hills, Slovenia, *Annales de Paléontologie*. Elsevier, pp. 131-151.
- Žalohar, J., Hitij, T., Križnar, M., 2009. Two new species of seahorses (Syngnathidae, Hippocampus) from the Middle Miocene (Sarmatian) Coprolitic Horizon in Tunjice Hills, Slovenia: The oldest fossil record of seahorses, *Annales de paléontologie*. Elsevier, pp. 71-96.
- Zambonino Infante, J.L., Cahu, C.L., 2001. Ontogeny of the gastrointestinal tract of marine fish larvae. *Comparative Biochemistry and Physiology: Part C*. 130, 477-487.
- Zhang, D., Zhang, Y., Lin, J., Lin, Q., 2010. Growth and survival of juvenile lined seahorse, *Hippocampus erectus* (Perry), at different stocking densities. *Aquaculture Research*. 42, 9-13.
- Zhang, D., Yin, F., Lin, J., 2011. Criteria for assessing juvenile quality of the lined seahorse, *Hippocampus erectus*. *Aquaculture*. 322–323, 255-258.

ANNEXES

ANNEX I



Short Communication

First observations of conjoined twins in newborn seahorses, *Hippocampus guttulatus* Cuvier

A Blanco, P Quintas and M Planas

Instituto Investigaciones Marinas (CSIC), Eduardo Cabello, Vigo, Spain

Keywords: conjoined twins, *Hippocampus guttulatus*, seahorses.

Occurrence of conjoined twins or two-headed fish is not uncommon (Hanson 1985), being generally more frequent under artificial conditions than in nature (Owusu-Frimpong & Hargreaves 2000). The origin of conjoined twins can be natural, occurring when two centres of development arise from one germ ring (Laale 1984), or teratogenic, by environmental pollution or toxicity by mutagenic chemicals in the water (Herrmann 1995; Al-Jufaily, Laith & Al-Az 2005). Since the first recorded case of conjoined twins among fish in *Carassius* sp. (Jussieu 1754), twinning has been also reported in fish species such as *Oncorhynchus keta* (Walbaum) (Yamamoto, Kobayashi & Kuramoto 1996), *Oreochromis aureus* (Steindachner) and *Oreochromis niloticus* (L.) (Owusu-Frimpong & Hargreaves 2000), *Arius dussumieri* (Valenciennes) (Al-Jufaily *et al.* 2005) and *Brachydanio rerio* (Hamilton) (Herrmann 1995), among other species, both in the wild and under laboratory or farmed conditions (Pavis 1961; Hanson 1985; Al-Jufaily *et al.* 2005). Twinning in fish of the family Syngnathidae has been previously described in the pipefish, *Syngnathus floridae* (Jordan & Gilbert) (Cable 1940), but not in seahorses. In this study, three sets of twins were released in the laboratory from pregnant long-snouted seahorses, *Hippocampus guttulatus* Cuvier.

This finding is the first record of conjoined twins in seahorses.

Three males (N81, N104 and N105) of long-snouted seahorses were hand-caught collected in August and September 2010 in the coast of Galicia (NW Spain) and maintained in captivity under photoperiod and temperature regimes (maximum 20 °C) simulating natural conditions during the breeding season. Seahorses were fed on enriched adult *Artemia* (EG-brand, Inve Aquaculture, S.A.) (Planas *et al.* 2008) supplemented with wild caught shrimps (*Leptomysis* sp. and *Siriella* sp.). Male N81 mated in the laboratory, but males N104 and N105 were already pregnant when collected in the wild.

The first release of newborns was recorded in July 2010 (N81). A set of conjoined twins (CT1) was collected together with 500 well-developed newborns, eight eggs and eight premature seahorses. The second and third batches of newborns (N104 and N105, respectively) were released in August and September 2010, respectively. The second batch was composed of 371 well-developed newborns, 128 dead premature seahorses and three live premature seahorses. The third batch consisted of 355 well-developed newborns, 50 premature seahorses and nine embryos. Two conjoined twins (CT2 and CT3, respectively) were also released with each batch.

Biometrical analyses were performed in conjoined twins following the standard seahorse measurement protocol (Lourie, Vincent & Hall 1999). Measurements were made from photographs taken under a stereomicroscope (Nikon) and using the software package NIS-Elements (Nikon). Seahorse standard length (SL) was calculated as the sum of

Correspondence A Blanco, Instituto Investigaciones Marinas (CSIC), Eduardo Cabello, 6. 36211. Vigo, Spain
(e-mail: andreublanco@iim.csic.es)

body length and head length. Body length was measured from the tip of the tail to the ridge of the operculum and head length from the tip of the snout to the ridge of the operculum. In addition, trunk length (from the ridge of the operculum to immediately below the dorsal fin), tail length (from the tip of the tail to immediately below the dorsal fin), dorsal fin length (from the upper to the lowest tip of the fin), head fusion length (Hf; from the fusion point of the twins to the top of the head) and tail fusion length (Tf; from the fusion point of the twins to the tip of the tail) were also measured.

Newborn twins were in the post-yolk-sac-stage and alive after birth. CT1 and CT2 twins were normally developed, but ventrally fused and with a shared tail (Fig. 1a,b). Conversely, twins CT3 were non-fully developed and unequal in size (Fig. 1c).

The results of the measurements performed are summarized in Table 1. The SL in all twins was

smaller than that of the normally developed *H. guttulatus* newborns (Planas *et al.* 2009). In CT1, each twin had its own pectoral and dorsal fin and a unique well-developed tail. On the other hand, in CT2, a deformation of spinal axis was present (Fig. 1b), which showed a separated well-developed head, a fused trunk from the jaw and a completely deformed and twisted tail. Differences in size between both twins in CT3 agree with what generally occurs in twin pairs (Hanson 1985), where one of the twins is much smaller than the other. The smaller twin showed an underdeveloped head, which appeared to be fused to the abdominal region of the other twin.

All twins were processed for histological analysis and submitted to differential staining procedures. Seahorses were fixed overnight at 4 °C in methanol containing 2.5% paraformaldehyde and 5% acetic acid and embedded in paraffin. Sections of 2 µm were stained with the Masson's trichrome technique (Masson 1929), and sections of 3 µm were stained with haematoxylin–eosin. Only histological sections of CT1 provided a clear fusion point between twins and more accurate histological cuts.

Histological cuts showed a clear fusion point of the spinal cord in CT1 (Fig. 2a,b). Figure 2b shows a deformation in the backbone of the twins with two additional vertebrae at the fusion point. Figure 2a,b also shows the presence of two kidneys (K_1 and K_2) with a shared anus (AN).

The cause of conjoining in twins is a phenomenon that has been the subject of discussion for a long time (Laale 1984), and it is known that several causes are responsible for conjoining (Arbuatti, Salda & Romanucci 2011). As for most abnormalities in early developmental stages of fish, the occurrence of twinning can be attributed to different causes, such as egg over-ripening (Witschi 1952), pollutants, low dissolved oxygen levels or thermal shock induction (Owusu-Frimpong & Hargreaves 2000). The formation of multiple development centres in eggs, probably due to any disturbance during the early development axis formation, results in polyembryony (Laale 1984; Arbuatti *et al.* 2011). In this regard, it has been suggested that the main cause of polyembryony is environmental stress (Kaufman 2004; Arbuatti *et al.* 2011) during development, both in oviparous (Herrmann 1995; Owusu-Frimpong & Hargreaves 2000; Al-Jufaily *et al.* 2005) and ovoviviparous fish (Cable 1940; Arbuatti *et al.* 2011). It has been demonstrated in the laboratory that wild fish are sensitive to possible teratogenic

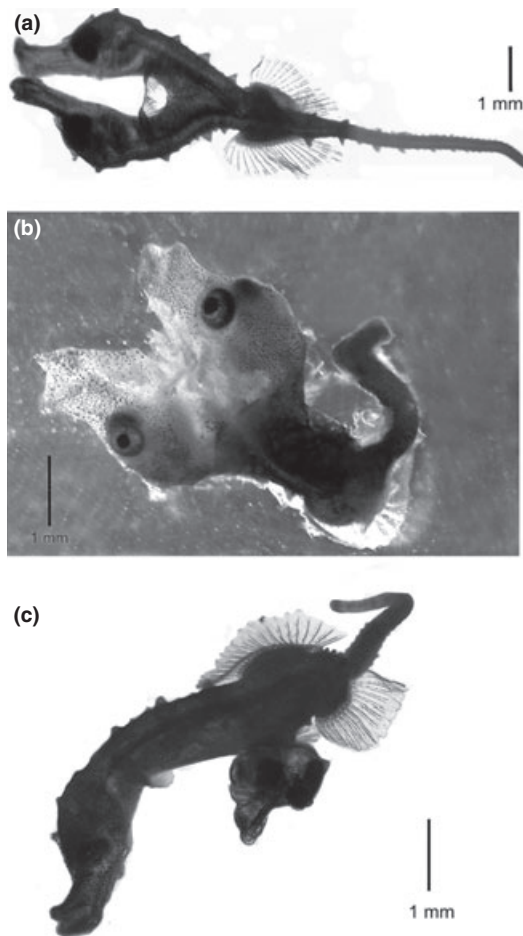

Figure 1 Conjoined-twins CT1, CT2 and CT3.

Table 1 Biometrics (length in mm) in conjoined twins CT1, CT2 and CT3

	SL	Head	Trunk	Tail	Dorsal fin	Hf	Tf
CT1	11.42	2.80–2.99	3.65–3.27	5.18	2.05–2.63	3.61	7.83
CT2	7.76	2.59–2.78	2.33	2.69	2.13–nd	1.44	6.32
CT3	6.24	2.02–1.71	3.74–nd	2.50	2.34–1.35	3.74–0	4.12

Hf and Tf, distance from the twin's fusion point to head and tail, respectively; nd, not determined (impossible to measure); SL, standard length.

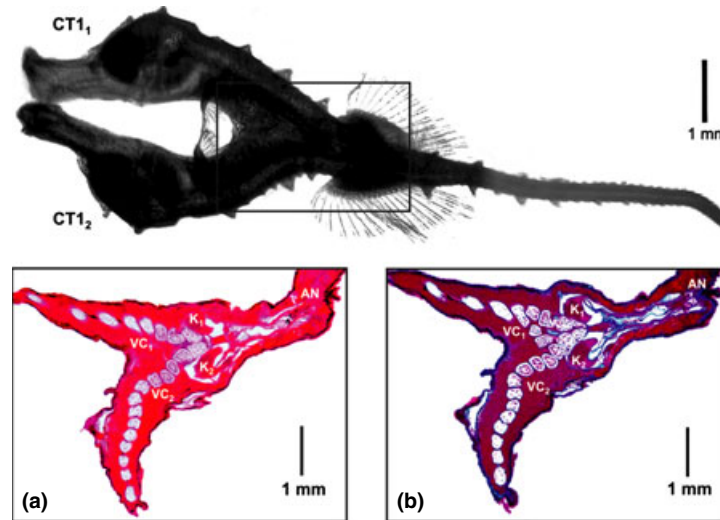

Figure 2 Histological sections in CT1 showing the fusion point of twins (CT1₁ and CT1₂). (a) Haematoxylin-eosin staining. (b) Masson's trichrome staining. VC, vertebral column; K, kidney; AN, anus.

effects causing mitotic abnormalities on embryos or specific locus mutations during oogenesis and spermatogenesis (Longwell *et al.* 1992). However, polyembryony in fish also occurs in nature (Laale 1984).

Twins described in this study corresponded to monozygotic conjoined twins, morphologically described as *anadidyms* type (Laale 1984), as they were two-headed but shared a unique tail. Besides this, twins CT1 and CT2 were also normally shaped seahorses (*autosita* type), whereas twins CT3 were *parasita* type, in which one of the twins is a parasite-like of the other normally shaped twin (Laale 1984). The occurrence of twin conjoining in fish of the Syngnathidae family has been already reported in an embryo of the pipefish *S. floridae* (Cable 1940), but our observations are the first record of this feature in seahorses.

Acknowledgements

We are grateful to the Spanish Government (Plan Nacional, CGL2009-08386) and Xunta de Galicia (09MDS022402PR) for the financial support.

Thanks to J.M. Antonio for his help with the histological analysis. Thanks to A. Chamorro, T. Hermelo and S. Valladares for their assistance. A. Blanco and P. Quintas were granted by CSIC (JAE-Pre and JAE-Doc grants, respectively).

References

- Al-Jufaily S.M., Laith A.J. & Al-Az A.N. (2005) Wild conjoined-twins in black tip sea catfish, *Arius dussumieri* (Valenciennes, 1840) from Gulf of Oman. *Anales de Biología* **27**, 223–225.
- Arbuatti A., Salda L. & Romanucci M. (2011) Histological observations on conjoined twins occurring among a captive-bred wild line of *Poecilia wingei* (Poeser, Kempkes & Isbrücker). *Journal of Fish Diseases* **34**, 319–321.
- Cable L.E. (1940) A two-headed embryo of the pipefish, *Syngnathus floridae*. *Journal of the Elisha Mitchell Scientific Society* **56**, 135–139.
- Hanson L.H. (1985) Observations on twinning in the sea lamprey (*Petromyzon marinus*) in the laboratory. *Journal of Great Lakes Research* **11**, 549–551.
- Herrmann K. (1995) Teratogenic effects of retinoic acid and related substances on the early development of the zebrafish (*Brachydanio rerio*) as assessed by a novel scoring system. *Toxicology in Vitro* **9**, 267–271.

- Jussieu L.C. (1754) Observation sur deux petit poissons reunis par le ventre. *Memoires de l'Academie Sciences de Paris* **1754**, 30.
- Kaufman M.H. (2004) The embryology of conjoined twins. *Child's Nervous System* **20**, 508–525.
- Laale H.W. (1984) Polyembryony in teleostean fishes: double monstrosities and triplets. *Journal of Fish Biology* **24**, 711–719.
- Longwell A., Chang S., Hebert A., Hughes J. & Perry D. (1992) Pollution and developmental abnormalities of Atlantic fishes. *Environmental Biology of Fishes* **35**, 1–21.
- Lourie S.A., Vincent A.C.J. & Hall H.J. (1999) *Seahorses: An Identification Guide to the World's Species and their Conservation*. Project seahorse, London, UK, 214 pp.
- Masson P. (1929) Some histological methods. Trichrome staining and their preliminary technique. *Bulletin of the International Association of Medicine* **12**, 75.
- Owusu-Frimpong M. & Hargreaves J.A. (2000) Incidence of conjoined twins in tilapia after thermal shock induction of polyploidy. *Aquaculture Research* **31**, 421–426.
- Pavis G.W. (1961) Embryological stages in the sea lamprey and effects of the temperature on development. *United States Fish and Wildlife Service Fishery Bulletin* **61**, 111–143.
- Planas M., Chamorro A., Quintas P. & Vilar A. (2008) Establishment and maintenance of threatened long-snouted seahorse, *Hippocampus guttulatus*, broodstock in captivity. *Aquaculture* **283**, 19–28.
- Planas M., Quintas P., Chamorro A. & Balcazar J.L. (2009) Husbandry and rearing of the seahorse *Hippocampus guttulatus* (Project Hippocampus). World Aquaculture Society, World Aquaculture 2009, 25–29 PubMed September 2009, Veracruz (México).
- Witschi E. (1952) Overripeness of the egg as a cause of twinning and teratogenesis: a review. *Cancer Research* **12**, 763–786.
- Yamamoto T.S., Kobayashi W. & Kuramoto T. (1996) Twin malformation induced in chum salmon eggs by elevated water temperature, with a suggestion as to its mechanism. *Canadian Journal of Zoology* **74**, 485–491.

Received: 17 February 2012

Revised received: 12 March 2012

Accepted: 20 March 2012

**JOHN WILEY AND SONS LICENSE
TERMS AND CONDITIONS**

Mar 12, 2014

This is a License Agreement between Andreu Blanco ("You") and John Wiley and Sons ("John Wiley and Sons") provided by Copyright Clearance Center ("CCC"). The license consists of your order details, the terms and conditions provided by John Wiley and Sons, and the payment terms and conditions.

All payments must be made in full to CCC. For payment instructions, please see information listed at the bottom of this form.

License Number	3346521360708
License date	Mar 12, 2014
Licensed content publisher	John Wiley and Sons
Licensed content publication	Journal of Fish Diseases
Licensed content title	First observations of conjoined twins in newborn seahorses, Hippocampus guttulatus Cuvier
Licensed copyright line	© 2012 Blackwell Publishing Ltd
Licensed content author	A Blanco,P Quintas,M Planas
Licensed content date	May 14, 2012
Start page	705
End page	708
Type of use	Dissertation/Thesis
Requestor type	Author of this Wiley article
Format	Print and electronic
Portion	Full article
Will you be translating?	No
Title of your thesis / dissertation	Rearing of the seahorse Hippocampus guttulatus: key factors involved in growth and survival
Expected completion date	May 2014
Expected size (number of pages)	300
Total	0.00 USD
Terms and Conditions	

TERMS AND CONDITIONS

This copyrighted material is owned by or exclusively licensed to John Wiley & Sons, Inc. or one of its group companies (each a "Wiley Company") or a society for whom a Wiley Company has exclusive publishing rights in relation to a particular journal (collectively "WILEY"). By clicking "accept" in connection with completing this licensing transaction, you agree that the following terms and conditions apply to this transaction (along with the billing and payment terms and conditions established by the Copyright Clearance Center Inc., ("CCC's Billing and Payment terms and

conditions"), at the time that you opened your RightsLink account (these are available at any time at <http://myaccount.copyright.com>).

Terms and Conditions

1. The materials you have requested permission to reproduce (the "Materials") are protected by copyright.
2. You are hereby granted a personal, non-exclusive, non-sublicensable, non-transferable, worldwide, limited license to reproduce the Materials for the purpose specified in the licensing process. This license is for a one-time use only with a maximum distribution equal to the number that you identified in the licensing process. Any form of republication granted by this license must be completed within two years of the date of the grant of this license (although copies prepared before may be distributed thereafter). The Materials shall not be used in any other manner or for any other purpose. Permission is granted subject to an appropriate acknowledgement given to the author, title of the material/book/journal and the publisher. You shall also duplicate the copyright notice that appears in the Wiley publication in your use of the Material. Permission is also granted on the understanding that nowhere in the text is a previously published source acknowledged for all or part of this Material. Any third party material is expressly excluded from this permission.
3. With respect to the Materials, all rights are reserved. Except as expressly granted by the terms of the license, no part of the Materials may be copied, modified, adapted (except for minor reformatting required by the new Publication), translated, reproduced, transferred or distributed, in any form or by any means, and no derivative works may be made based on the Materials without the prior permission of the respective copyright owner. You may not alter, remove or suppress in any manner any copyright, trademark or other notices displayed by the Materials. You may not license, rent, sell, loan, lease, pledge, offer as security, transfer or assign the Materials, or any of the rights granted to you hereunder to any other person.
4. The Materials and all of the intellectual property rights therein shall at all times remain the exclusive property of John Wiley & Sons Inc or one of its related companies (WILEY) or their respective licensors, and your interest therein is only that of having possession of and the right to reproduce the Materials pursuant to Section 2 herein during the continuance of this Agreement. You agree that you own no right, title or interest in or to the Materials or any of the intellectual property rights therein. You shall have no rights hereunder other than the license as provided for above in Section 2. No right, license or interest to any trademark, trade name, service mark or other branding ("Marks") of WILEY or its licensors is granted hereunder, and you agree that you shall not assert any such right, license or interest with respect thereto.
5. NEITHER WILEY NOR ITS LICENSORS MAKES ANY WARRANTY OR REPRESENTATION OF ANY KIND TO YOU OR ANY THIRD PARTY, EXPRESS, IMPLIED OR STATUTORY, WITH RESPECT TO THE MATERIALS OR THE ACCURACY OF ANY INFORMATION CONTAINED IN THE MATERIALS, INCLUDING, WITHOUT LIMITATION, ANY IMPLIED WARRANTY OF MERCHANTABILITY, ACCURACY, SATISFACTORY QUALITY, FITNESS FOR A PARTICULAR PURPOSE, USABILITY, INTEGRATION OR NON-INFRINGEMENT AND ALL SUCH WARRANTIES ARE HEREBY EXCLUDED BY WILEY AND ITS LICENSORS AND WAIVED BY YOU.

6. WILEY shall have the right to terminate this Agreement immediately upon breach of this Agreement by you.
7. You shall indemnify, defend and hold harmless WILEY, its Licensors and their respective directors, officers, agents and employees, from and against any actual or threatened claims, demands, causes of action or proceedings arising from any breach of this Agreement by you.
8. IN NO EVENT SHALL WILEY OR ITS LICENSORS BE LIABLE TO YOU OR ANY OTHER PARTY OR ANY OTHER PERSON OR ENTITY FOR ANY SPECIAL, CONSEQUENTIAL, INCIDENTAL, INDIRECT, EXEMPLARY OR PUNITIVE DAMAGES, HOWEVER CAUSED, ARISING OUT OF OR IN CONNECTION WITH THE DOWNLOADING, PROVISIONING, VIEWING OR USE OF THE MATERIALS REGARDLESS OF THE FORM OF ACTION, WHETHER FOR BREACH OF CONTRACT, BREACH OF WARRANTY, TORT, NEGLIGENCE, INFRINGEMENT OR OTHERWISE (INCLUDING, WITHOUT LIMITATION, DAMAGES BASED ON LOSS OF PROFITS, DATA, FILES, USE, BUSINESS OPPORTUNITY OR CLAIMS OF THIRD PARTIES), AND WHETHER OR NOT THE PARTY HAS BEEN ADVISED OF THE POSSIBILITY OF SUCH DAMAGES. THIS LIMITATION SHALL APPLY NOTWITHSTANDING ANY FAILURE OF ESSENTIAL PURPOSE OF ANY LIMITED REMEDY PROVIDED HEREIN.
9. Should any provision of this Agreement be held by a court of competent jurisdiction to be illegal, invalid, or unenforceable, that provision shall be deemed amended to achieve as nearly as possible the same economic effect as the original provision, and the legality, validity and enforceability of the remaining provisions of this Agreement shall not be affected or impaired thereby.
10. The failure of either party to enforce any term or condition of this Agreement shall not constitute a waiver of either party's right to enforce each and every term and condition of this Agreement. No breach under this agreement shall be deemed waived or excused by either party unless such waiver or consent is in writing signed by the party granting such waiver or consent. The waiver by or consent of a party to a breach of any provision of this Agreement shall not operate or be construed as a waiver of or consent to any other or subsequent breach by such other party.
11. This Agreement may not be assigned (including by operation of law or otherwise) by you without WILEY's prior written consent.
12. Any fee required for this permission shall be non-refundable after thirty (30) days from receipt
13. These terms and conditions together with CCC's Billing and Payment terms and conditions (which are incorporated herein) form the entire agreement between you and WILEY concerning this licensing transaction and (in the absence of fraud) supersedes all prior agreements and representations of the parties, oral or written. This Agreement may not be amended except in writing signed by both parties. This Agreement shall be binding upon and inure to the benefit of the parties' successors, legal representatives, and authorized assigns.
14. In the event of any conflict between your obligations established by these terms and conditions and those established by CCC's Billing and Payment terms and conditions, these terms and conditions shall prevail.
15. WILEY expressly reserves all rights not specifically granted in the combination of (i) the license details provided by you and accepted in the course of this licensing transaction, (ii) these terms and

conditions and (iii) CCC's Billing and Payment terms and conditions.

16. This Agreement will be void if the Type of Use, Format, Circulation, or Requestor Type was misrepresented during the licensing process.

17. This Agreement shall be governed by and construed in accordance with the laws of the State of New York, USA, without regards to such state's conflict of law rules. Any legal action, suit or proceeding arising out of or relating to these Terms and Conditions or the breach thereof shall be instituted in a court of competent jurisdiction in New York County in the State of New York in the United States of America and each party hereby consents and submits to the personal jurisdiction of such court, waives any objection to venue in such court and consents to service of process by registered or certified mail, return receipt requested, at the last known address of such party.

Wiley Open Access Terms and Conditions

Wiley publishes Open Access articles in both its Wiley Open Access Journals program [<http://www.wileyopenaccess.com/view/index.html>] and as Online Open articles in its subscription journals. The majority of Wiley Open Access Journals have adopted the [Creative Commons Attribution License](#) (CC BY) which permits the unrestricted use, distribution, reproduction, adaptation and commercial exploitation of the article in any medium. No permission is required to use the article in this way provided that the article is properly cited and other license terms are observed. A small number of Wiley Open Access journals have retained the [Creative Commons Attribution Non Commercial License](#) (CC BY-NC), which permits use, distribution and reproduction in any medium, provided the original work is properly cited and is not used for commercial purposes.

Online Open articles - Authors selecting Online Open are, unless particular exceptions apply, offered a choice of Creative Commons licenses. They may therefore select from the CC BY, the CC BY-NC and the [Attribution-NoDerivatives](#) (CC BY-NC-ND). The CC BY-NC-ND is more restrictive than the CC BY-NC as it does not permit adaptations or modifications without rights holder consent.

Wiley Open Access articles are protected by copyright and are posted to repositories and websites in accordance with the terms of the applicable Creative Commons license referenced on the article. At the time of deposit, Wiley Open Access articles include all changes made during peer review, copyediting, and publishing. Repositories and websites that host the article are responsible for incorporating any publisher-supplied amendments or retractions issued subsequently. Wiley Open Access articles are also available without charge on Wiley's publishing platform, **Wiley Online Library** or any successor sites.

Conditions applicable to all Wiley Open Access articles:

- The authors' moral rights must not be compromised. These rights include the right of "paternity" (also known as "attribution" - the right for the author to be identified as such) and "integrity" (the right for the author not to have the work altered in such a way that the author's reputation or integrity may be damaged).
- Where content in the article is identified as belonging to a third party, it is the obligation of the user to ensure that any reuse complies with the copyright policies of the owner of that content.

- If article content is copied, downloaded or otherwise reused for research and other purposes as permitted, a link to the appropriate bibliographic citation (authors, journal, article title, volume, issue, page numbers, DOI and the link to the definitive published version on Wiley Online Library) should be maintained. Copyright notices and disclaimers must not be deleted.
 - Creative Commons licenses are copyright licenses and do not confer any other rights, including but not limited to trademark or patent rights.
- Any translations, for which a prior translation agreement with Wiley has not been agreed, must prominently display the statement: "This is an unofficial translation of an article that appeared in a Wiley publication. The publisher has not endorsed this translation."

Conditions applicable to non-commercial licenses (CC BY-NC and CC BY-NC-ND)

For non-commercial and non-promotional purposes individual non-commercial users may access, download, copy, display and redistribute to colleagues Wiley Open Access articles. In addition, articles adopting the CC BY-NC may be adapted, translated, and text- and data-mined subject to the conditions above.

Use by commercial "for-profit" organizations

Use of non-commercial Wiley Open Access articles for commercial, promotional, or marketing purposes requires further explicit permission from Wiley and will be subject to a fee. Commercial purposes include:

- Copying or downloading of articles, or linking to such articles for further redistribution, sale or licensing;
- Copying, downloading or posting by a site or service that incorporates advertising with such content;
- The inclusion or incorporation of article content in other works or services (other than normal quotations with an appropriate citation) that is then available for sale or licensing, for a fee (for example, a compilation produced for marketing purposes, inclusion in a sales pack)
- Use of article content (other than normal quotations with appropriate citation) by for-profit organizations for promotional purposes
- Linking to article content in e-mails redistributed for promotional, marketing or educational purposes;
- Use for the purposes of monetary reward by means of sale, resale, license, loan, transfer or other form of commercial exploitation such as marketing products
- Print reprints of Wiley Open Access articles can be purchased from:
corporatesales@wiley.com

The modification or adaptation for any purpose of an article referencing the CC BY-NC-ND License requires consent which can be requested from RightsLink@wiley.com.

Other Terms and Conditions:

BY CLICKING ON THE "I AGREE..." BOX, YOU ACKNOWLEDGE THAT YOU HAVE READ AND FULLY UNDERSTAND EACH OF THE SECTIONS OF AND PROVISIONS SET FORTH IN THIS AGREEMENT AND THAT YOU ARE IN AGREEMENT WITH AND ARE WILLING TO ACCEPT ALL OF YOUR OBLIGATIONS AS SET FORTH IN THIS AGREEMENT.

v1.8

If you would like to pay for this license now, please remit this license along with your payment made payable to "COPYRIGHT CLEARANCE CENTER" otherwise you will be invoiced within 48 hours of the license date. Payment should be in the form of a check or money order referencing your account number and this invoice number RLNK501248997. Once you receive your invoice for this order, you may pay your invoice by credit card. Please follow instructions provided at that time.

**Make Payment To:
Copyright Clearance Center
Dept 001
P.O. Box 843006
Boston, MA 02284-3006**

For suggestions or comments regarding this order, contact RightsLink Customer Support: customercare@copyright.com or +1-877-622-5543 (toll free in the US) or +1-978-646-2777.

Gratis licenses (referencing \$0 in the Total field) are free. Please retain this printable license for your reference. No payment is required.

ANNEX II

A

∞

∞

D

4

3

2

1

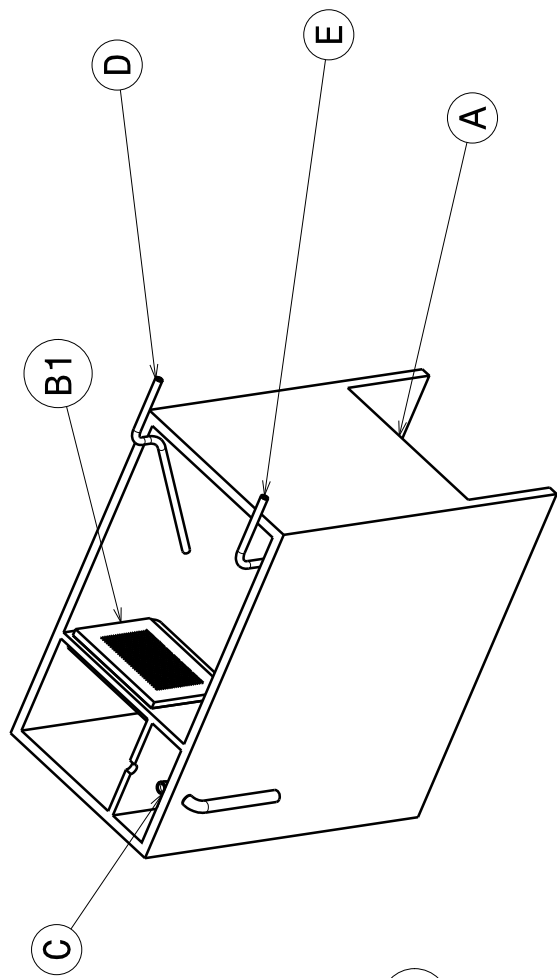

Nº	Name	Description
A	Aquarium	Pseudo-Kreisel Plexiglas Tank
B1	500 µm Mesh	
B2	250 µm Mesh	
C	Water Outflow	P.V.C. Tube with 16 mm ϕ
D	Air Pipe	Plastic Pipe with 6 mm ϕ
E	Water Inlet	P.V.C. Tube with 12 mm ϕ

This drawing is our property.
It can't be reproduced
or communicated without
our written agreement.

DRAWN BY	DATE
A. Lasen	XXX
CHECKED BY	DATE
A. Blanco	XXX
DESIGNED BY	DATE
M. Planas	XXX

DRAWING TITLE

Pseudo-Kreisel Tank

SIZE	DRAWING NUMBER	REV
A4	Number one	

SCALE 1:10

SHEET 1/3

A

D

4

3

2

1

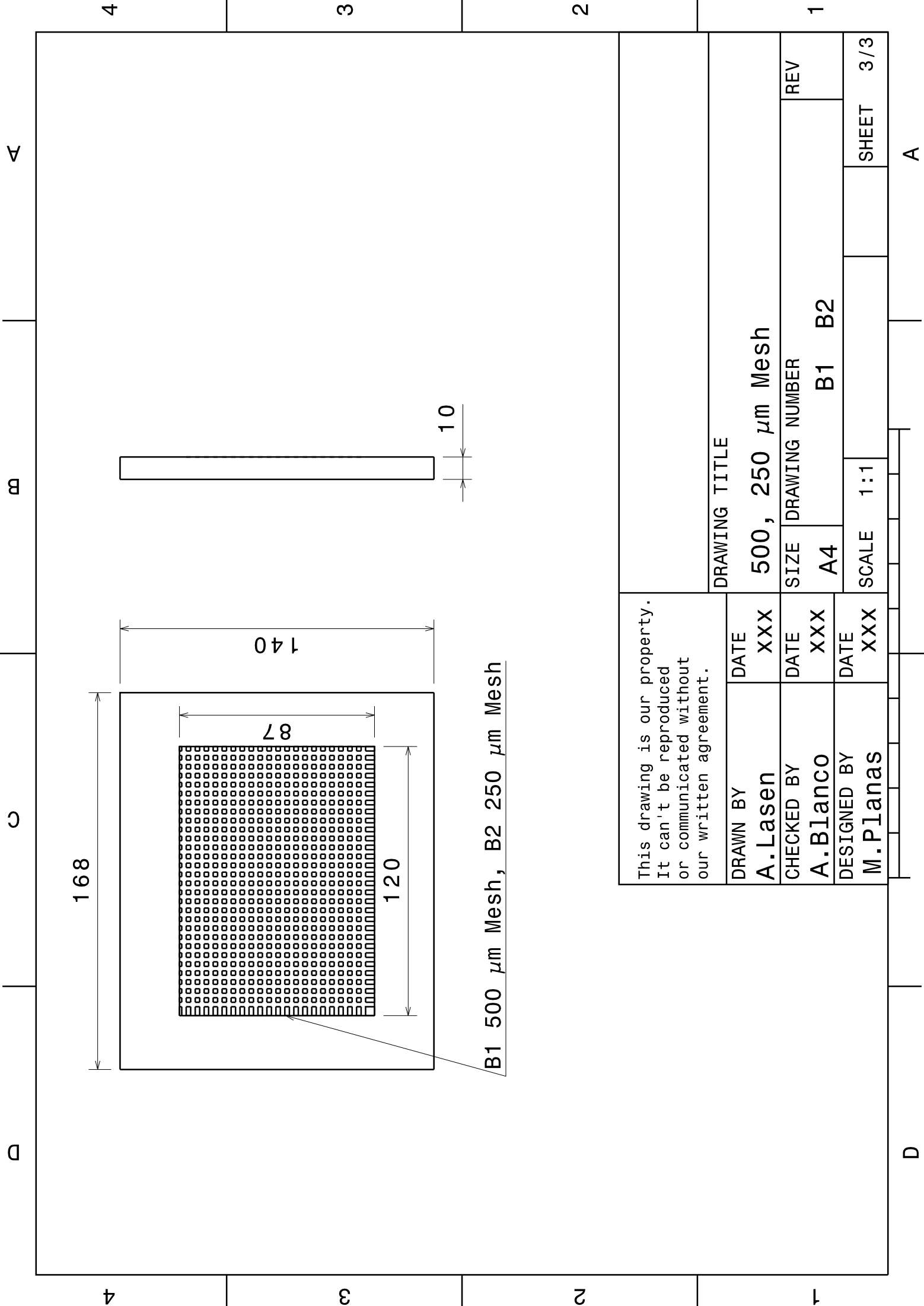

B1 500 μm Mesh, B2 250 μm Mesh

This drawing is our property.
It can't be reproduced
or communicated without
our written agreement.

DRAWN BY	DATE
A. Lasen	XXX
CHECKED BY	DATE
A. Bianco	XXX
DESIGNED BY	DATE
M. Planas	XXX

DRAWING TITLE

500, 250 μm Mesh

SIZE	DRAWING NUMBER	REV
A4	B1 B2	

SCALE	1:1	SHEET	3/3
-------	-----	-------	-----

A

B

C

D

4

3

2

1

A

D

4

3

2

1

4 3 2 1

∞

∞

D

A

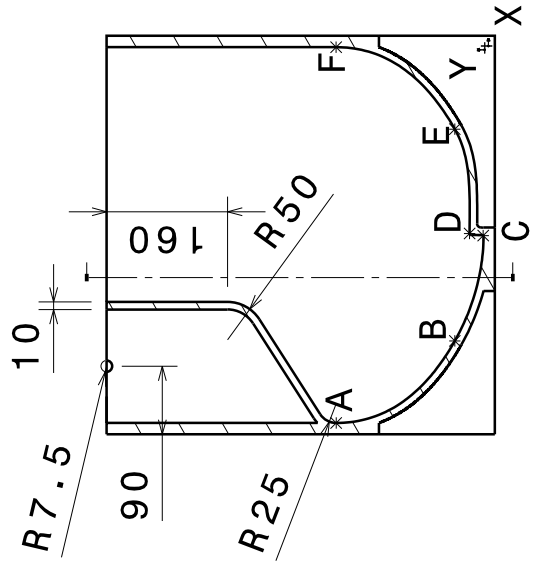
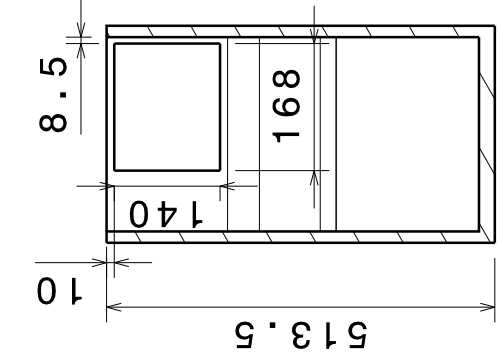

Coordinated points		
REF.	X	Y
A	-498,5	196,45
B	-390	39,5
C	-250,69	2
D	-248	20
E	-110	39,5
F	-1,5	196,5

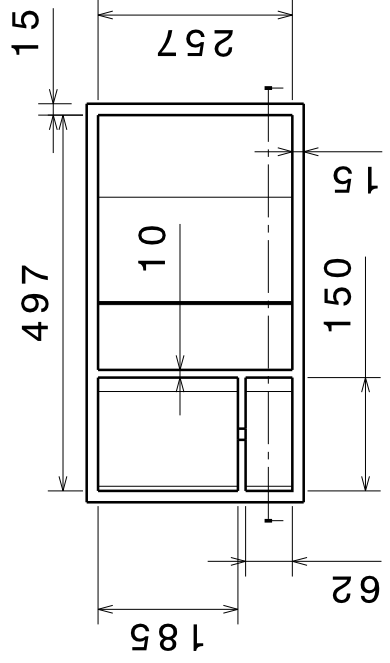

This drawing is our property.
It can't be reproduced
or communicated without
our written agreement.

DRAWN BY	DATE
A.Lasen	XXX
CHECKED BY	DATE
A.Blanco	XXX
DESIGNED BY	DATE
M.Planas	XXX

DRAWING TITLE	
Aquarium	
SIZE	DRAWING NUMBER
A4	A
SCALE 1:10	

REV	SHEET
1	2/3

D

A

D

C

B

A

4

4

3

3

2

2

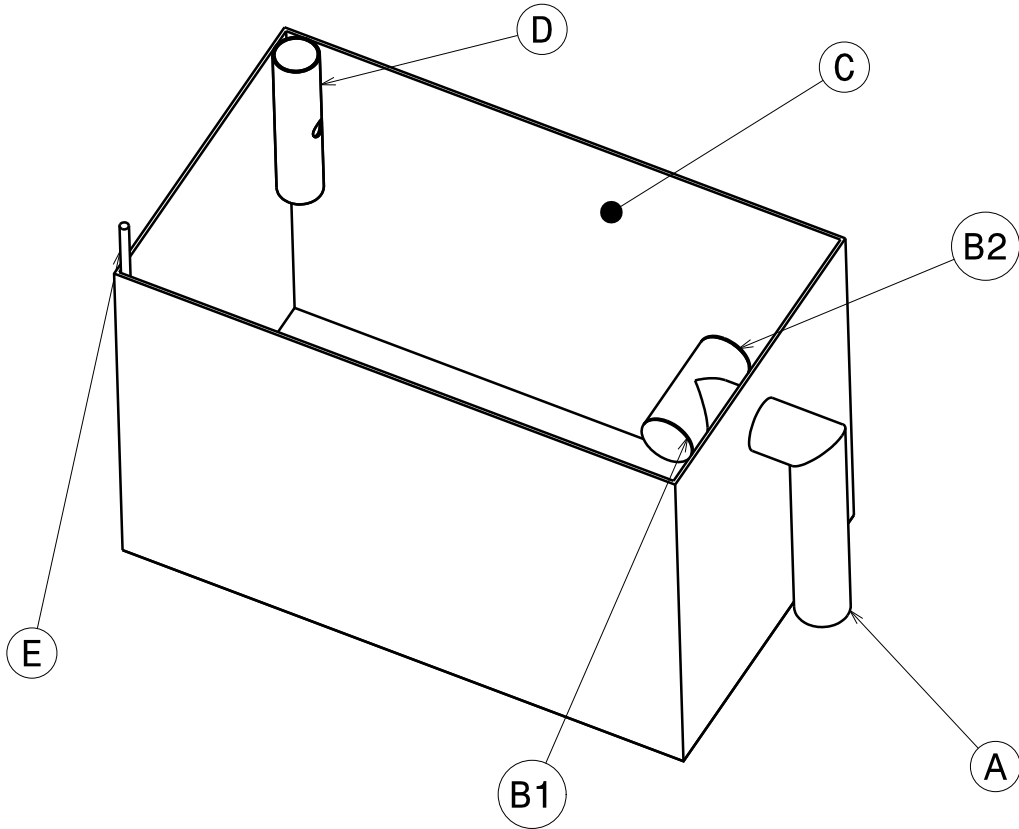

Nº	Name	Description
A	Water Outflow	P.V.C. Tube with 30 mm ϕ
B1	500 μ m Mesh	
B2	250 μ m Mesh	
C	Aquarium	335x195x200 mm Plexiglas tank
D	Water Inlet	P.V.C. Tube with 25 mm ϕ
E	Air Pipe	Glass Pipe with 5 mm ϕ

1

1

This drawing is our property.
It can't be reproduced
or communicated without
our written agreement.

DRAWING TITLE

DRAWN BY
A.LasenDATE
xxx

Rectangular Tank

CHECKED BY
A.BlancoDATE
xxxSIZE
A4DRAWING NUMBER
Number One

REV

DESIGNED BY
M.PlanasDATE
xxx

SCALE 1:4

SHEET 1/3

D

A

D

C

B

A

4

4

70

A

B

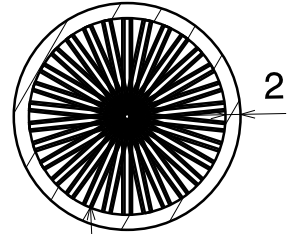
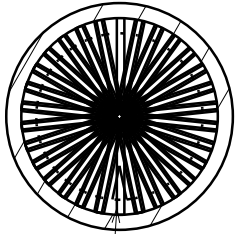

$\phi 30$

A

B

3

3

500 μm Mesh

250 μm Mesh

$\phi 30$

2

2

This drawing is our property.
 It can't be reproduced
 or communicated without
 our written agreement.

DRAWING TITLE

DRAWN BY
A.Lasen

DATE
XXX

Water Outflow

CHECKED BY
A.Blanco

DATE
XXX

SIZE
A4

DRAWING NUMBER
A B1 B2

REV

DESIGNED BY
M.Planas

DATE
XXX

SCALE 1:1

SHEET 3/3

D

A

1

1

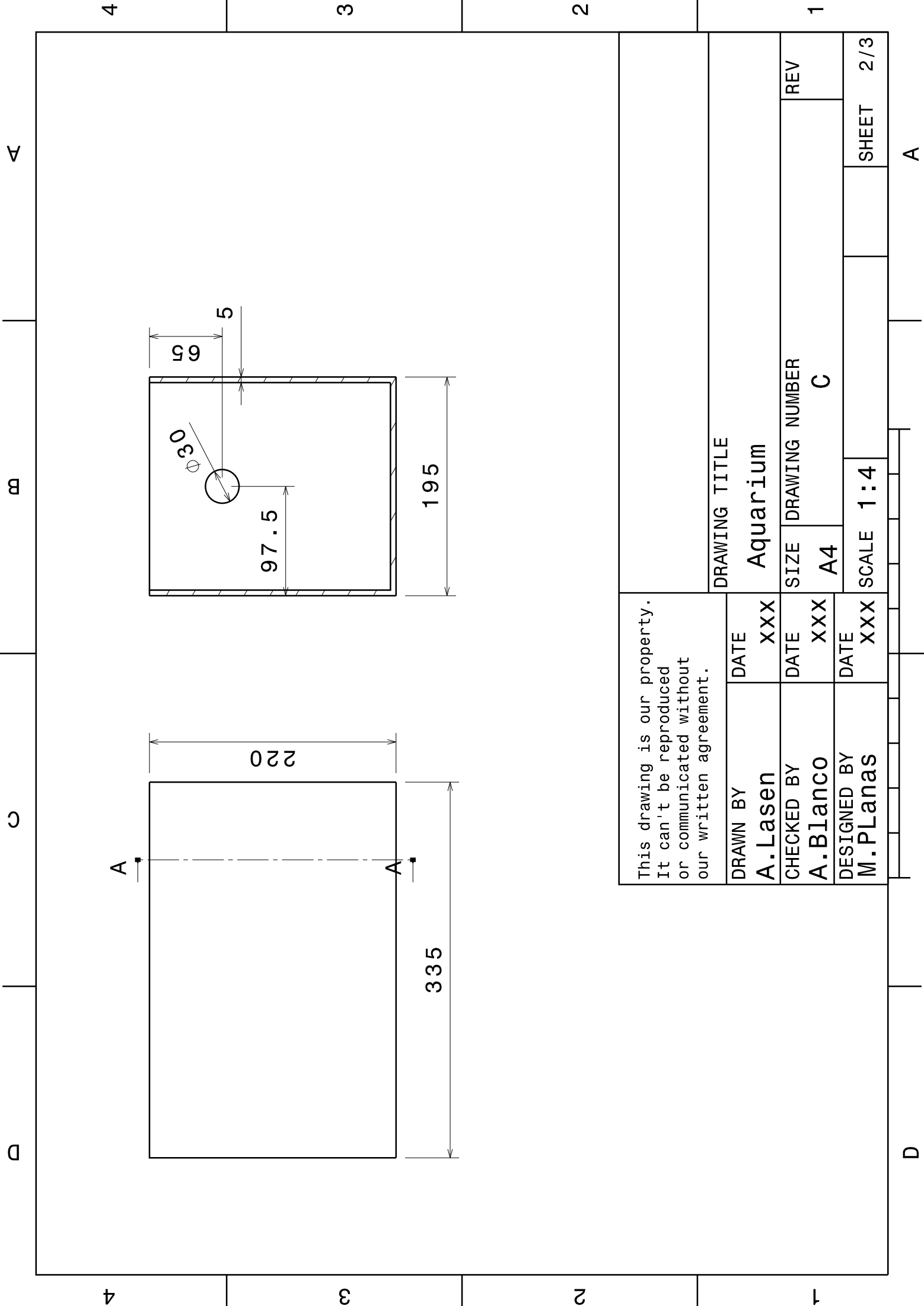

4

3

2

1

A

m

C

D

4

3

2

1

A

D

A

A

65

5

30

97.5

195

220

335

DRAWING TITLE

Aquarium

REV

SIZE DRAWING NUMBER

C

SHEET

2/3

SCALE

1:4

A

∞

∞

D

4

4

4

3

3

2

2

1

1

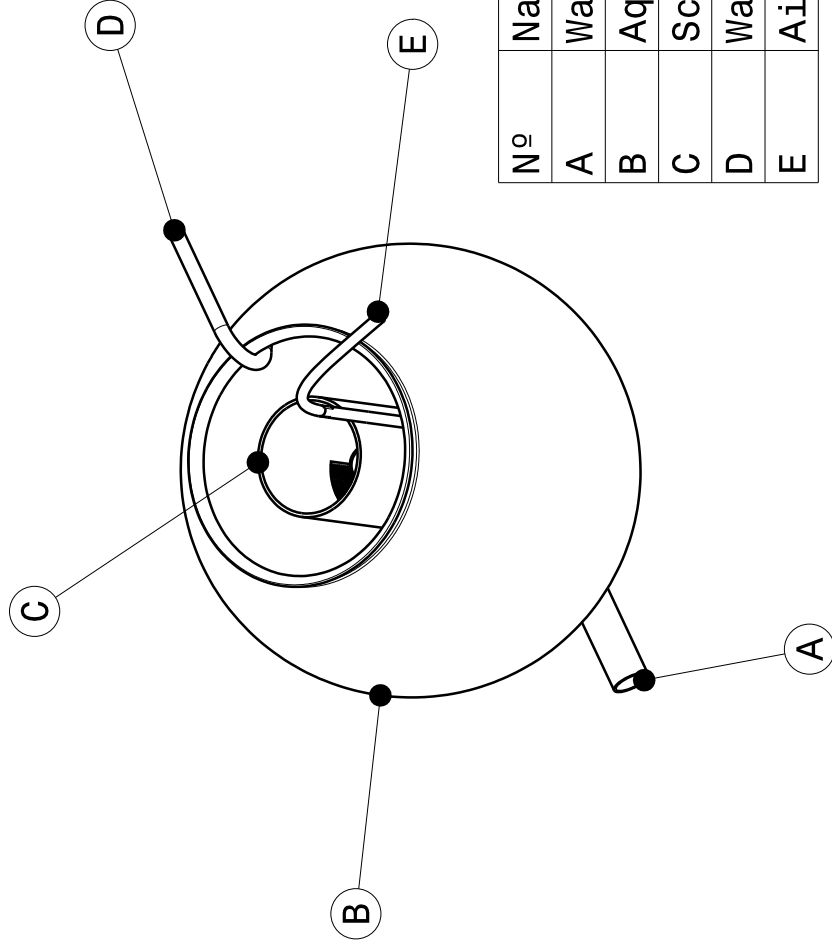

Nº	Name	Description
A	Water Outflow	P.V.C. Tube with 20 mm ϕ
B	Aquarium	
C	Screened Tube	P.V.C. Tube with a 500 μ m Mesh
D	Water Inlet	Plastic Tube with 8 mm ϕ
E	Air Pipe	Glass Pipe with 6 mm ϕ

This drawing is our property.
It can't be reproduced
or communicated without
our written agreement.

DRAWN BY	DATE
A.Lasen	XXX
CHECKED BY	DATE
A.Blanco	XXX
DESIGNED BY	DATE
M.Planas	XXX

DRAWING TITLE

Sphere Tank

SIZE DRAWING NUMBER REV

A4 Number One

SCALE 1:4

SHEET 1/3

D

A

D

C

B

A

4

4

3

3

2

2

1

1

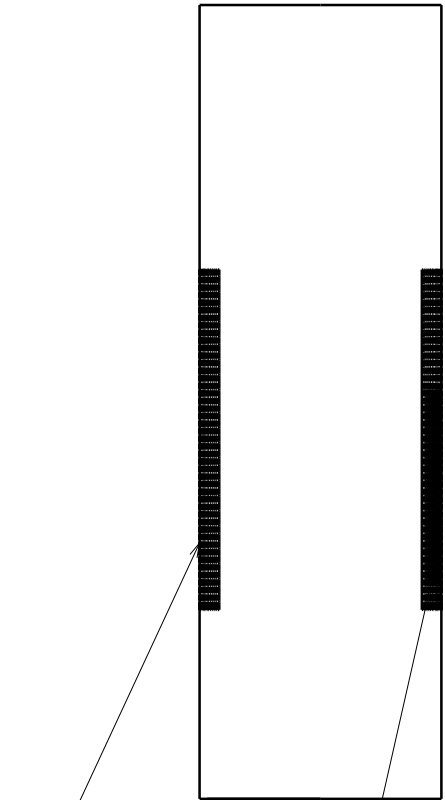
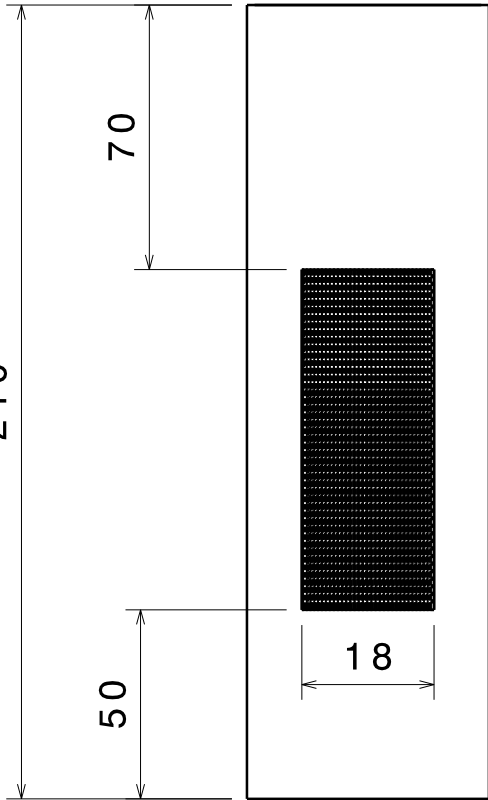

500 μm Mesh

500 μm Mesh

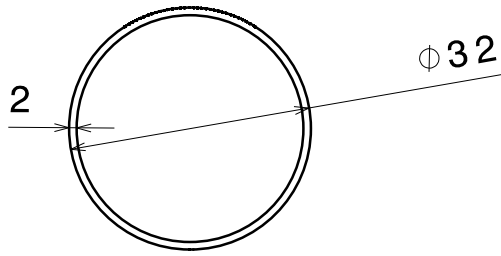

This drawing is our property.
 It can't be reproduced
 or communicated without
 our written agreement.

DRAWING TITLE

DRAWN BY
A.Lasen

DATE
XXX

Screened Tube

CHECKED BY
A.Blanco

DATE
XXX

SIZE
A4

DRAWING NUMBER
C

REV

DESIGNED BY
M.Planas

DATE
XXX

SCALE 1:2

SHEET 3/3

D

A

D

C

B

A

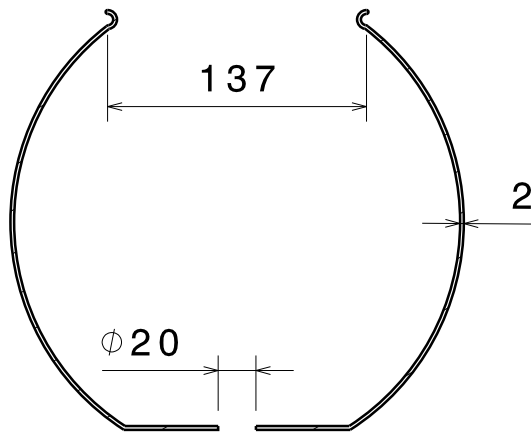
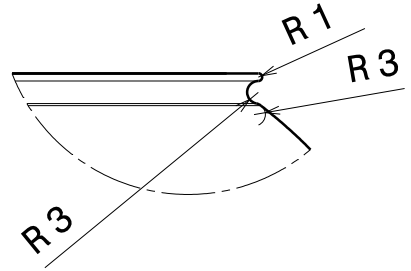
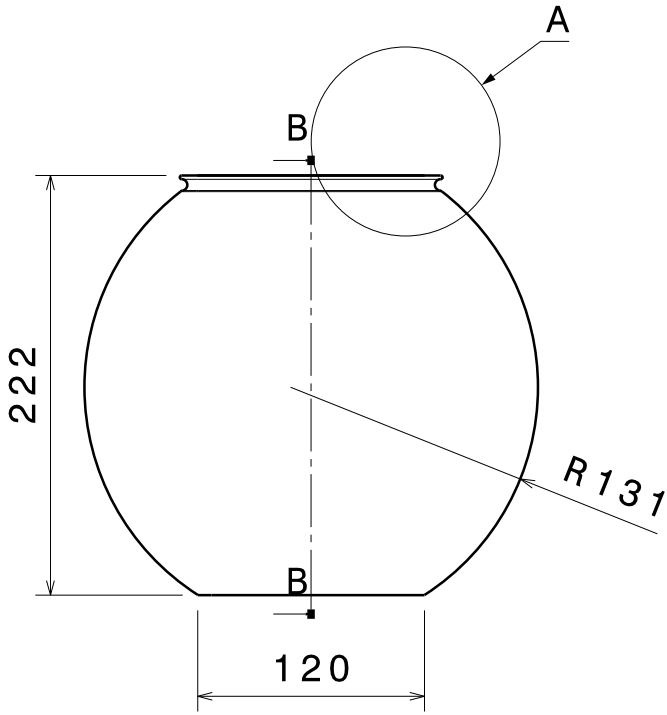

4

4

3

3

2

2

This drawing is our property.
It can't be reproduced
or communicated without
our written agreement.

DRAWING TITLE

Aquarium

DRAWN BY
A.Lasen

DATE
xxx

CHECKED BY
A.Blanco

DATE
xxx

DESIGNED BY
M.Planas

DATE
xxx

SIZE
A4

DRAWING NUMBER
B

REV

SCALE 1:4

SHEET 2/3

1

1

D

A

ANNEX III

EFFECT OF THE DIET IN ONGROWING AND MATURATION OF THE GRASS SHRIMP *PALAEMONETES VARIANS* (LEACH, 1814)

A. Blanco^{1*}, S. Valladares¹, R. Calado², M. Planas¹

¹ Instituto de Investigaciones Marinas (CSIC). Eduardo Cabello 6, 36208 Vigo (Spain)

² CESAM, Universidade de Aveiro, Dept. Biologia, Campus Universitário de Santiago, 3810-193 Aveiro, Portugal

E-mail: andreublanco@iim.csic.es

Introduction

The culture of the grass shrimp *Palaemonetes varians* for feeding purposes was not addressed until now. Information was almost lacking in this species, although partial information was provided by Yufera and Rodriguez (1985) and Calado et al. (2010;). This study provides useful information on ongrowing diets, female maturation and biochemical composition for the use of grass shrimp as live prey for cultured fishes.

Materials and methods

All specimens of *P. varians* were collected in natural ponds of Ria de Aveiro (Portugal), using small trawls nets. After two weeks of acclimation in the laboratory, a total of 240 shrimp were selected (between 18mm and 30mm total length) and maintained in captivity for 3 months under controlled conditions of salinity, temperature and water exchange (37‰, 23°C and 10 l h⁻¹, respectively), with moderate aeration and a photoperiod of 16L: 8O. Ongrowing was carried out in duplicate in 8 aquaria of 10L each (30 shrimps per aquarium). Grass shrimps were fed *ad libitum* twice daily on four different diets: a) food scales for tropical seafishes (Nutrafin max; 0,2g/day), b) *Artemia* metanauplii 24h (AF, Inve; 100.000 indiv/day), c) *Artemia* nauplii (AF, Inve; 100.000 indiv/day) and d) turbot dry food pellets (0,2g/day). Water exchange was stopped from 18:00h to 9:00h, to avoid depletion of food in the aquaria. Grass shrimps were weighed and measured for total length monthly and sex maturation of females were recorded daily. The proximate biochemical composition of diets and shrimps muscle (third month) was analysed.

Results

The relationship between total length (*L*; mm) and wet weight (*W*; mg) in *P. varians* was showed in Figure 1. Differences in weight gain were recorded among the four diets tested (Fig 2). Growth was improved with the addition of *Artemia*, specially enriched metanauplii. Similarly, *Artemia* also provided the highest rate of ovigerous females in *P. varians* fed with nauplii (26,3 ± 1,5%) and metanauplii (23,7 ± 7,3%) and lower rates for the ones fed with dry pellet (7,0 ± 4,0%) and dry scales (3,0 ± 1,0%). Final survival rate was specially high in shrimps fed on *Artemia* metanauplii (63,3 ± 0%) and on dry pellets (60,0 ± 4,7%), and lower in shrimps fed on food scales (53,3 ± 9,4%) and *Artemia* nauplii (50,0 ± 18,9%). The biochemical composition in *P. varians* (muscle) was characterised by a high level in total protein (Table I), with differences among treatments. Interestingly, glycogen contributed largely to total carbohydrates content in wild individuals, but much lower levels were obtained in shrimps maintained in captivity.

Discussion

Growth and female maturation in grass shrimps was enhanced by the use of live food (*Artemia* nauplii or metanauplii). However, the survival rate of shrimps was lowest in nauplii treatments and highest in shrimps fed on *Artemia* metanauplii. Feeding with *Artemia* nauplii provided biochemical profiles similar to that of wild shrimps. The use of glycogen content as nutritional indicator in *P. varians* must be considered. Overall, *Artemia* metanauplii was considered the best diet in the ongrowing of *Palaemonetes varians*, though a mixed diet of nauplii and metanauplii would provide higher protein levels.

Acknowledgements

The study was financed by the Spanish Government (Plan Nacional, CGL2009-08386) and Xunta de Galicia (09MDS022402PR). A. Blanco and S. Valladares were supported by a CSIC grant (JAE-CSIC contract).

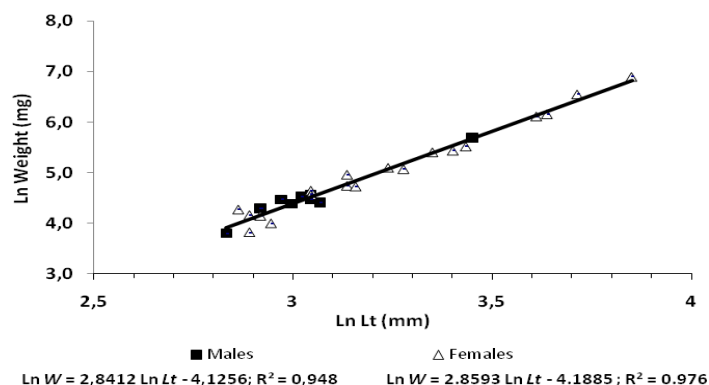

Fig. 1. Wet weight (W) – total length (Lt) relationship in Ln transformed data from grass shrimp *P. varians*.

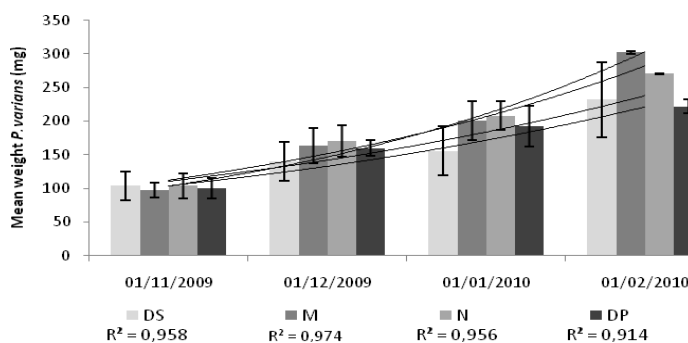

Fig. 2. Growth in wet weight (g) in the grass shrimp *P. varians* during the experimental period (3 months). DS = food scales for tropical seafishes; M = *Artemia* enriched metanauplii 24h of; N = *Artemia* nauplii ; and DP = dry pellet for turbot.

Percentage (%)	<i>P. varians</i> Wild individuals	<i>P. varians</i> Dry Scales	<i>P. varians</i> Dry Pellet	<i>P. varians</i> Nauplii	<i>P. varians</i> Metanauplii
PROTEIN	48,05 ± 1,60	50,13 ± 0,50	43,99 ± 2,14	48,75 ± 0,81	41,12 ± 1,10
CARBOHYDRATES	6,16 ± 0,32	4,31 ± 0,34	3,33 ± 0,05	5,13 ± 0,40	3,92 ± 1,26
GLYCOGEN	1,86 ± 0,07	0,56 ± 0,12	0,40 ± 0,03	0,66 ± 0,02	0,43 ± 0,10
LIPIDS	9,41 ± 1,04	9,12 ± 0,14	9,69 ± 0,14	9,49 ± 0,28	9,21 ± 0,28

Table 1. Biochemical composition (dry weight %) of grass shrimps *Palaemonetes varians* collected in natural ponds (wild individuals) and those fed on experimental diets (dry scales, dry pellets, *Artemia* nauplii and *Artemia* metanauplii) (mean ± SD)

References

- Calado, R., T. Pimentel, P. Pochelon, A. Olaguer-Feliú and H. Queiroga, 2010. Effect of food deprivation in late larval development and early benthic life of temperate marine coastal and estuarine caridean shrimp. *Journal of experimental marine Biology and Ecology* 384: 107-112
- Yufero M. and A. Rodriguez. 1985. Tasas de crecimiento y desarrollo de *Palaemonetes varians* (Crustacea: Palaemonidae) durante el desarrollo larvario. *Investigación Pesquera* 49:597-606

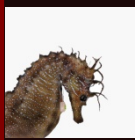

EFFECT OF THE DIET IN ONGROWING AND MATURATION OF THE GRASS SHRIMP *PALAEMONETES VARIANS* (LEACH, 1814)

A. Blanco, S. Valladares, R. Calado, M. Planas

Instituto de Investigaciones Marinas (CSIC), Eduardo Cabello 6, 36208 Vigo, Spain, +34 986214457
andreublanco@iim.csic.es



INTRODUCTION

The culture of the grass shrimp *Palaemonetes varians* for feeding purposes was not addressed until now. Information was almost lacking in this species, although partial information was provided by Yúfera and Rodríguez (1985) and Calado et al. (2010). This study provides useful information on ongrowing diets, female maturation and biochemical composition for the use of grass shrimp as live prey for cultured fishes.

MATERIALS AND METHODS

All specimens of *P. varians* were collected in natural ponds of Ria de Aveiro (Portugal), using small trawls nets. After two weeks of acclimation in the laboratory, a total of 240 shrimp were selected (between 18mm and 30mm total length) and maintained in captivity for 3 months under controlled conditions of salinity, temperature and water exchange (37‰, 23°C and 10 l h⁻¹, respectively), with moderate aeration and a photoperiod of 16L:8D, water exchange was stopped from 18:00h to 9:00h. Ongrowing was carried out in duplicate in 8 aquaria of 10L each (30 shrimps per aquaria). Grass shrimps were fed *ad libitum* twice daily on four different diets:

- food scales for tropical seafishes (Nutrafin max; 0,2g/day)
- Artemia* metanauplii 24h (AF, Inve; 100.000 indiv/day)
- Artemia* nauplii (AF, Inve; 100.000 indiv/day)
- turbot dry food pellets (0,2g/day)

Grass shrimps were weighed and measured for total length monthly and sex maturation of females were recorded daily.

The proximate biochemical composition of diets and shrimps muscle (third month) was analysed.

RESULTS AND DISCUSSION

The relationship between total length (L; mm) and wet weight (W; mg) in *P. varians* was showed in Figure 1. Differences in weight gain were recorded among the four diets tested (Fig 2). Growth was improved with the addition of *Artemia*, specially enriched metanauplii. Similarly, *Artemia* also provided the highest rate of ovigerous females in *P. varians* fed with nauplii (26,3 ± 1,5%) and metanauplii (23,7 ± 7,3%) and lower rates for the ones fed with dry pellet (7,0 ± 4,0%) and dry scales (3,0 ± 1,0%). Final survival rate was specially high in shrimps fed on *Artemia* metanauplii (63,3 ± 0%) and on dry pellets (60,0 ± 4,7%), and lower in shrimps fed on food scales (53,3 ± 9,4%) and *Artemia* nauplii (50,0 ± 18,9%). The biochemical composition in *P. varians* (muscle) was characterized by a high level in total protein (Table 1), with differences among treatments. Interestingly, glycogen contributed largely to total carbohydrates content in wild individuals, but much lower levels were obtained in shrimps maintained in captivity.

Growth and female maturation in grass shrimps was enhanced by the use of live food (*Artemia* nauplii or metanauplii). However, the survival rate of shrimps was lowest in nauplii treatments and highest in shrimps fed on *Artemia* metanauplii. Feeding with *Artemia* nauplii provided biochemical profiles similar to that of wild shrimps. The use of glycogen content as nutritional indicator in *P. varians* must be considered. Overall, *Artemia* metanauplii was considered the best diet in the ongrowing

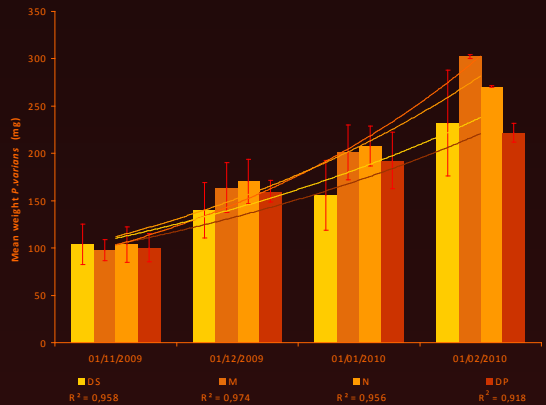

Fig. 1. Wet weight(W) – total length (Lt) relationship in Ln transformed data from grass shrimp *P. varians*.

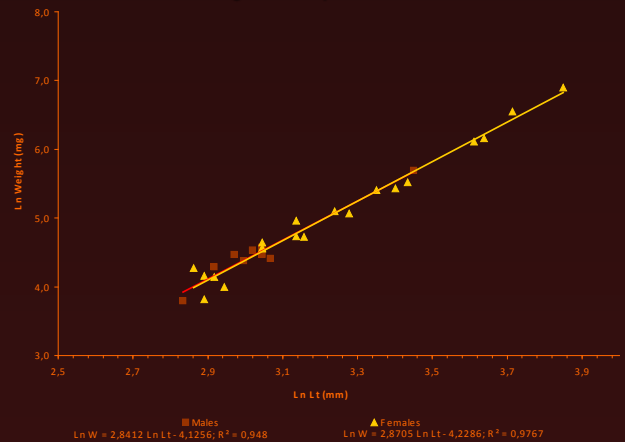

Fig. 2. Growth in wet weight (g) in the grass shrimp *P. varians* during the experimental period (3 months). DS = food scales for tropical seafishes; M = *Artemia* enriched metanauplii 24h of; N = *Artemia* nauplii ; and DP = dry pellet for turbot.

Table 1. Biochemical composition (dry weight %) of grass shrimps *Palaemonetes varians* collected in natural ponds (wild individuals) and those fed on experimental diets (dry scales, dry pellets, *Artemia* nauplii and *Artemia* metanauplii) (mean ± SD)

Food source	Natural Ponds	Dry scales	Dry pellet	<i>Artemia</i> nauplii	<i>Artemia</i> metanauplii
PROTEIN	48,05 ± 1,60	50,13 ± 0,50	43,99 ± 2,14	48,75 ± 0,81	41,12 ± 1,10
CARBOHYDRATES	6,16 ± 0,32	4,31 ± 0,34	3,33 ± 0,05	5,13 ± 0,40	3,92 ± 1,26
GLYCOGEN	1,86 ± 0,07	0,56 ± 0,12	0,40 ± 0,03	0,66 ± 0,02	0,43 ± 0,10
LIPIDS	9,41 ± 1,04	9,12 ± 0,14	9,69 ± 0,14	9,49 ± 0,28	9,21 ± 0,28

ACKNOWLEDGEMENTS

The study was financed by the Spanish Government (Plan Nacional, GGL2009-08386) and Xunta de Galicia (09MDS022402PR). A. Blanco and S. Valladares were supported by a CSIC grant (JAE-CSIC contract).

REFERENCES

- Calado, R., T. Pimentel, P. Pochelon, A. Olague-Feliú and H. Queiroga, 2010. Effect of food deprivation in late larval development and early benthic life of temperate marine coastal and estuarine caridean shrimp. *Journal of experimental marine Biology and Ecology* 384: 107-112
- Yúfera M. and A. Rodríguez. 1985. Tasas de crecimiento y desarrollo de *Palaemonetes varians* (Crustacea: Palaemonidae) durante el desarrollo larvario. *Investigación Pesquera* 49:597-606

ANNEX IV

PROXIMATE BIOCHEMICAL COMPOSITION AND ENZYMATIC ACTIVITIES IN EGGS OF FARMED SEAHORSES *Hippocampus guttulatus* AND *H. hippocampus* (PROJECT HIPPOCAMPUS)

J.P. Alvarez*, A. Blanco , C. Silva, M. Planas

Instituto de Investigaciones Marinas (CSIC)
Eduardo Cabello 6, 36208 Vigo (Spain)
E-mail: mplanas@iim.csic.es

Introduction

Biochemical composition and enzymatic activities in eggs provide essential information on early nutritional requirements of fry for rearing purposes. Until now, information was lacking for seahorse eggs, except for fatty acids (Planas, 2008). This study provides the first preliminary results obtained in eggs of European seahorses (*Hippocampus guttulatus* and *H. hippocampus*) maintained under culture conditions.

Materials and methods

Seahorses were maintained in captivity for two years. Information on maintenance conditions of seahorses is provided by Planas et al. (2008). Seahorses were fed *ad libitum* twice daily on enriched adult *Artemia* (EG, Inve), previously long-term enriched with Red Pepper (Bernaqua). Eggs dropped by females were analysed for proximate biochemical composition and enzymatic activities (Apizym Kits, Planas et al., 1989).

Results and discussion

High enzymatic activity in eggs was recorded for alkaline phosphatase, acid phosphatase, naphthol-AS-BI-phosphohydrolase, β -galactosidase and α -fucosidase, particularly in long-snouted seahorse eggs (Fig 1). These enzymes are mainly involved in mobilization of energetic sources in eggs, and most of them were already detected in turbot eggs (Planas et al., 1989). Compared to turbot eggs, major differences were related to the degradation of carbohydrates.

Biochemical composition in eggs was characterised specially by a very high level in lipids (Table I) which is related the high amount of oil droplets, but probably to the high lipid content in enriched adult *Artemia* (26-27% DW) offered to seahorses. Glycogen contributed largely to total carbohydrates content.

Conclusions

Seahorse eggs were mainly characterised by a high content in total lipids. The analysis of eggs from wild females would contribute to understand the origin (food or species dependent) of such a high lipid level and to explain differences among both seahorse species for some enzymatic activities, but also with eggs of other marine fish.

Acknowledgements

The study was financed by the Spanish Government (Plan Nacional, CGL2005-05927-C03-01) and Xunta de Galicia (PGIDIT06PXIC402106PN). J.P. Álvarez (UMET Puerto Rico), A. Blanco and C. Silva (Univ. Aveiro, Portugal) were supported by a CSIC grant, a JAE-CSIC contract and an UE-Erasmus grant, respectively. Adults of *H. hippocampus* were supplied by ICCM (Telde, Canary Islands).

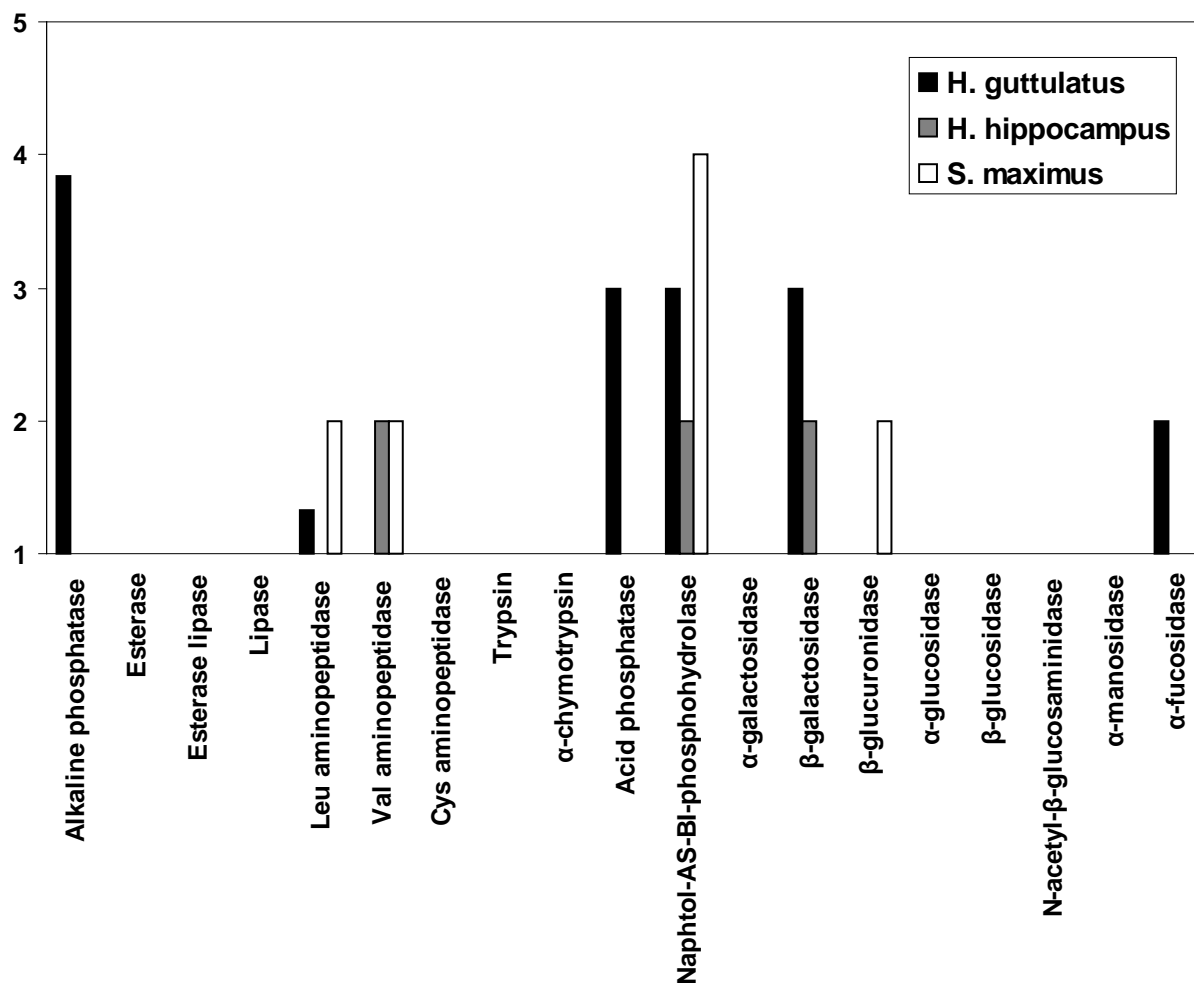

Fig. 1. Enzymatic activities in seahorse (*H. guttulatus* and *H. hippocampus*) and turbot eggs. Only values above 1 are provided. Score 5 means maximal activity. Data for turbot from Planas et al. (1989).

	<i>H. guttulatus</i> (n=6)	<i>H. hippocampus</i> (n=2)
Protein	56.2 ± 5.0	53.3 ± 2.6
Lipids	35.8 ± 1.1	37.7 ± 4.6
Carbohydrates	2.2 ± 0.4	2.48 ± 0.2
Glycogen	1.7 ± 0.3	2.05 ± 0.3

Table I - Biochemical composition (DW %) of eggs (*H. guttulatus* and *H. hippocampus*) (mean±sd)

References

- Planas, M., A. Chamorro, P. Quintas and A. Vilar 2008. Establishment and maintenance of threatened long-snouted seahorse, *Hippocampus guttulatus*, broodstock in captivity. *Aquaculture*, 283: 18-28.
- Planas, M., M.J. Ferreiro, M.J. Fernández-Reiríz and U. Labarta. 1989. Evolución de la composición bioquímica y actividades enzimáticas en huevos de rodaballo (*Scophthalmus maximus* L.) durante la embriogénesis. In: *Acuicultura Intermareal*, M. Yúfera (Ed). Inst. Cien. Mar. Andalucía, Cádiz., 215-227.

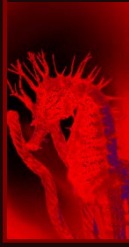

PROXIMATE BIOCHEMICAL COMPOSITION AND ENZYMATIC ACTIVITIES IN EGGS OF FARMED SEAHORSES *Hippocampus guttulatus* AND *H. hippocampus* (PROJECT HIPPOCAMPUS)

J.P. Álvarez, A. Blanco, C. Silva, M. Planas

Instituto de Investigaciones Marinas (CSIC), Eduardo Cabello 6, 36208 Vigo, Spain, +34 986214457
mplanas@iim.csic.es



INTRODUCTION

Biochemical composition and enzymatic activities in eggs provide essential information on early nutritional requirements of fry for rearing purposes. Until now, information was lacking for seahorse eggs, except for fatty acids (Planas, 2008). This study provides the first preliminary results obtained in eggs of European seahorses (*Hippocampus guttulatus* and *H. hippocampus*) maintained under culture conditions.

MATERIALS AND METHODS

Seahorses were maintained in captivity for two years. Information on maintenance conditions of seahorses is provided by Planas et al. (2008). Seahorses were fed *ad libitum* twice daily on enriched adult Artemia (EG, Inve), previously long-term enriched with Red Pepper (Bernaqua). Eggs dropped by females were analysed for proximate biochemical composition and enzymatic activities (Apizym Kits, Planas et al., 1989).

RESULTS AND DISCUSSION

High enzymatic activity in eggs was recorded for alkaline phosphatase, acid phosphatase, naphthol-AS-BI-phosphohydrolase, β -galactosidase and α -fucosidase, particularly in long-snouted seahorse eggs (Fig 1). These enzymes are mainly involved in mobilization of energetic sources in eggs, and most of them were already detected in turbot eggs (Planas et al., 1989). Compared to turbot eggs, major differences were related to the degradation of carbohydrates.

Biochemical composition in eggs was characterized specially by a very high level in lipids (Fig 2) which is related the high amount of oil droplets, but probably to the high lipid content in enriched adult Artemia (26-27% DW) offered to seahorses. Glycogen contributed largely to total carbohydrates content.

CONCLUSIONS

Seahorse eggs were mainly characterized by a high content in total lipids. The analysis of eggs from wild females would contribute to understand the origin (food or species dependent) of such a high lipid level and to explain differences among both seahorse species for some enzymatic activities, but also with eggs of other marine fish.

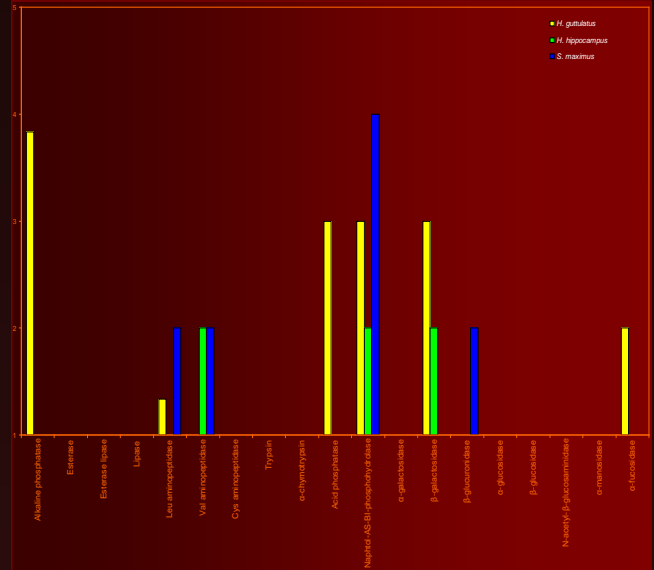

Fig. 1. Weight (gr) of seahorses (males and females) maintained in captivity for two seasons.

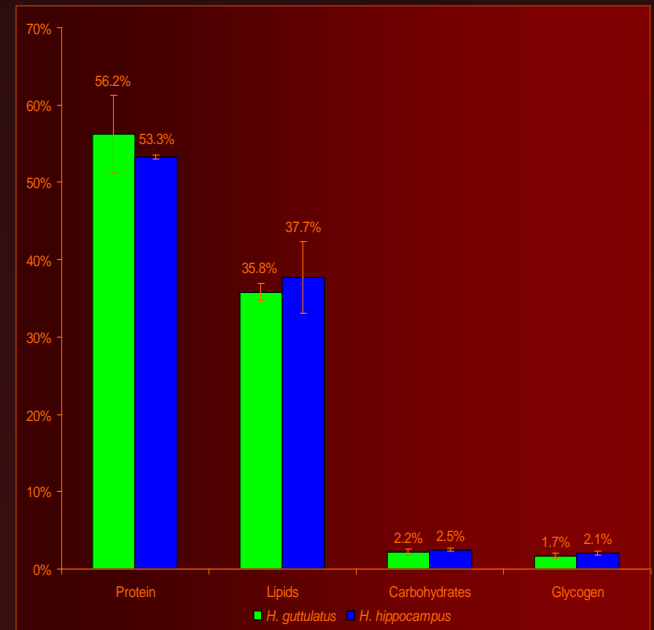

Fig 2. Biochemical composition (DW %) of eggs (*H. guttulatus* and *H. hippocampus*) (mean)

ACKNOWLEDGEMENTS

The study was financed by the Spanish Government (Plan Nacional, CGL2005-05927-C03-01) and Xunta de Galicia (PGIDIT06PXIC402106PN). J.P. Álvarez (UMET Puerto Rico), A. Blanco and C. Silva (Univ. Aveiro, Portugal) were supported by a CSIC grant, a JAE-CSIC contract and an UE-Erasmus grant, respectively. Adults of *H. hippocampus* were supplied by ICCM (Telde, Canary Islands).

REFERENCES

- Planas, M., A. Chamorro, P. Quintas and A. Vilar 2008. Establishment and maintenance of threatened long-snouted seahorse, *Hippocampus guttulatus*, broodstock in captivity. *Aquaculture*, 283: 18-28.
- Planas, M., M.J. Ferreiro, M.J. Fernández-Reiriz and U. Labarta. 1989. Evolución de la composición bioquímica y actividades enzimáticas en huevos de rodaballo (*Scophthalmus maximus* L.) durante la embriogénesis. In: *Acuicultura Intermareal*, M. Yúfera (Ed). Inst. Cien. Mar. Andalucía, Cádiz, 215-227.

ANNEX V

CATABOLIC SOURCES IN THE EARLY DEVELOPMENT OF LONG-SNOUDED SEAHORSE *HIPPOCAMPUS GUTTULATUS* UNDER STARVING CONDITIONS

Blanco A., Quintas P. and Planas M.

Instituto de Investigaciones Marinas (CSIC), Eduardo Cabello 6, 36208 Vigo, Spain, +34 986214457 andreublanco@iim.csic.es

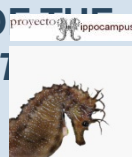

110 ©Marcel Serrão, 2008

INTRODUCTION

The main bottleneck on seahorse culture is the low survivals during the first days of life (Olivotto 2008, Planas 2009). It is very like due to low feeding efficiency and low digestion capabilities (Planas 2006). Knowledge on biochemical changes occurring during the early development is useful for determining appropriate diets in early rearing. Changes in the biochemical composition can be used as indicator of the nutritional status of marine animals (Olsen 1998). Nutritional requirements in early developmental stages of seahorses are unknown. The long-snouted seahorse has still remaining unknown several issues such as nutritional requirements during early-stages. In the present study, we investigated changes in the proximate biochemical composition (protein, total lipids, carbohydrates and glycogen) of newborn *Hippocampus guttulatus* Cuvier 1829 in order to ascertain the main energy sources under starving conditions until death.

MATERIALS AND METHODS

Two pregnant adult seahorses (*H. guttulatus*) were collected at Sada Harbour in Galicia (NW Spain) in May 2010. Temperature and natural-like light regimes were applied. Animals were fed ad libitum twice daily on live enriched adult *Artemia* (EG Artemia, Inve, Spain) and mysis as a supplement. Both males released two batches of completely well-developed newborns composed by 450 (Batch 1) and 468 (Batch 2) seahorses.

Newborns were transferred to 30L aquaria and submitted to 16L:8D photoperiod, a temperature of 20 ± 1°C and an incoming seawater flux of 450ml/min.

Samples (n<80) of newborns were taken at days 0, 1, 3 and 6 and submitted to biochemical analyses (Planas et al., 1989).

	Day 0	Day 1	Day 3	Day 6
Dry weight (µg)	870,56 ± 44,81	748,44 ± 146,99	700,50 ± 153,62	660,12 ± 151,44
Proteins (µg/newborn)	347.38 ± 65.82	312.40 ± 3.61	253.70 ± 41.39	212.76 ± 32.94
Lipids (µg/newborn)	133.75 ± 10.09	94.26 ± 6.86	95.77 ± 34.81	97.61 ± 33.76
Carbohydrates (µg/newborn)	24.20 ± 0.00	15.04 ± 1.30	14.98 ± 2.05	12.78 ± 0.02
Glycogen (µg/newborn)	11.29 ± 2.84	8.87 ± 0.25	7.94 ± 2.22	7.61 ± 2.06
Ash (µg/newborn)	76.67 ± 1.39	83.21 ± 23.31	80.77 ± 16.95	77.48 ± 1.35

Table 1. Biochemical composition of newborn seahorses *H. guttulatus*. Days 0, 1, 3 and 6.

	Global change				Change per day			
	Day 0-1	Day 1-3	Day 3-6	Day 0-6	Day 0-1	Day 1-3	Day 3-6	Day 0-6
Protein (J/µg)	-0,61	-1,03	-0,71	-2,36	-0,61	-0,515	-0,236	-0,393
Lipid (J/µg)	-1,56	0,06	0,07	-1,43	-1,56	0,03	0,023	-0,476
Carbohydrate (J/µg)	-0,22	0,00	-0,05	-0,27	-0,22	0,00	-0,016	-0,045
Total energy (J/µg)	-2,39	-0,97	-0,69	-4,06	-2,39	-0,485	-0,23	-0,676

Table 2. Global energy change and energy change per day of newborns *H. guttulatus* for the sampled intervals between days 0, 1, 3 and 6.

RESULTS AND DISCUSSION

The most important changes occurred during the first 24 h after birth (table 1). During this period, a 14% loss in dry weight was accompanied by a drop in protein and mainly in total lipids. About 60% of the total energy consumed until day 6 was catabolised during the first day (table 2). From day 1 to 3, protein was almost the unique fuel source, as lipids were almost depleted during the first 24 h. Similarly, the almost unique catabolic source from day 3 to 6, before death by starvation, was protein.

In conclusion, the first 24 hours of life were energetically critical in the development of newborn *H. guttulatus*, with a high requirement in both protein and lipids. Access to prey in newborns of *H. guttulatus* should be guaranteed as soon as possible in order to avoid excessive energy expenditure.

ACKNOWLEDGEMENTS: The study was financed by the Spanish Government (CGL2009-08386) and the Regional Government Xunta de Galicia (09MDS022402PR). Patricia Quintas was supported by a postdoctoral contract and a grant (JAE Doc-CSIC). A. Blanco is supported by a JAE Pre Grant-CSIC. Thanks to A. Chamorro, T. Hermelo and S. Valladares for their assistance in the maintenance of the cultures.

REFERENCES

- Olivotto, I., Avella, M.A., Sampaolese, G., Piccinetti, C.C., Navarro-Ruiz, P., Carnevali, O., 2008. Breeding and rearing the longsnout seahorse *Hippocampus reidi*: Rearing and feeding studies. *Aquaculture* 283, 92–96
- Planas, M., Chamorro, A., Quintas, P., Vilar, A., 2008. Establishment and maintenance of threatened long-snouted seahorse, *Hippocampus guttulatus*, broodstock in captivity. *Aquaculture* 283: 19-28
- Planas, M., Quintas, P., Chamorro, A., Balcazar, J.L., 2009. Husbandry and rearing of the seahorse *Hippocampus guttulatus* (Project Hippocampus). *World Aquaculture Society: Veracruz (México)*
- Planas, M., M.J. Ferreiro, M.J. Fernández-Reiriz and U. Labarta. 1989. Evolución de la composición bioquímica y actividades enzimáticas en huevos de rodaballo (*Scophthalmus maximus* L.) durante la embriogénesis. In: *Acuicultura Intermareal*, M. Yúfera (Ed). Inst. Cien. Mar. Andalucía, Cádiz., 215-227.

