

Assimilació, resistència i canvi a la romanització en el món ilerget

(Aproximació a l'Horitzó Ibèric Tardà i les seves pervivències a les comarques de plana de les províncies d'Osca i Lleida)

Ignasi Garcés i Estalló

ADVERTIMENT. La consulta d'aquesta tesi queda condicionada a l'acceptació de les següents condicions d'ús: La difusió d'aquesta tesi per mitjà del servei TDX (www.tesisenxarxa.net) ha estat autoritzada pels titulars dels drets de propietat intel·lectual únicament per a usos privats emmarcats en activitats d'investigació i docència. No s'autoritza la seva reproducció amb finalitats de lucre ni la seva difusió i posada a disposició des d'un lloc aliè al servei TDX. No s'autoritza la presentació del seu contingut en una finestra o marc aliè a TDX (framing). Aquesta reserva de drets afecta tant al resum de presentació de la tesi com als seus continguts. En la utilització o cita de parts de la tesi és obligat indicar el nom de la persona autora.

ADVERTENCIA. La consulta de esta tesis queda condicionada a la aceptación de las siguientes condiciones de uso: La difusión de esta tesis por medio del servicio TDR (www.tesisenred.net) ha sido autorizada por los titulares de los derechos de propiedad intelectual únicamente para usos privados enmarcados en actividades de investigación y docencia. No se autoriza su reproducción con finalidades de lucro ni su difusión y puesta a disposición desde un sitio ajeno al servicio TDR. No se autoriza la presentación de su contenido en una ventana o marco ajeno a TDR (framing). Esta reserva de derechos afecta tanto al resumen de presentación de la tesis como a sus contenidos. En la utilización o cita de partes de la tesis es obligado indicar el nombre de la persona autora.

WARNING. On having consulted this thesis you're accepting the following use conditions: Spreading this thesis by the TDX (www.tesisenxarxa.net) service has been authorized by the titular of the intellectual property rights only for private uses placed in investigation and teaching activities. Reproduction with lucrative aims is not authorized neither its spreading and availability from a site foreign to the TDX service. Introducing its content in a window or frame foreign to the TDX service is not authorized (framing). This rights affect to the presentation summary of the thesis as well as to its contents. In the using or citation of parts of the thesis it's obliged to indicate the name of the author.

UNIVERSITAT DE BARCELONA
ESTUDI GENERAL DE LLEIDA
FACULTAT DE LLETRES

ASSIMILACIÓ, RESISTÈNCIA I CANVI A LA ROMANITZACIÓ
EN EL MÓN ILERGET.

(Aproximació a l'Horitzó Ibèric Tardà i les seves pervivències a les comarques de plana de les províncies d'Osca i Lleida).

Tesi presentada per aspirar al títol de Doctor per

IGNASI GARCÉS I ESTALLO

Direcció: Dr. EMILI JUNYENT I SANCHEZ

Professor Titular de Prehistòria

Secció d'Arqueologia, Prehistòria i Història Antiga,

Dpt. de Geografia i Història. Estudi General de Lleida.

Lleida, octubre de 1990

Tesi doctoral d'Ignasi Garcia, 2ª part

10. APÈNDIX DE FIGURES I FOTOGRAFIES



FIGURA 182



FIGURA 183

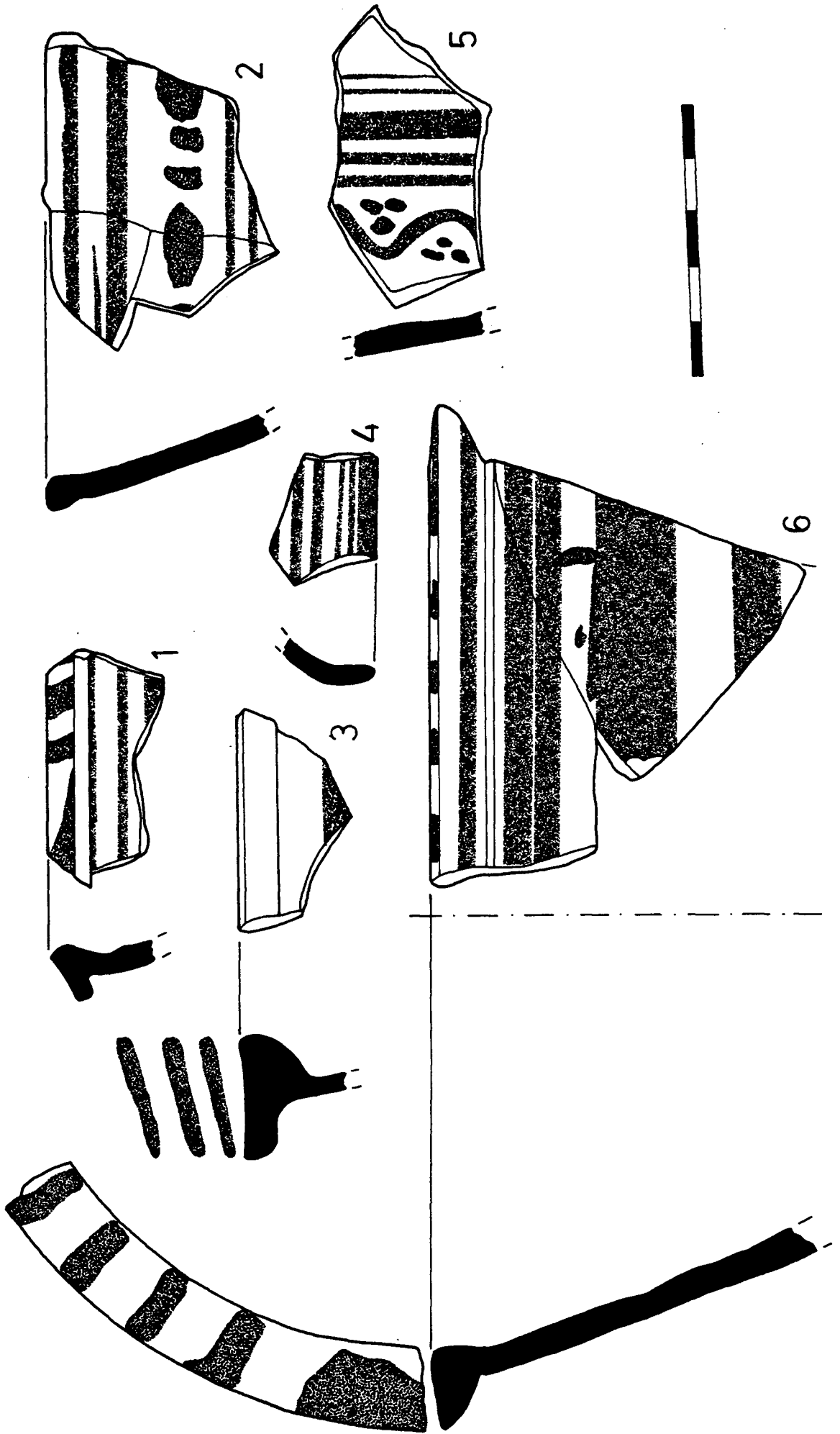

FIGURA 184

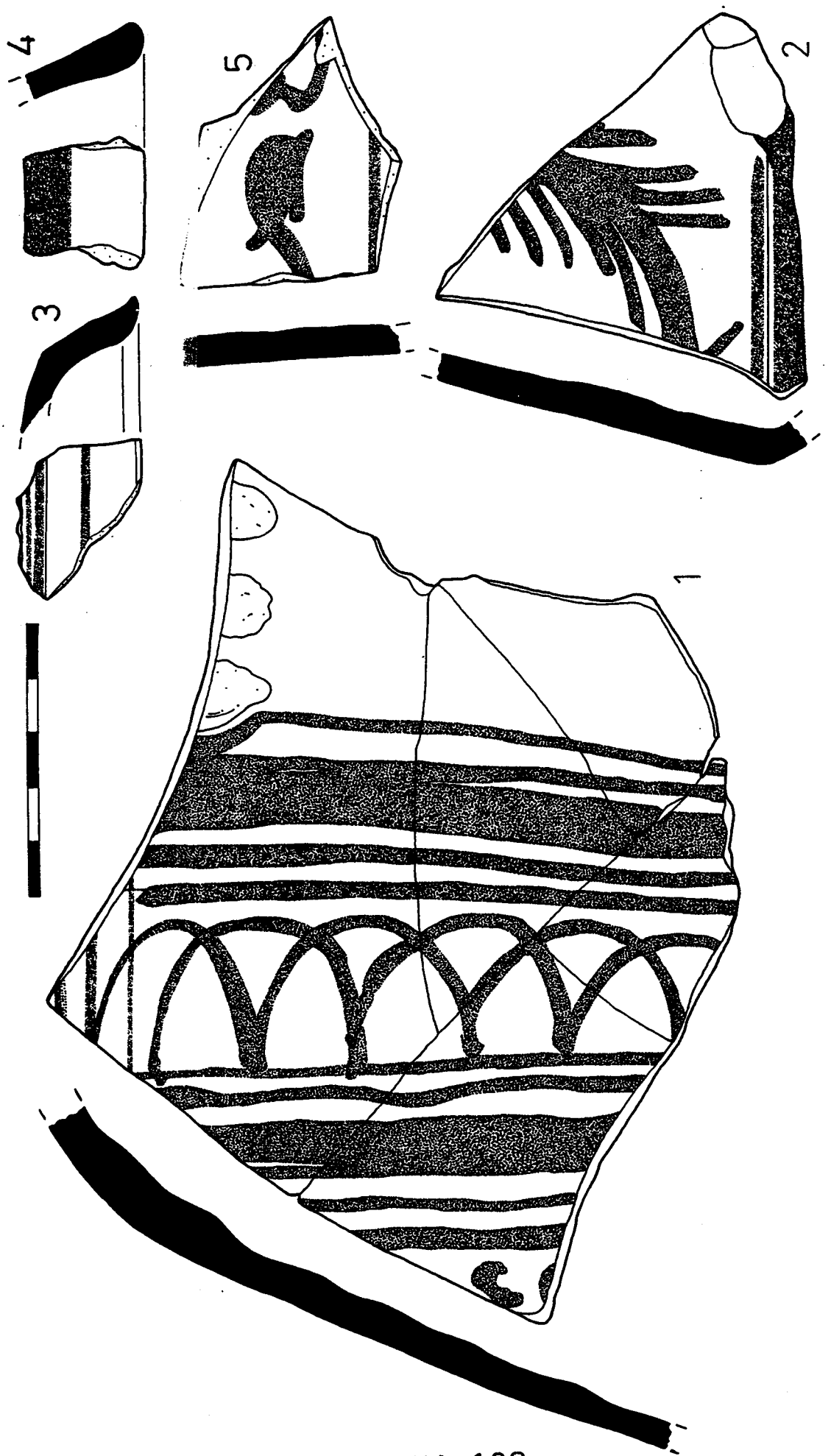

FIGURA 185

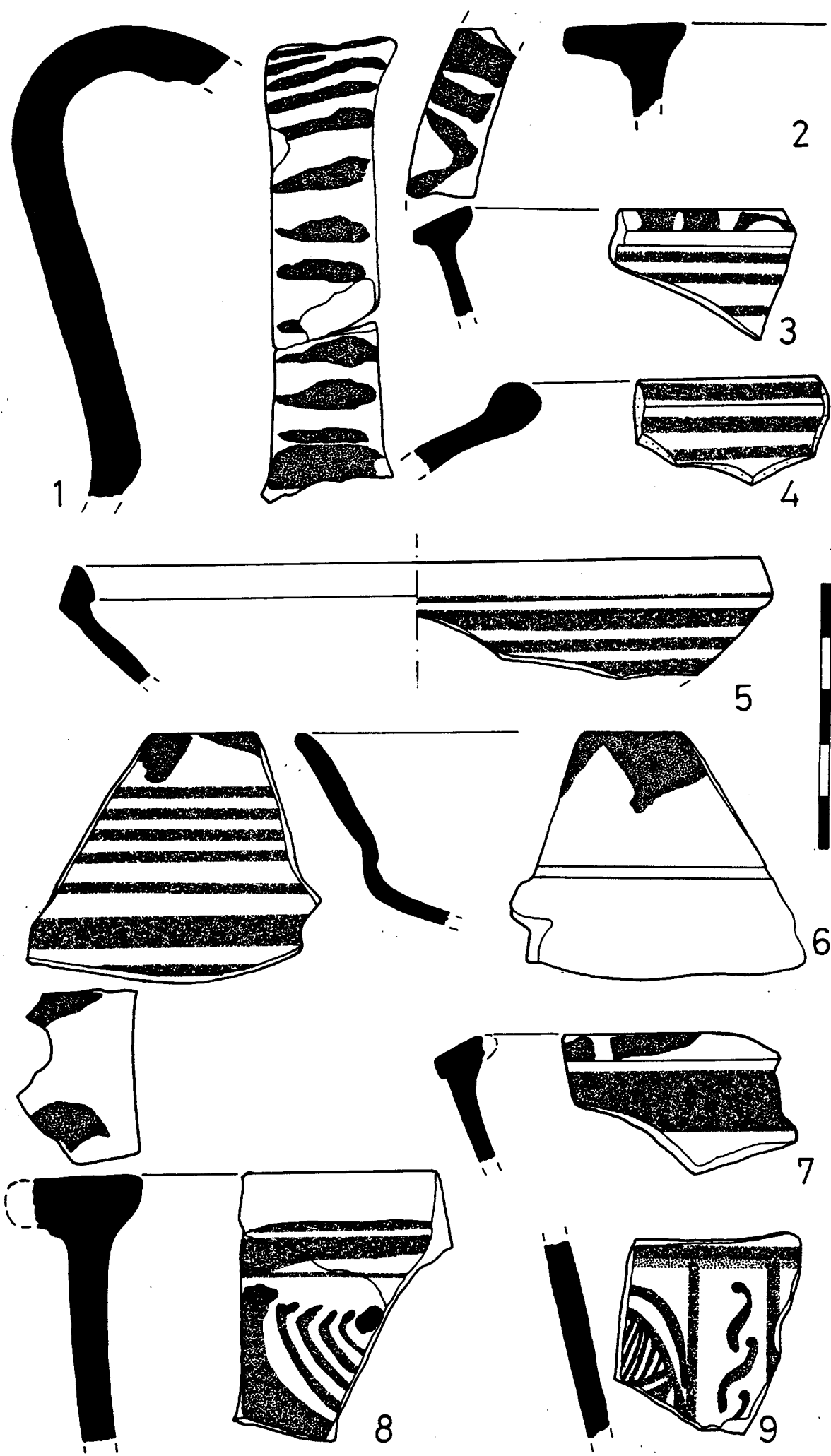

FIGURA 186

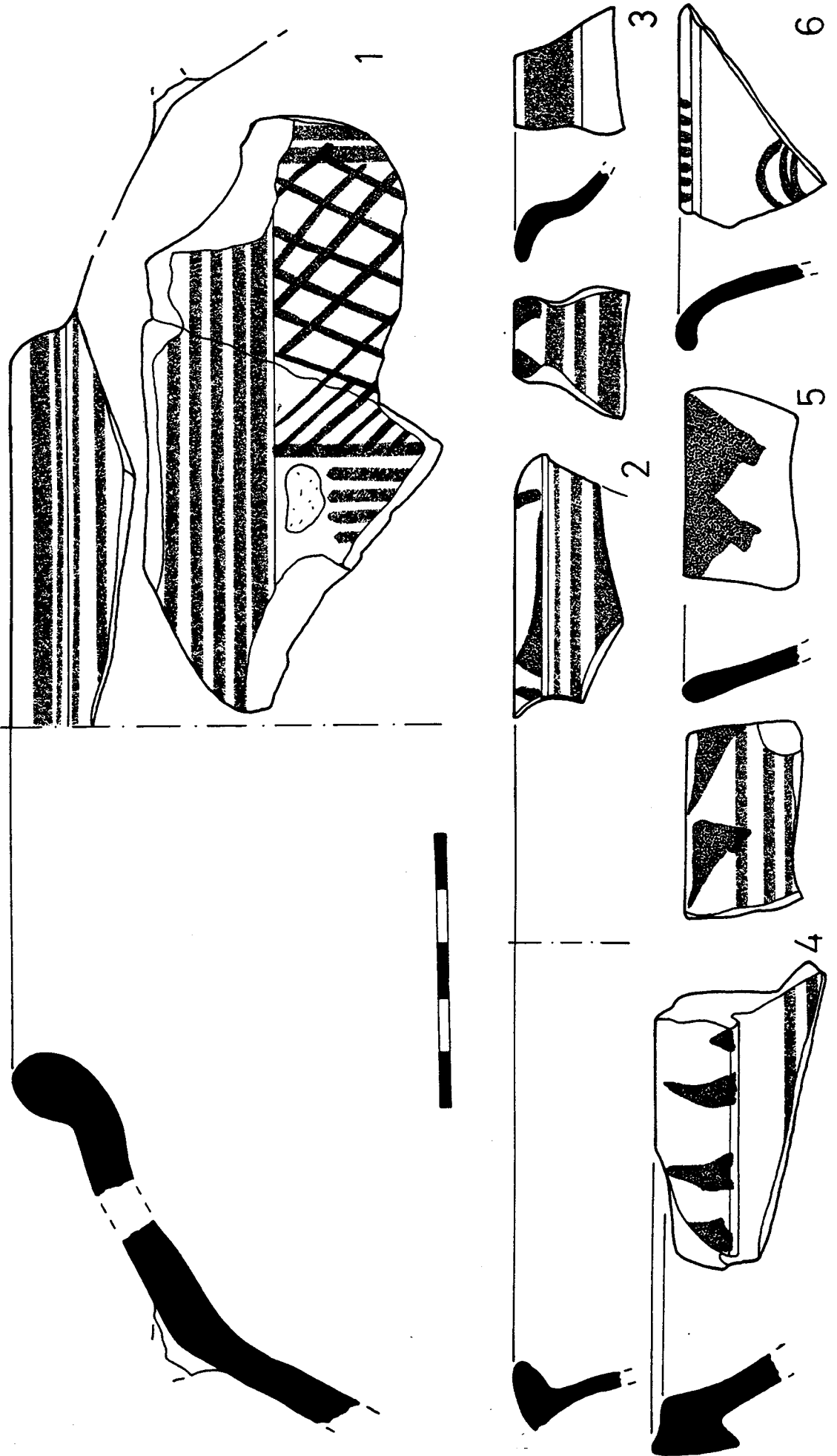

FIGURA 187

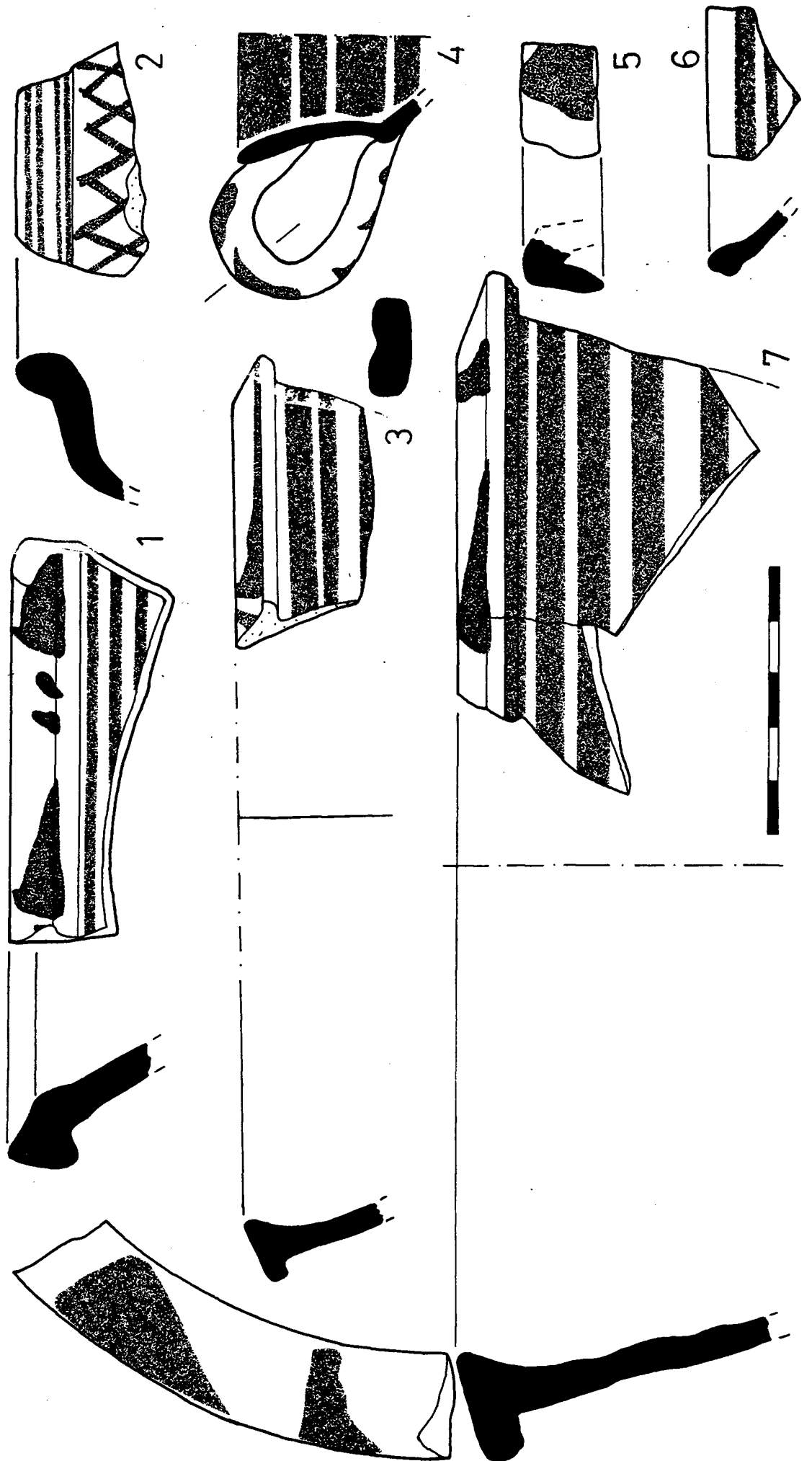

FIGURA 188

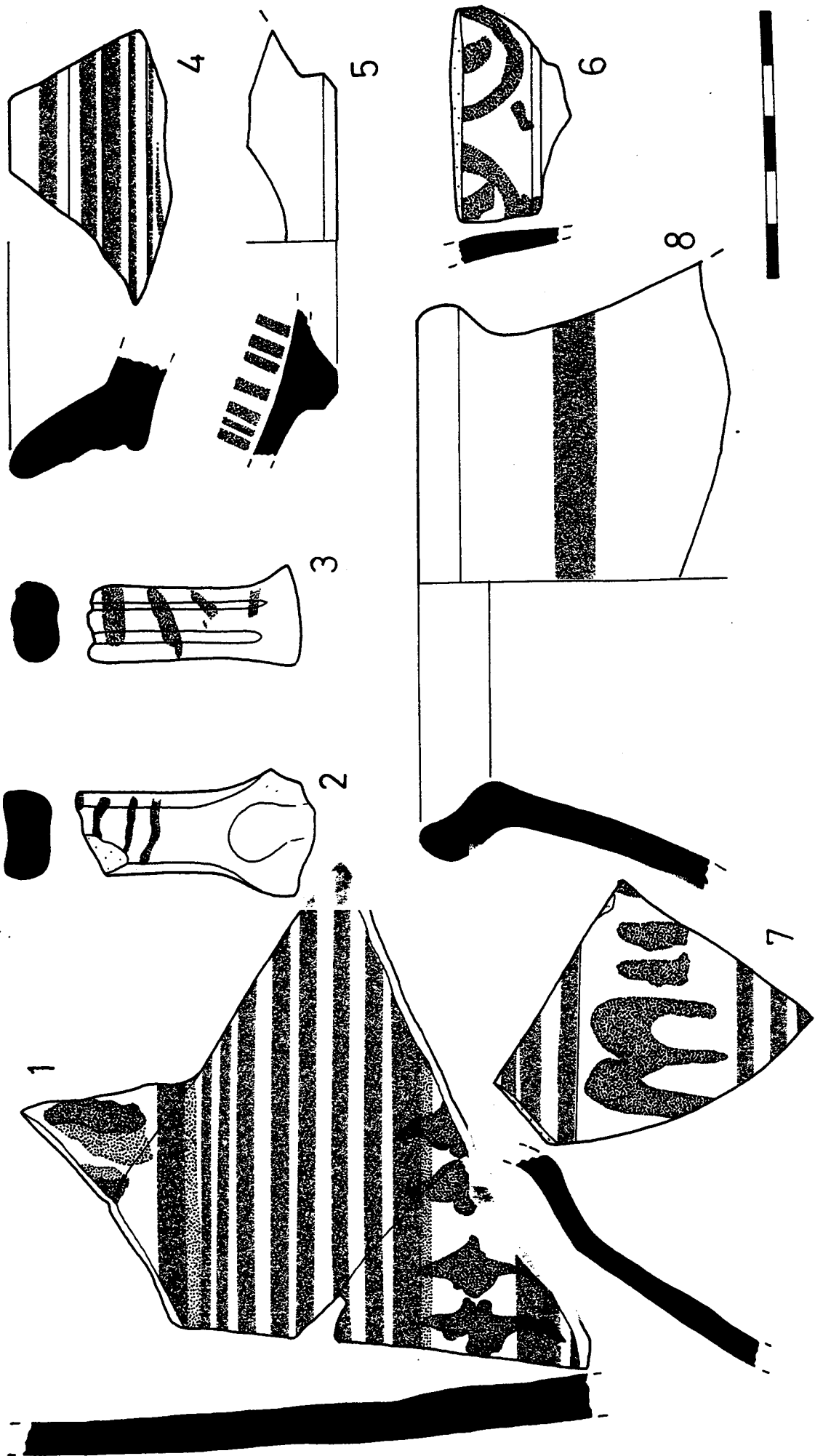

FIGURA 189

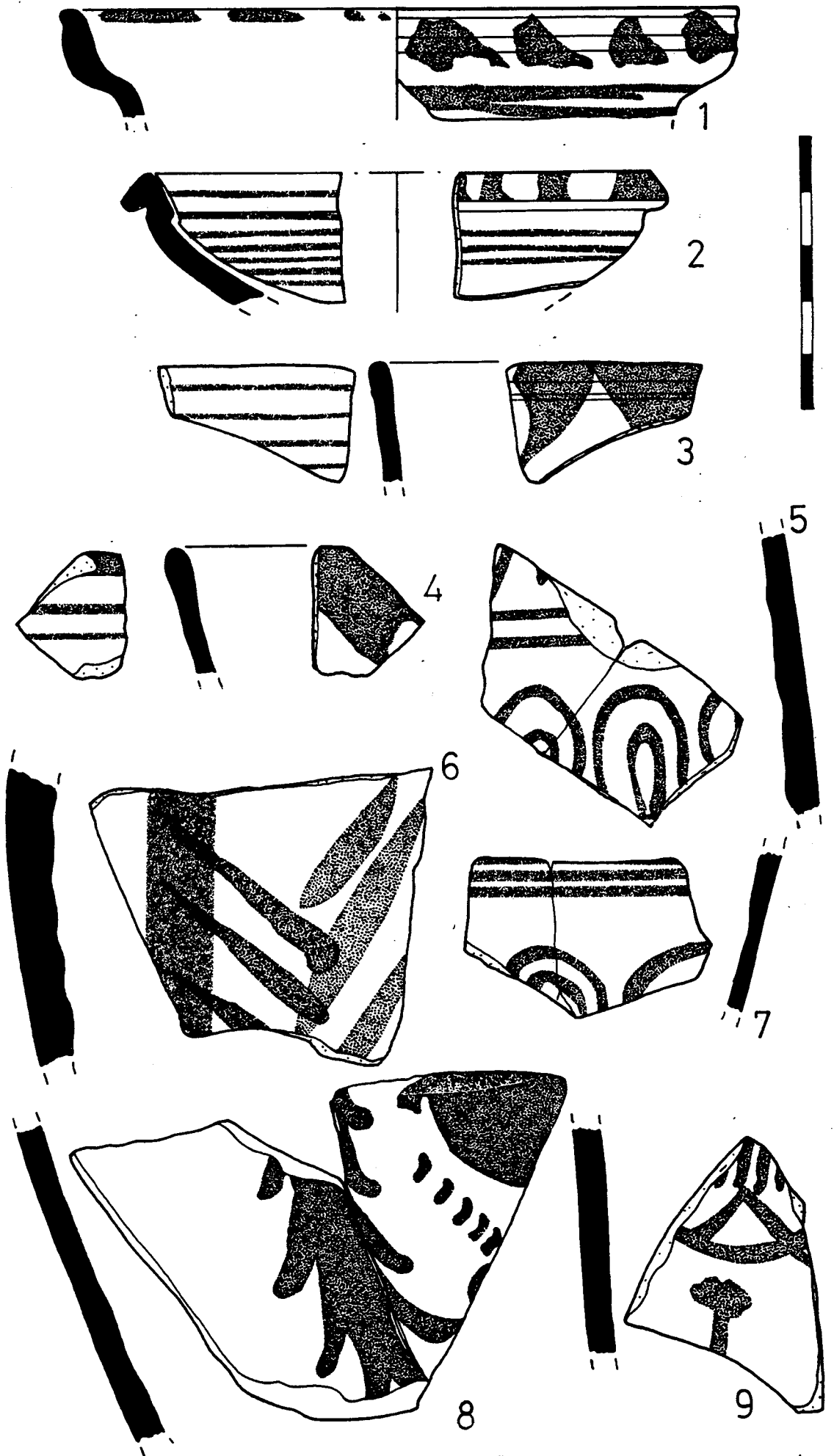

FIGURA 190

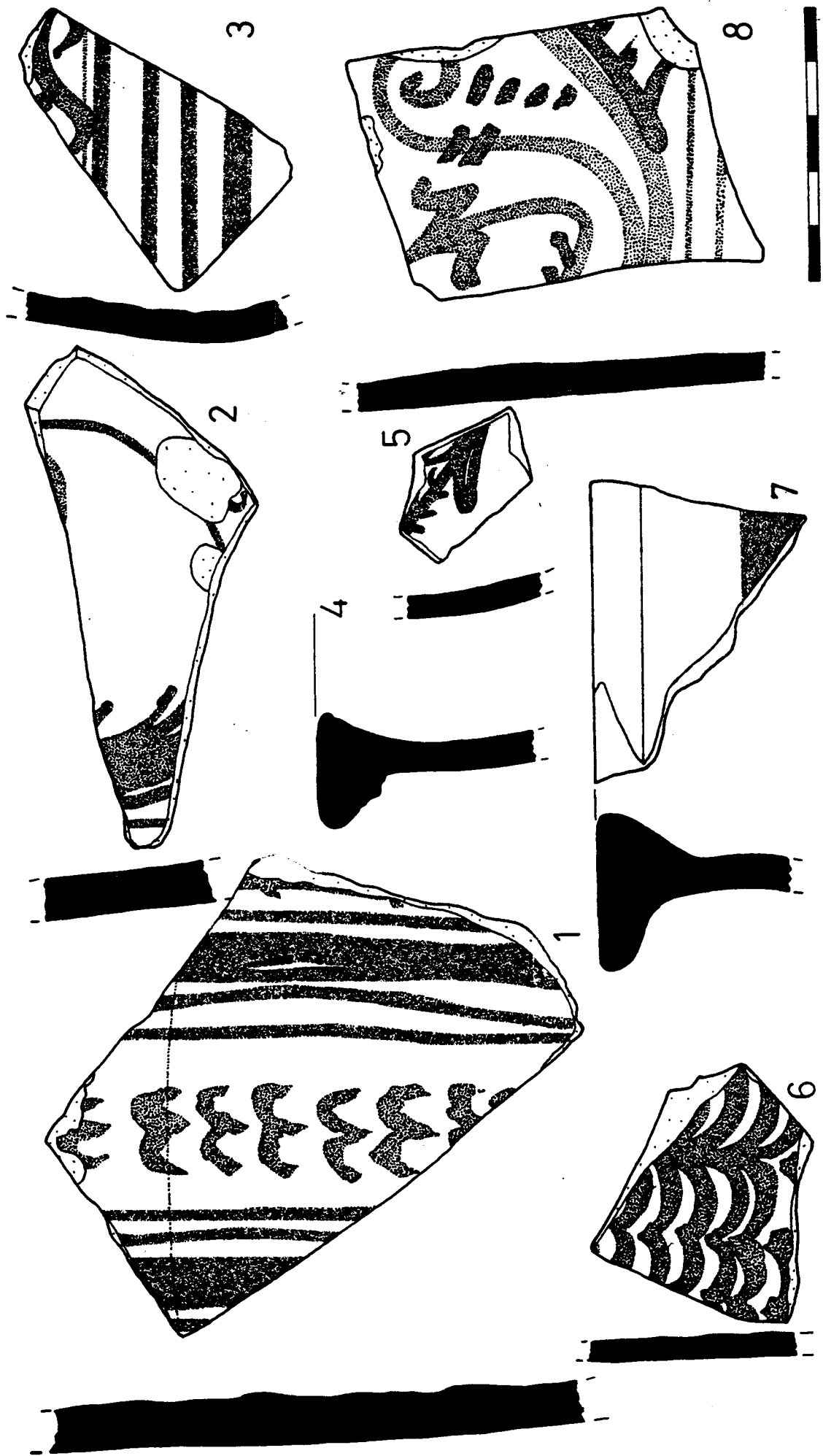

FIGURA 191

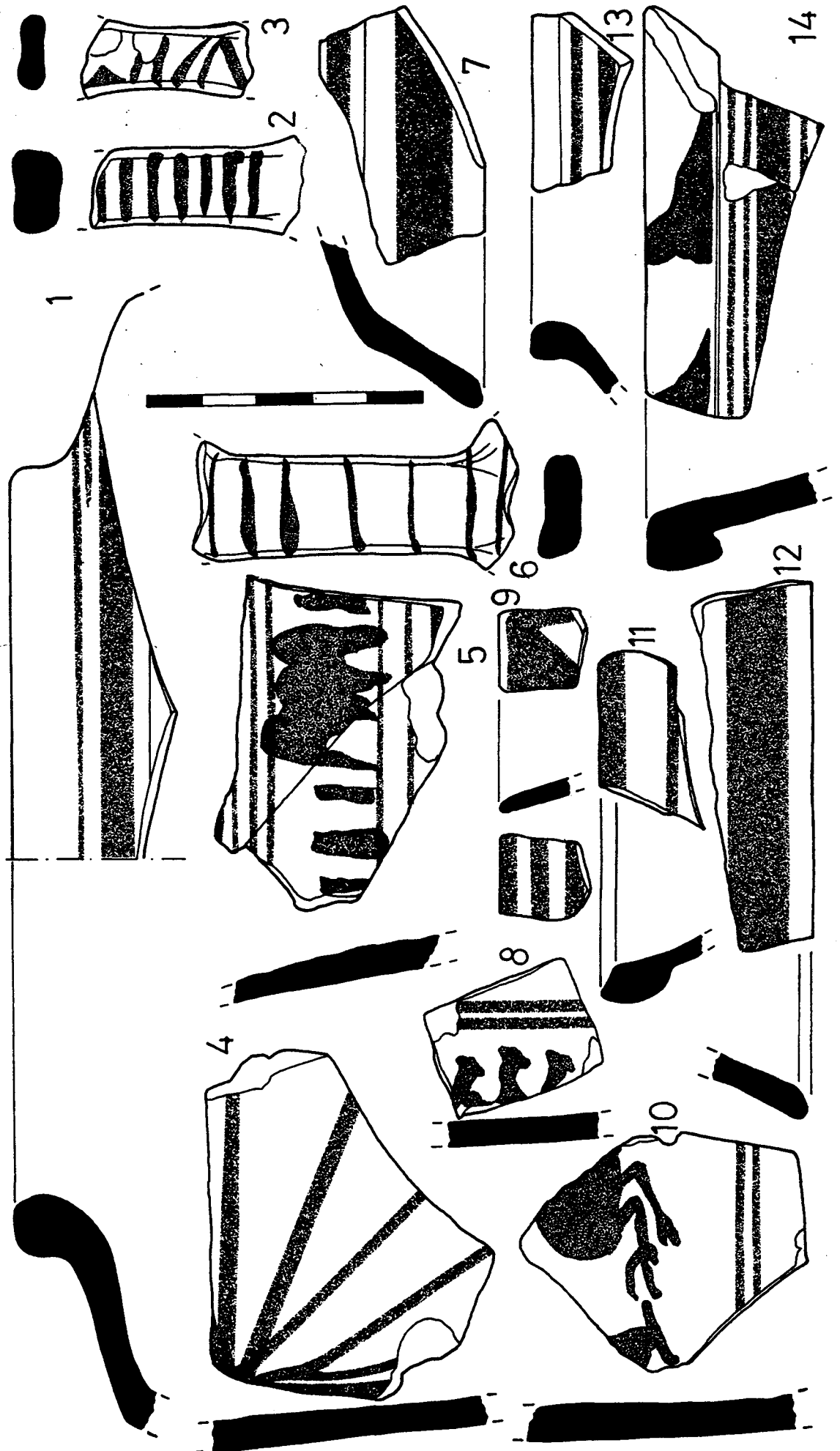

FIGURA 192

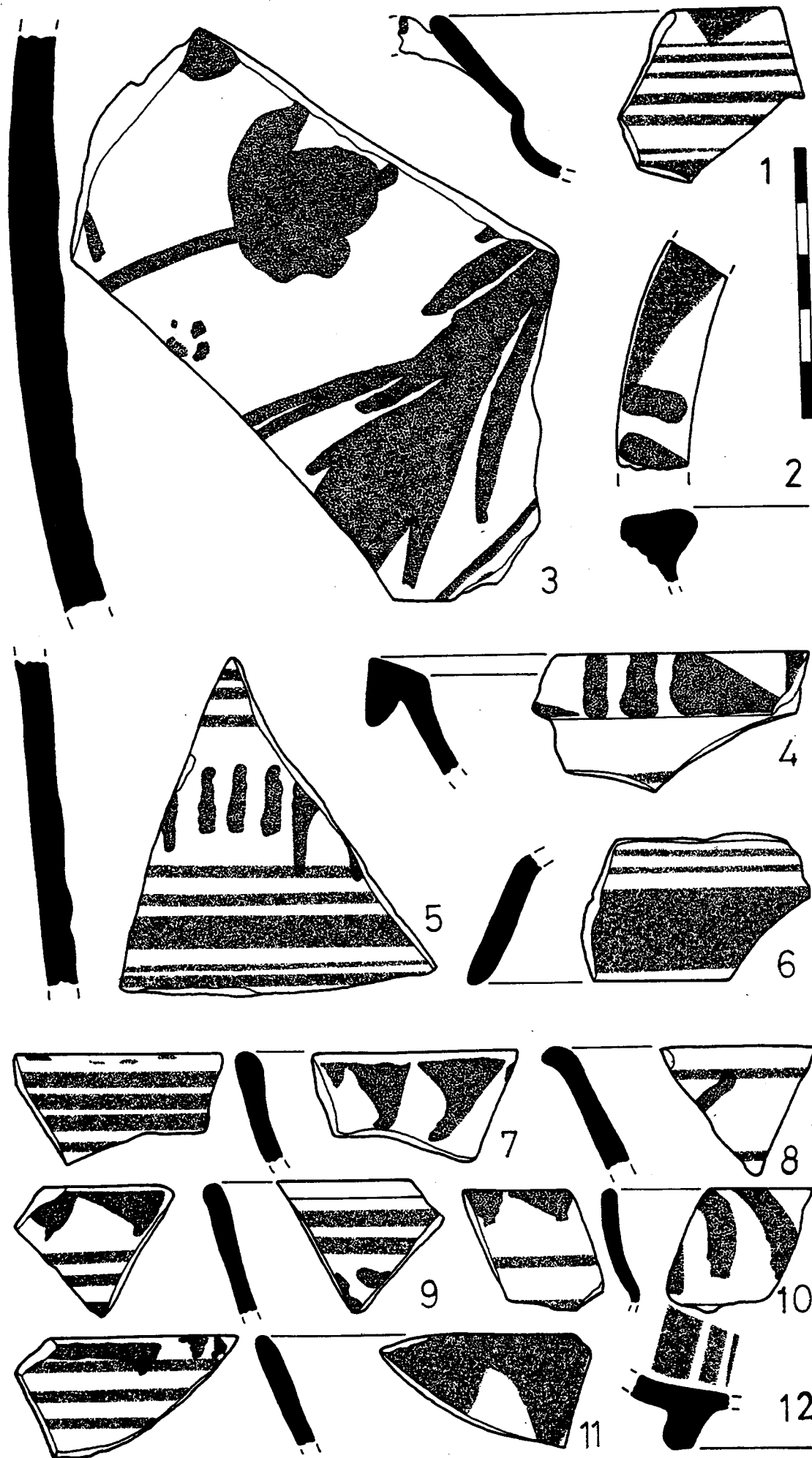

FIGURA 193

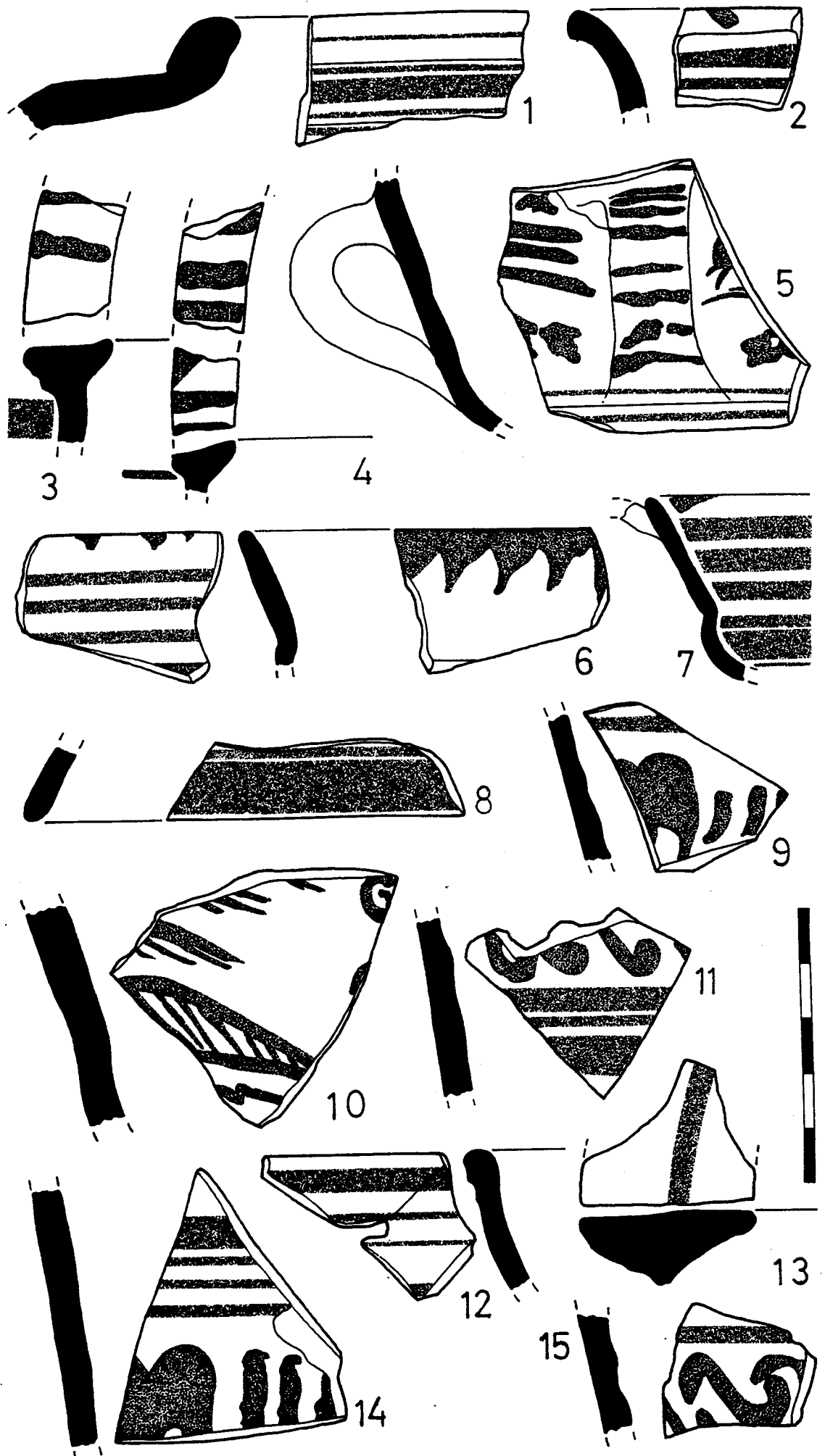

FIGURA 194

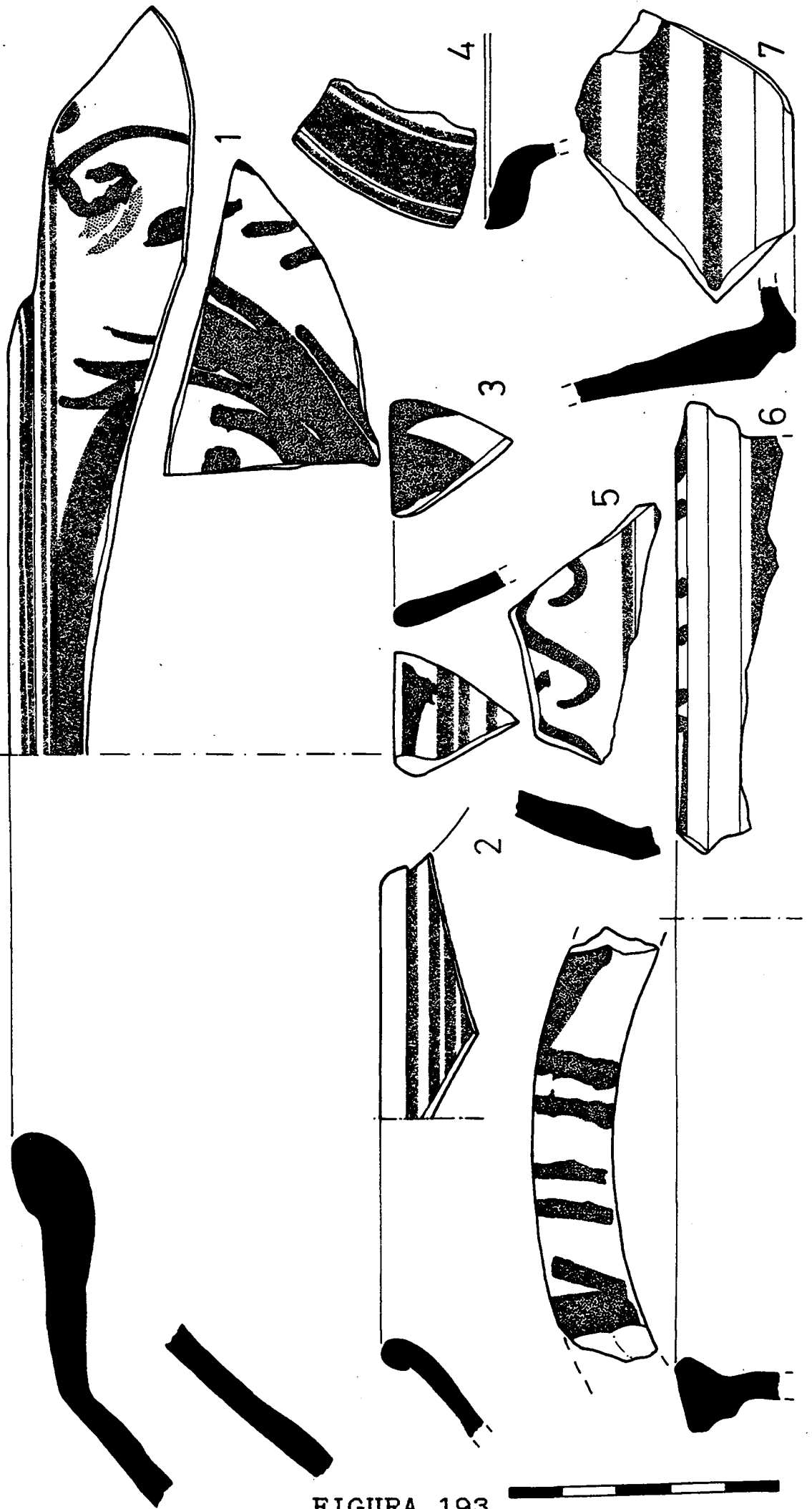

FIGURA 195

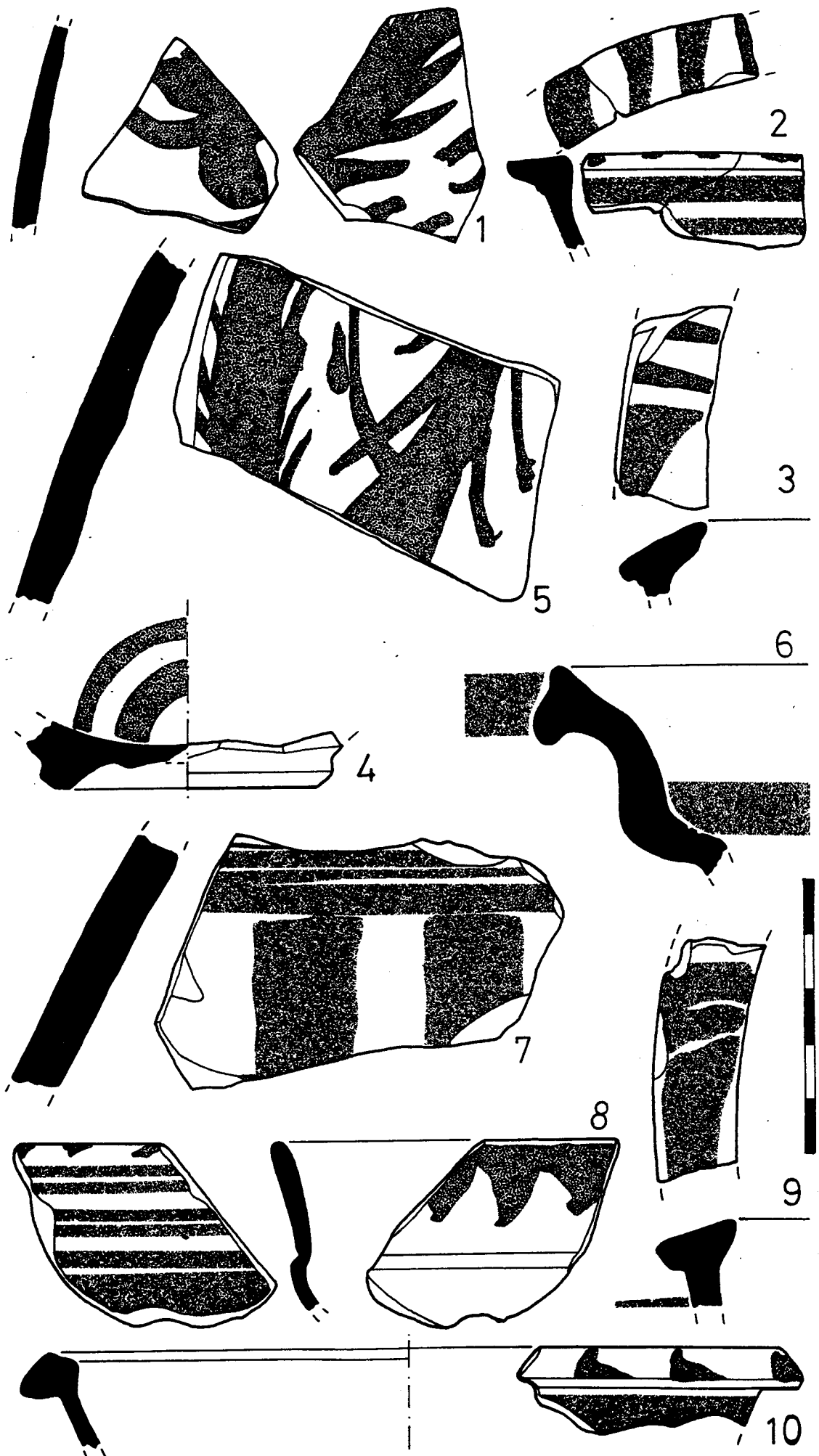

FIGURA 196

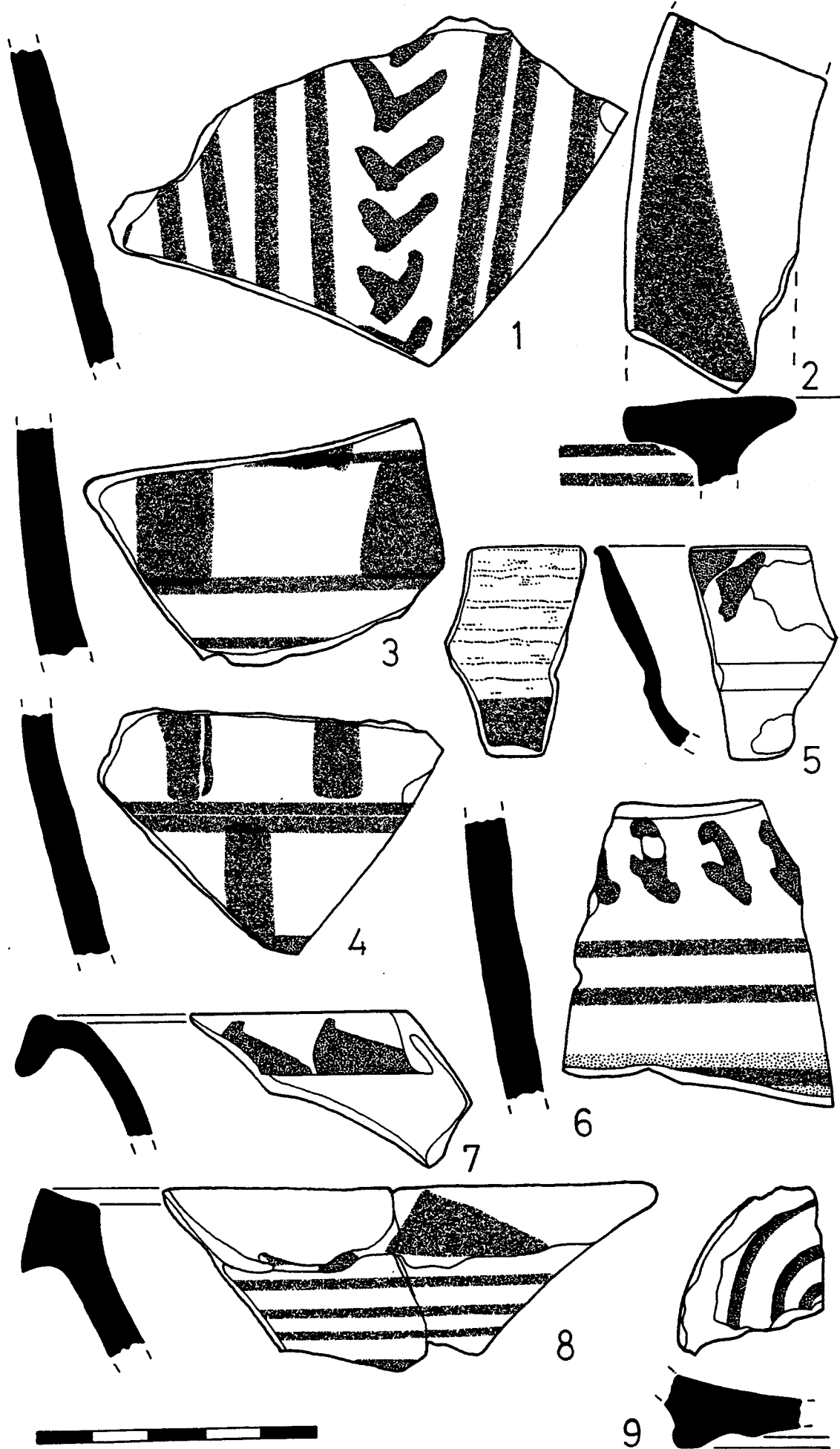

FIGURA 197

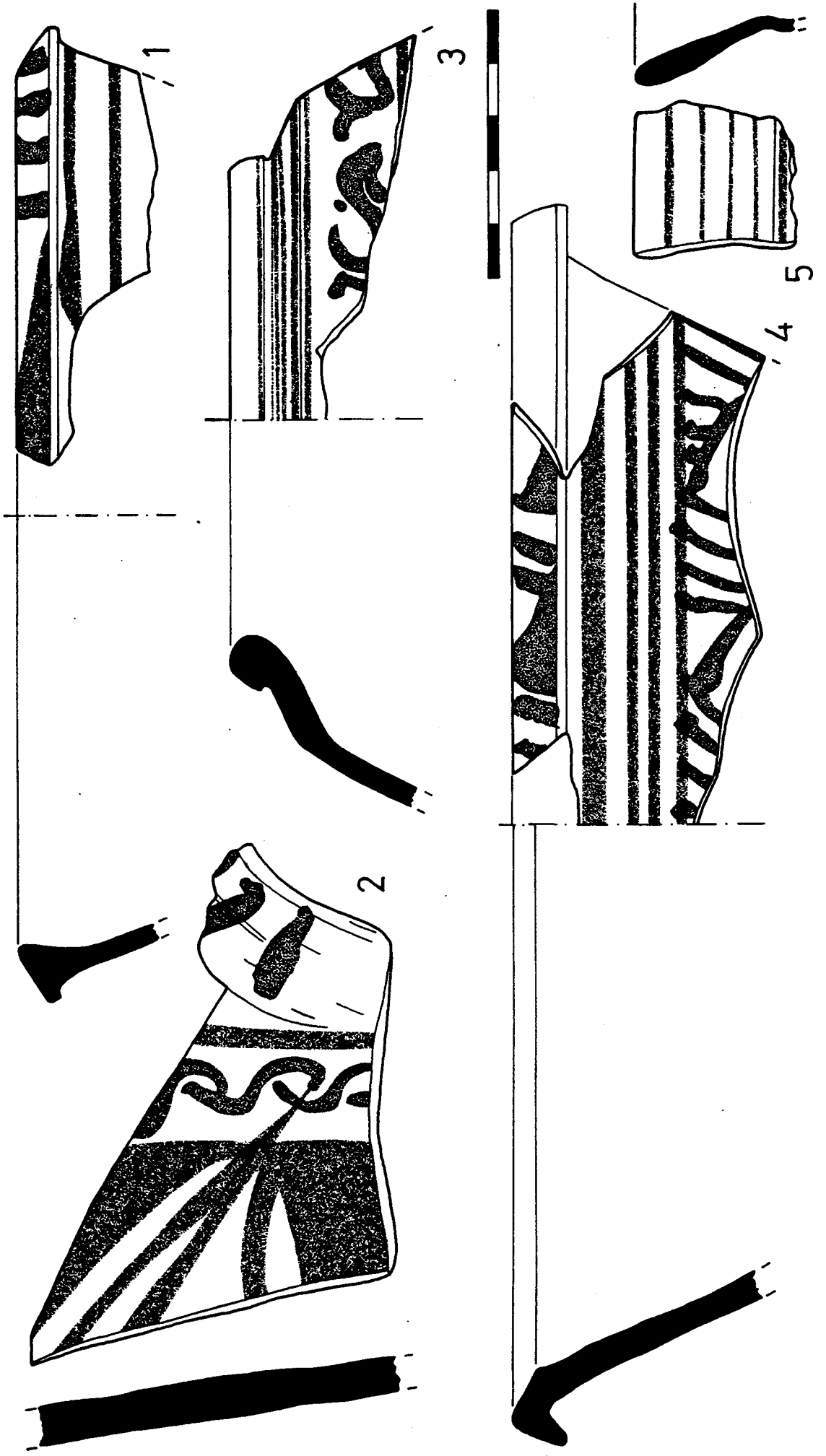

FIGURA 198

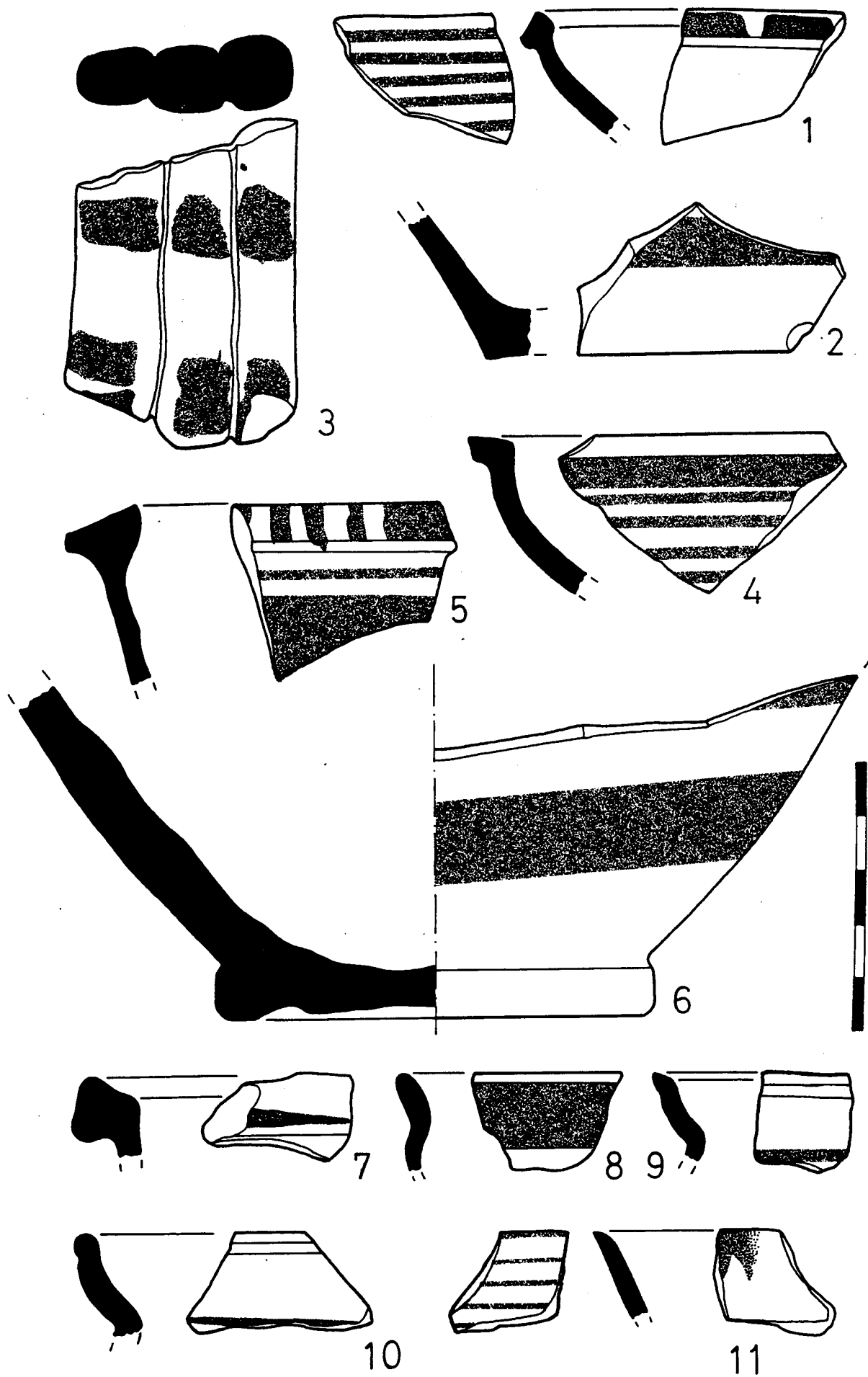

FIGURA 199

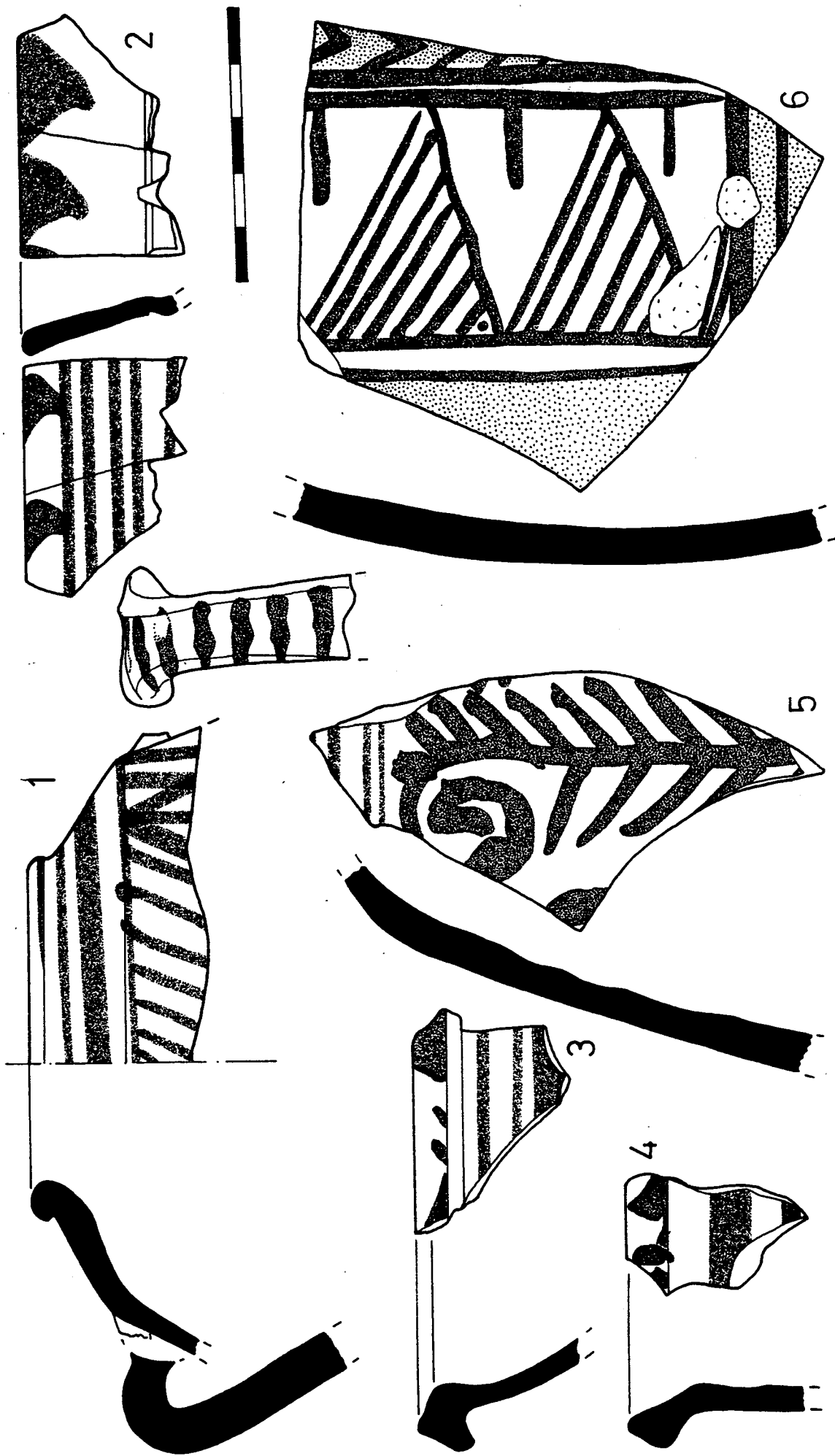

FIGURA 200

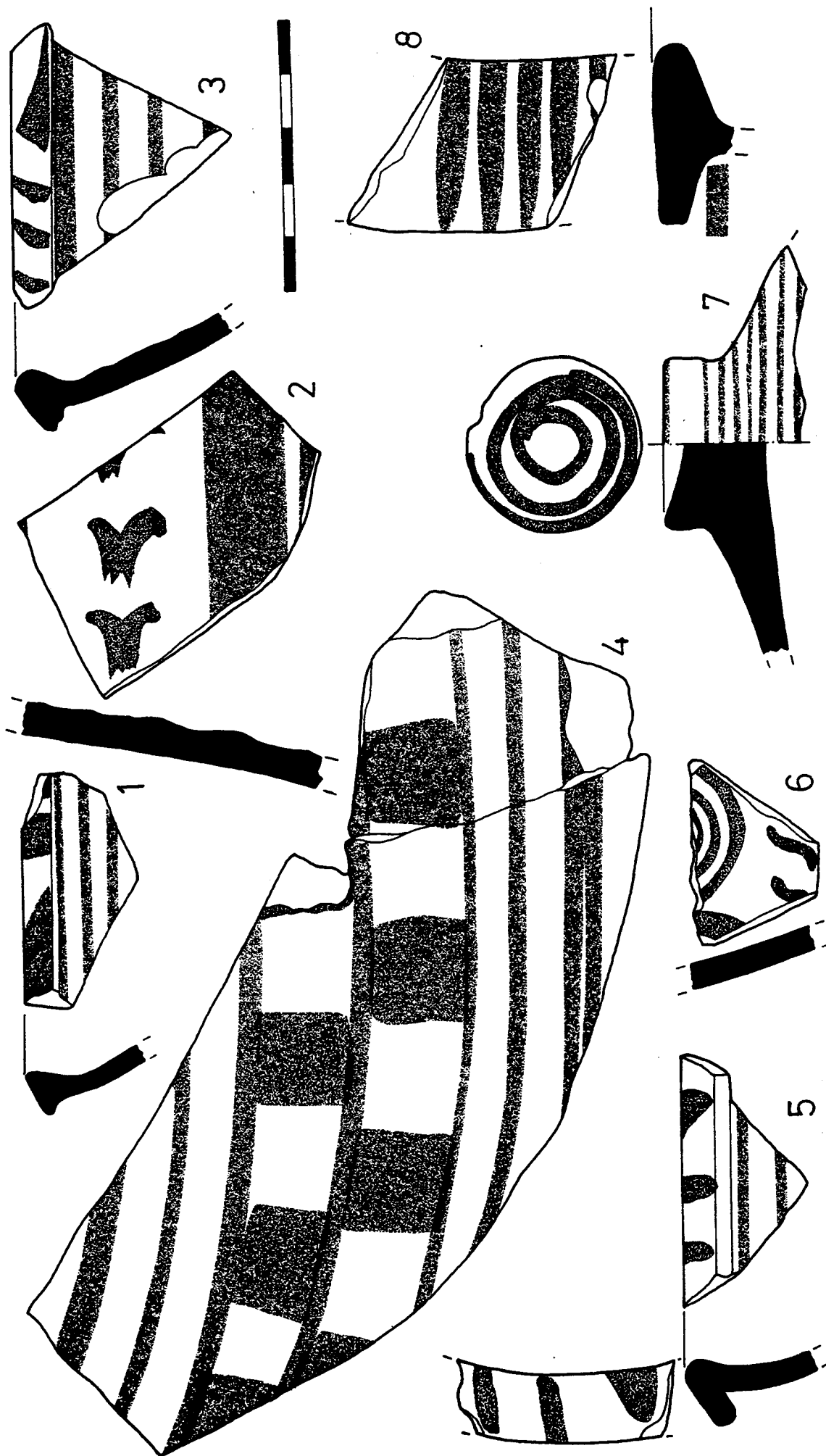

FIGURA 201

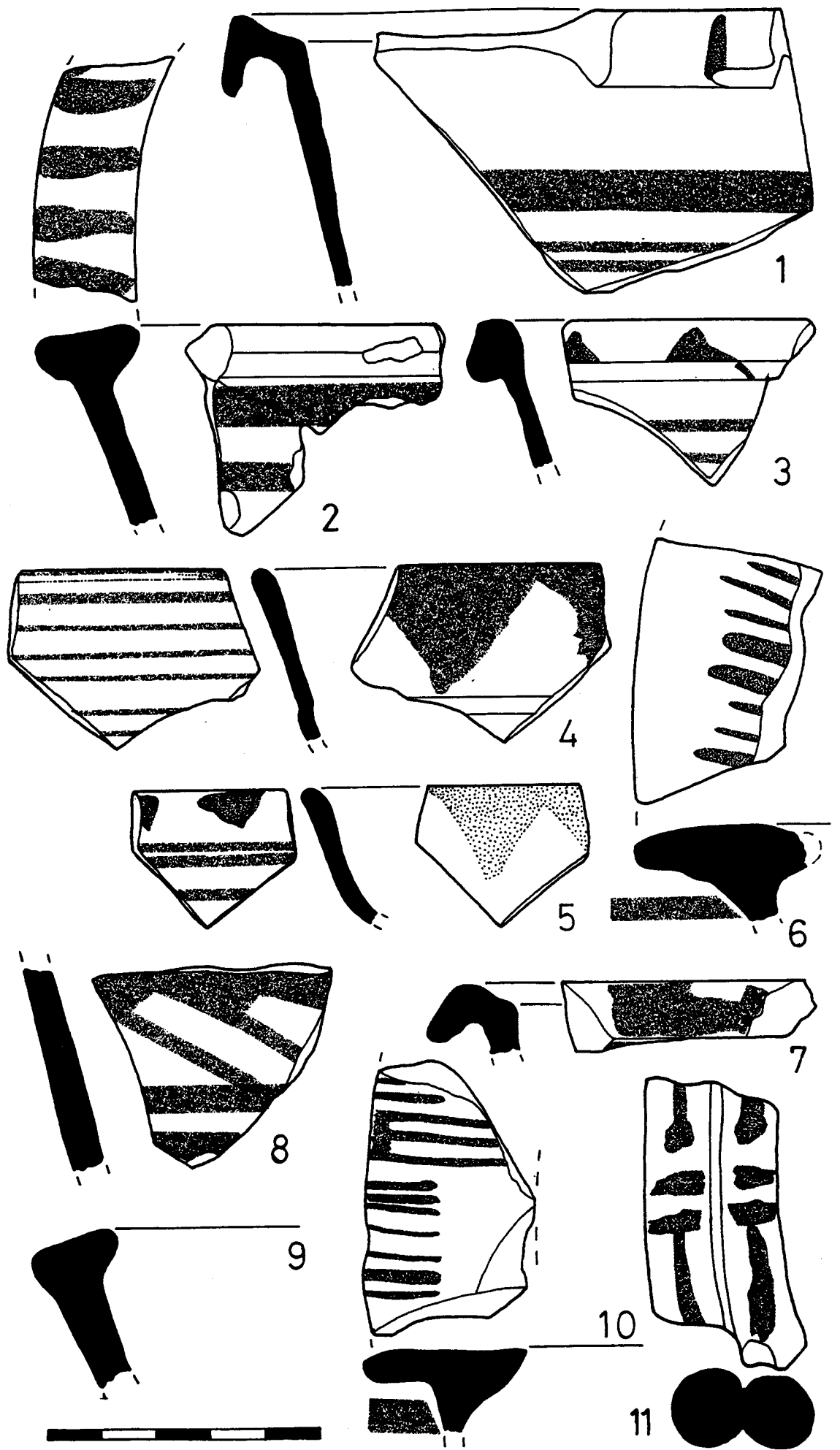

FIGURA 202

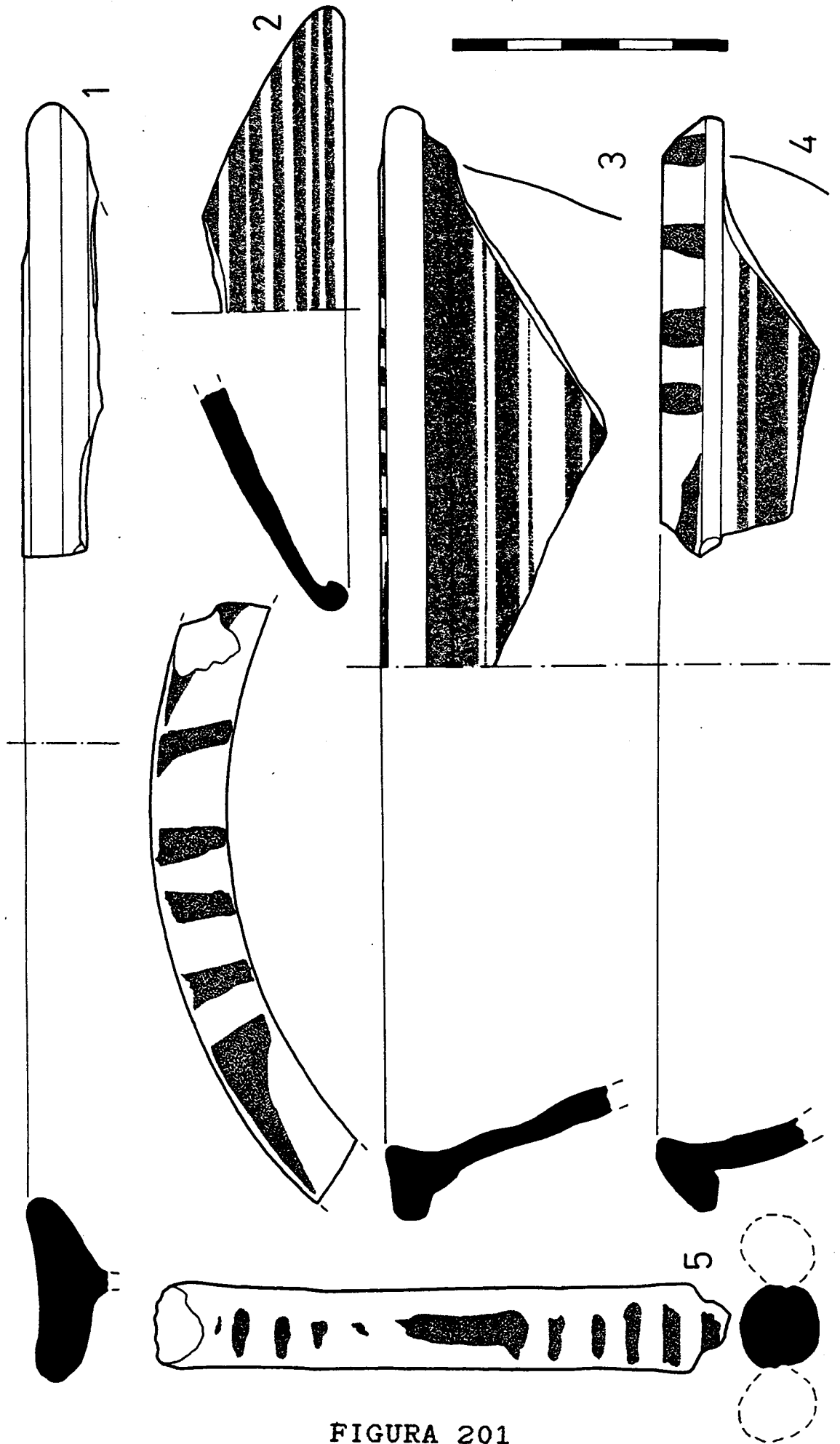

FIGURA 203

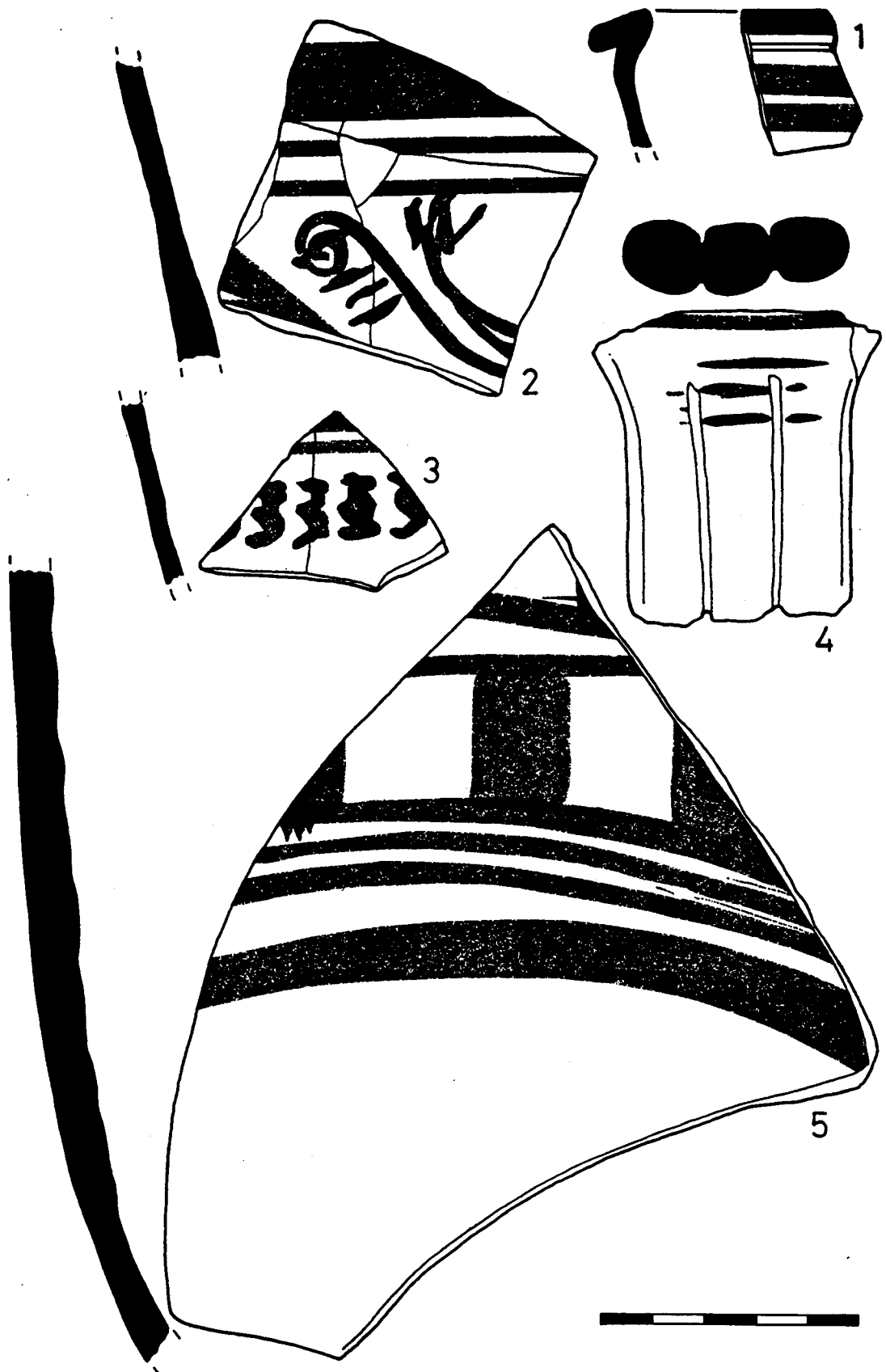

FIGURA 204

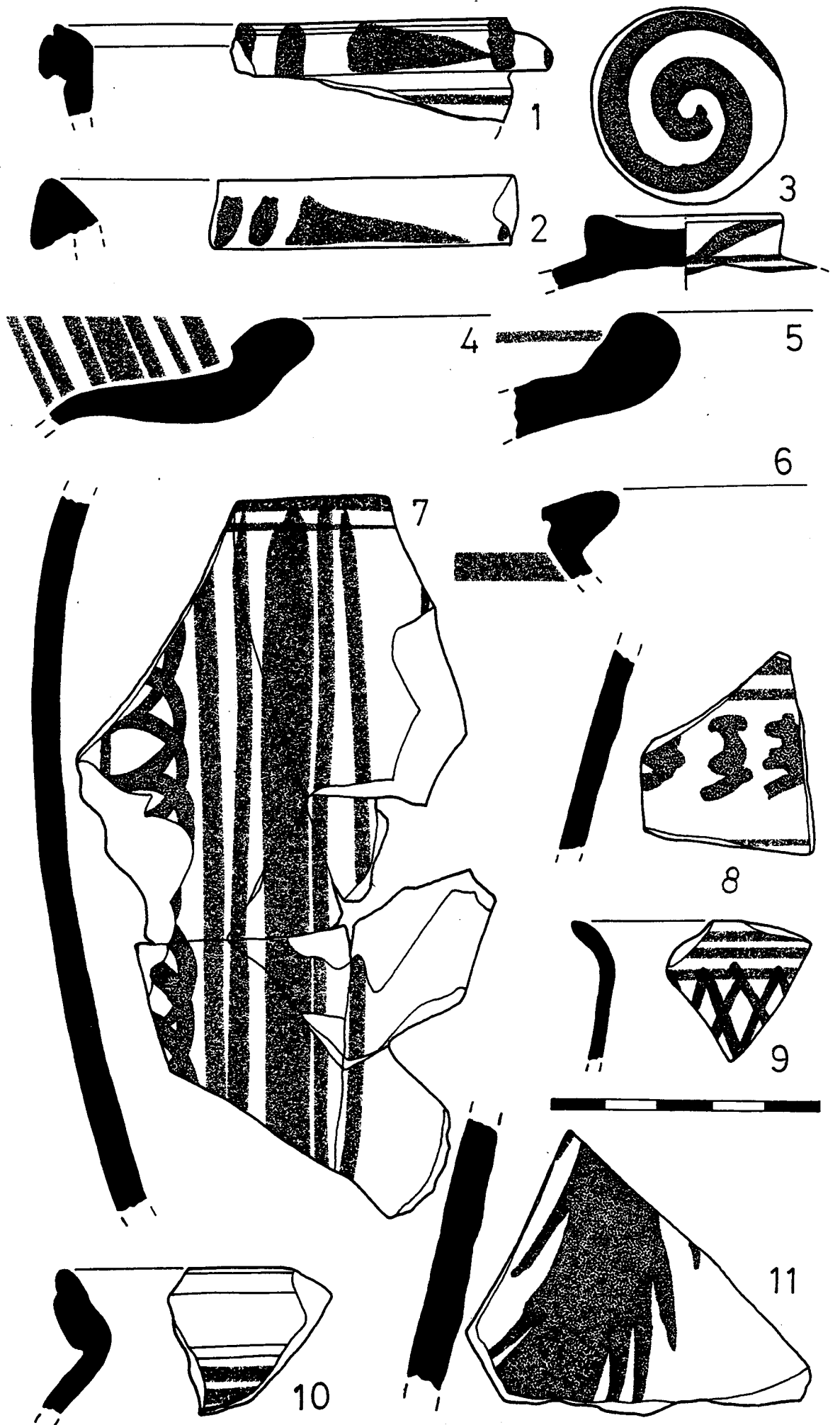

FIGURA 205

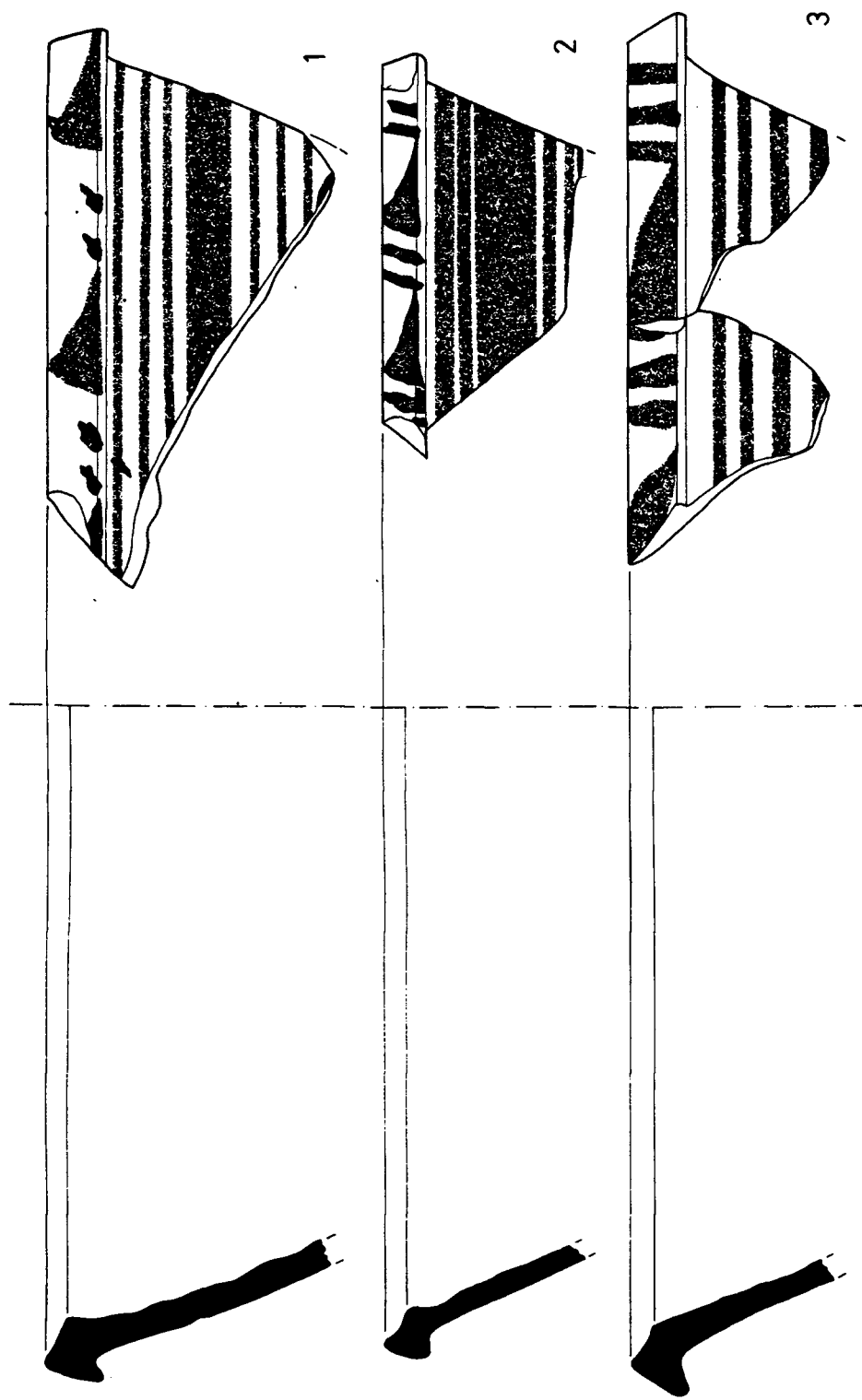

FIGURA 206

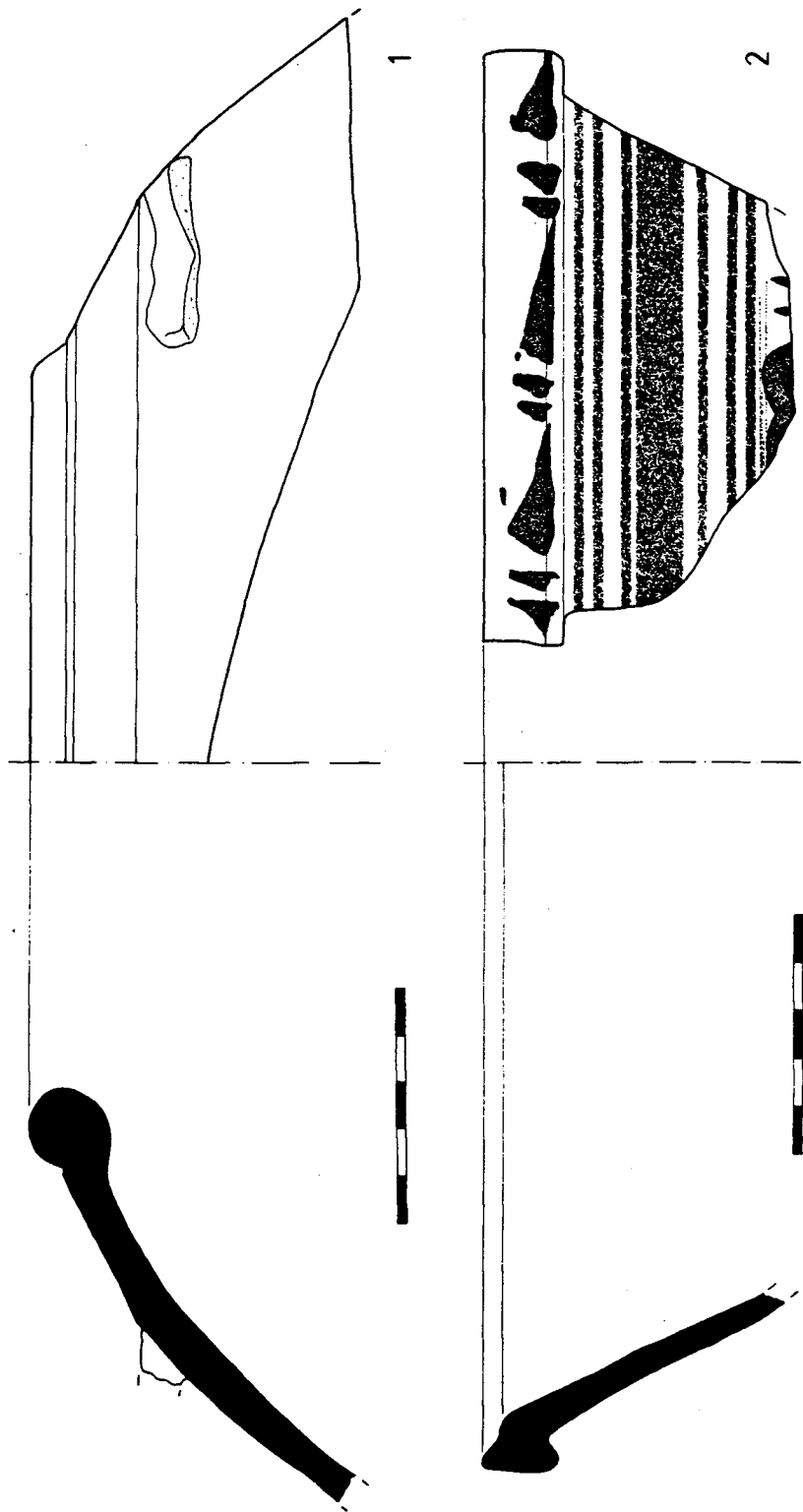

FIGURA 207

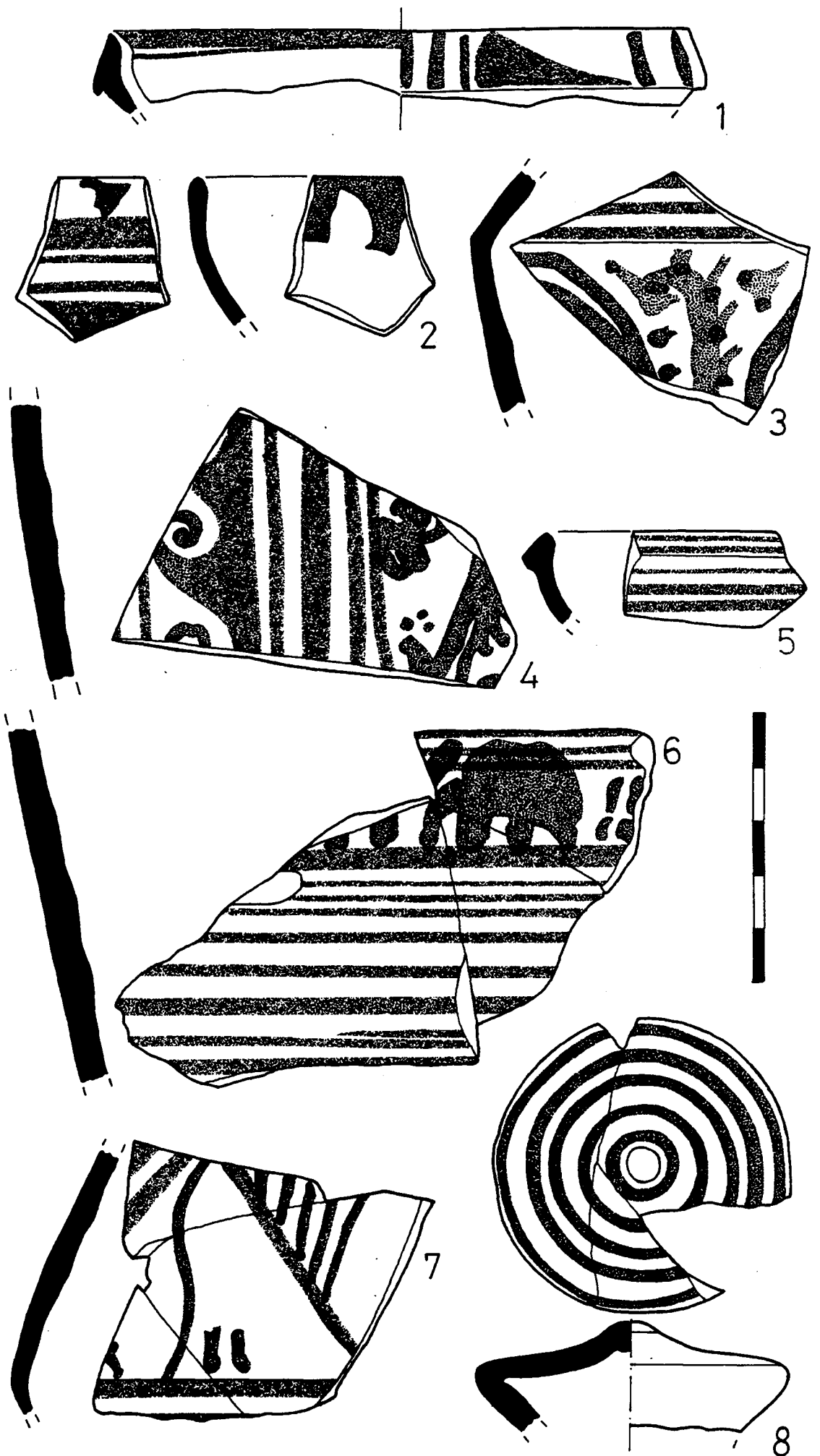

FIGURA 208

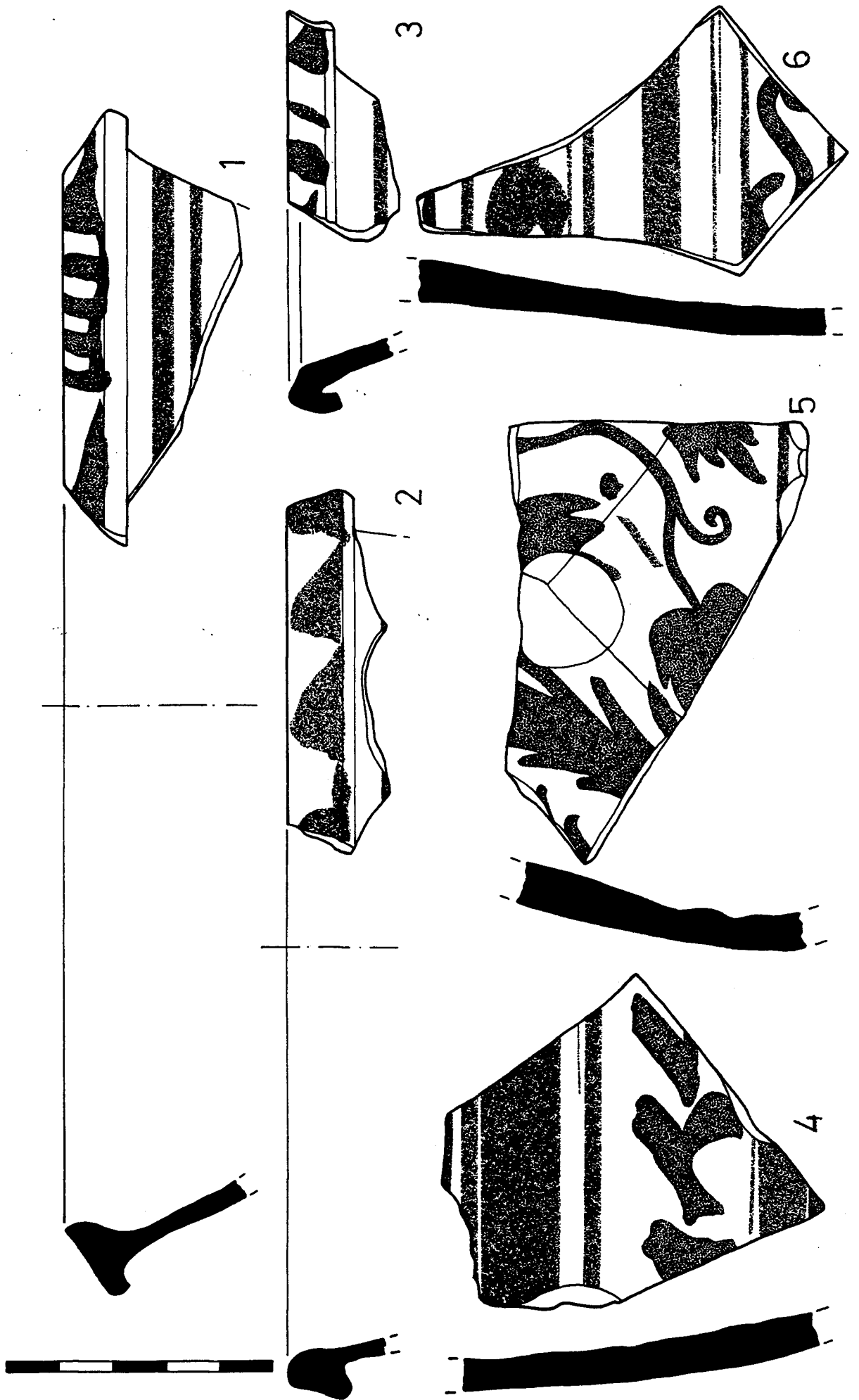

FIGURA 209

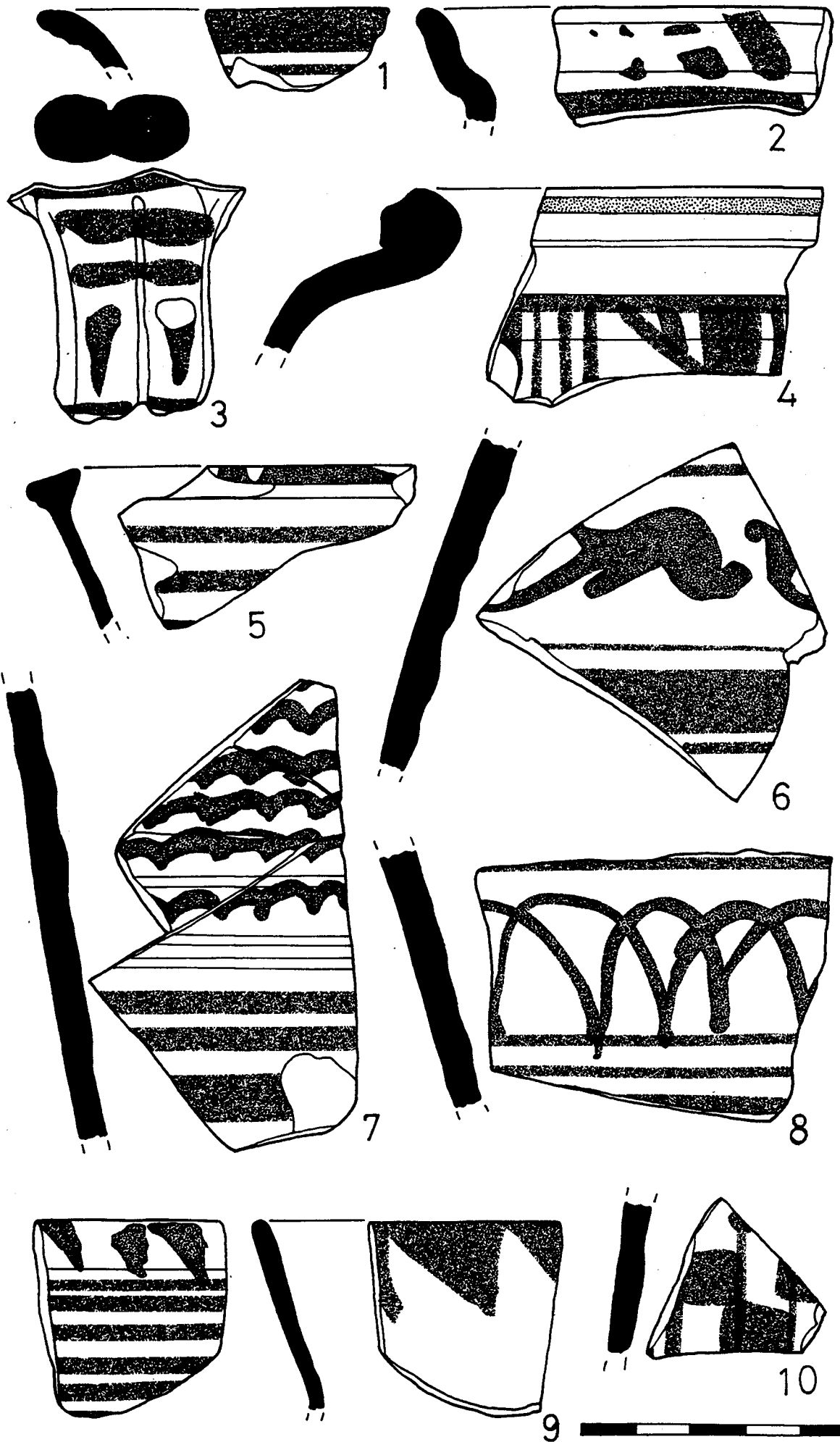

FIGURA 210

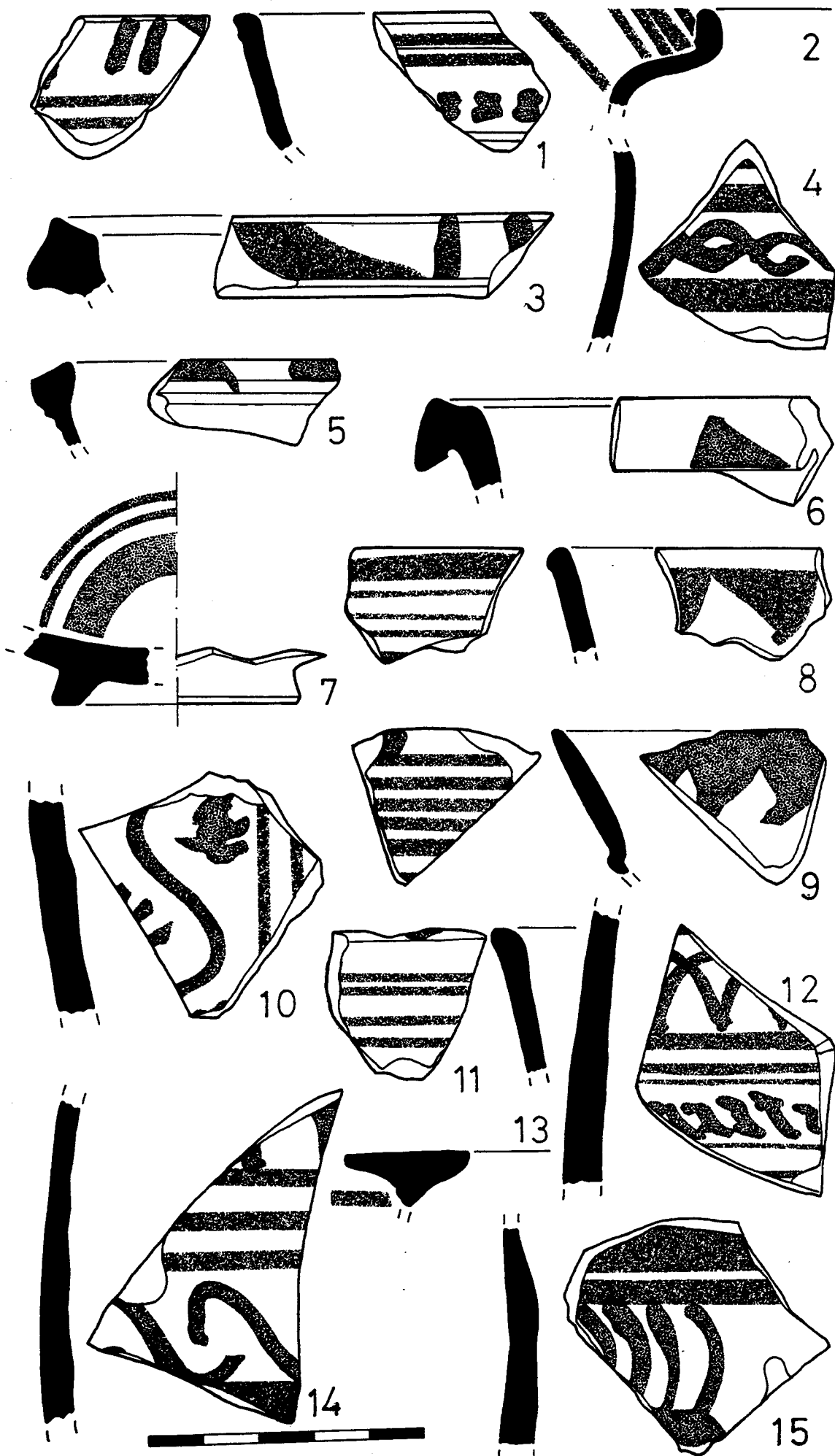

FIGURA 211

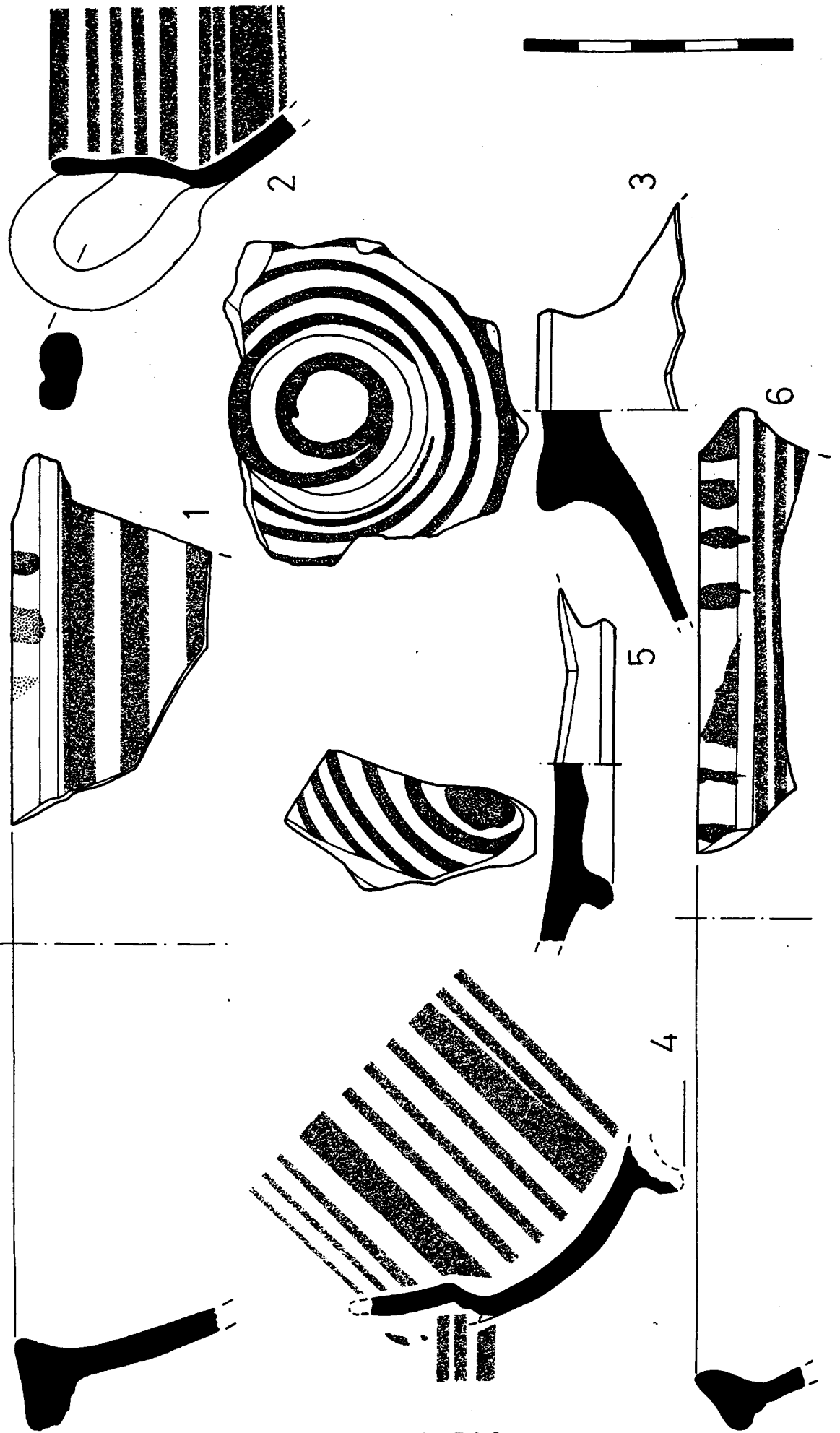

FIGURA 212

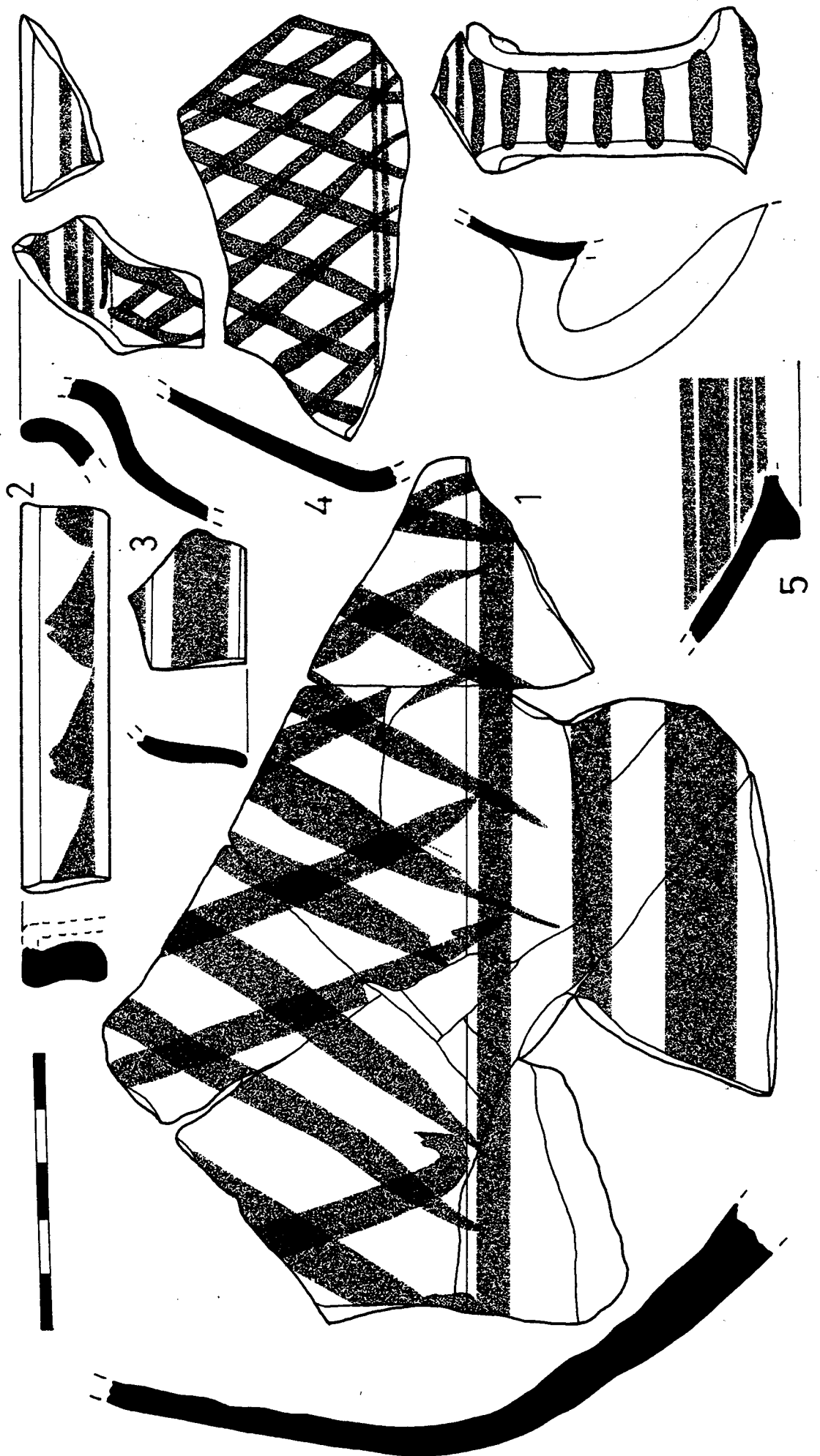

FIGURA 213

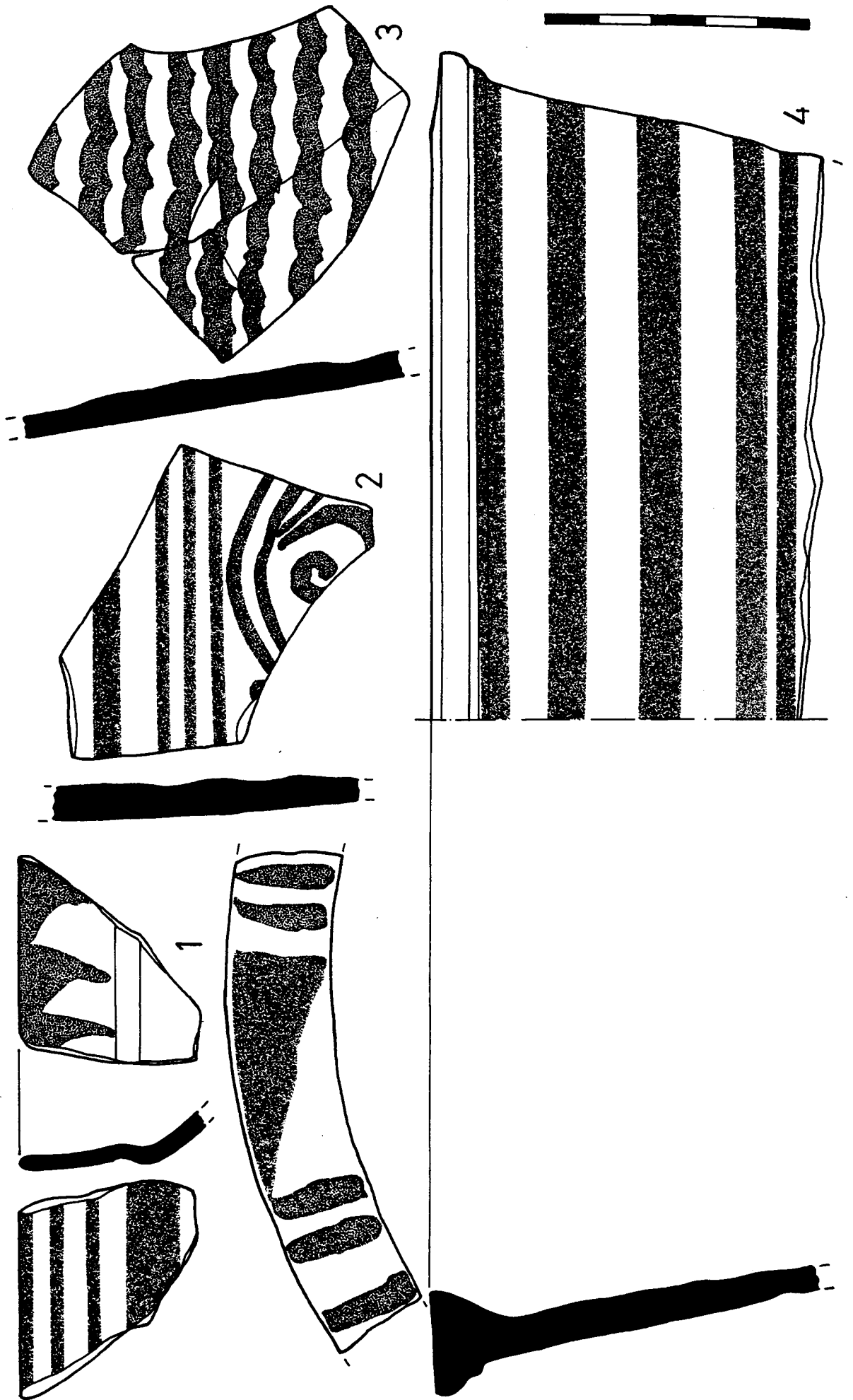

FIGURA 214

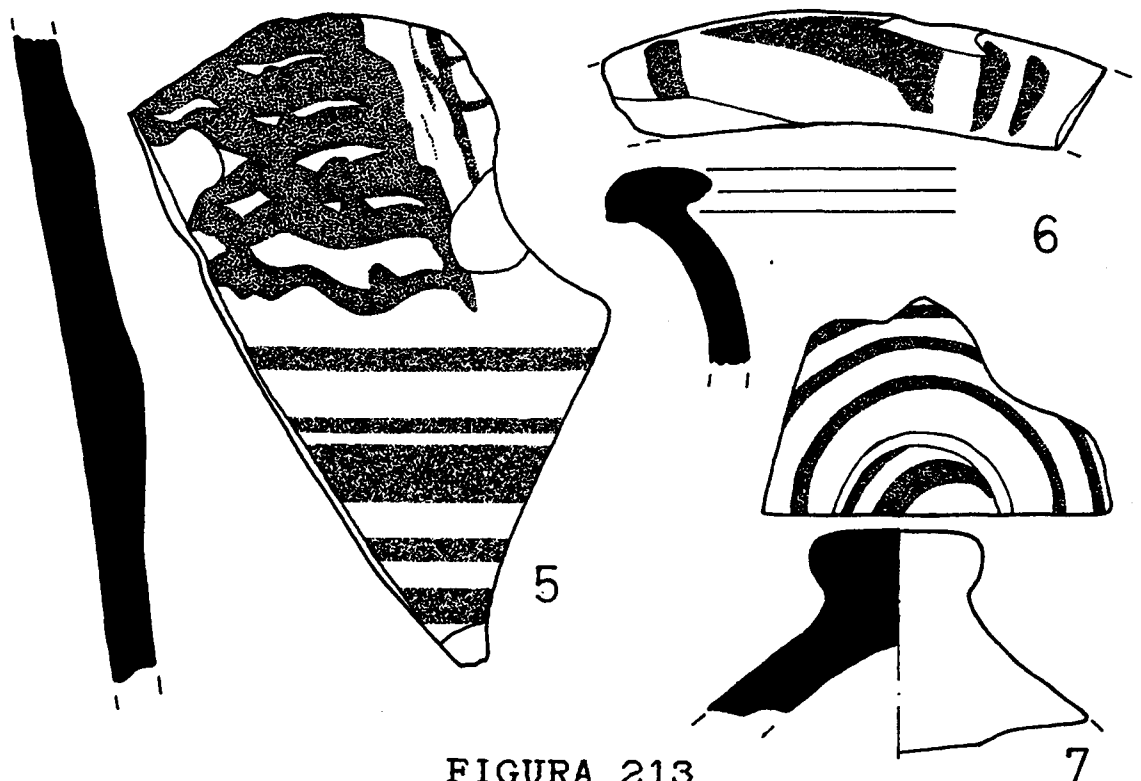
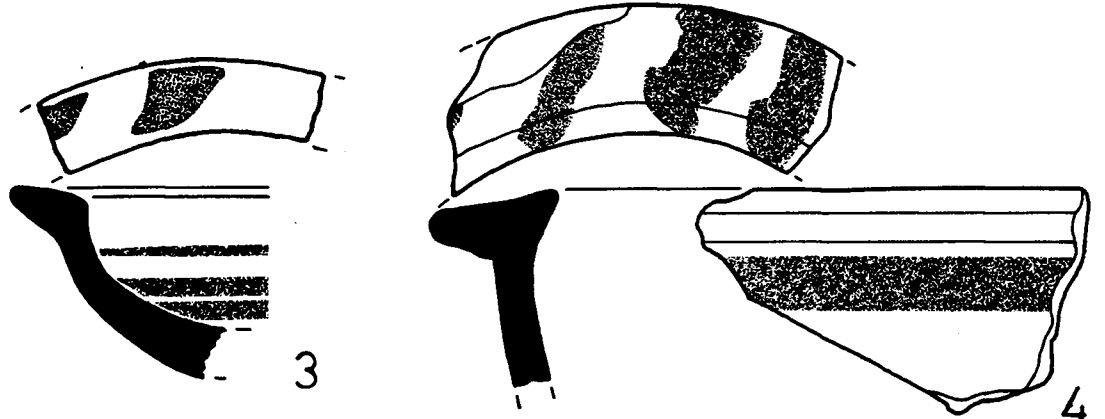
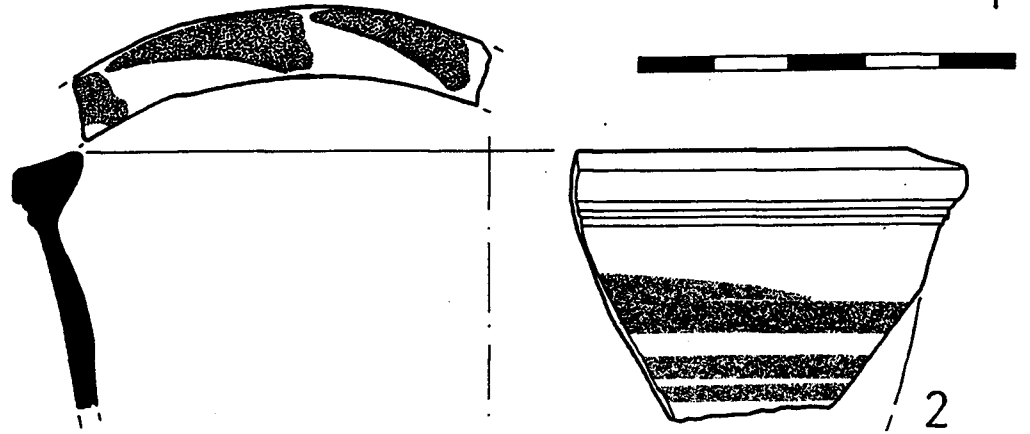
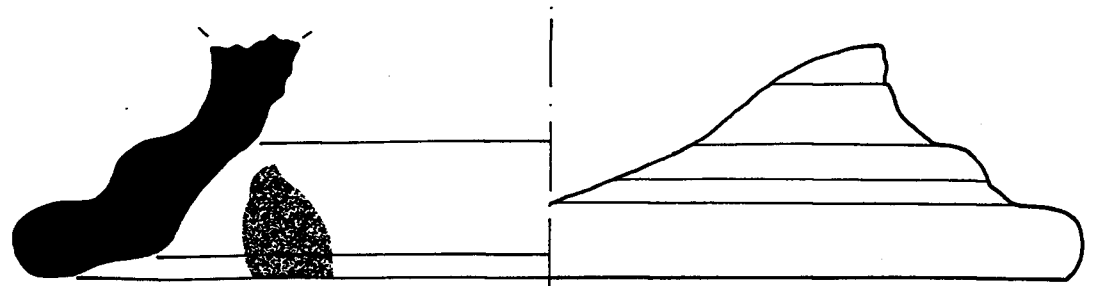

FIGURA 215

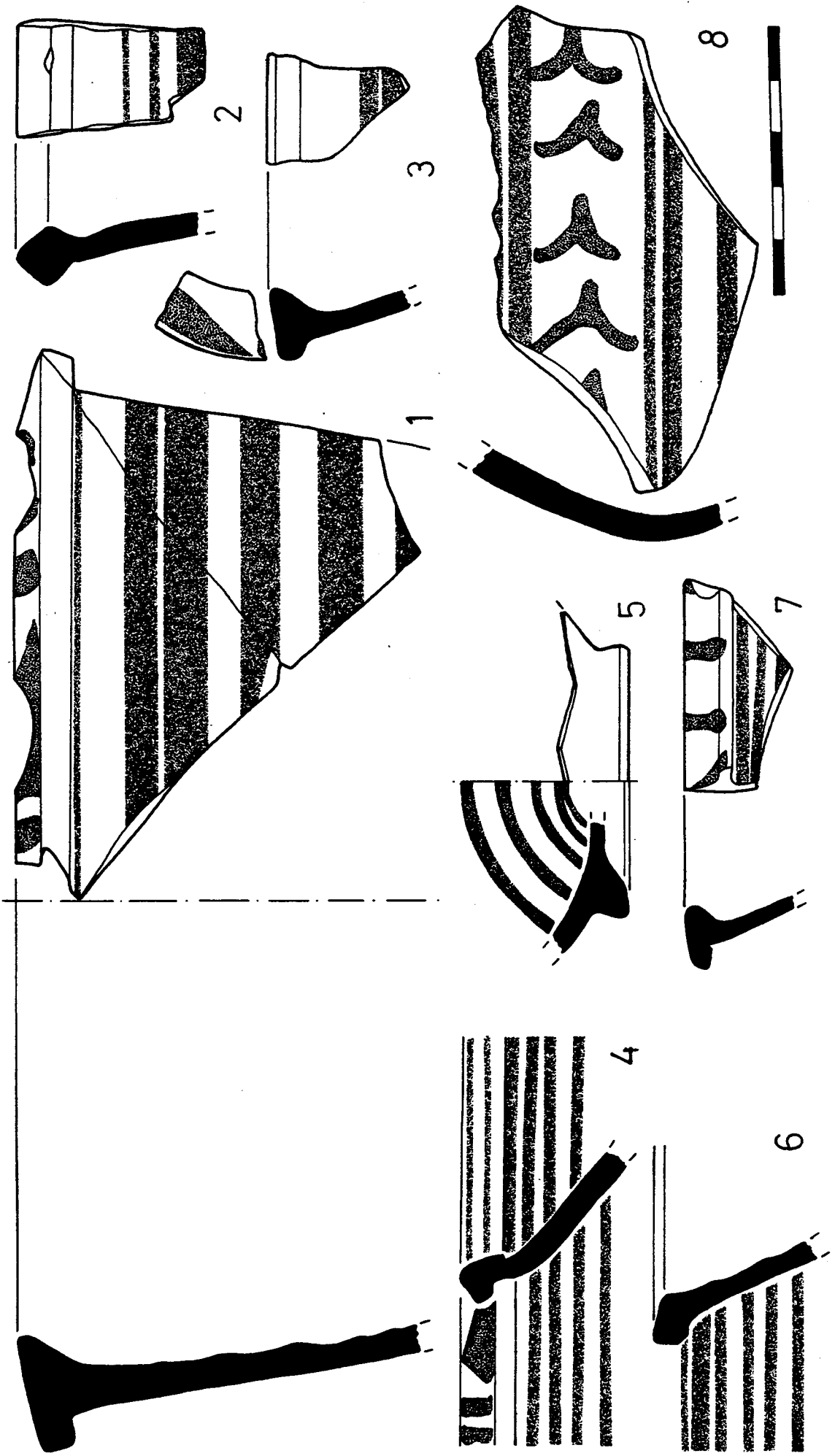

FIGURA 216

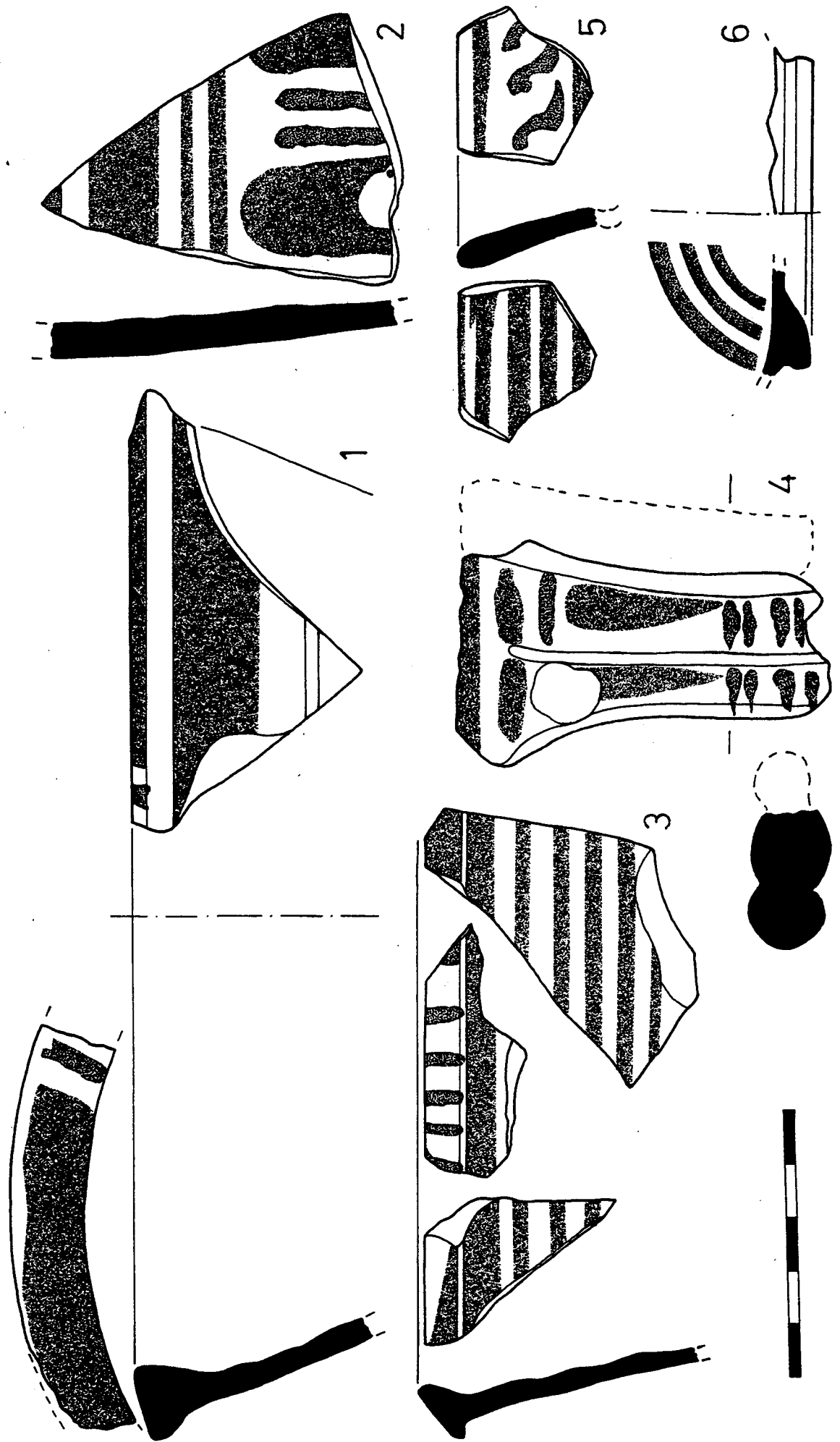

FIGURA 217

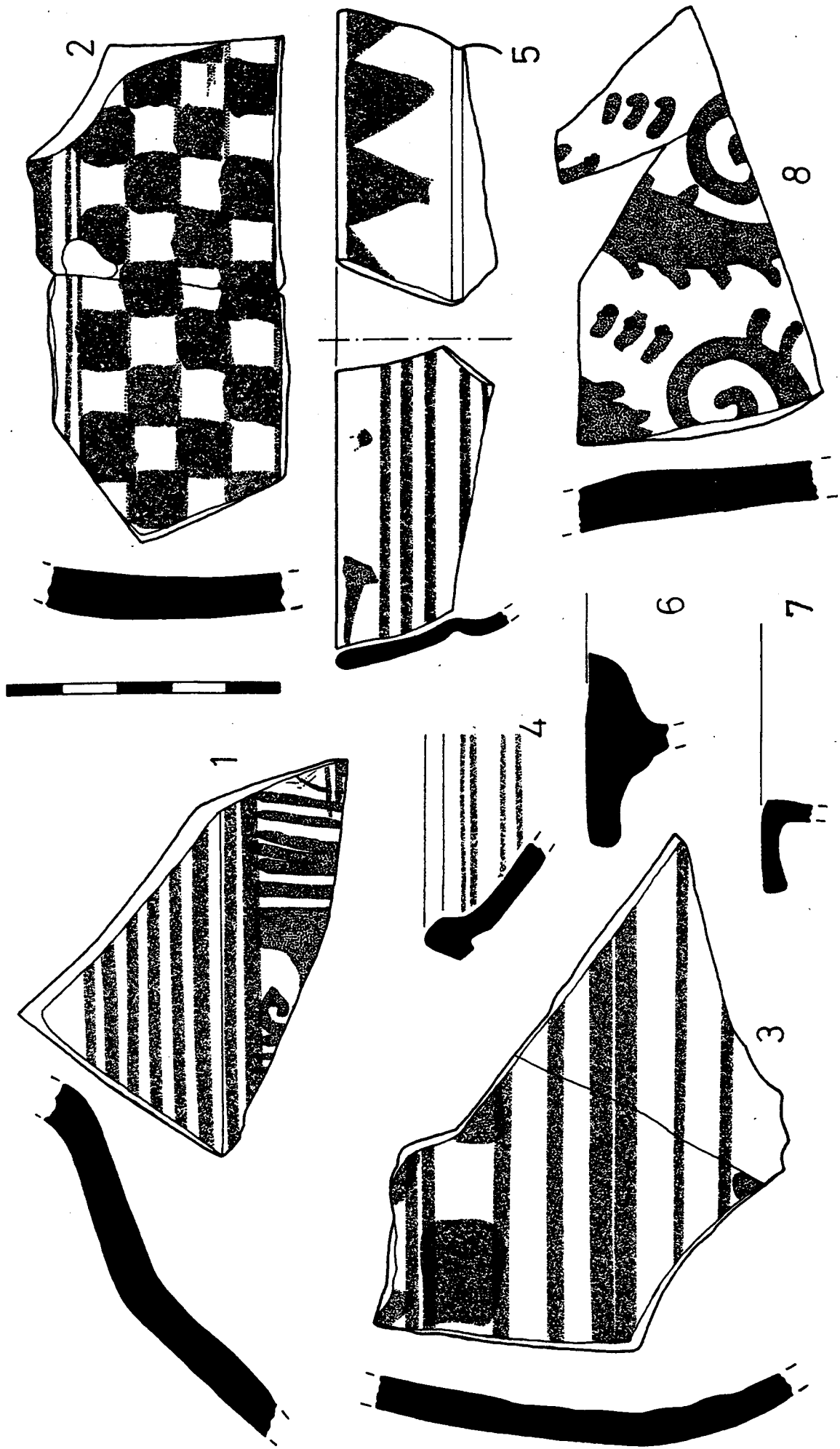

FIGURA 218



FIGURA 219

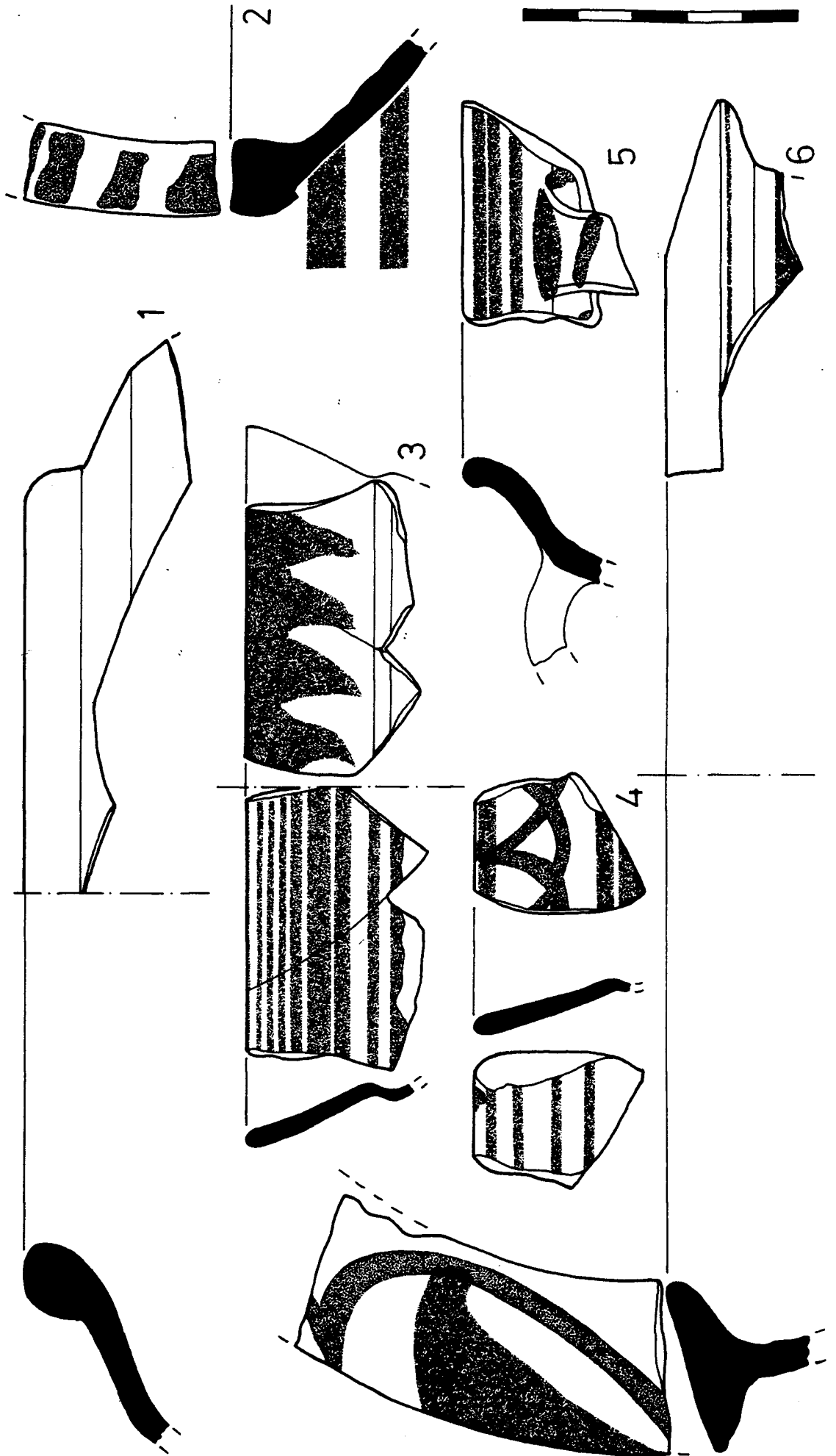

FIGURA 220

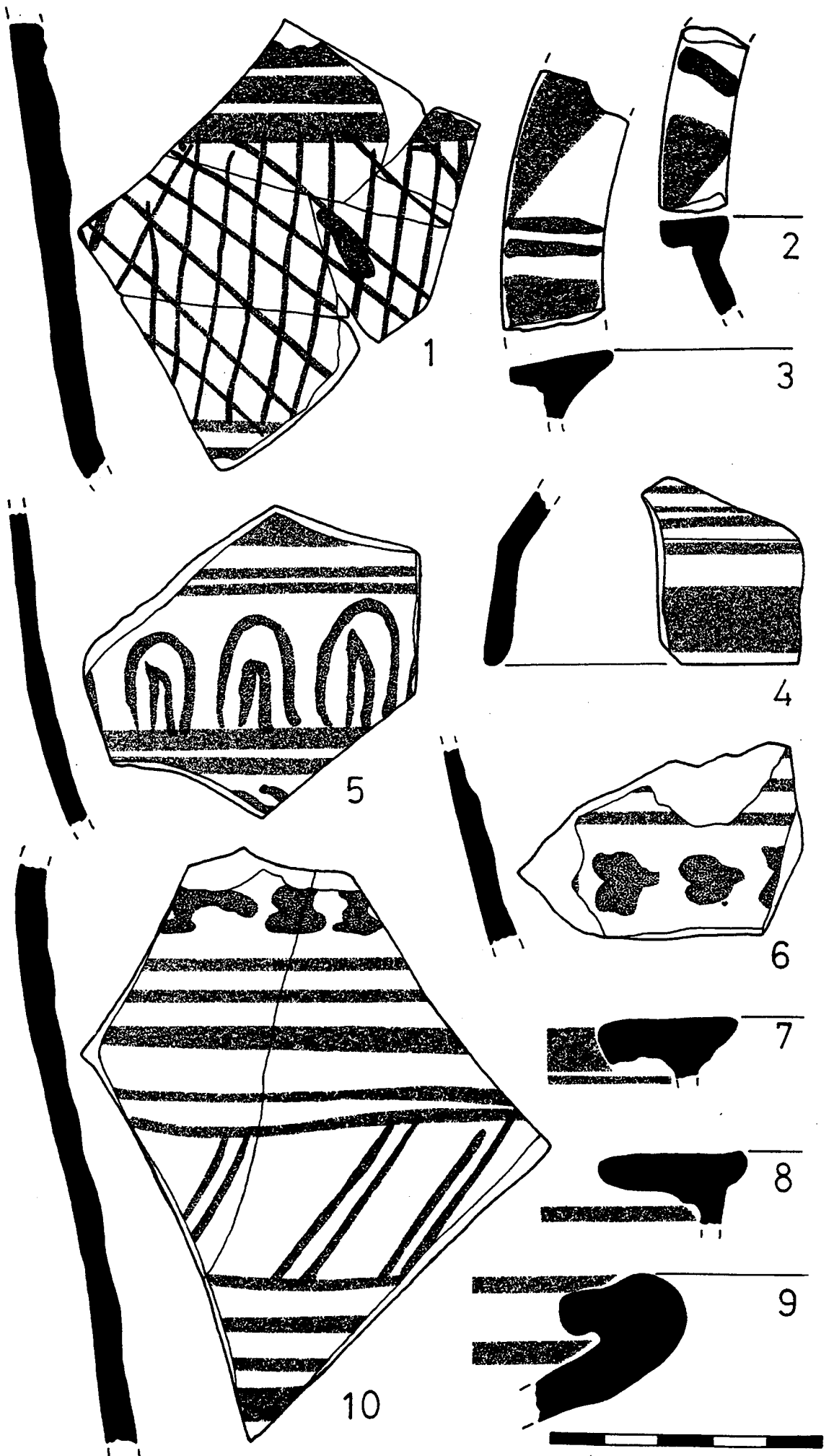

FIGURA 221

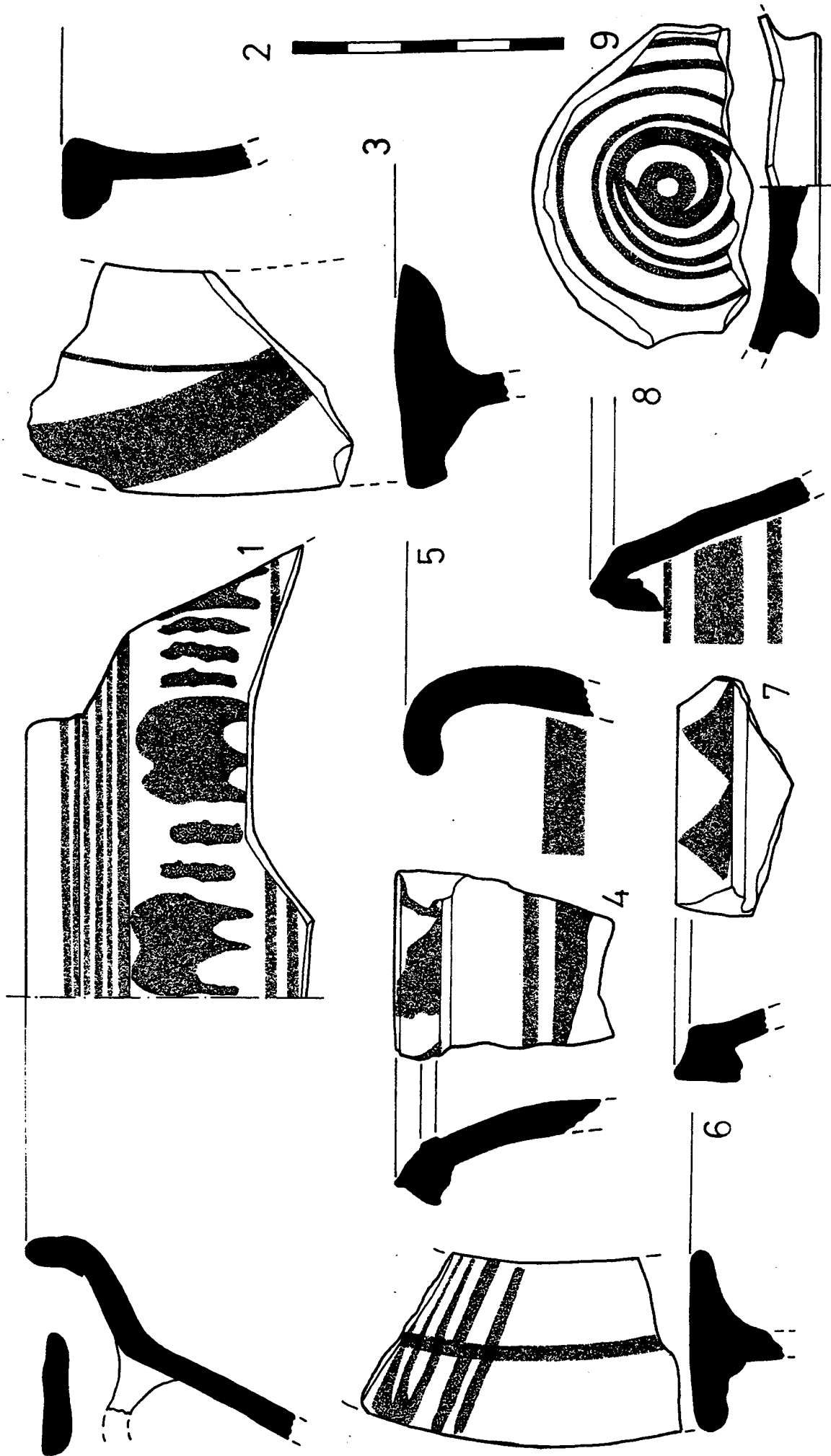

FIGURA 222

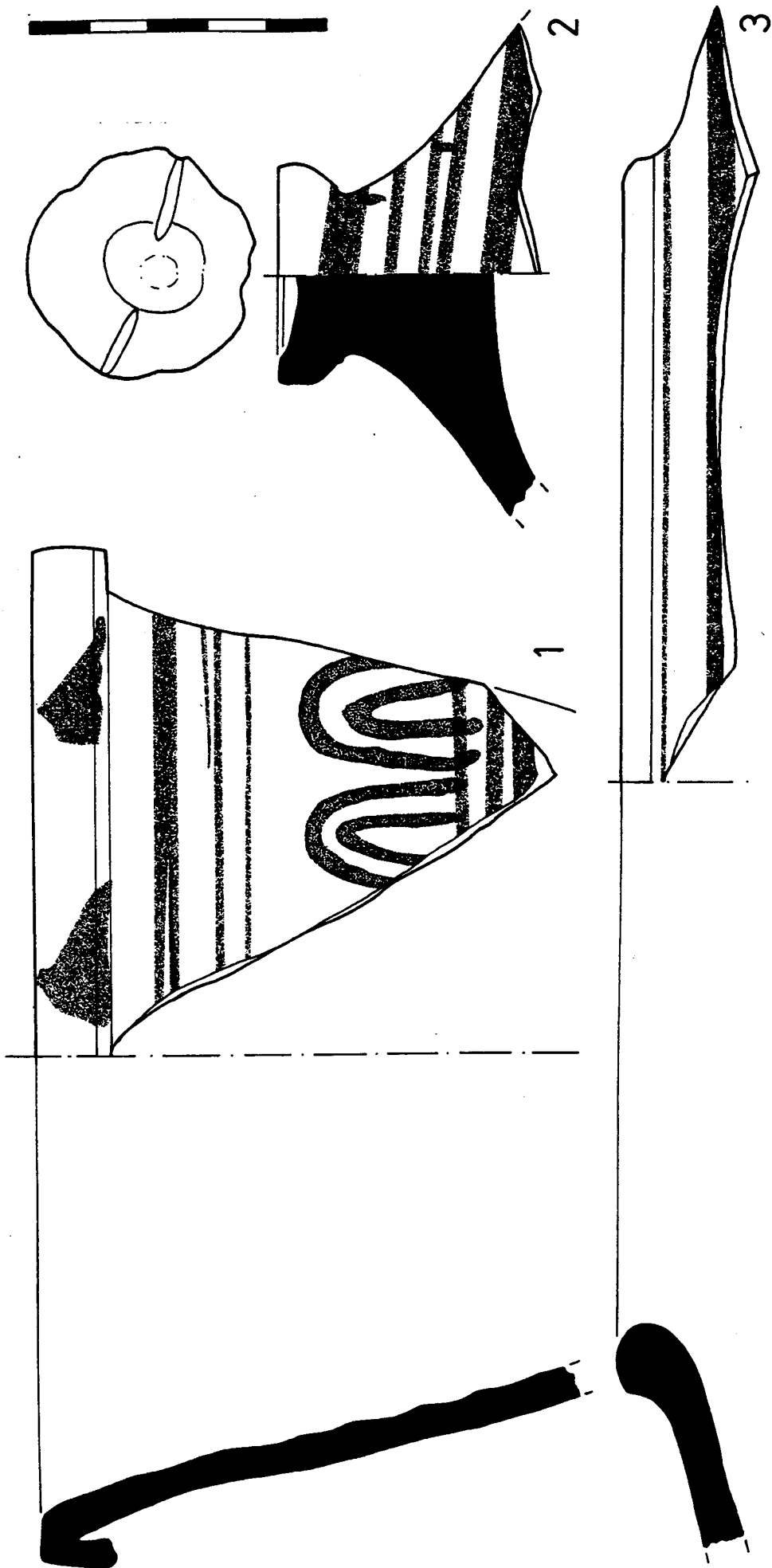

FIGURA 223

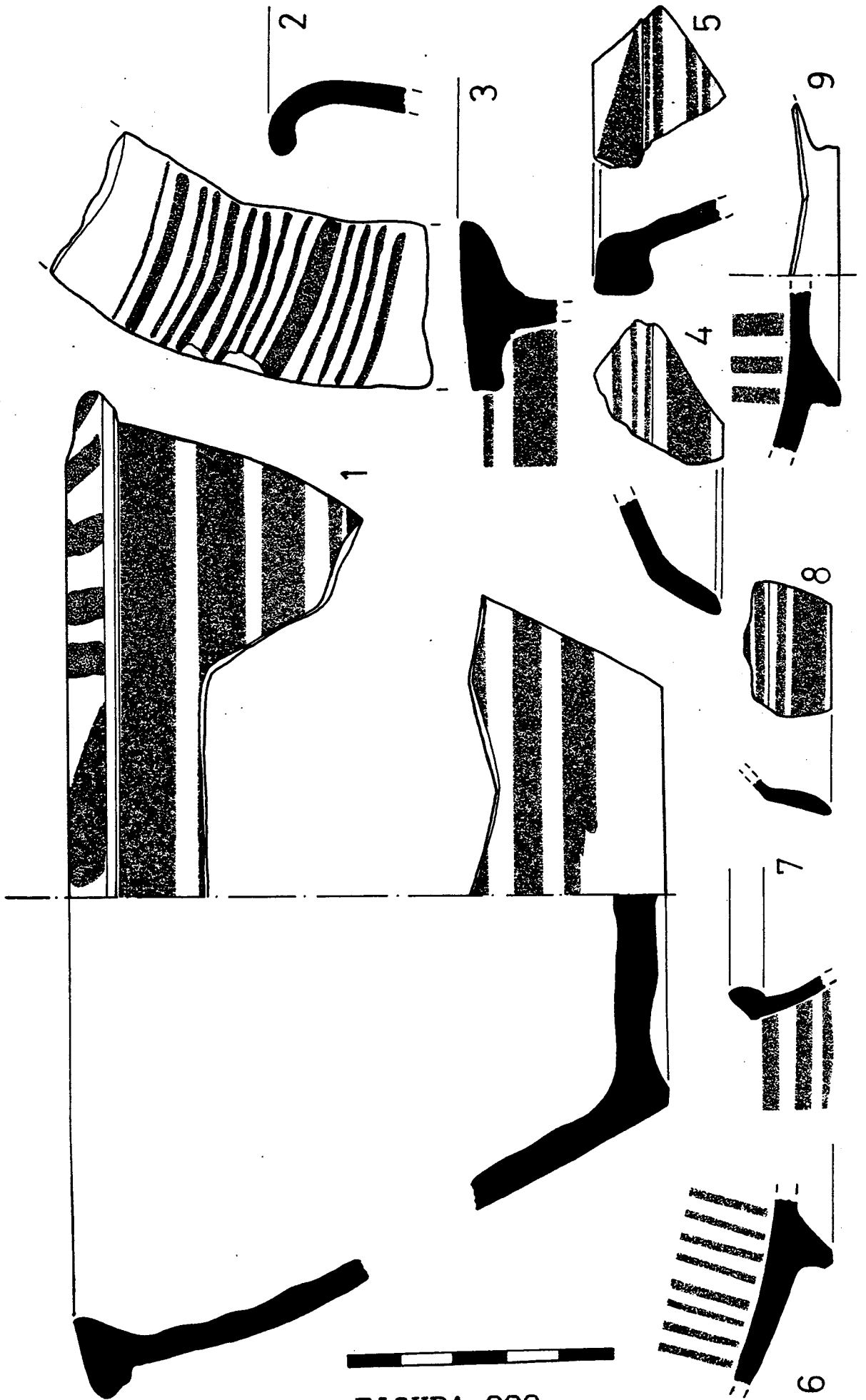

FIGURA 224

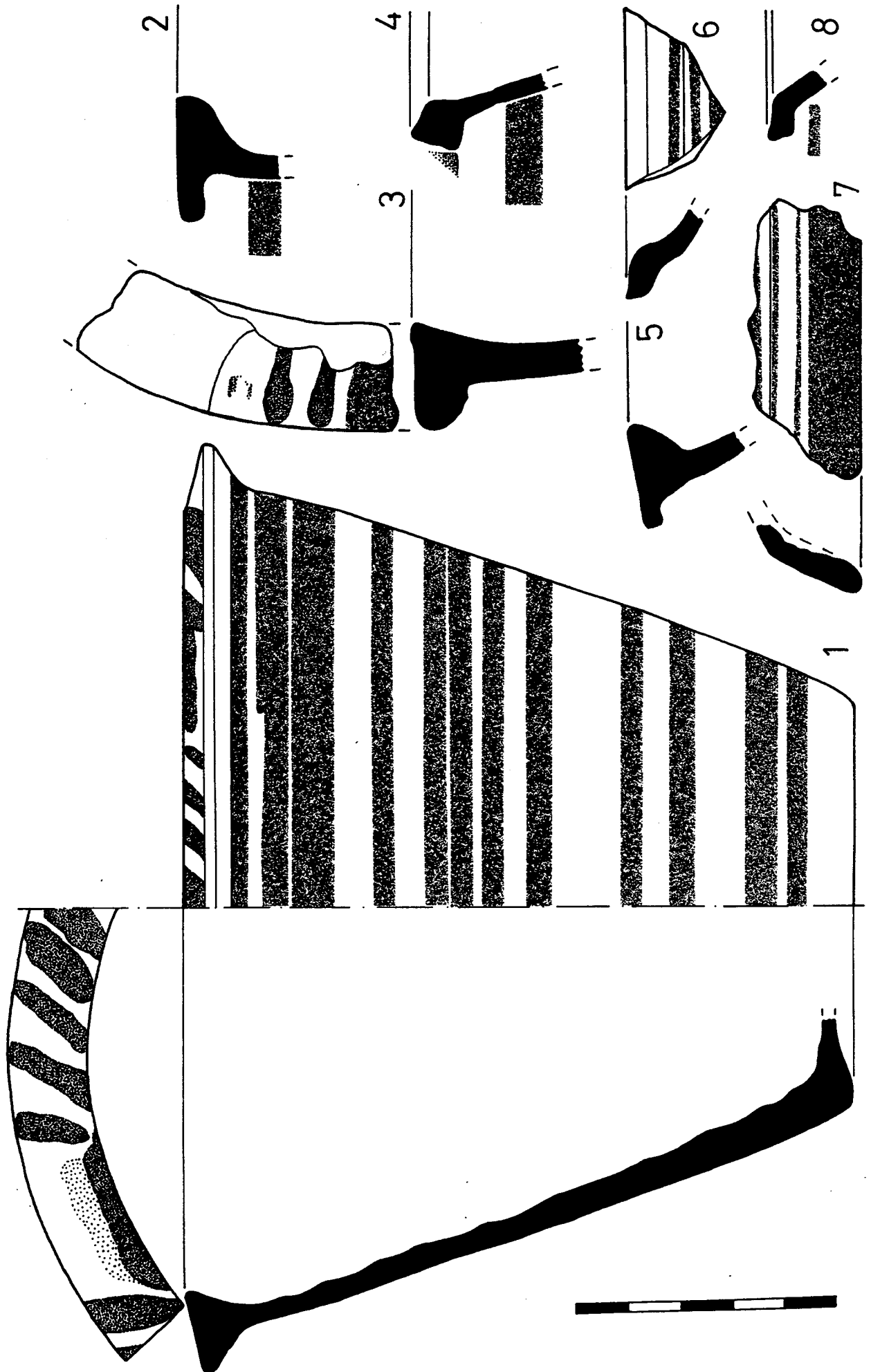

FIGURA 225

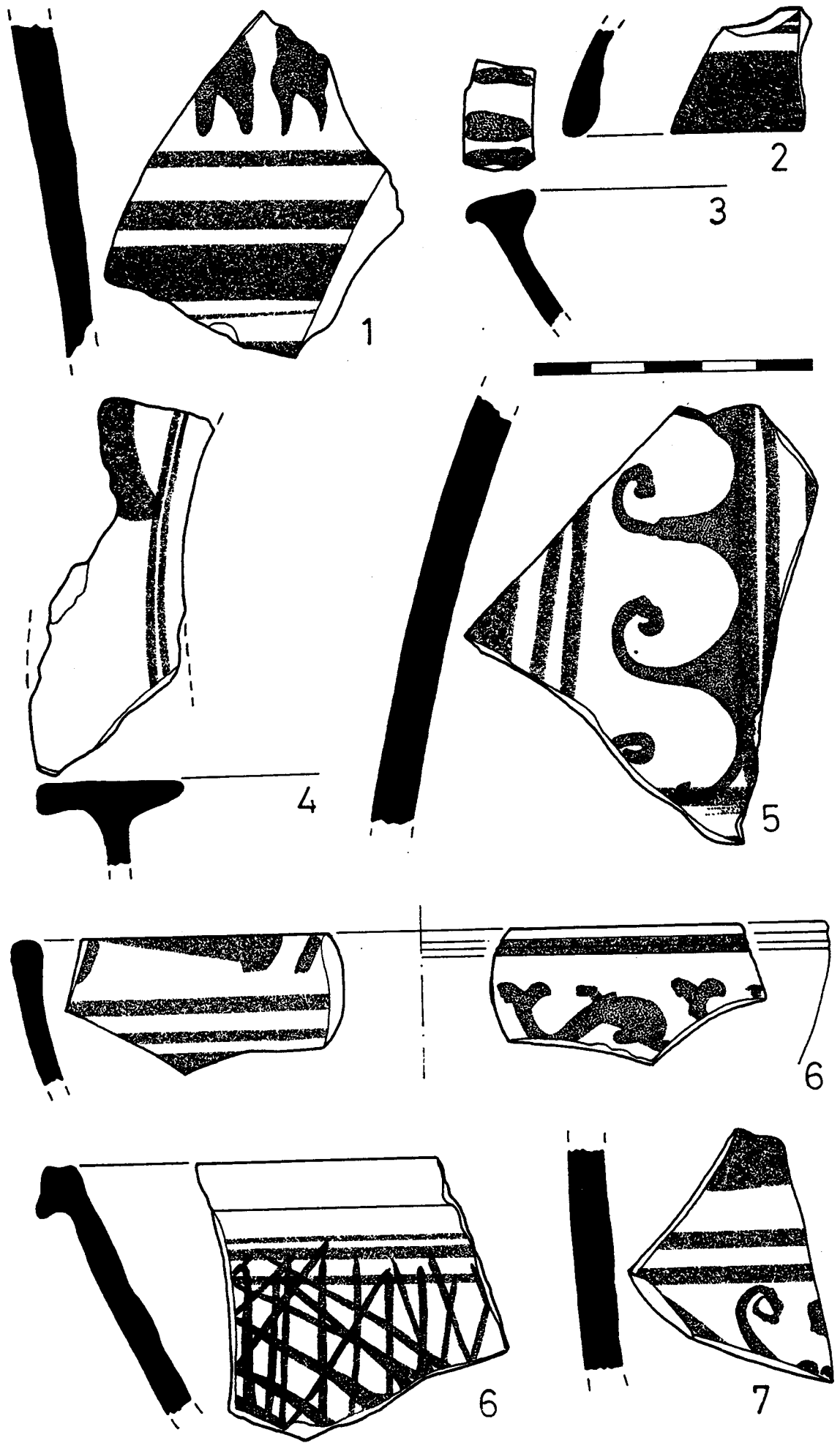

FIGURA 226

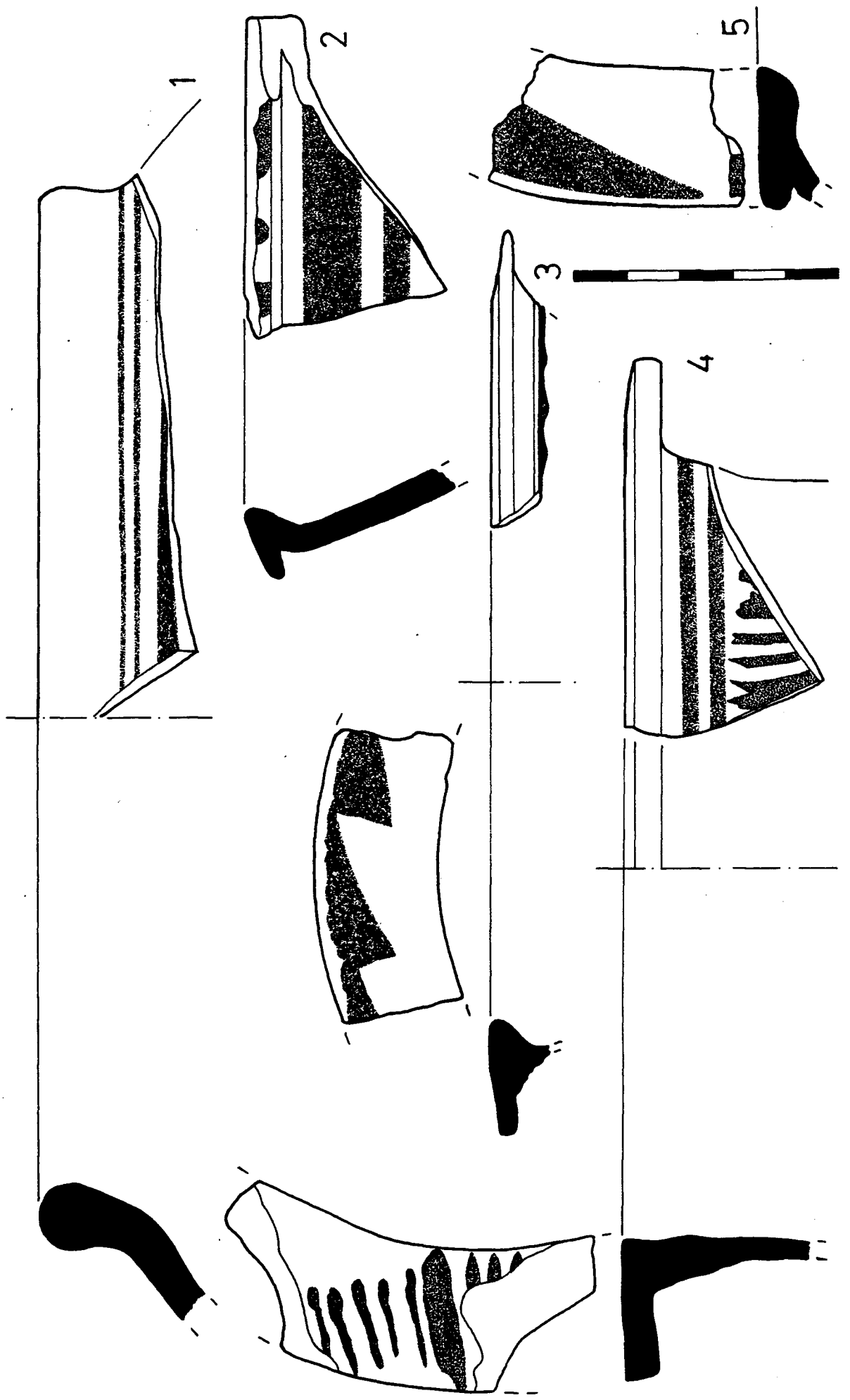

FIGURA 227

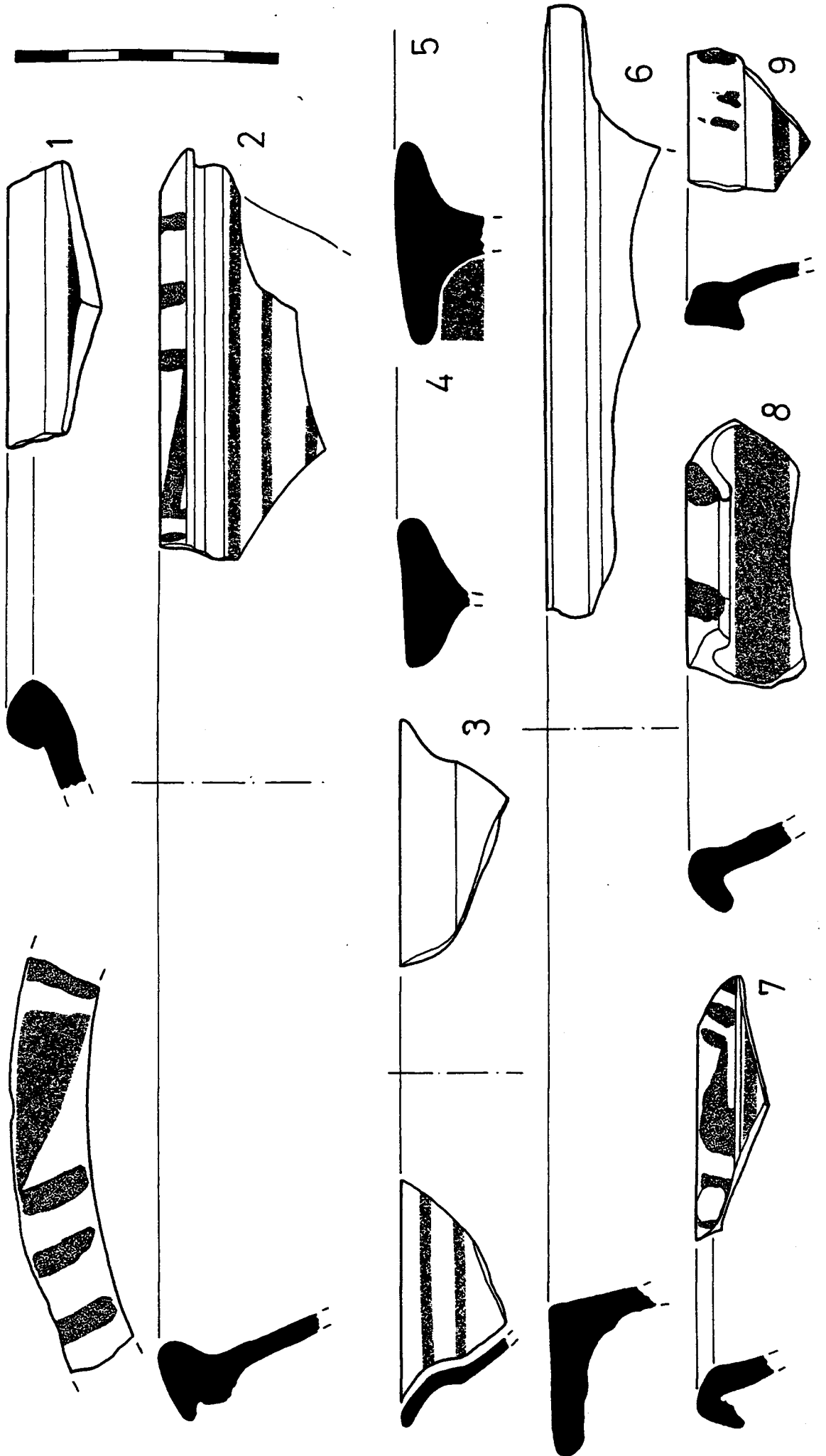

FIGURA 228

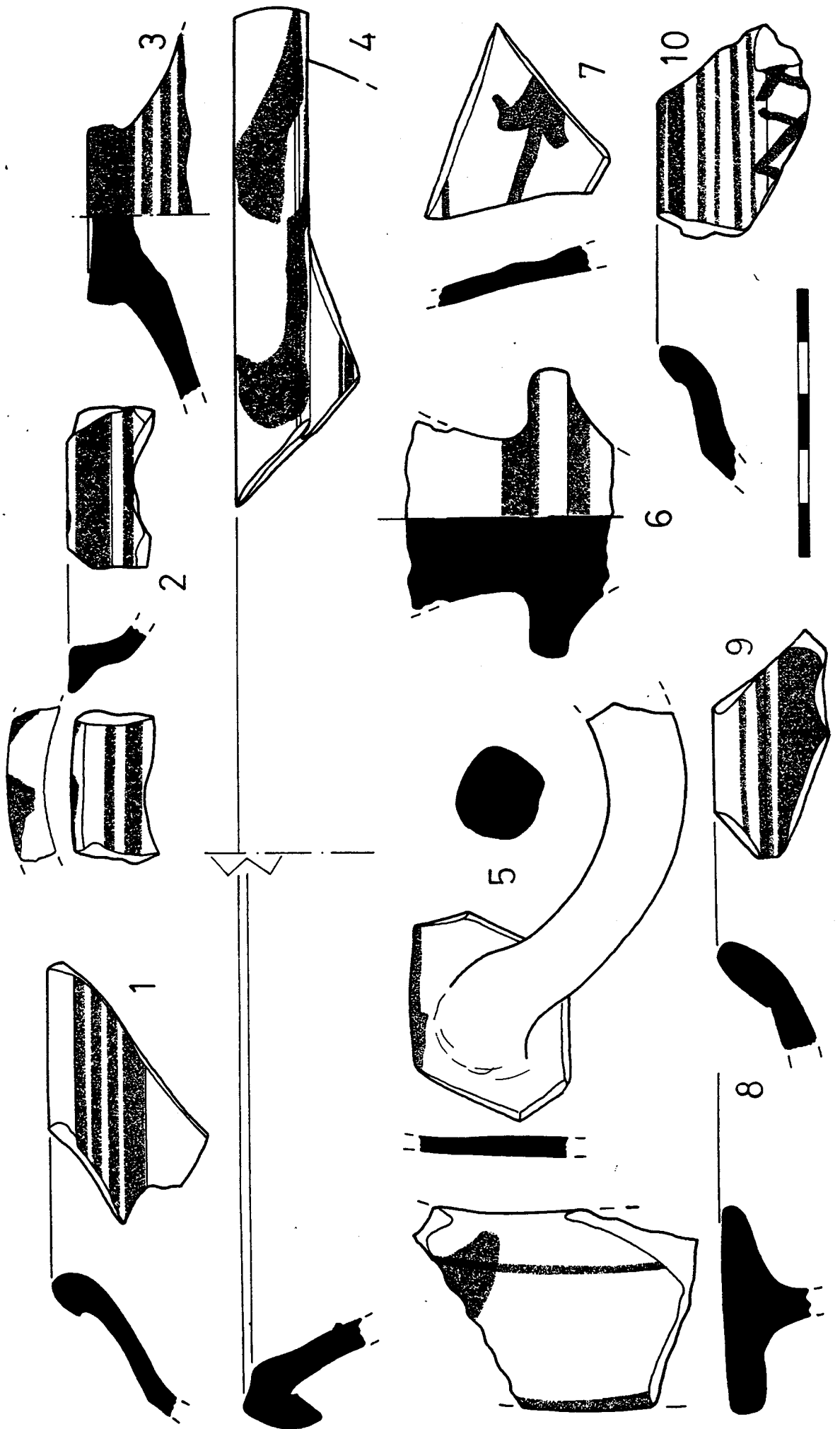

FIGURA 229

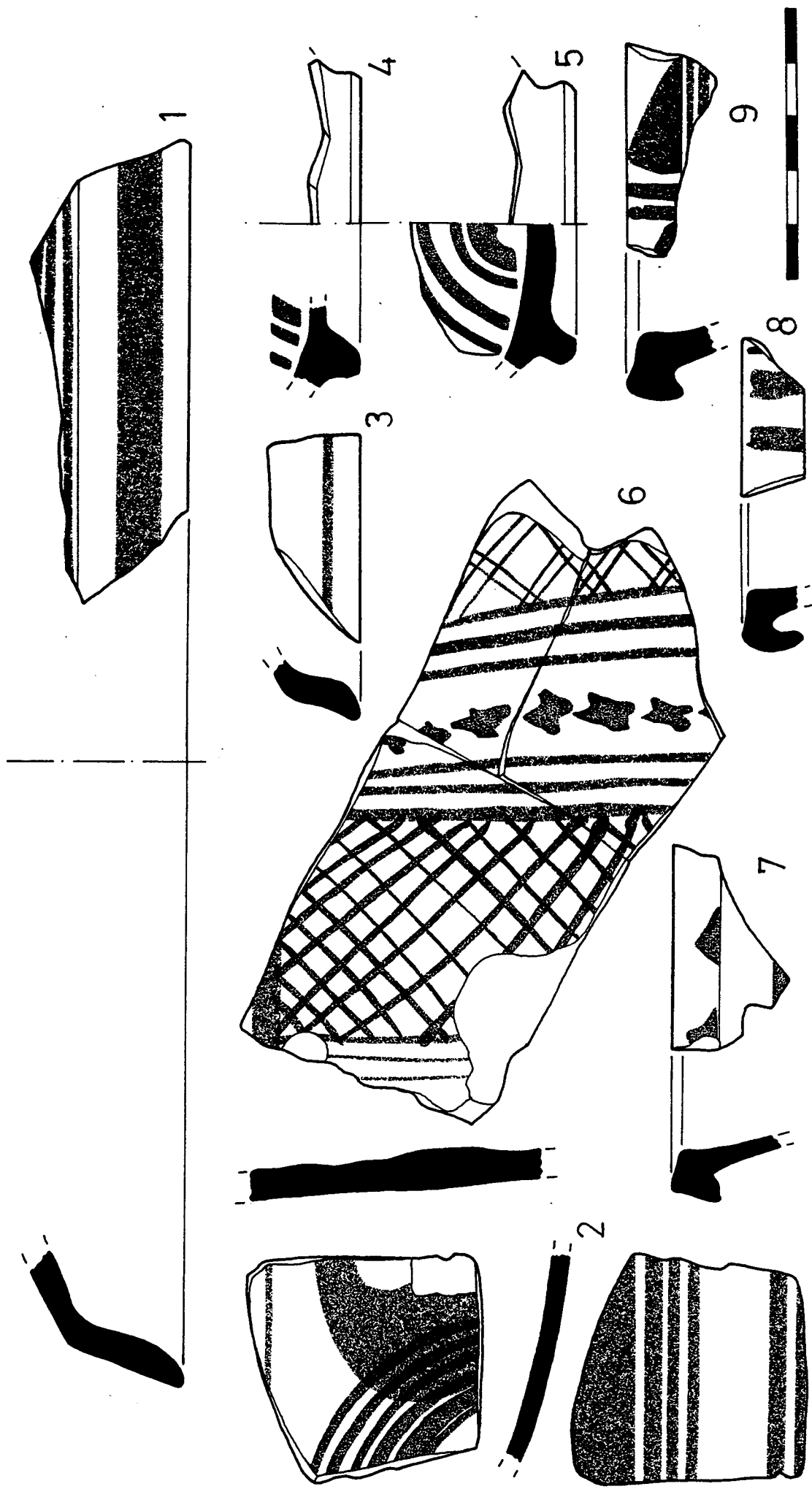

FIGURA 230

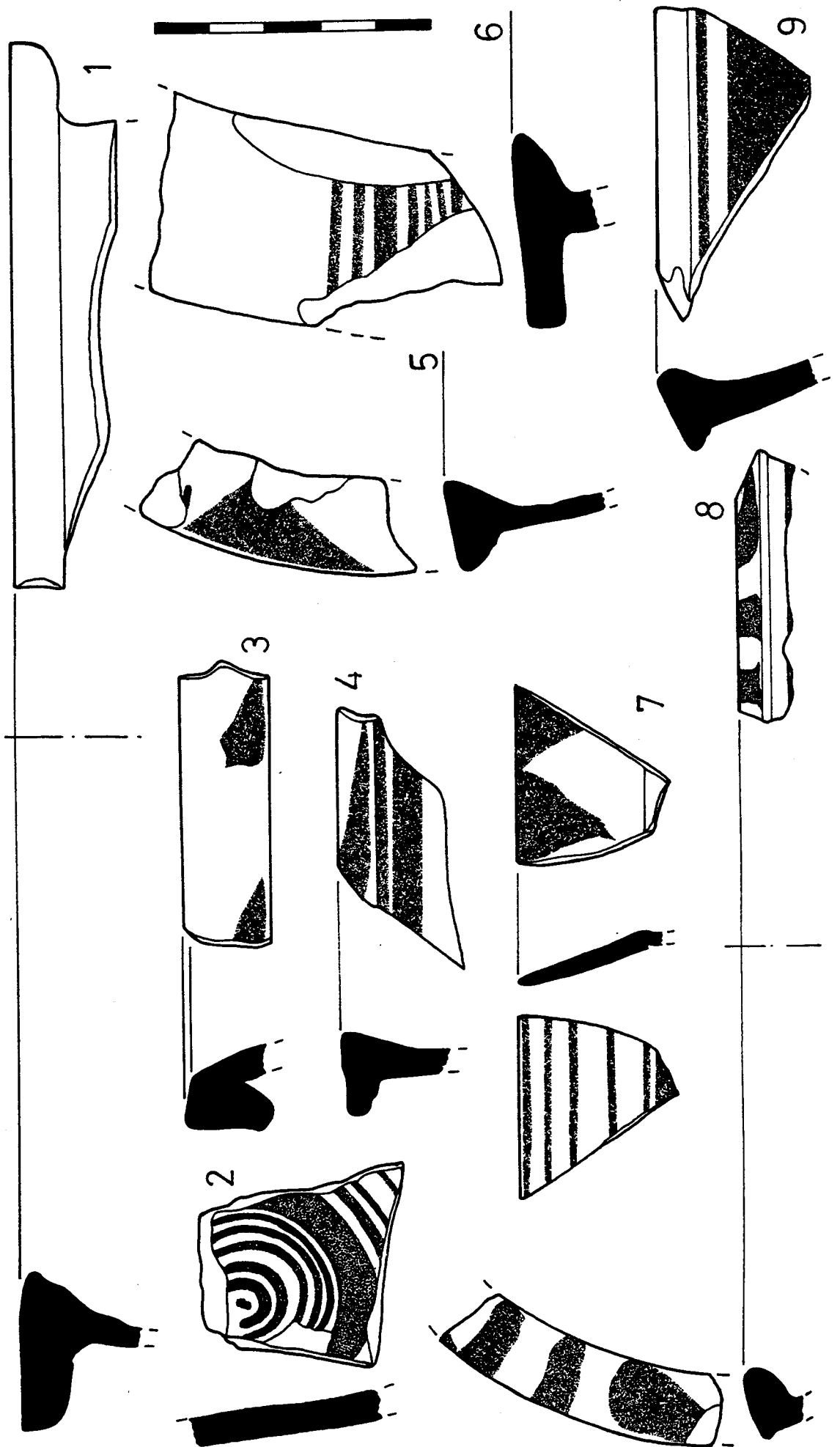

FIGURA 231

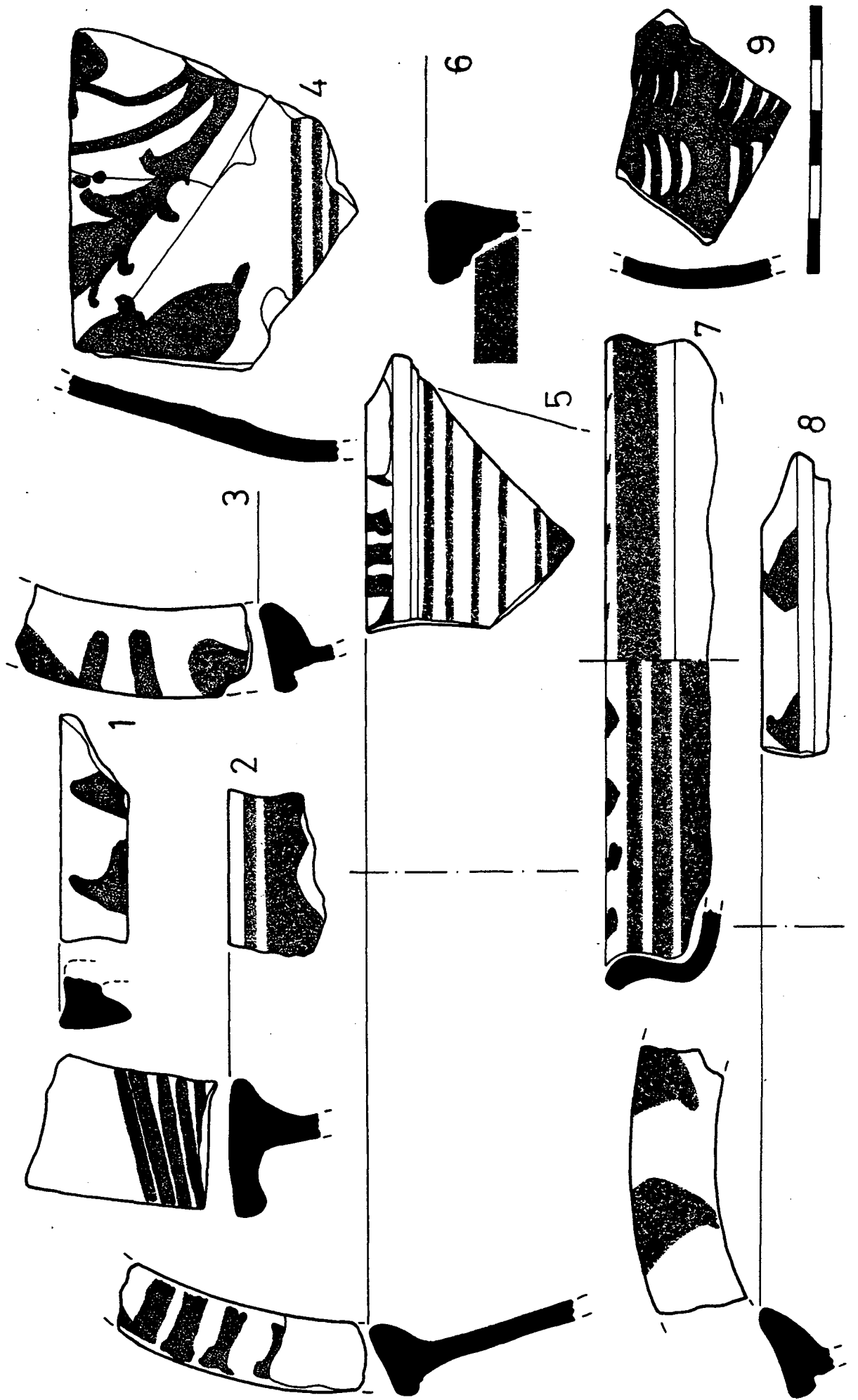

FIGURA 232

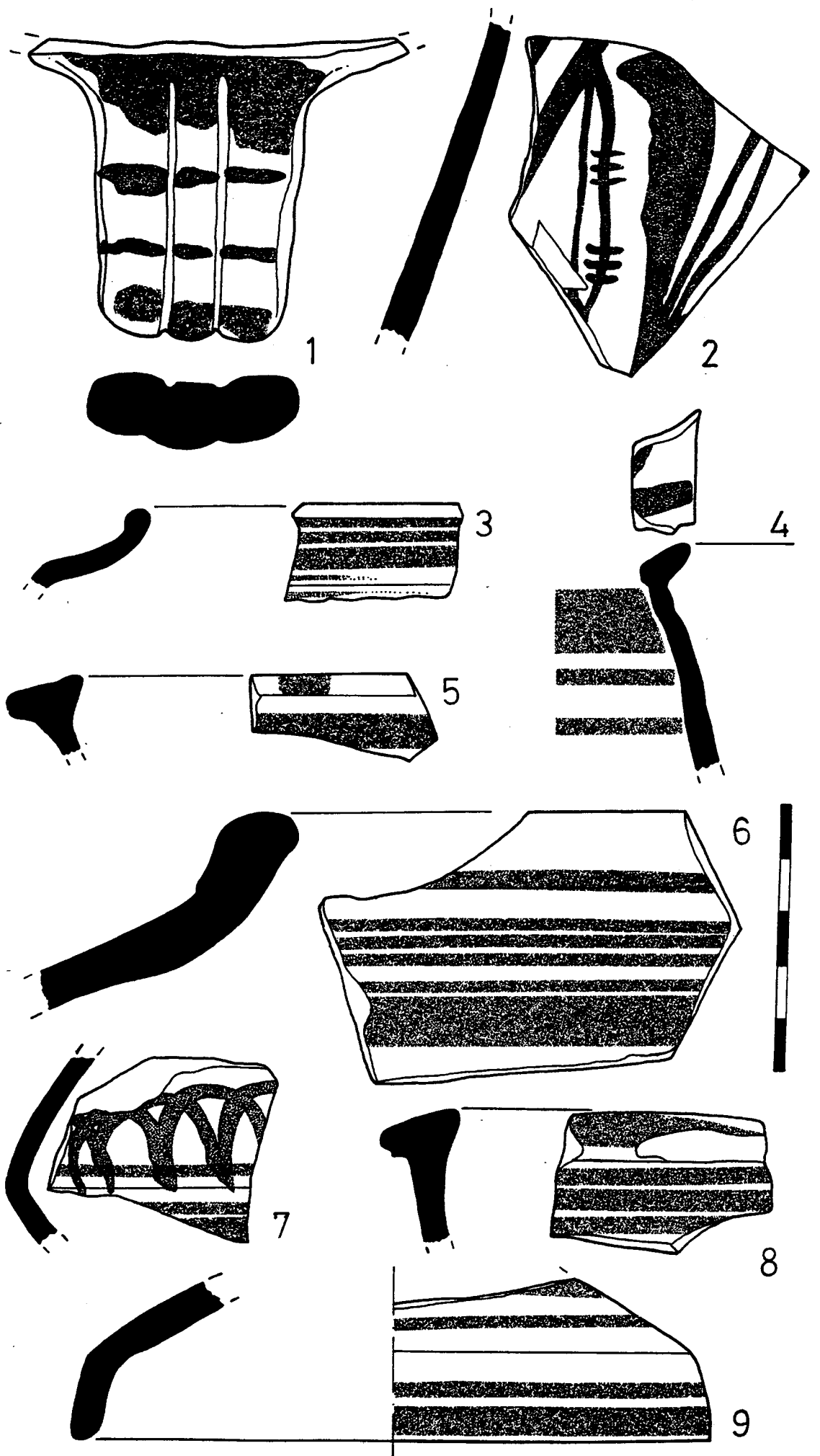

FIGURA 233

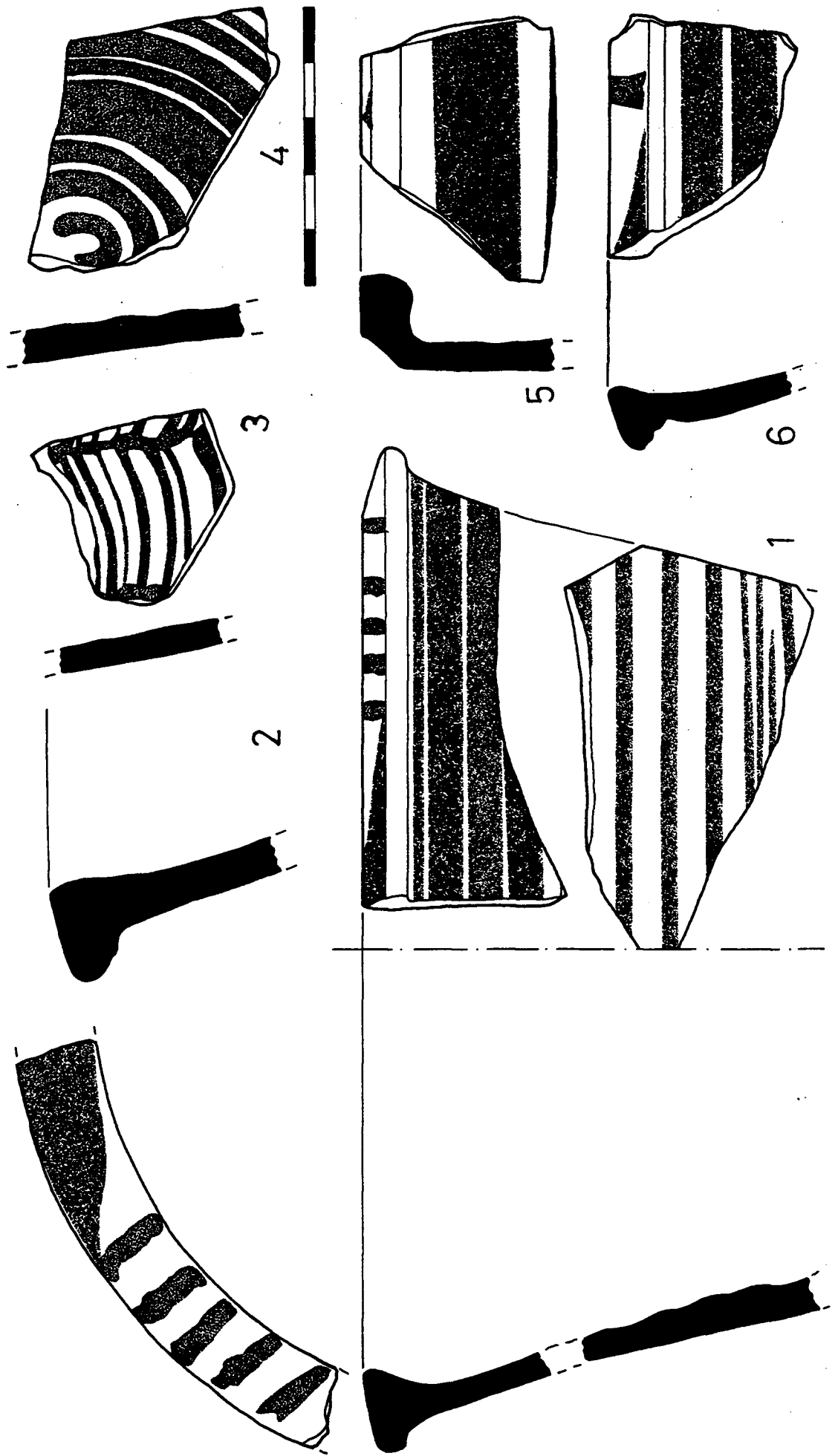

FIGURA 234

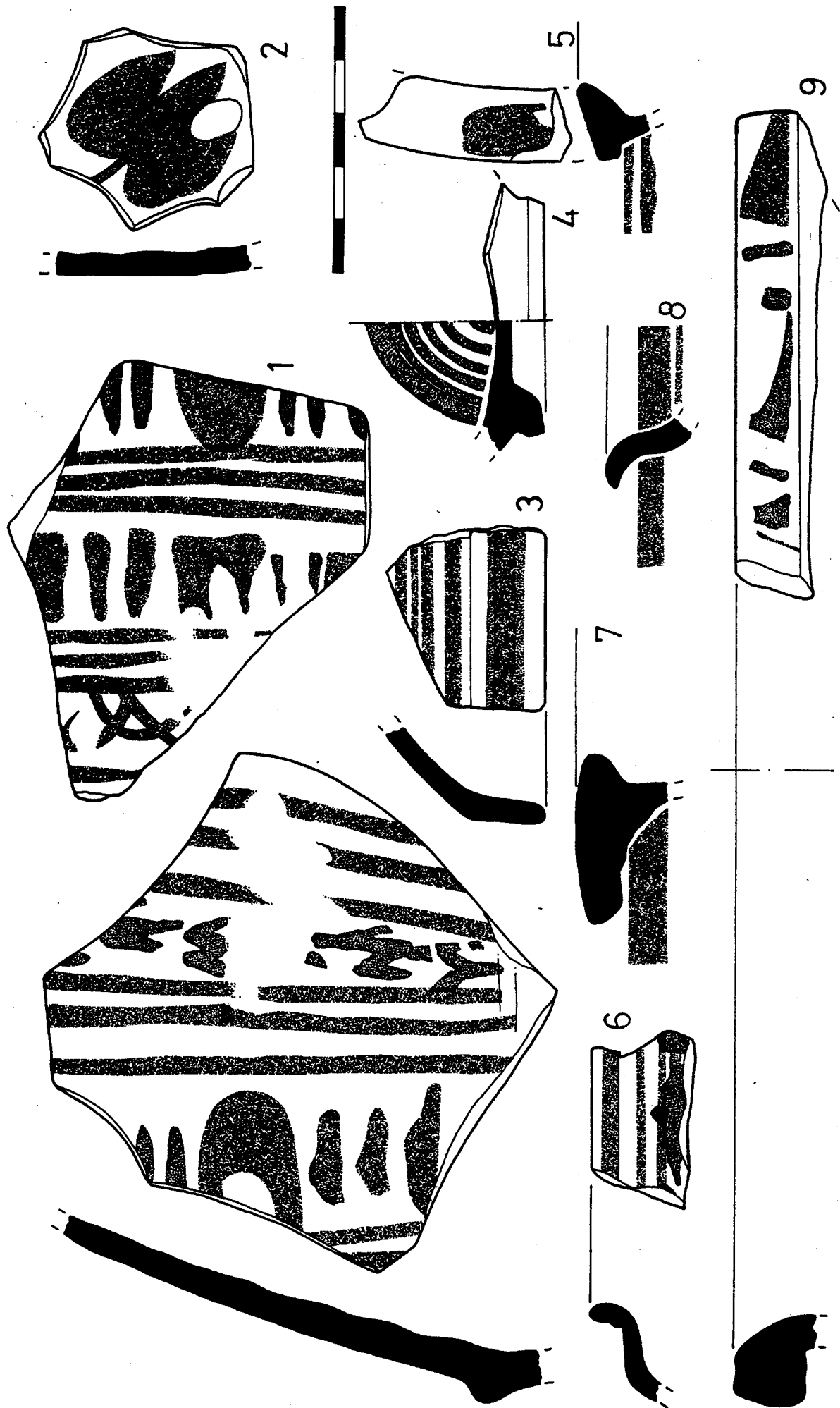

FIGURA 235

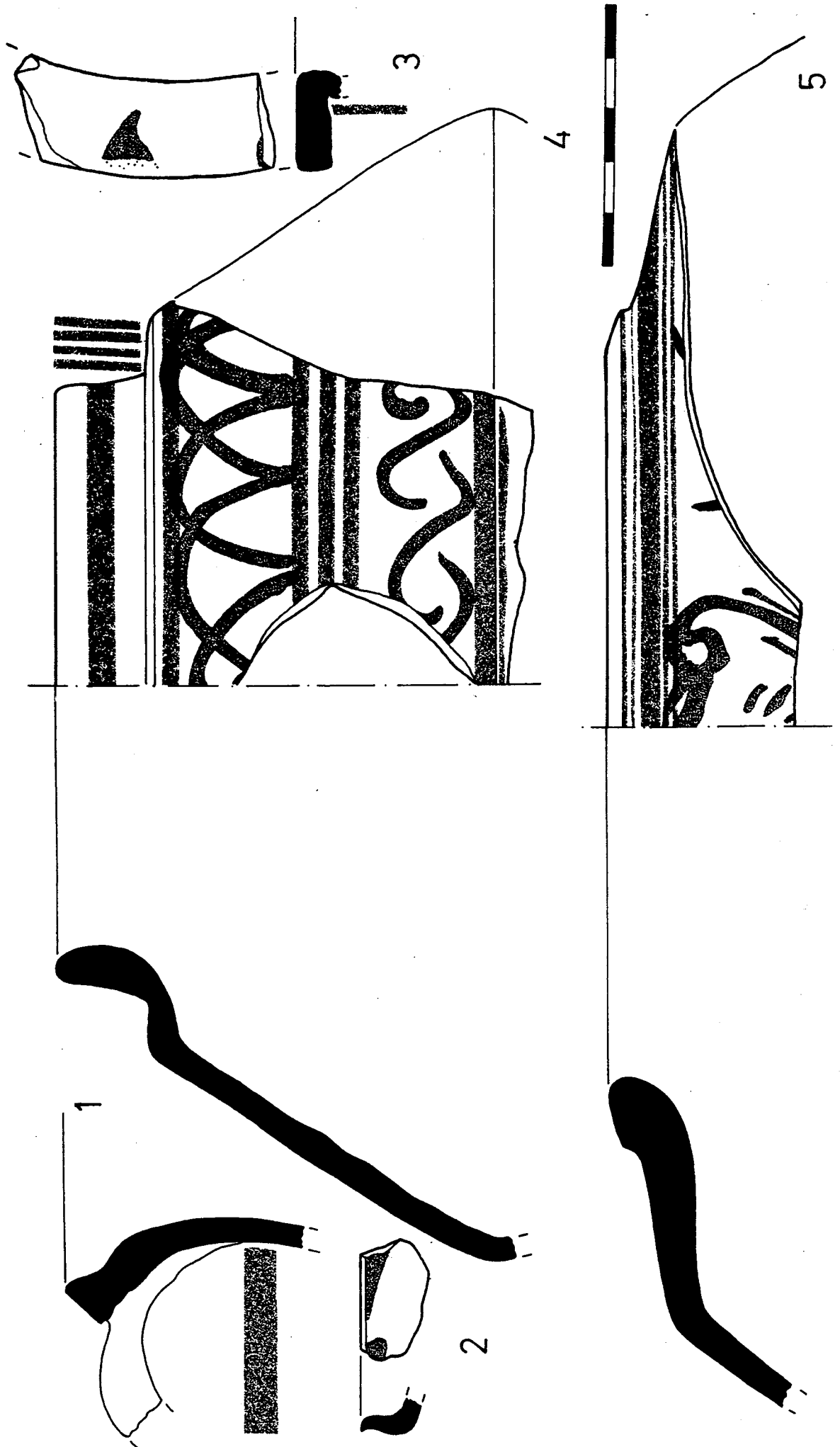

FIGURA 236

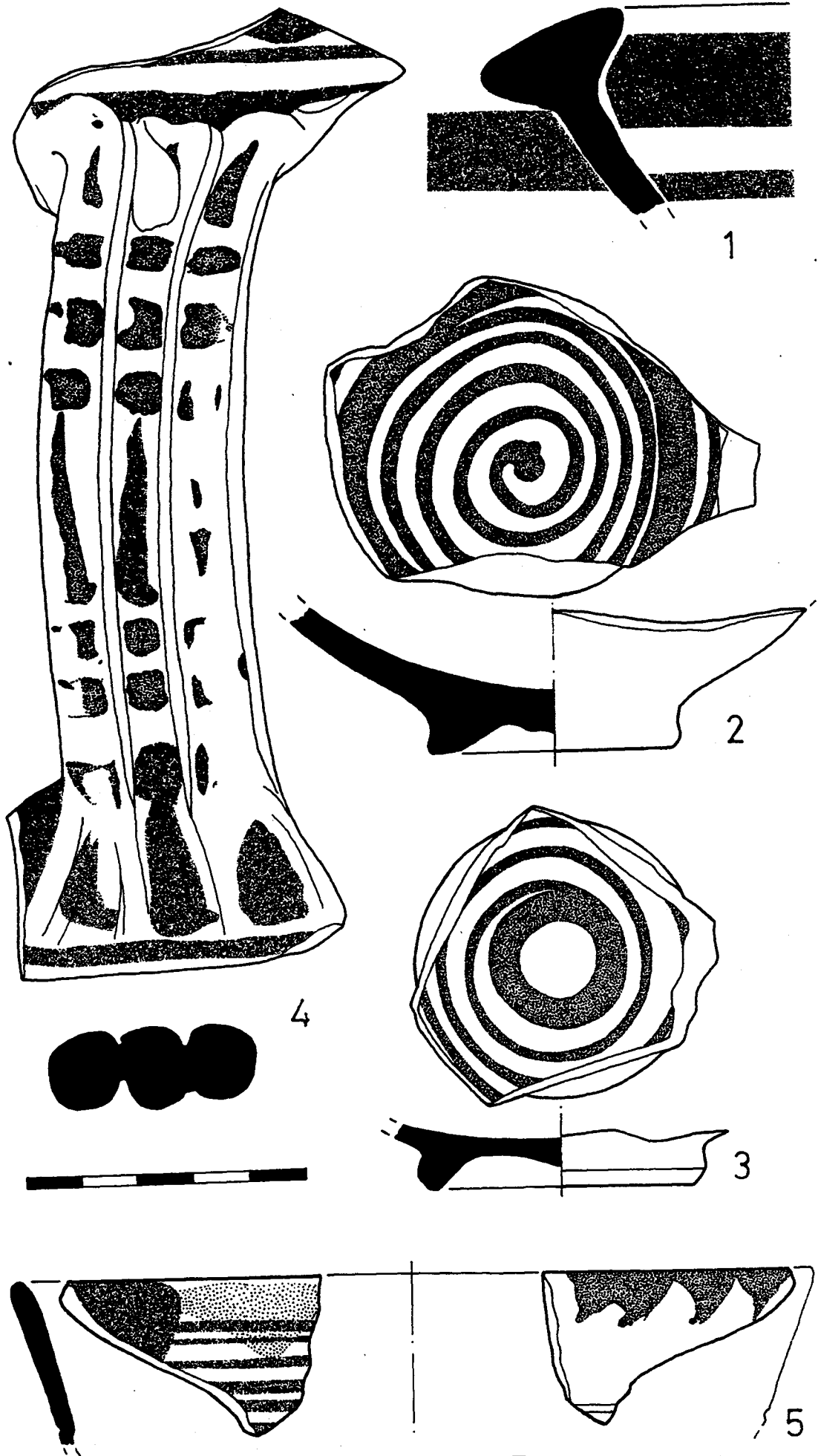

FIGURA 237

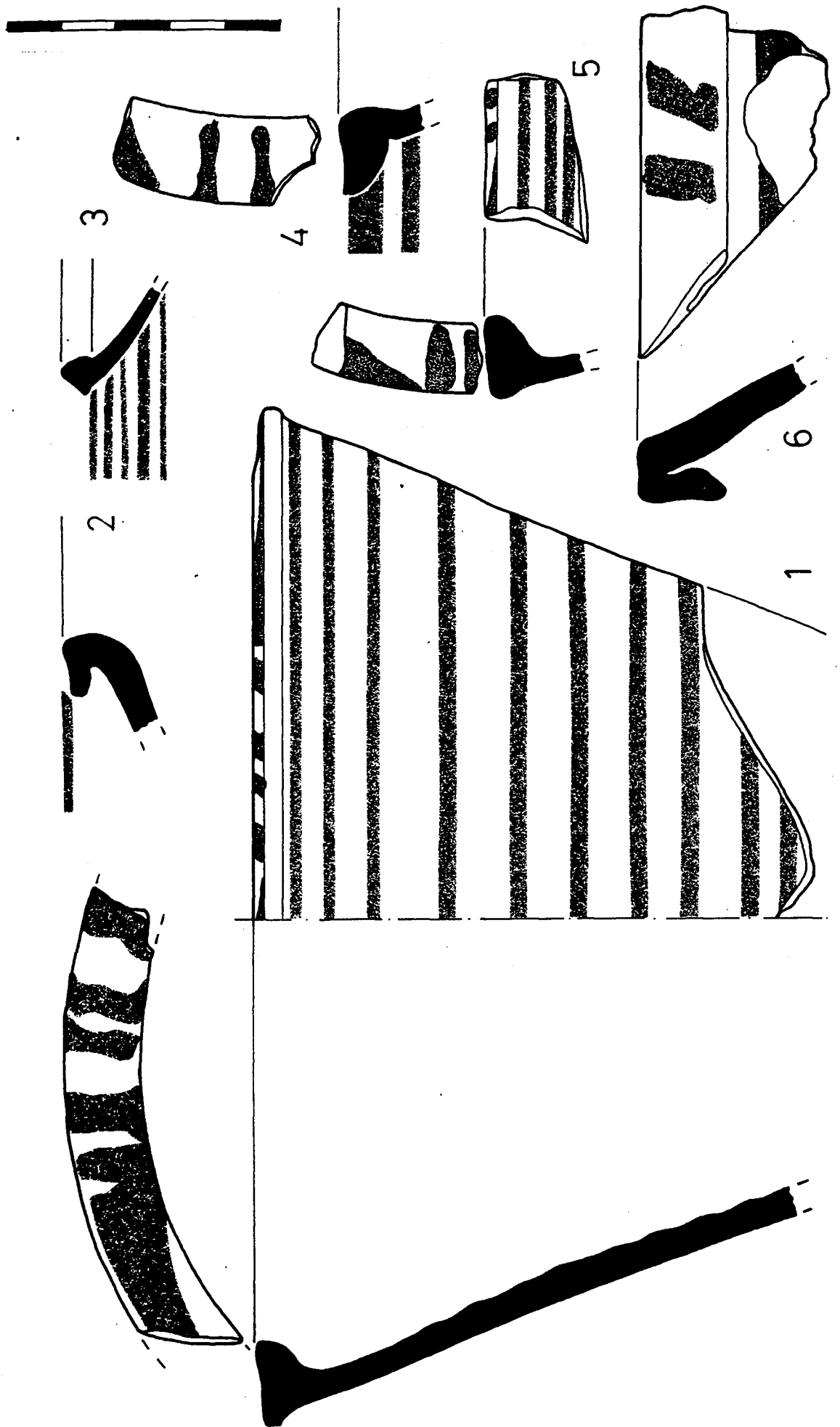

1

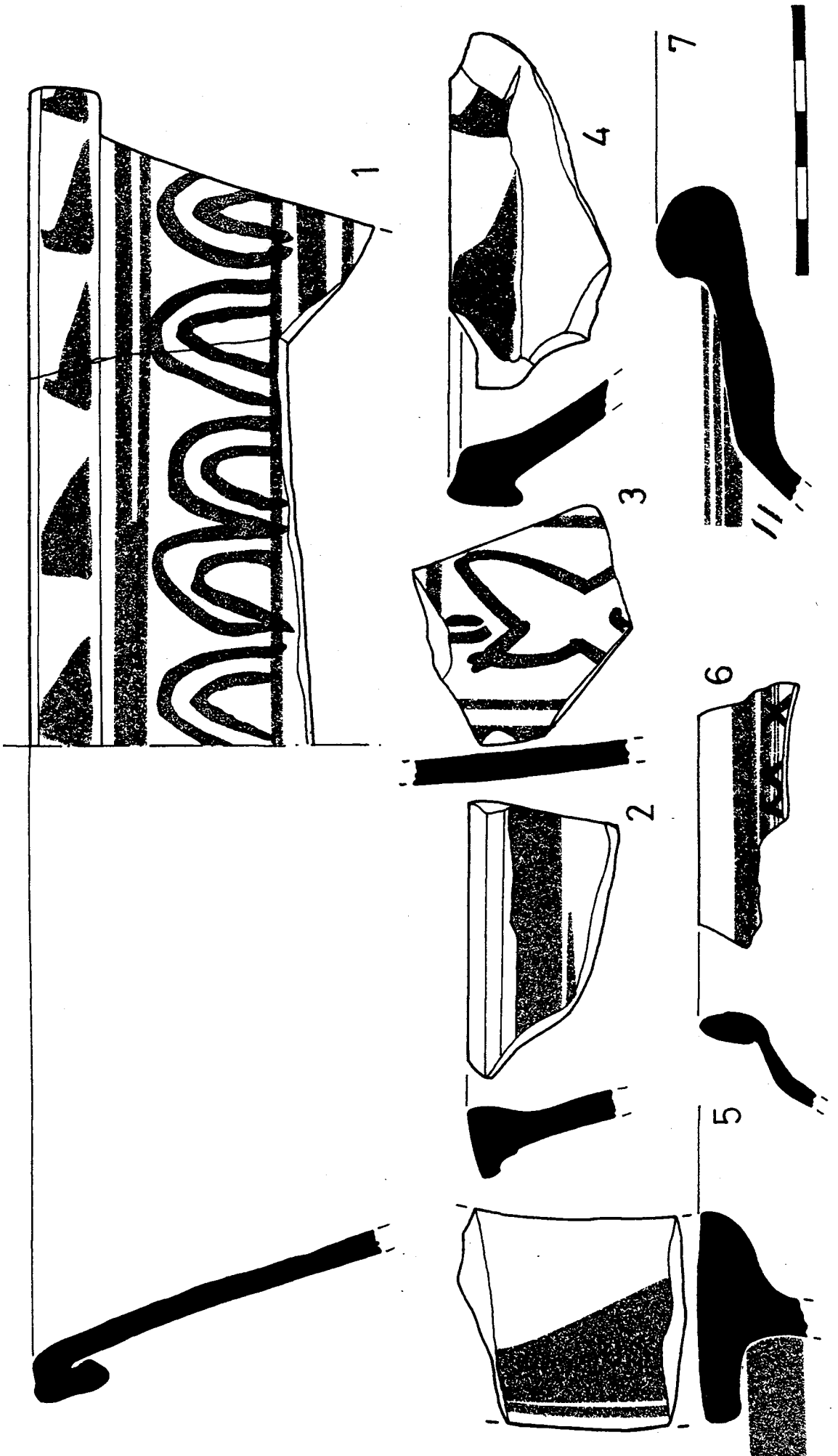
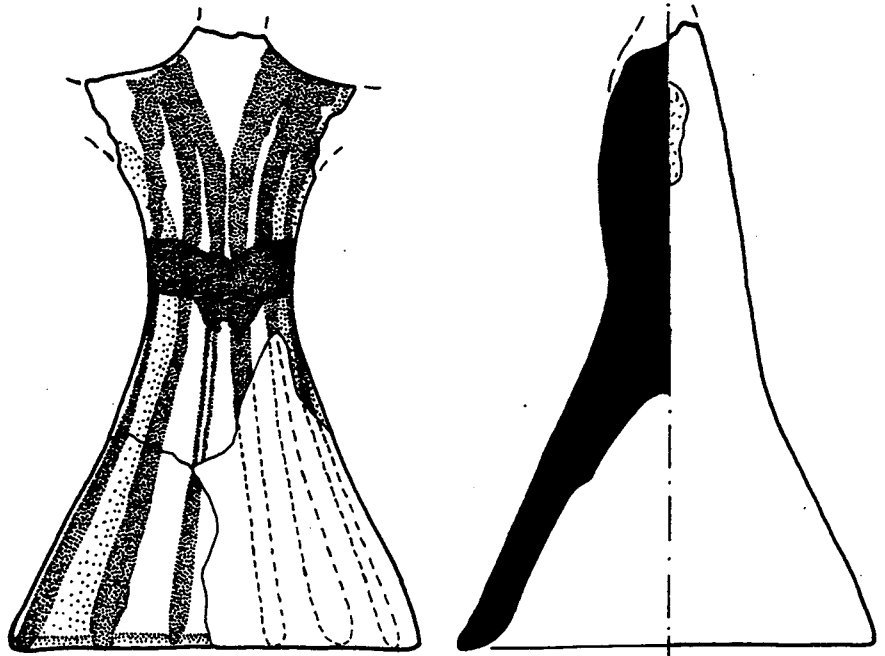
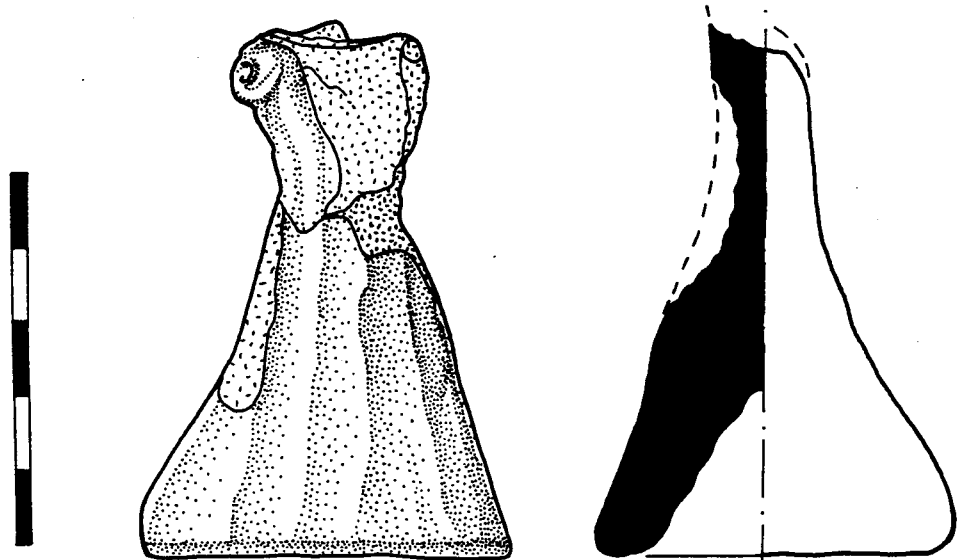

2

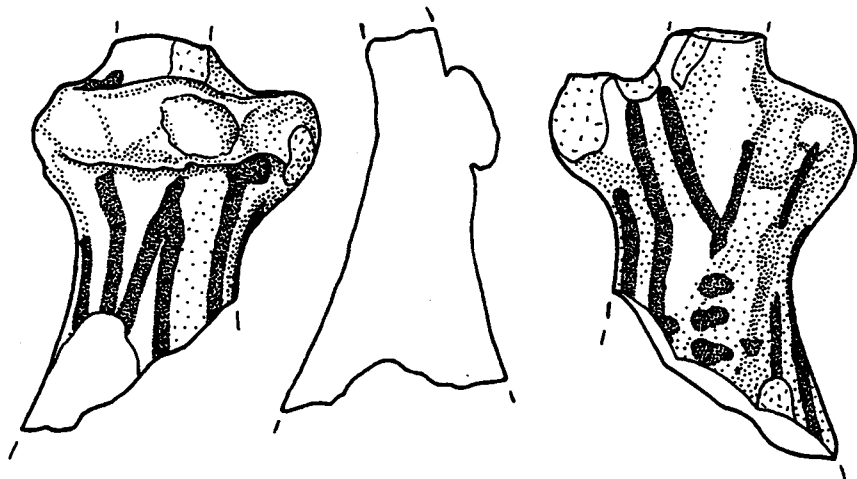

3

FIGURA 238



FIGURA 239



FIGURA 240

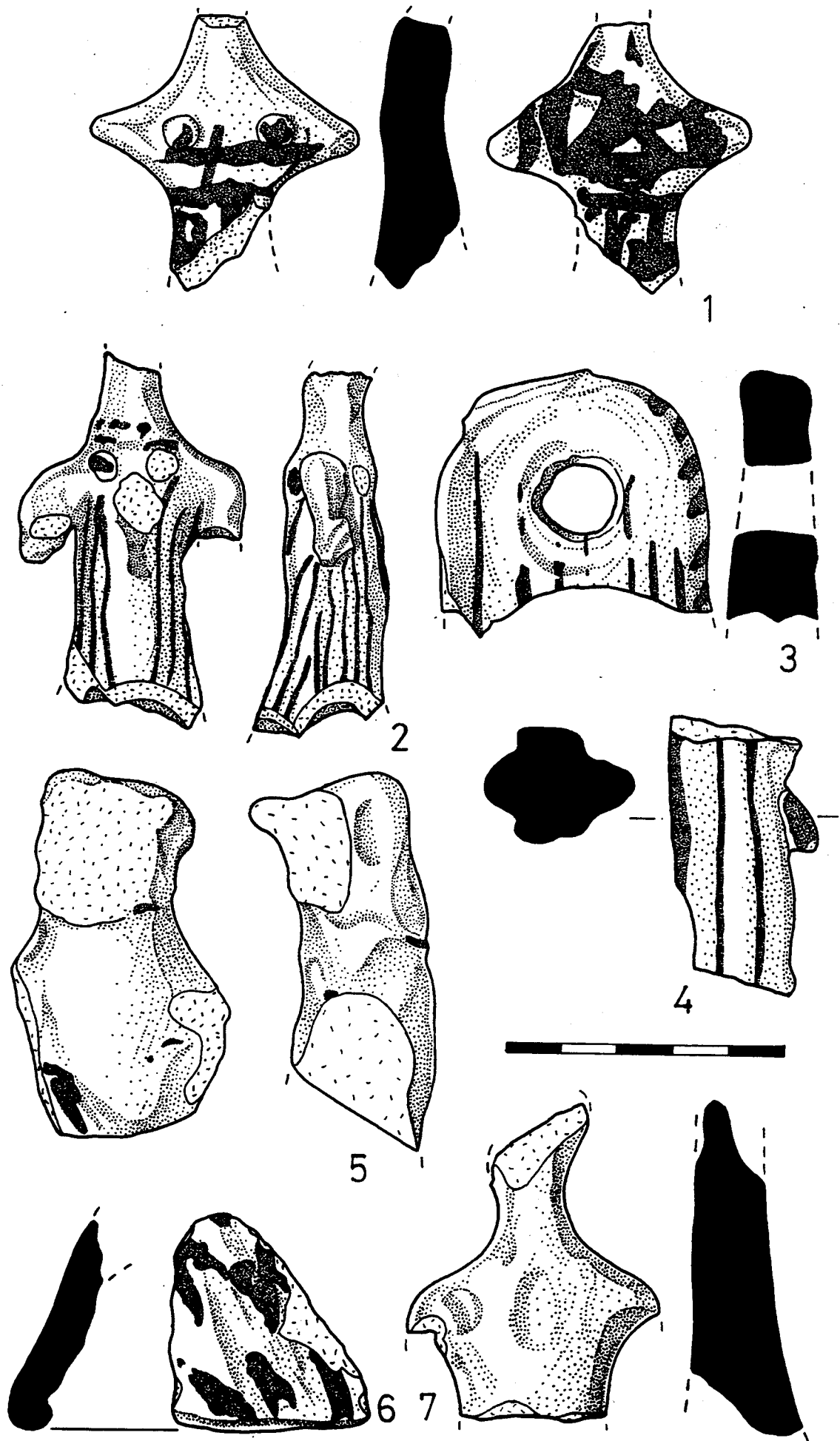

FIGURA 241

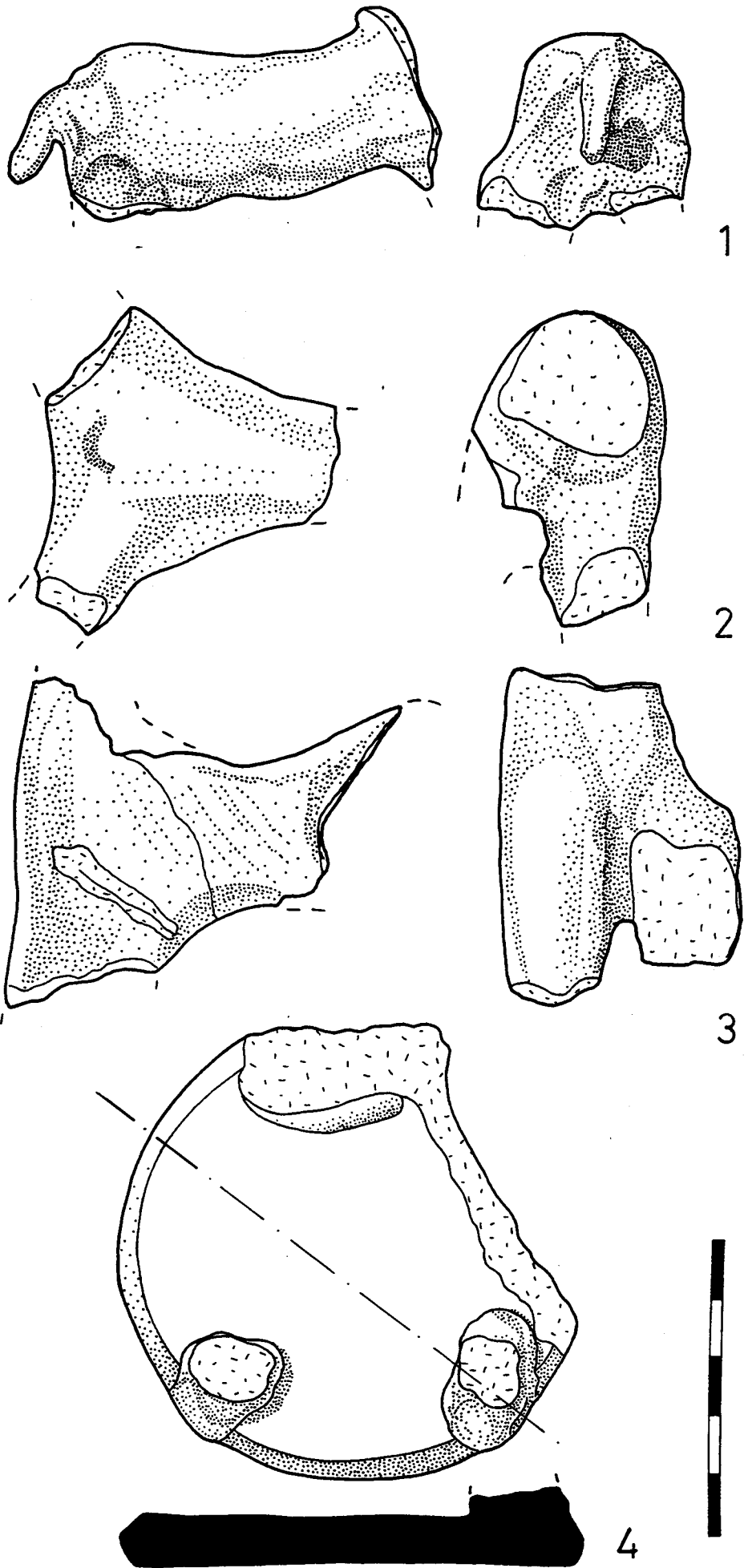

FIGURA 242

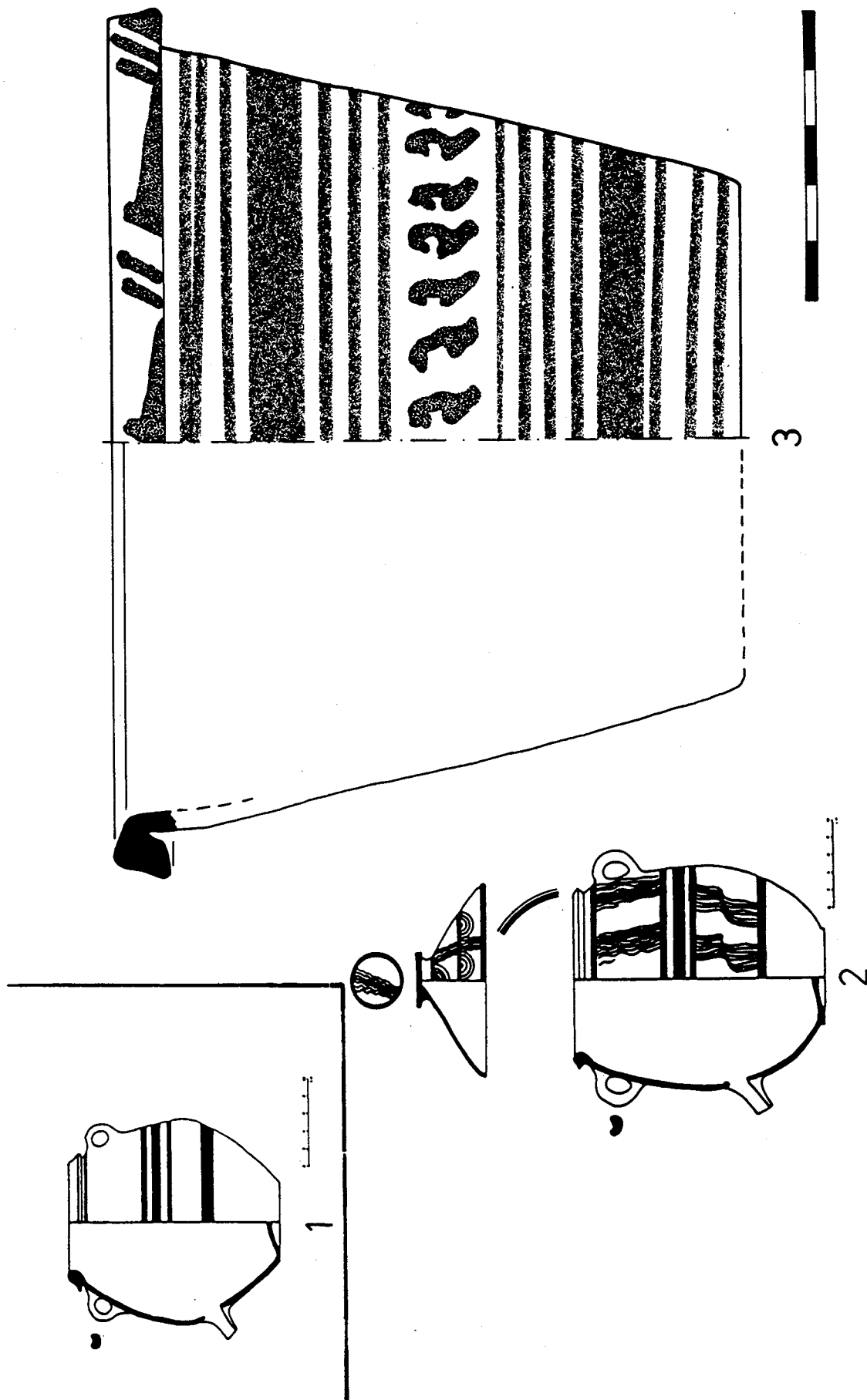

FIGURA 243

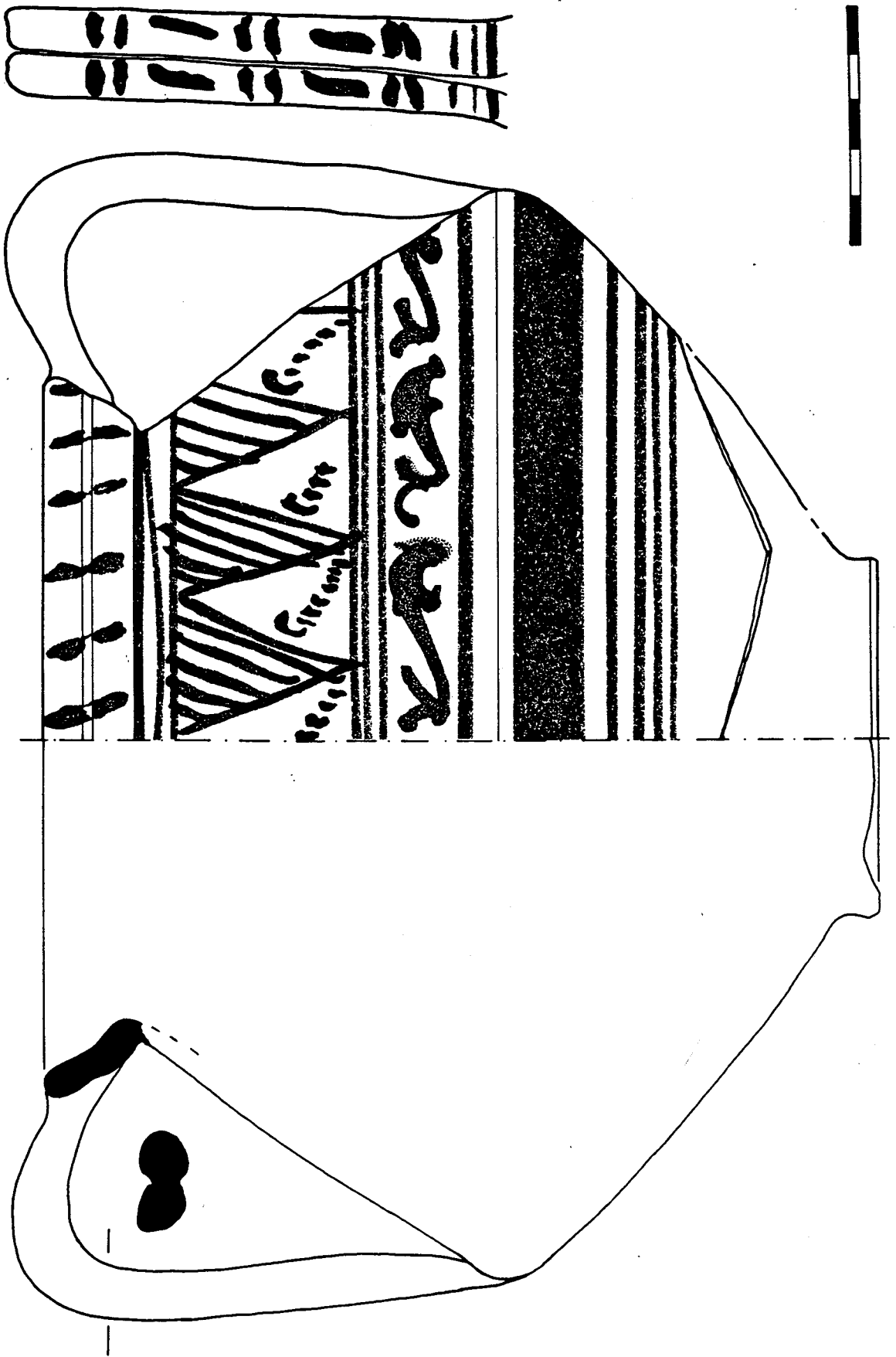

FIGURA 244

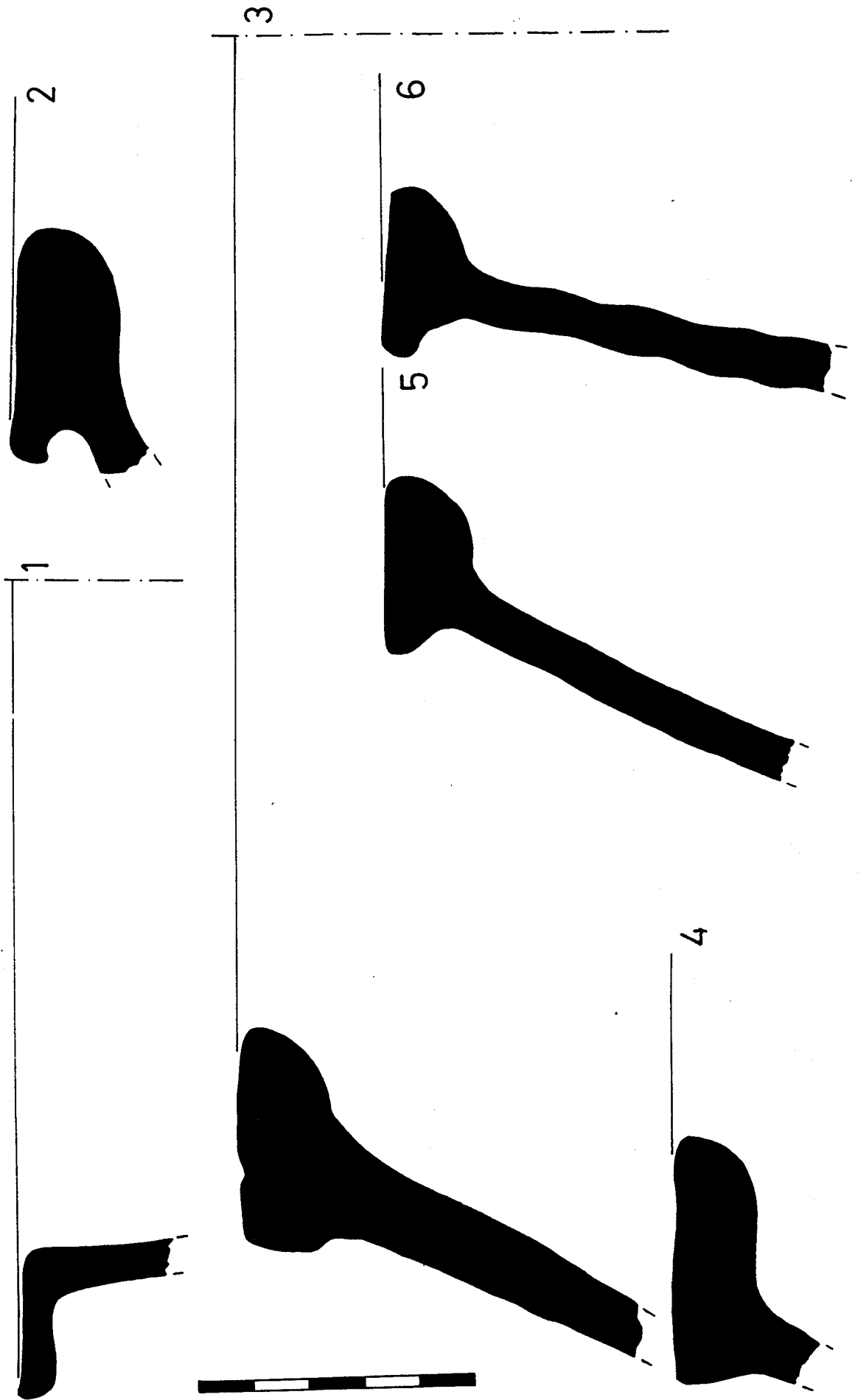

FIGURA 245

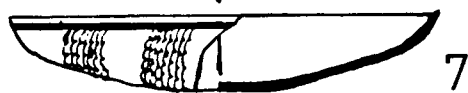
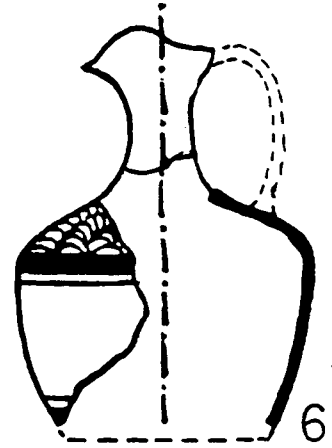
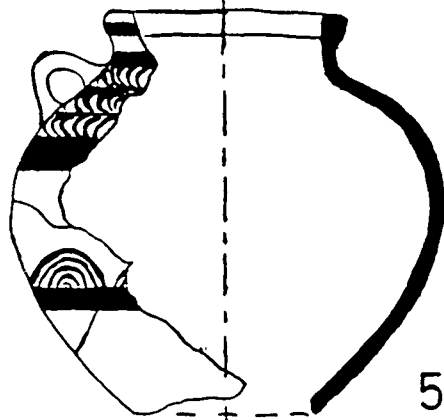
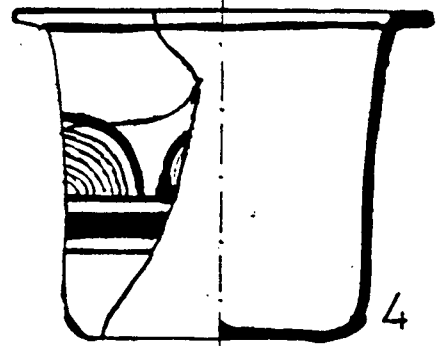
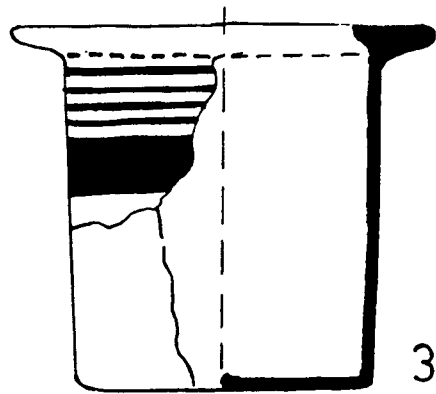
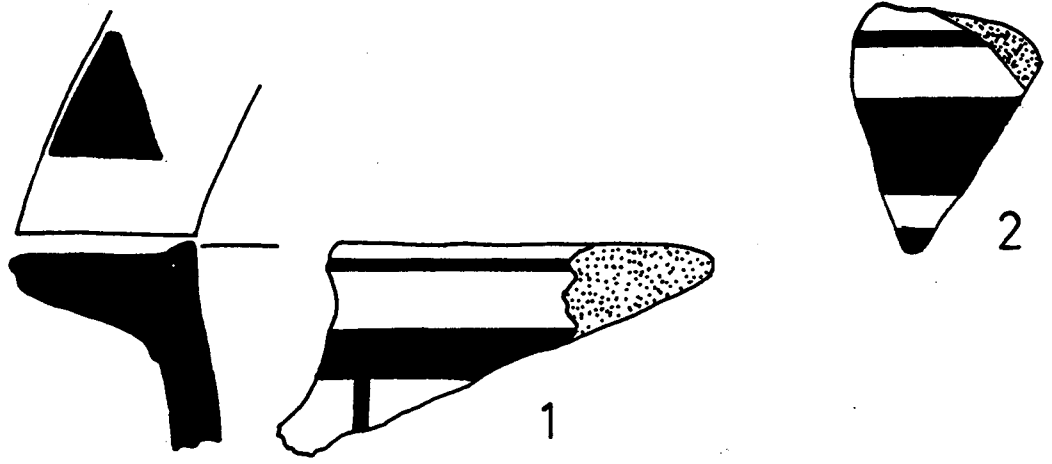

FIGURA 246

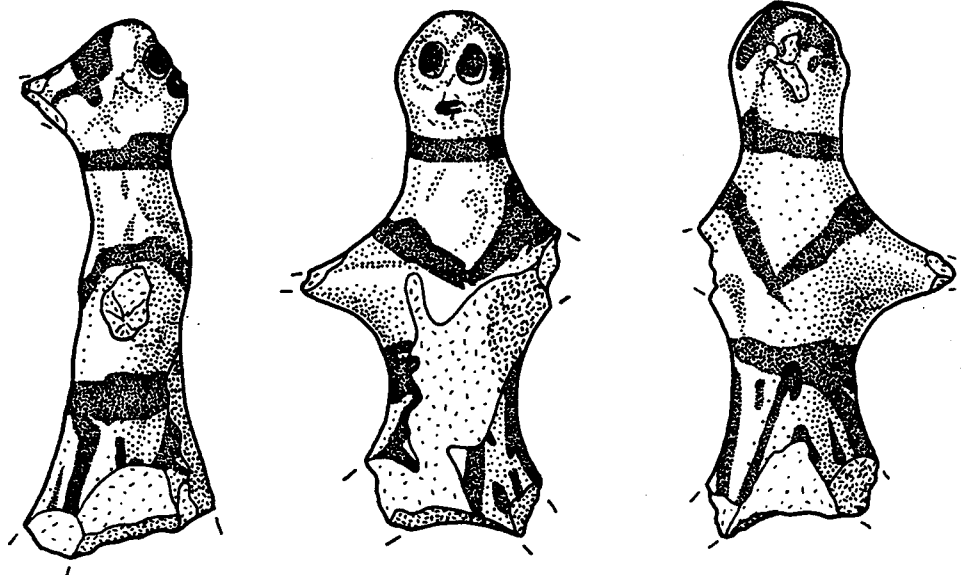

FIGURA 247

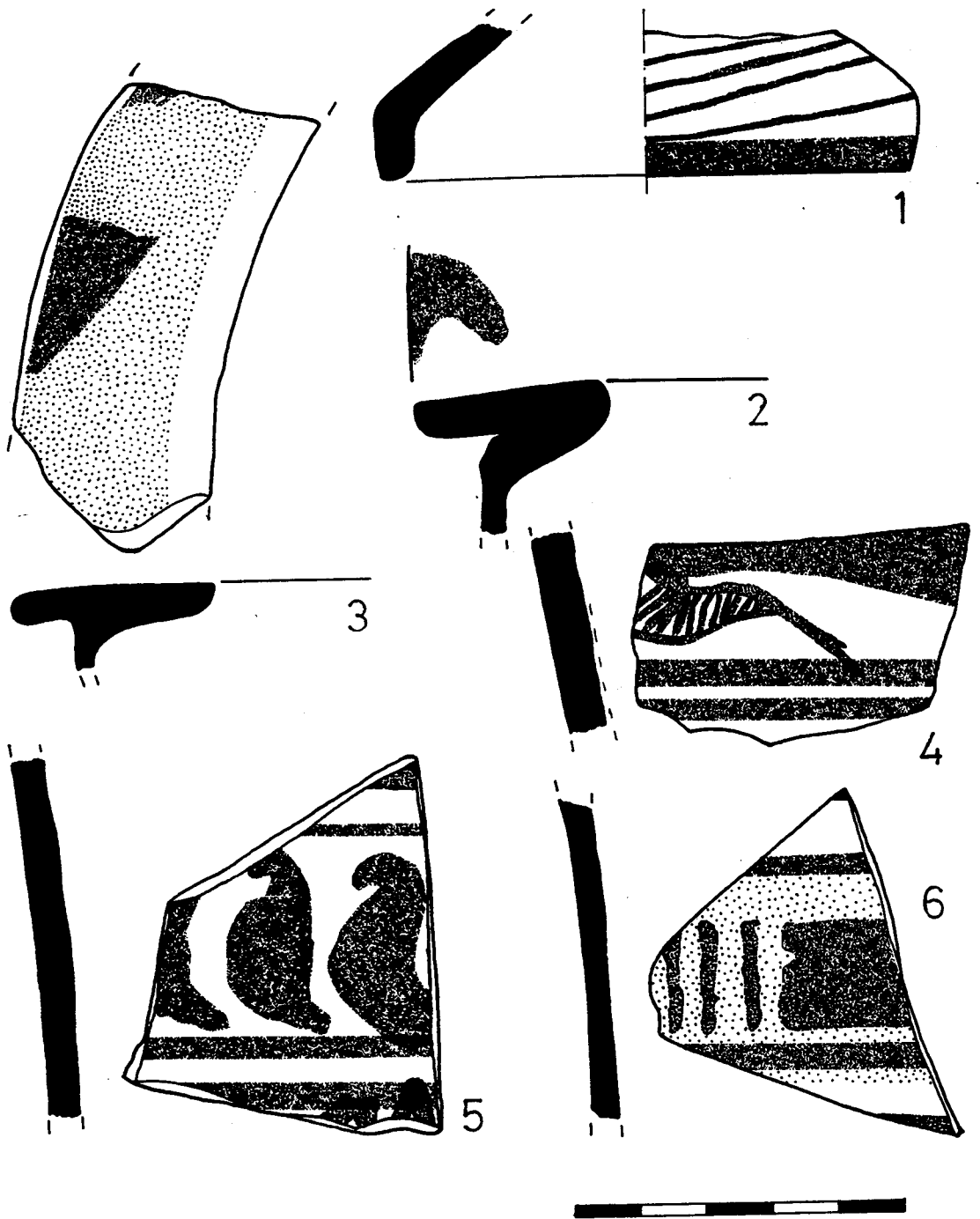

FIGURA 248

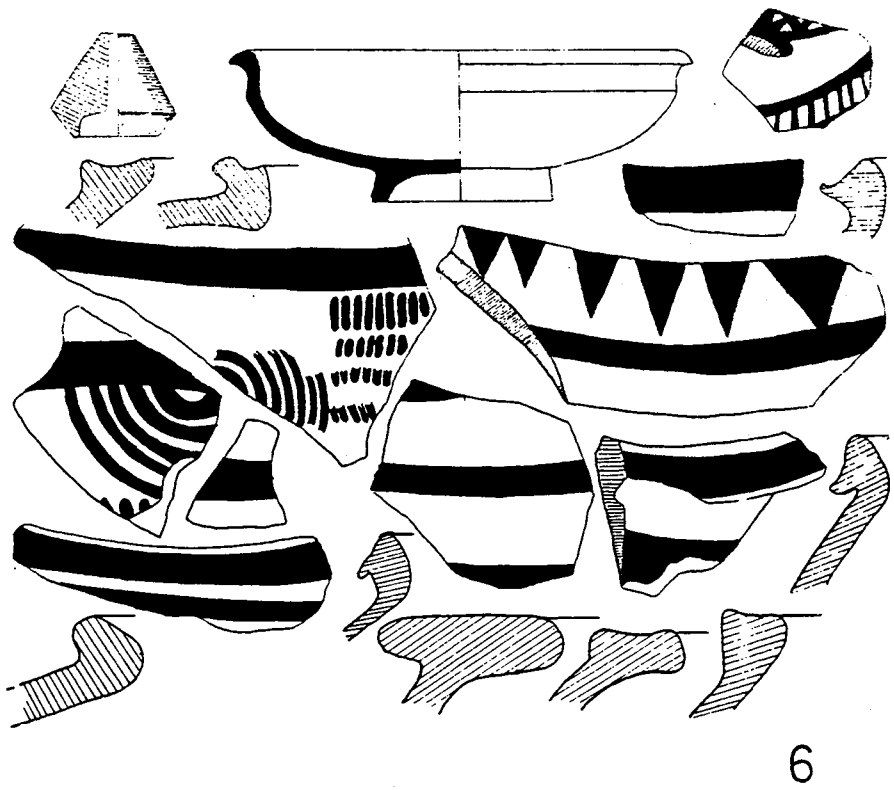
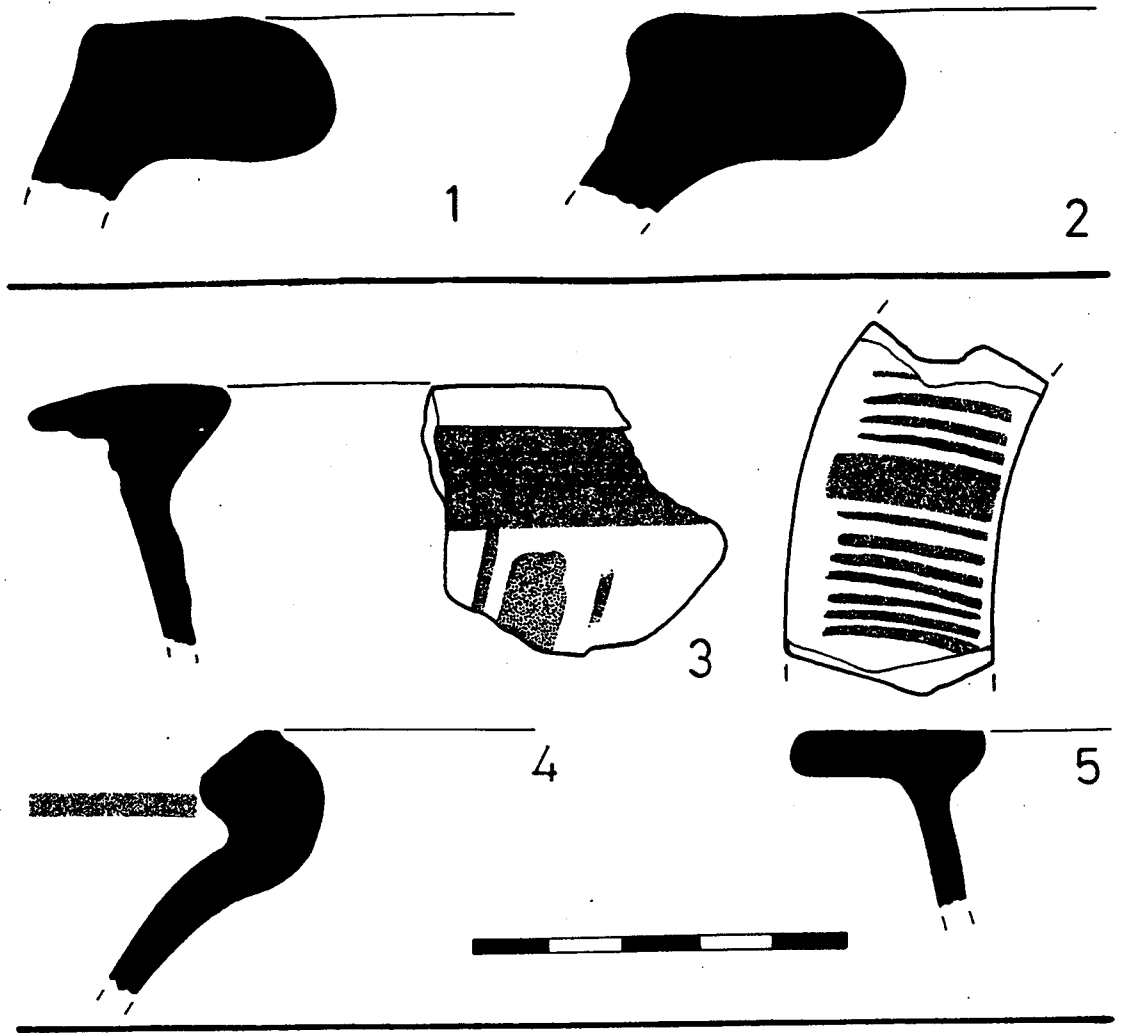

FIGURA 249

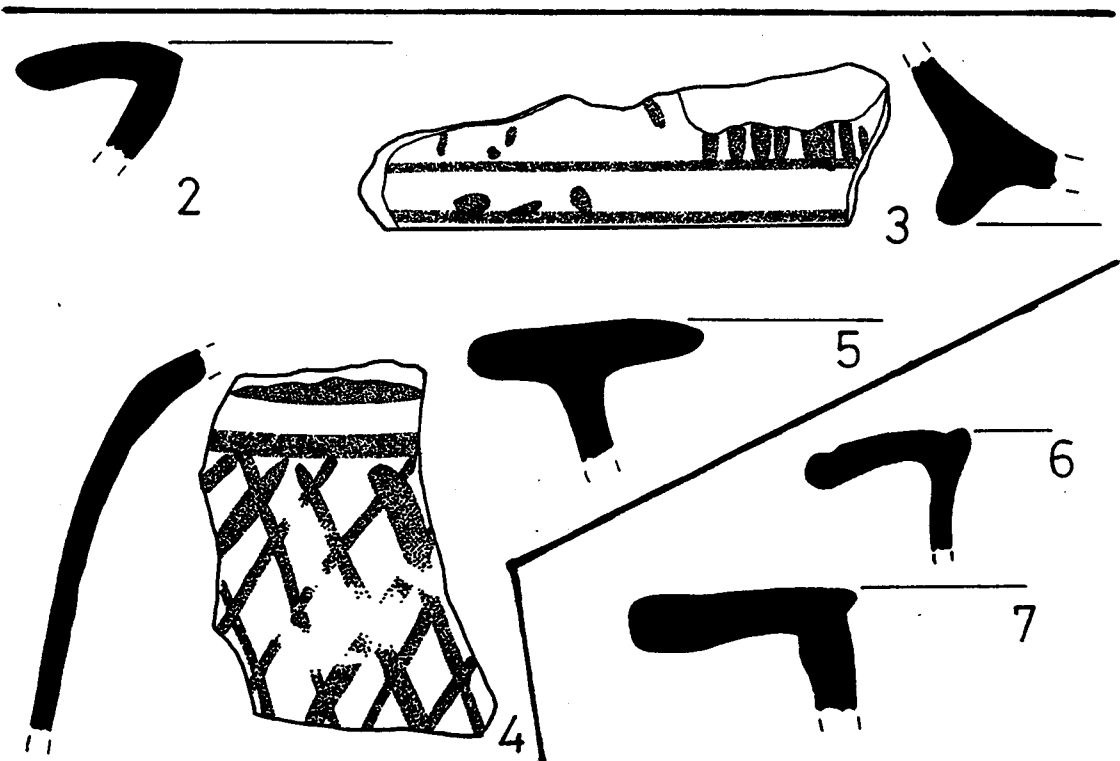
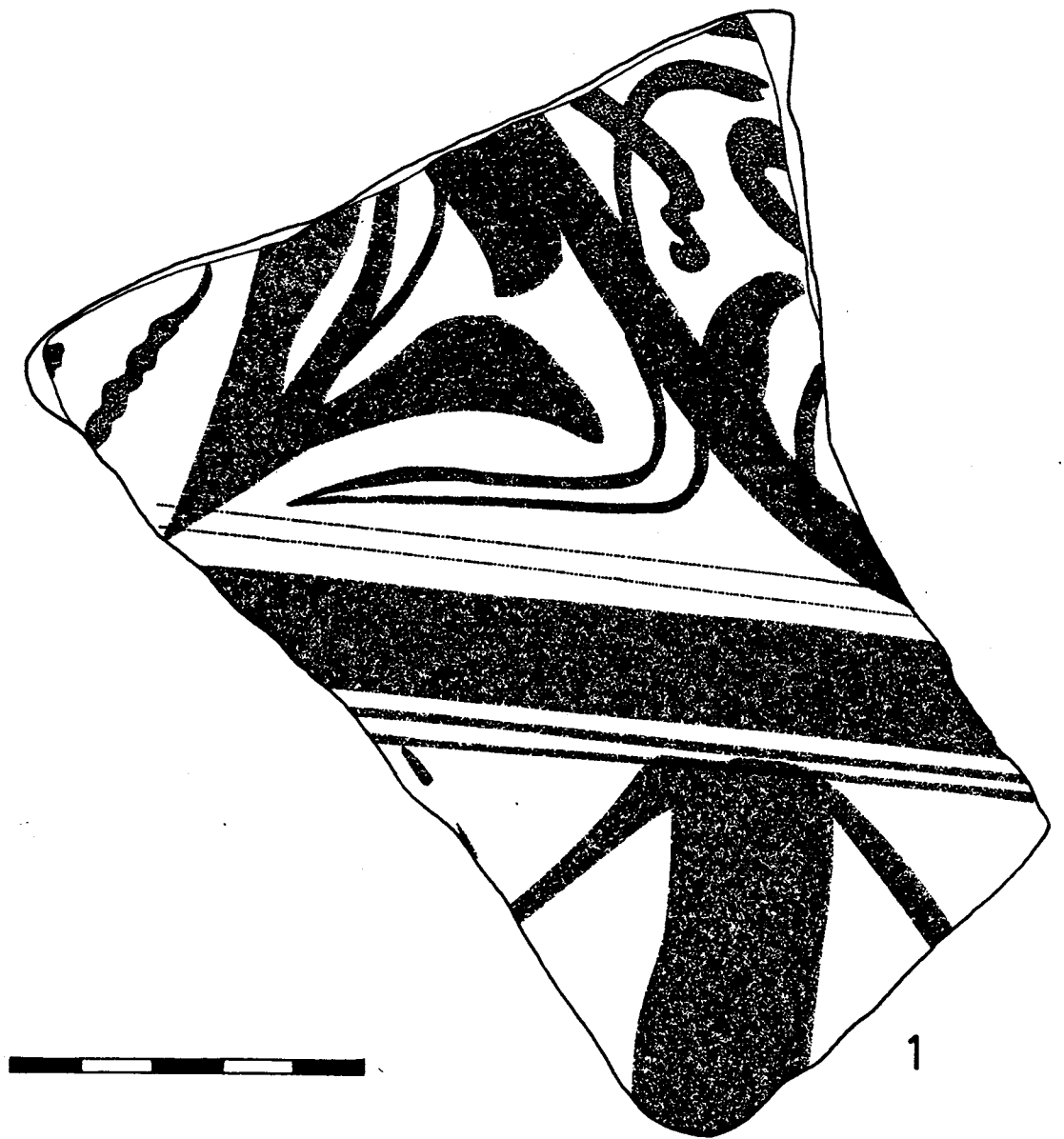

FIGURA 250

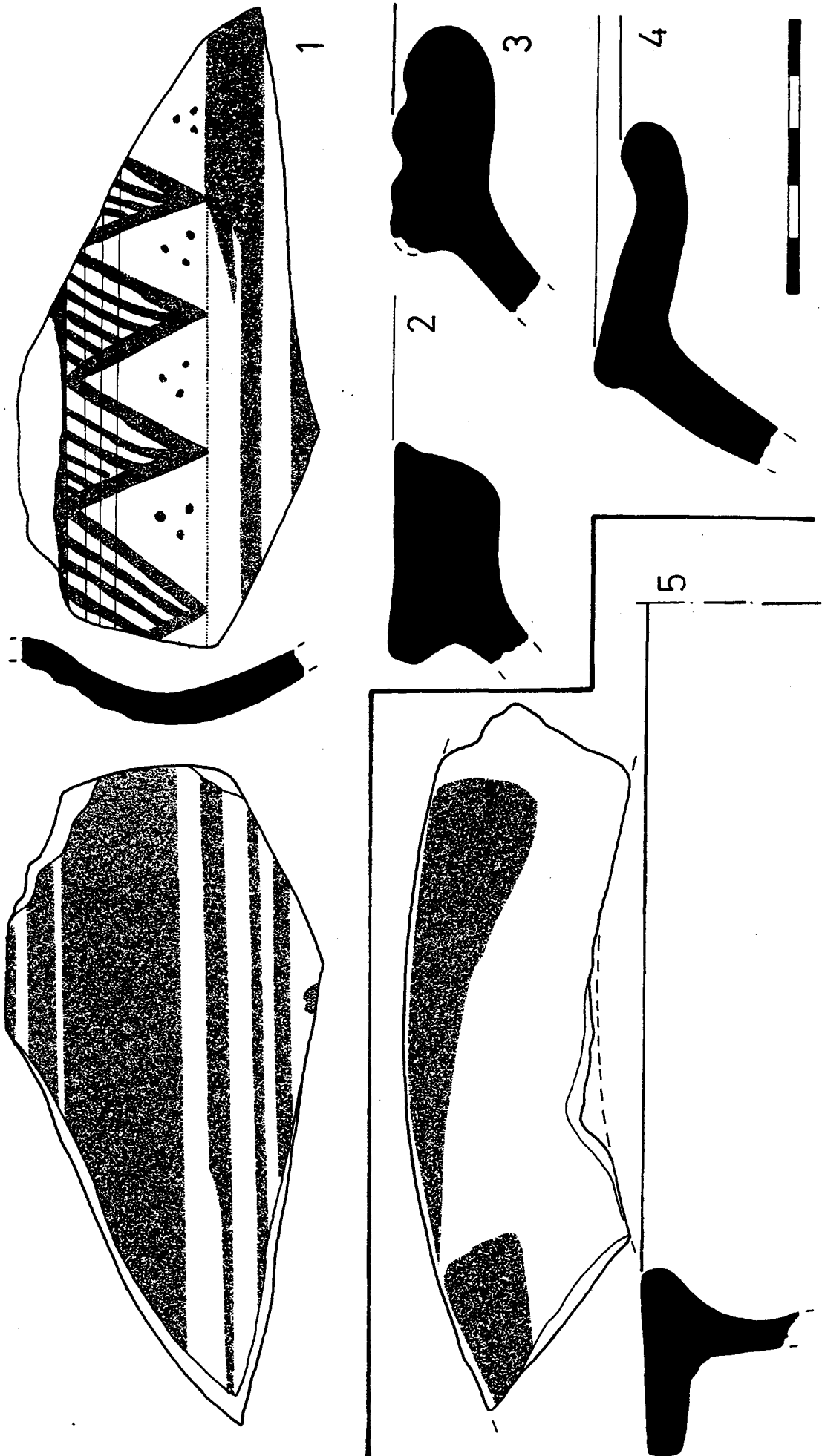

FIGURA 251

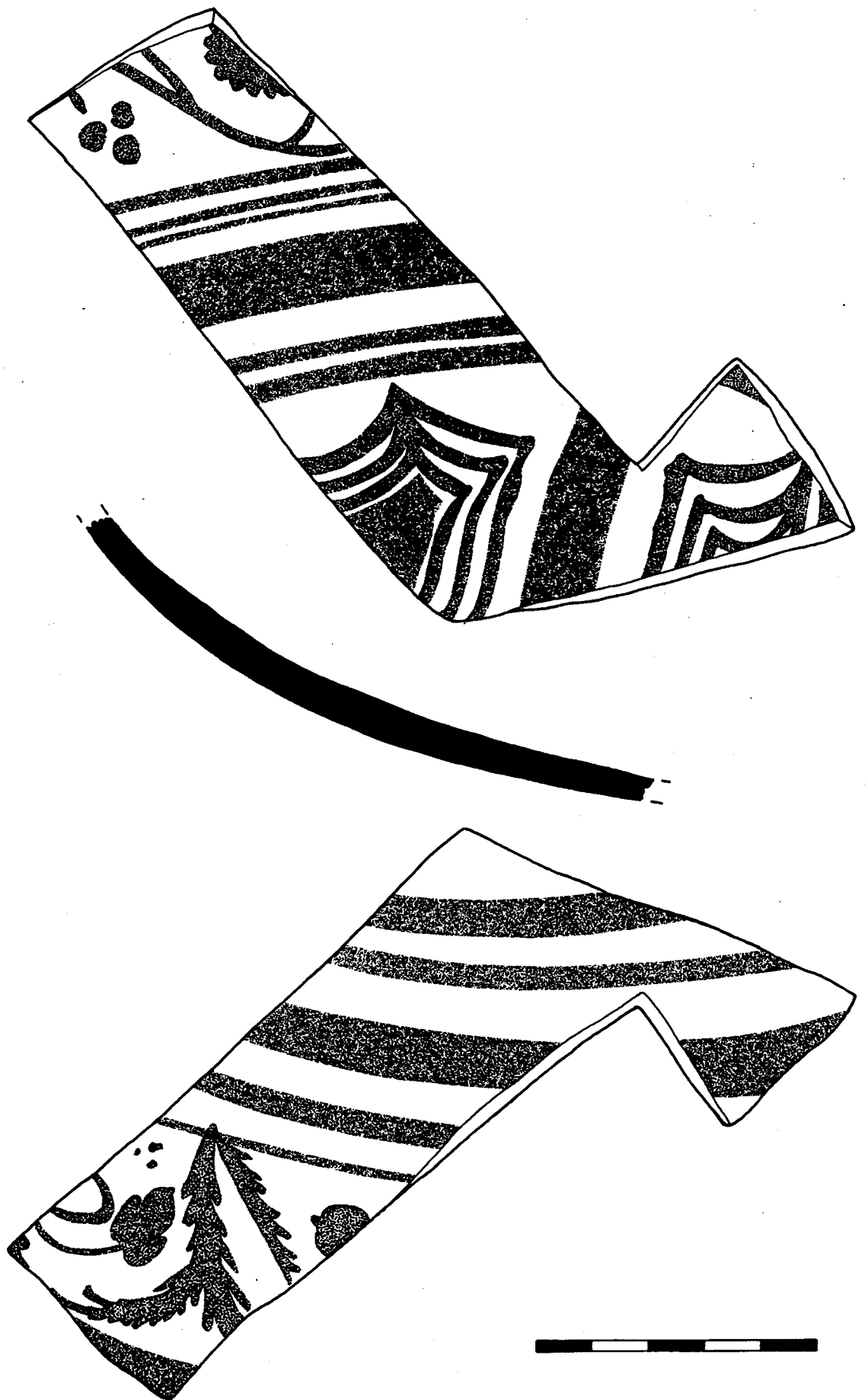

Escala 1 : 1

FIGURA 252

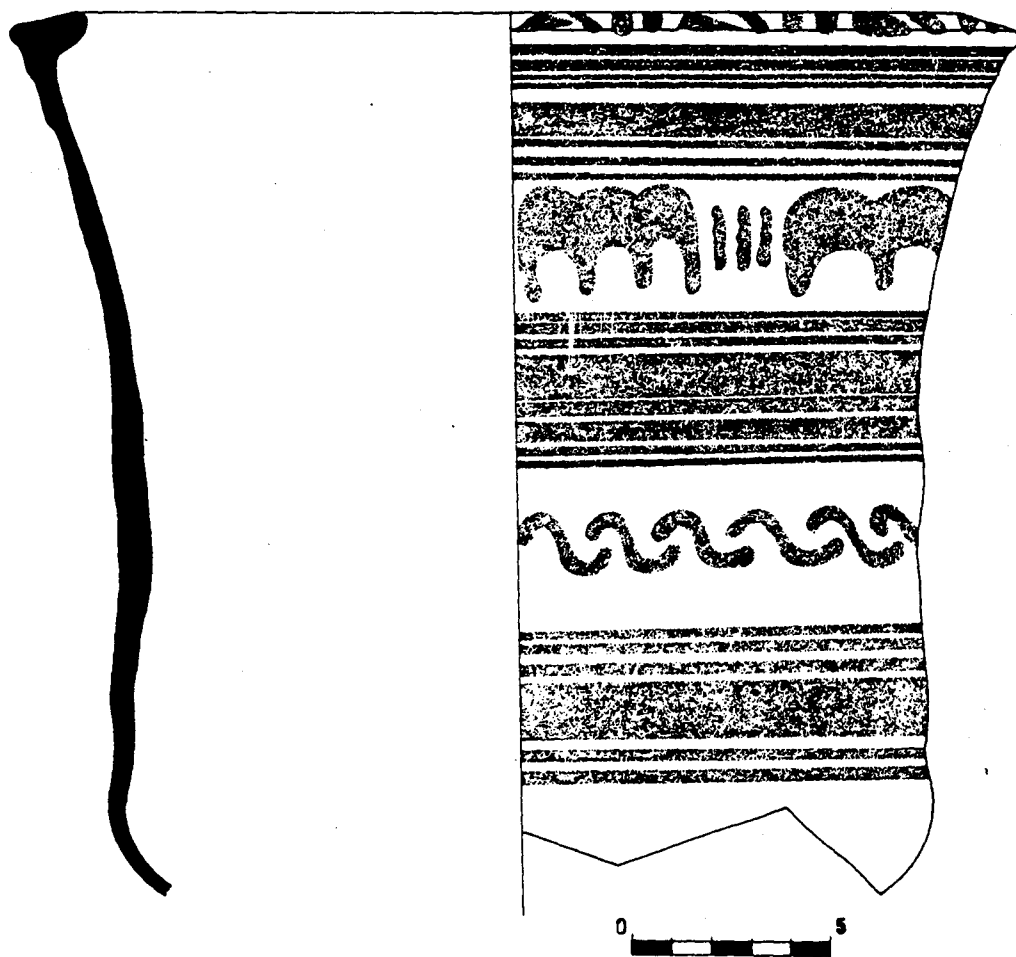
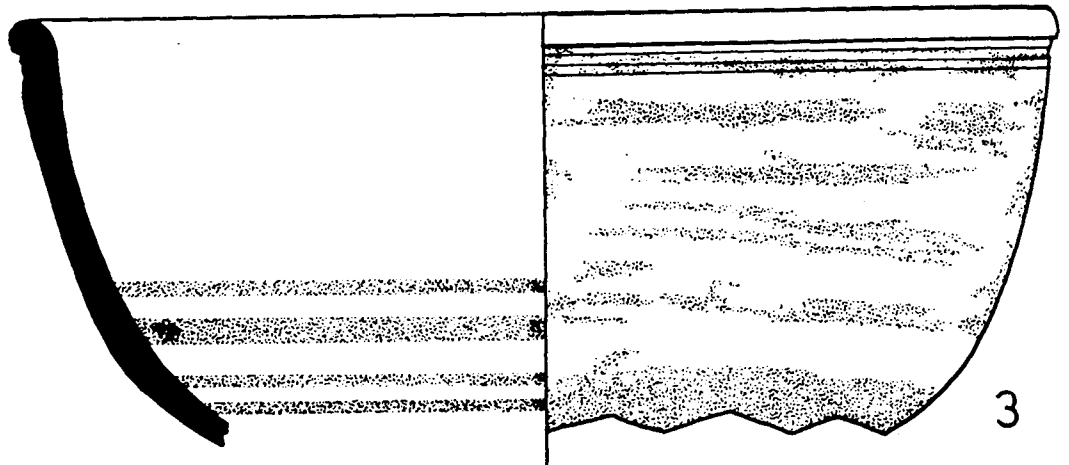
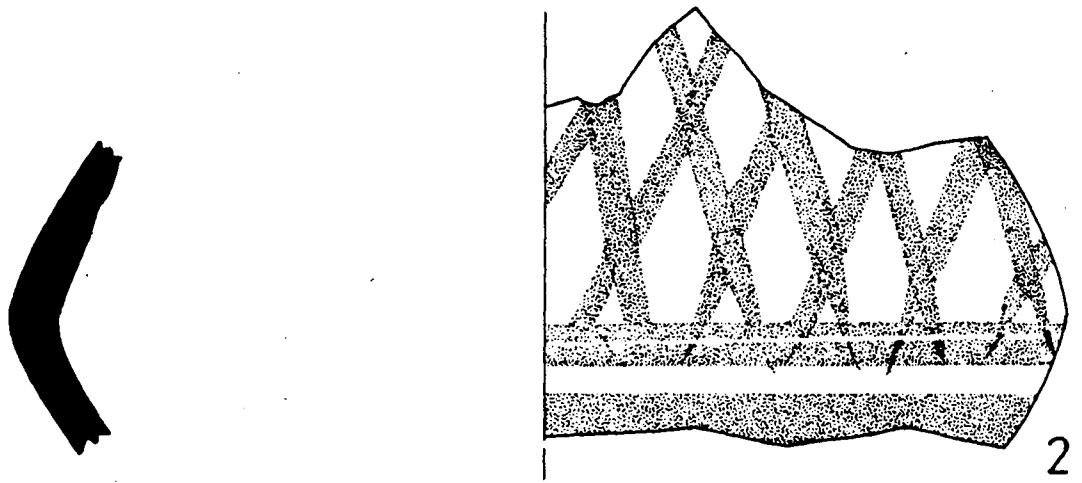
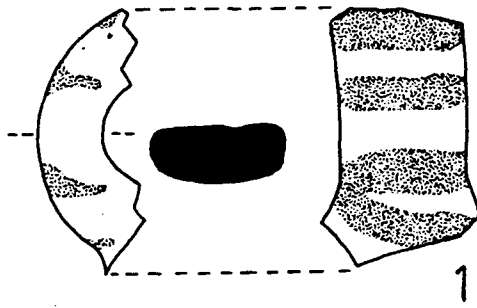

FIGURA 253



FIGURA 254

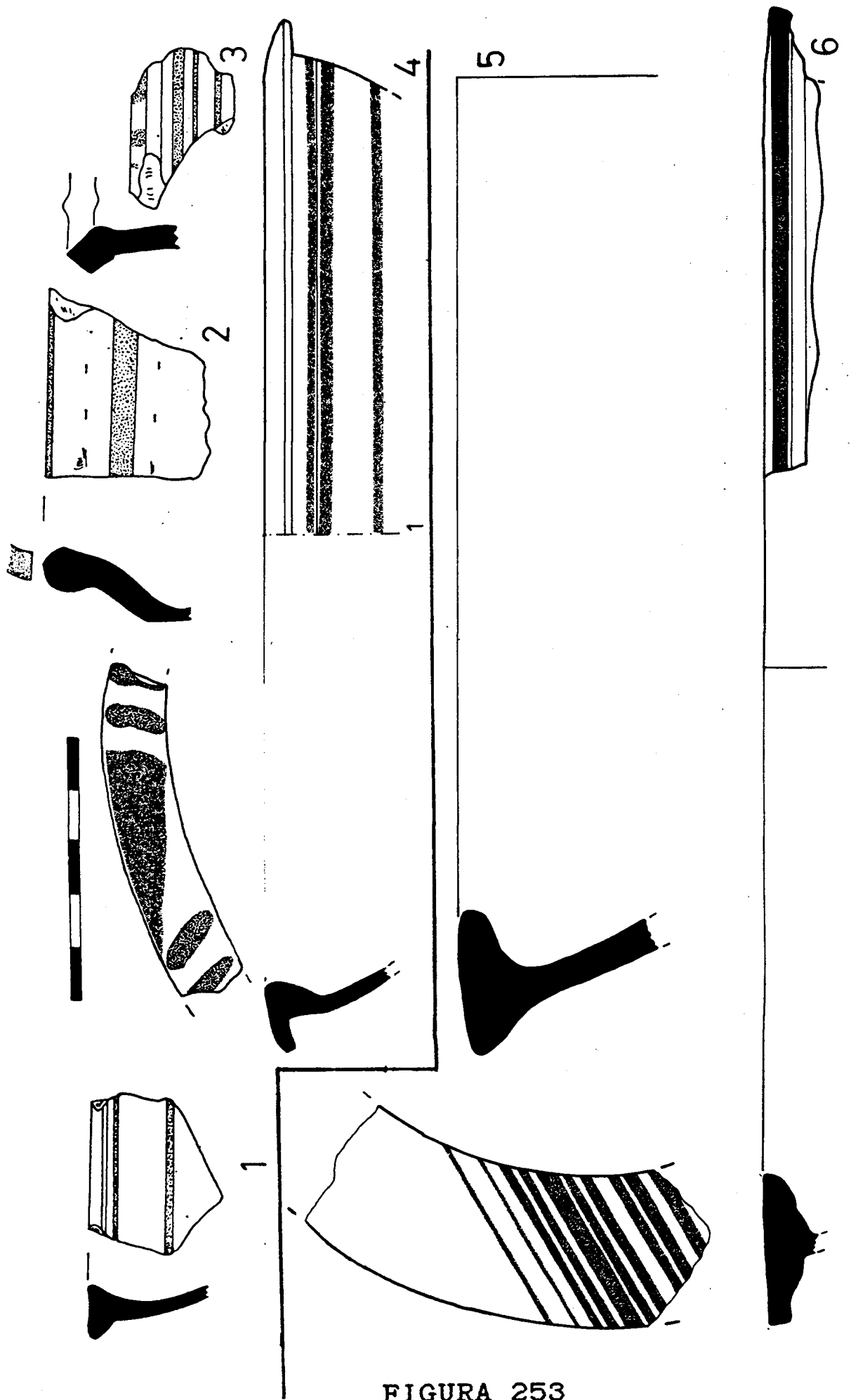

FIGURA 255

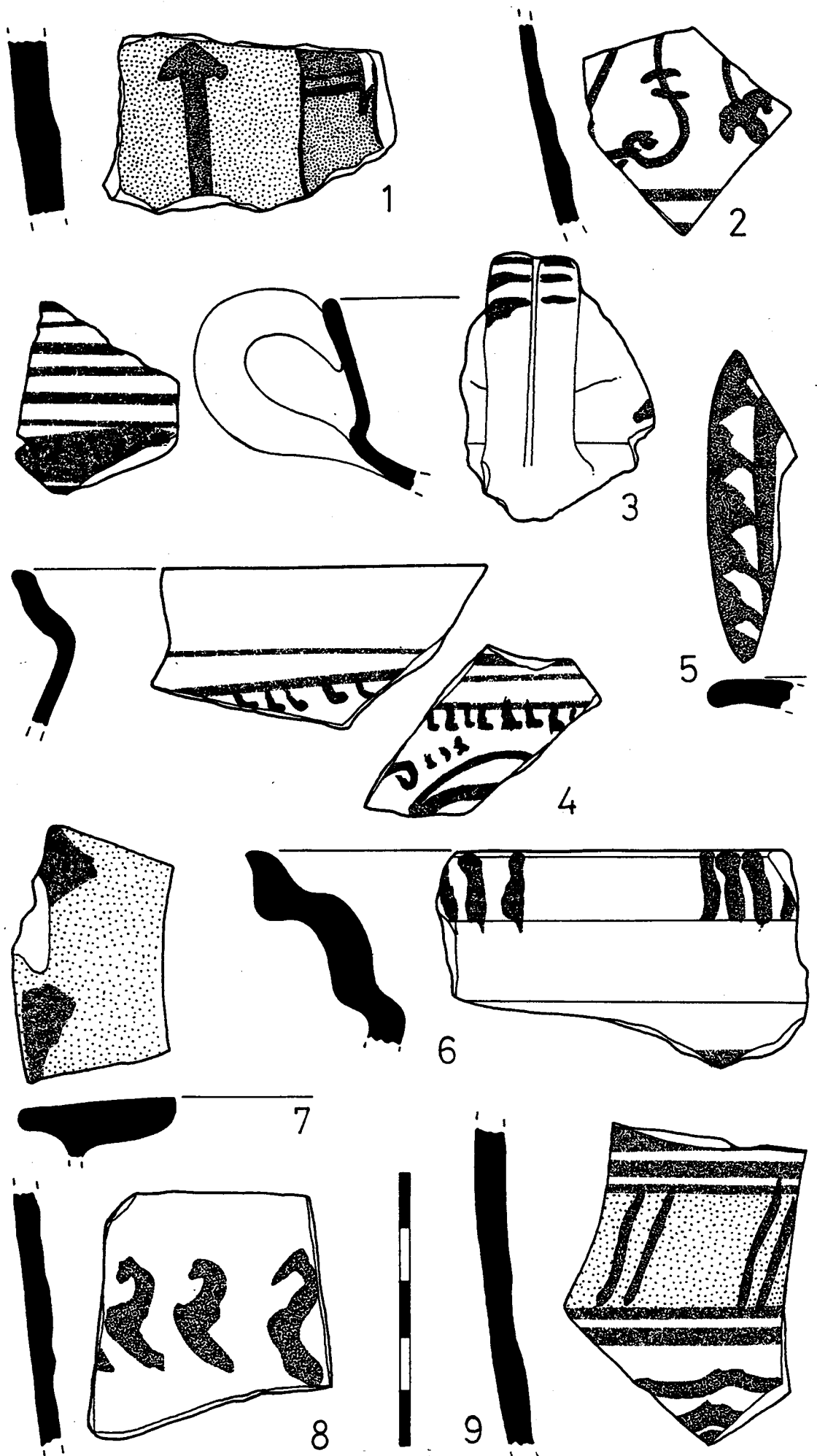

FIGURA 256

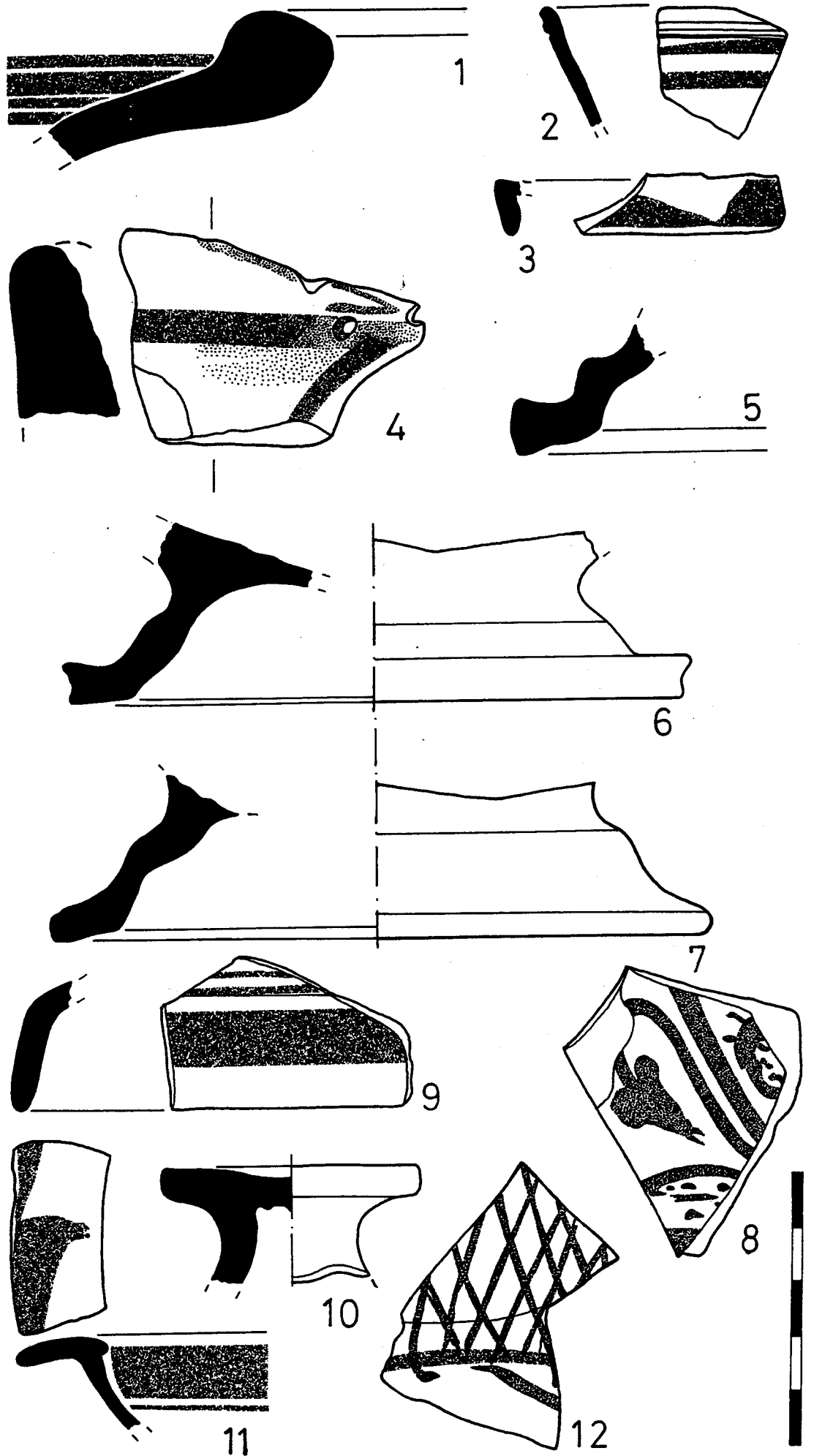

FIGURA 257

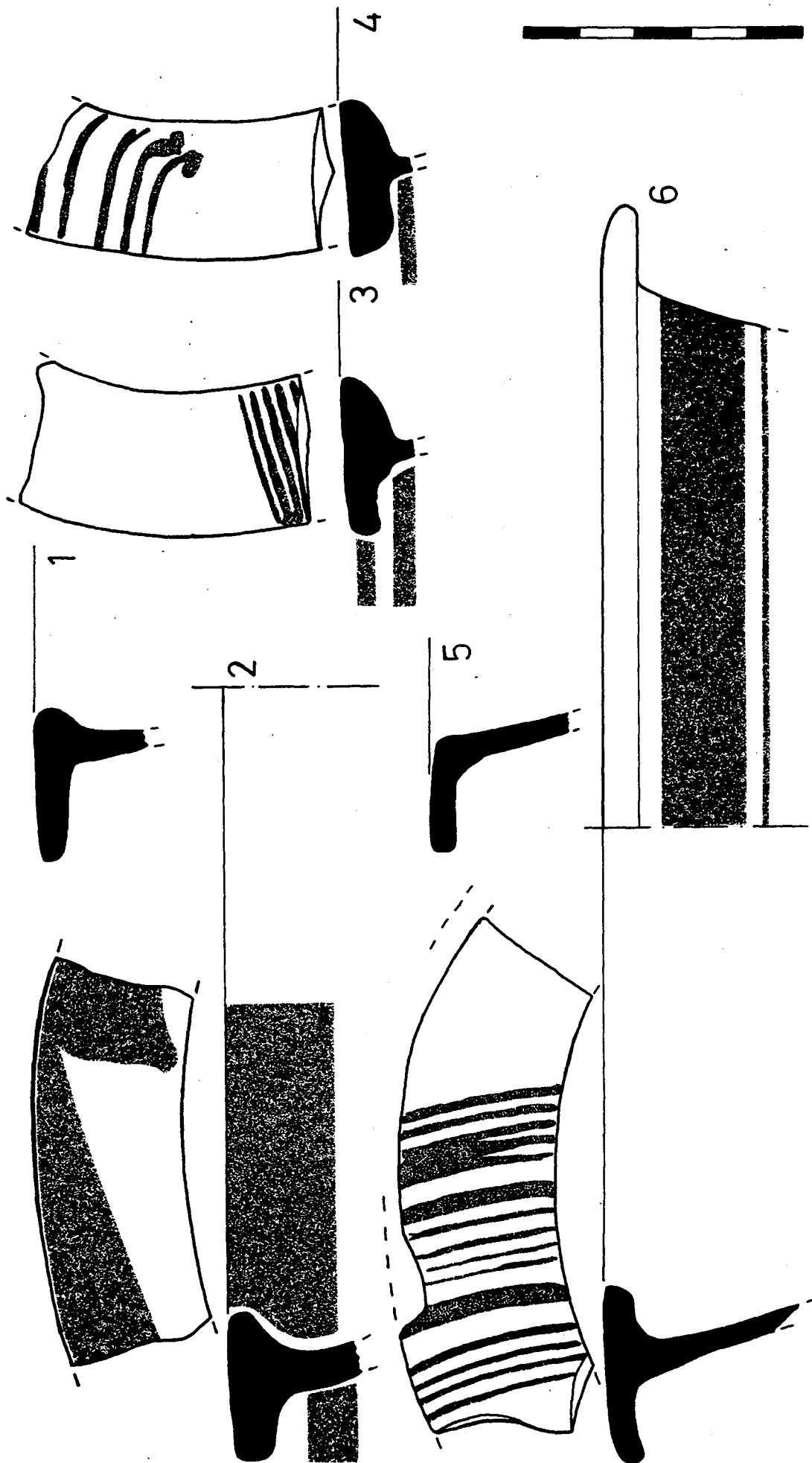

FIGURA 258

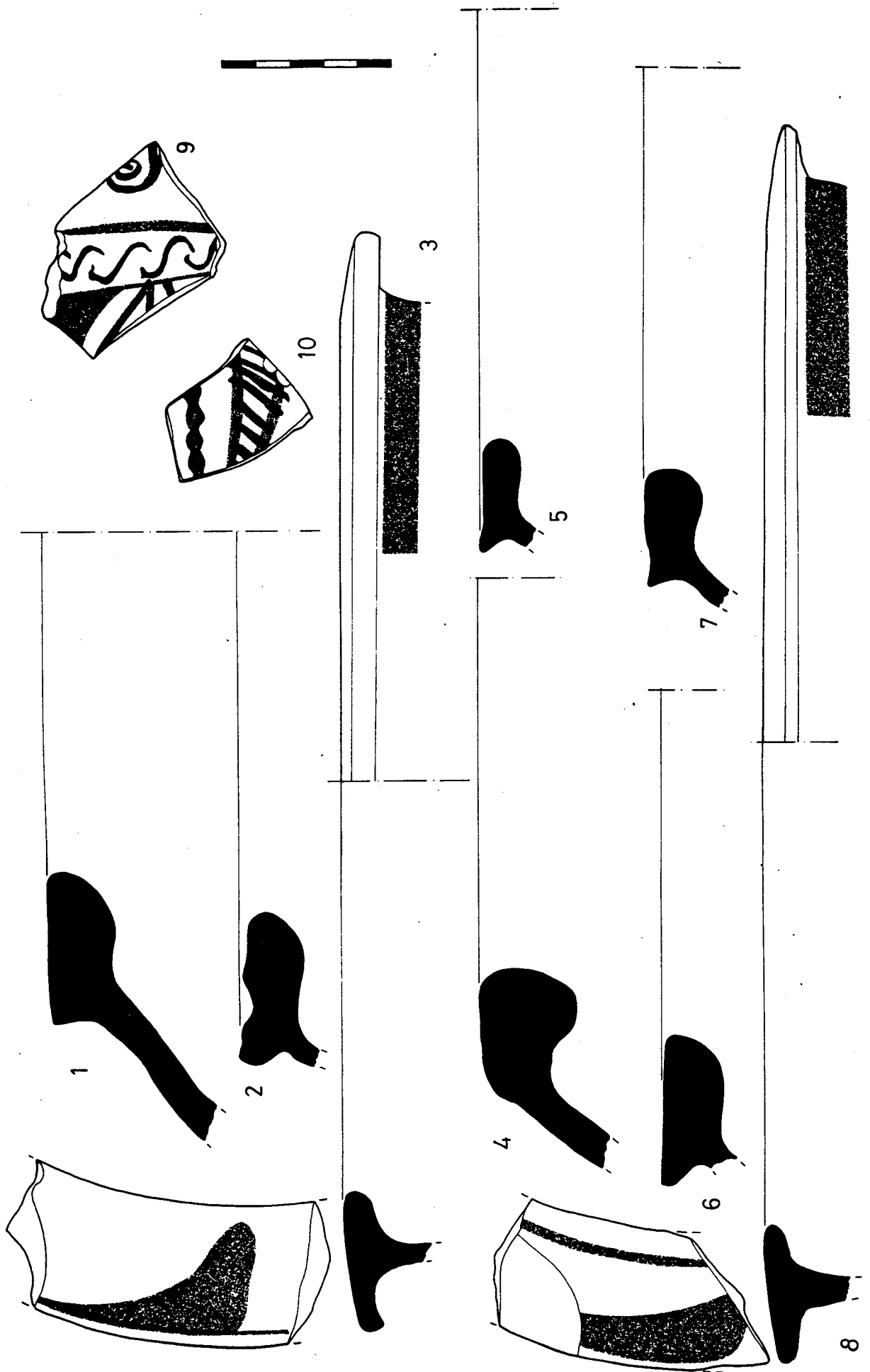

FIGURA 259

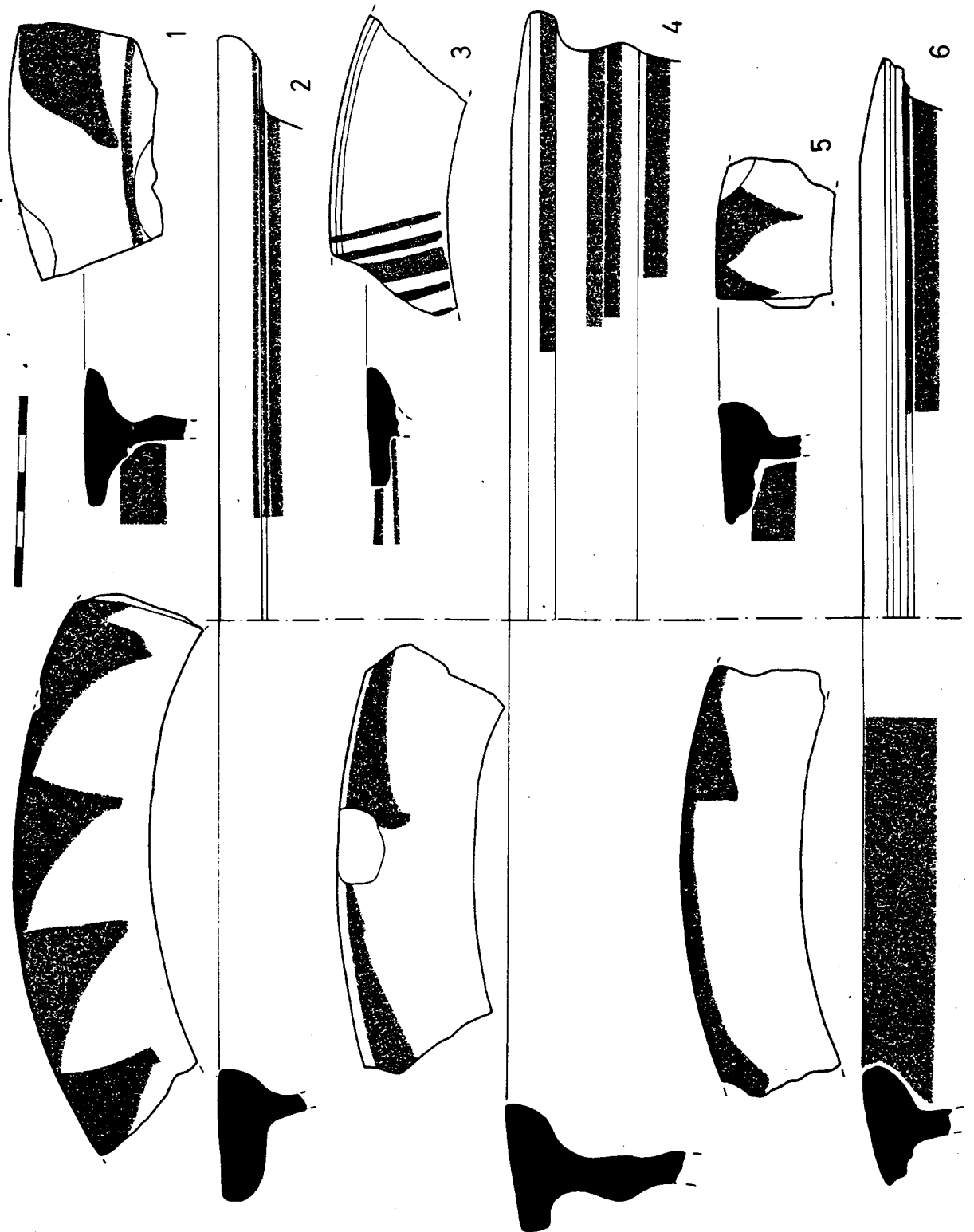

FIGURA 260

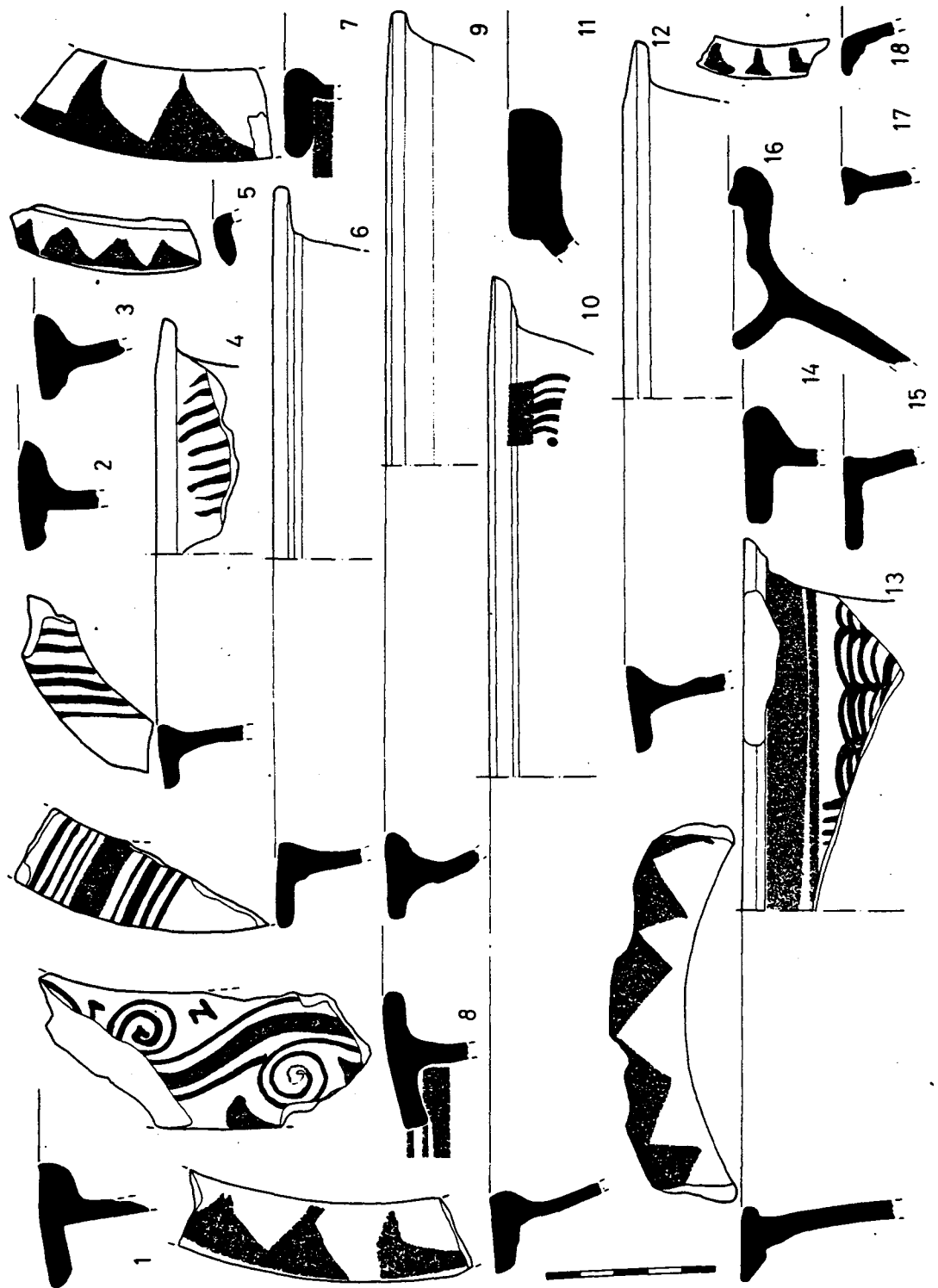

FIGURA 261

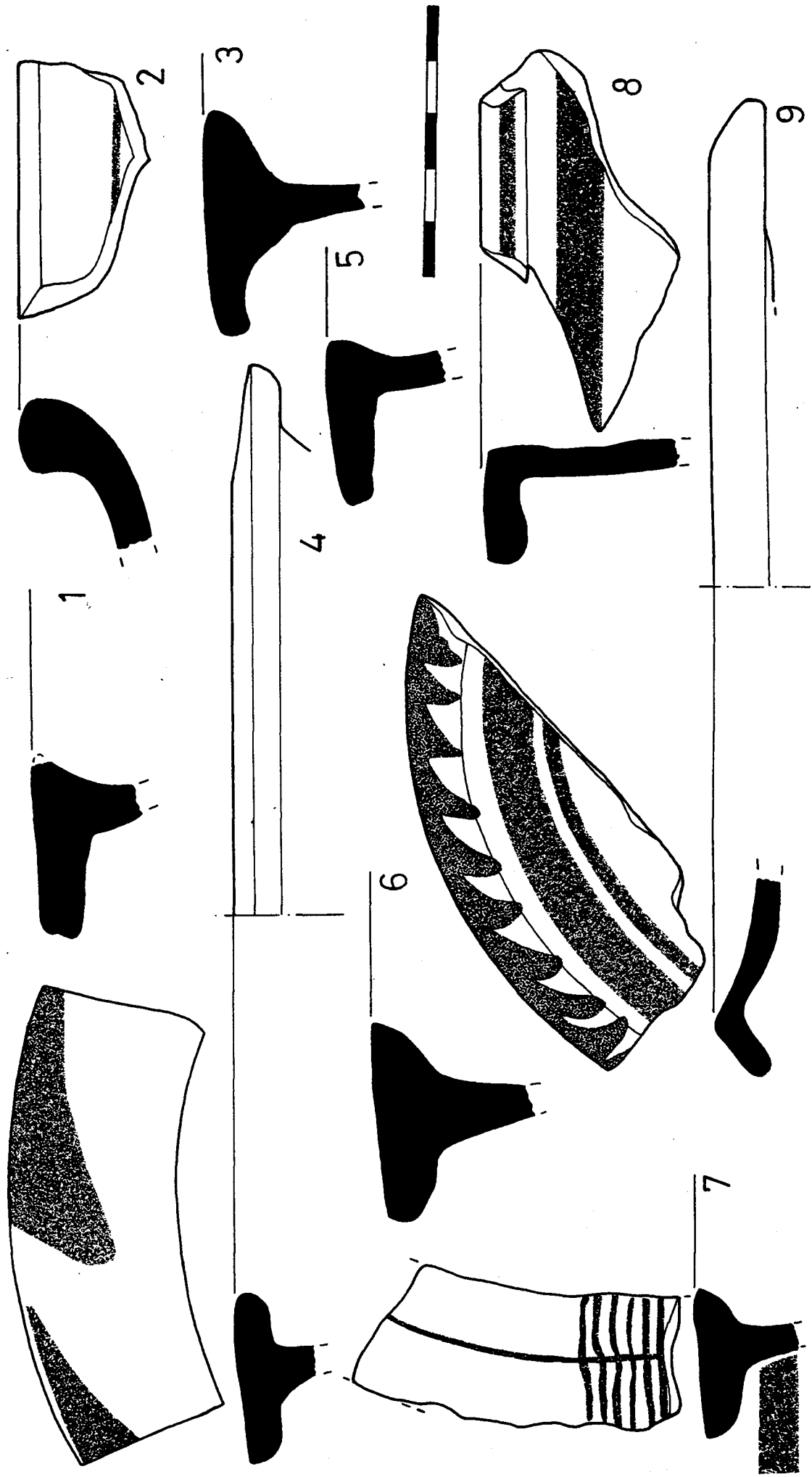

FIGURA 262

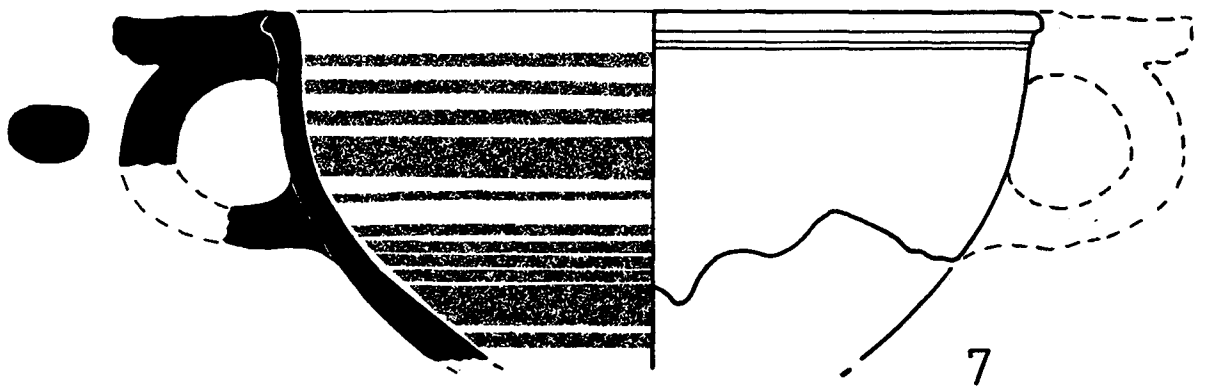
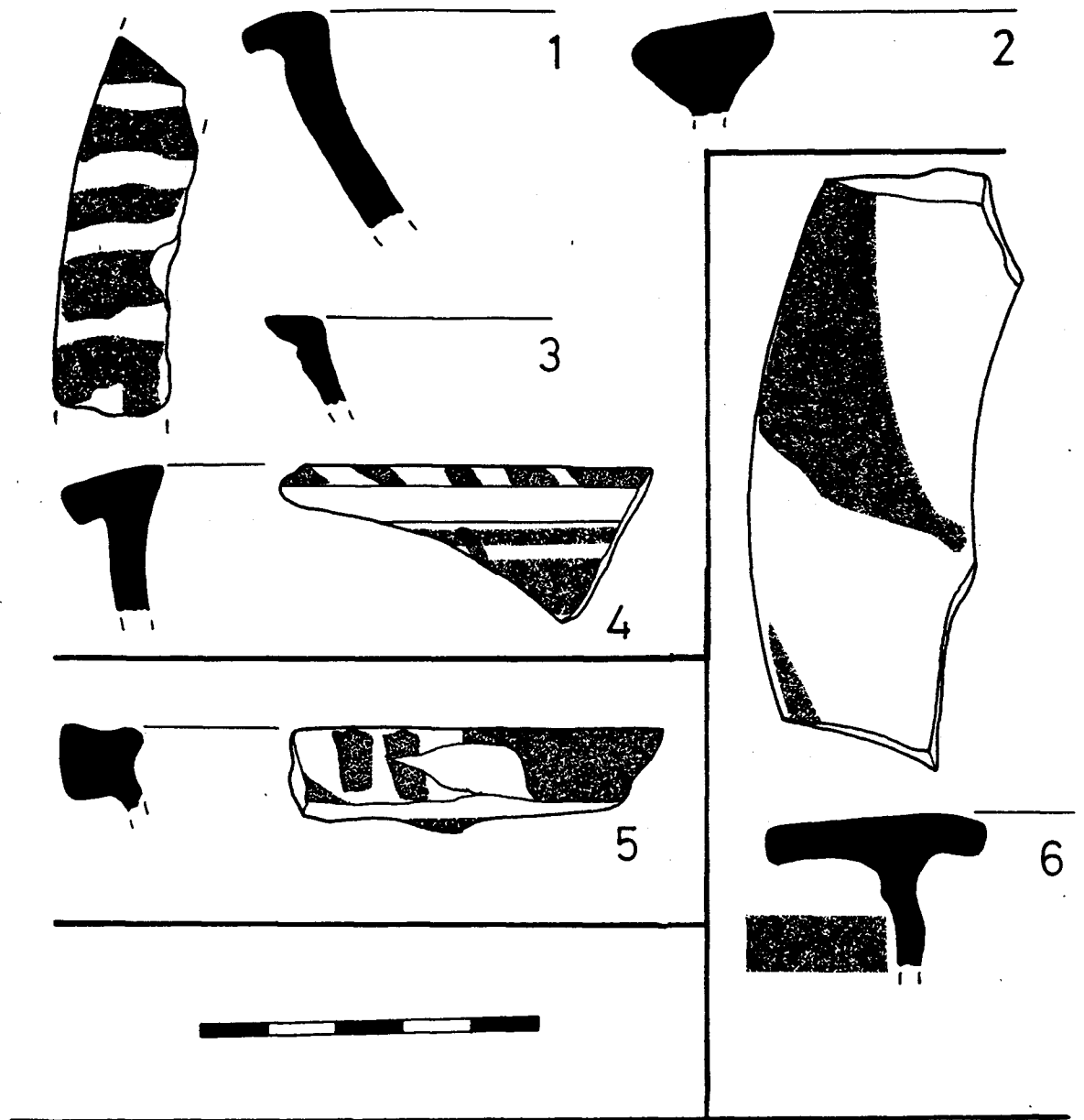

10 cm

FIGURA 263

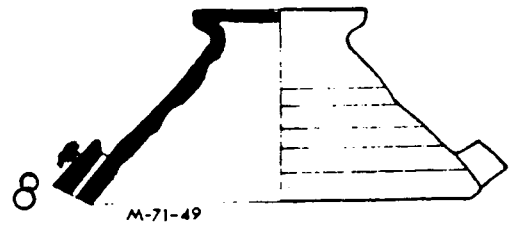
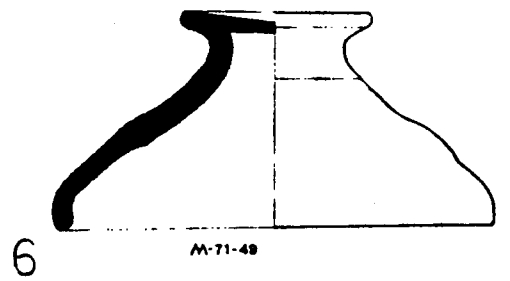
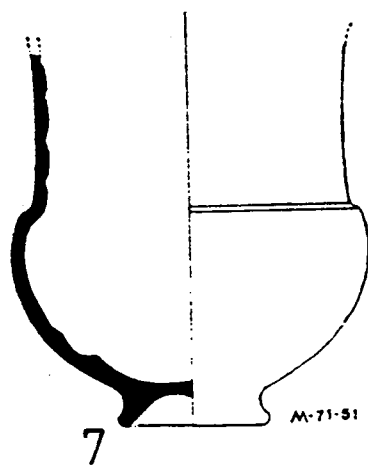
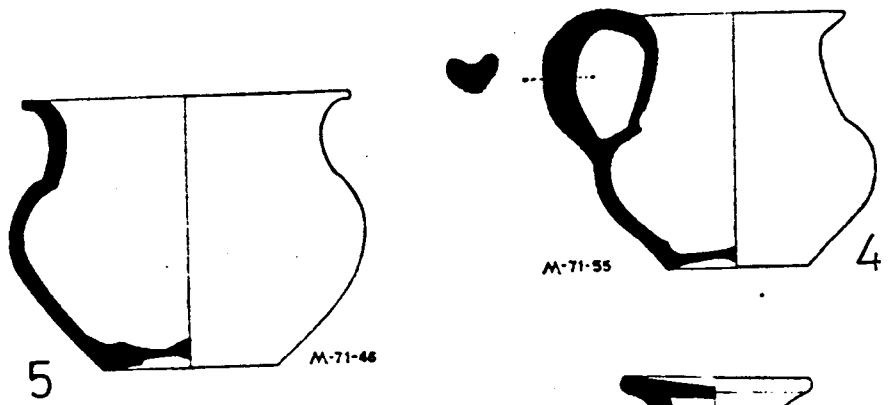
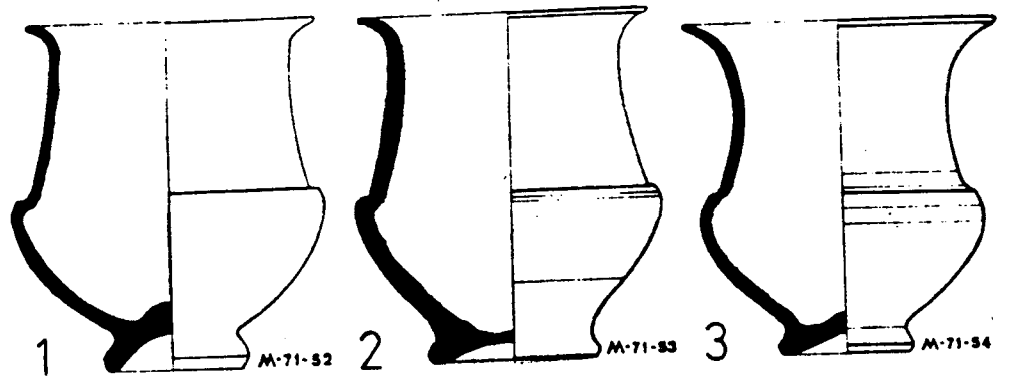
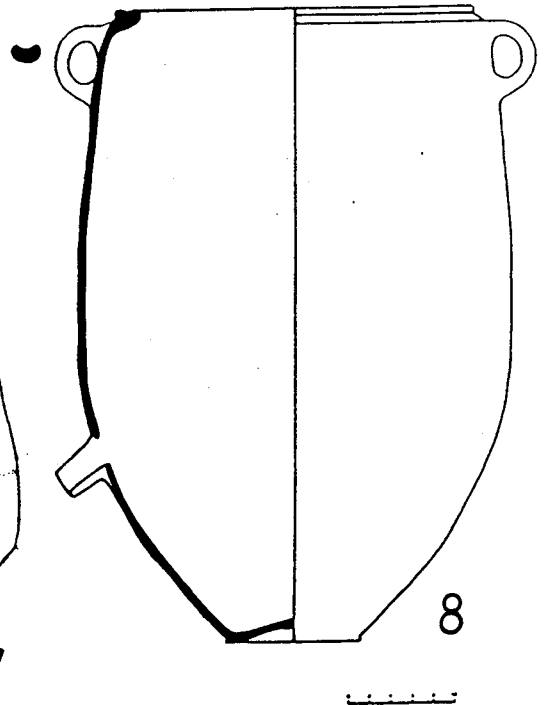
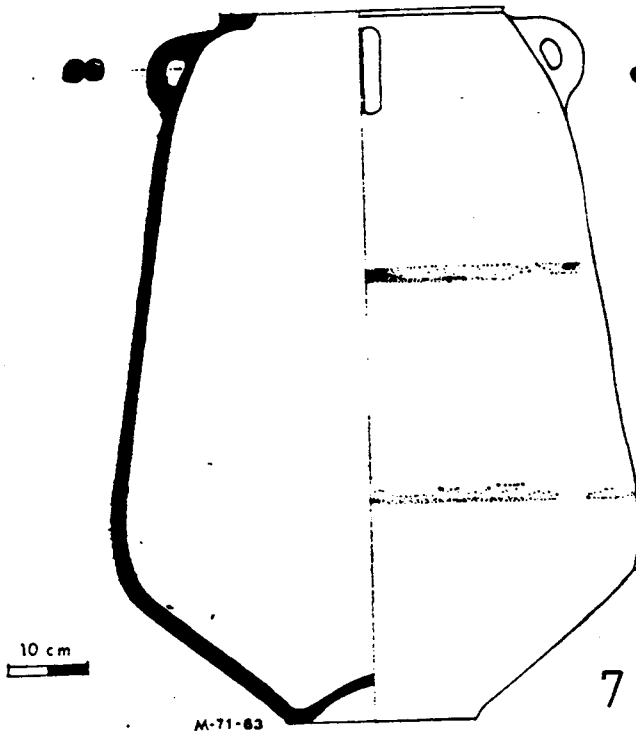
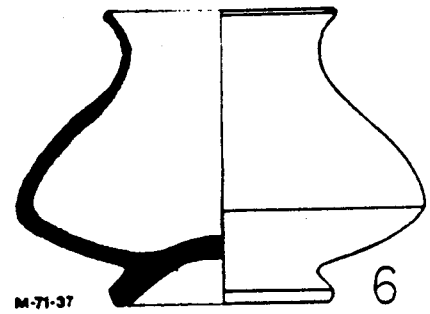
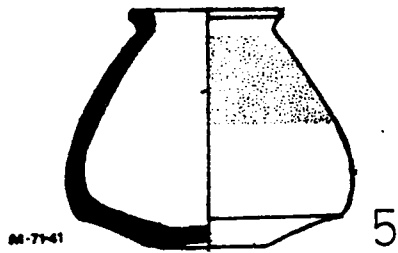
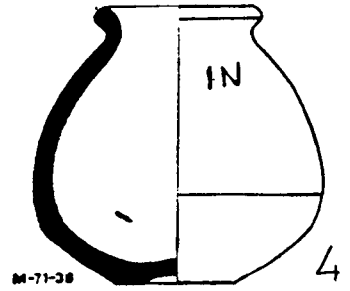
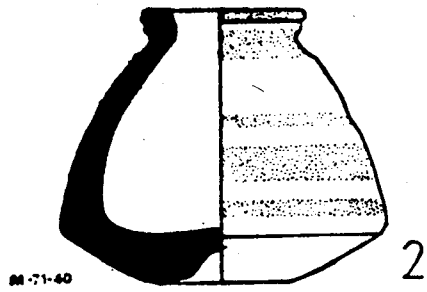
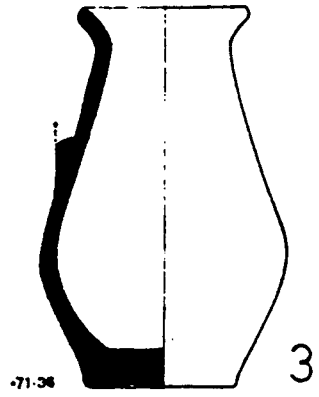
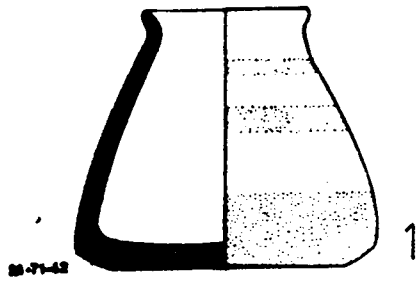
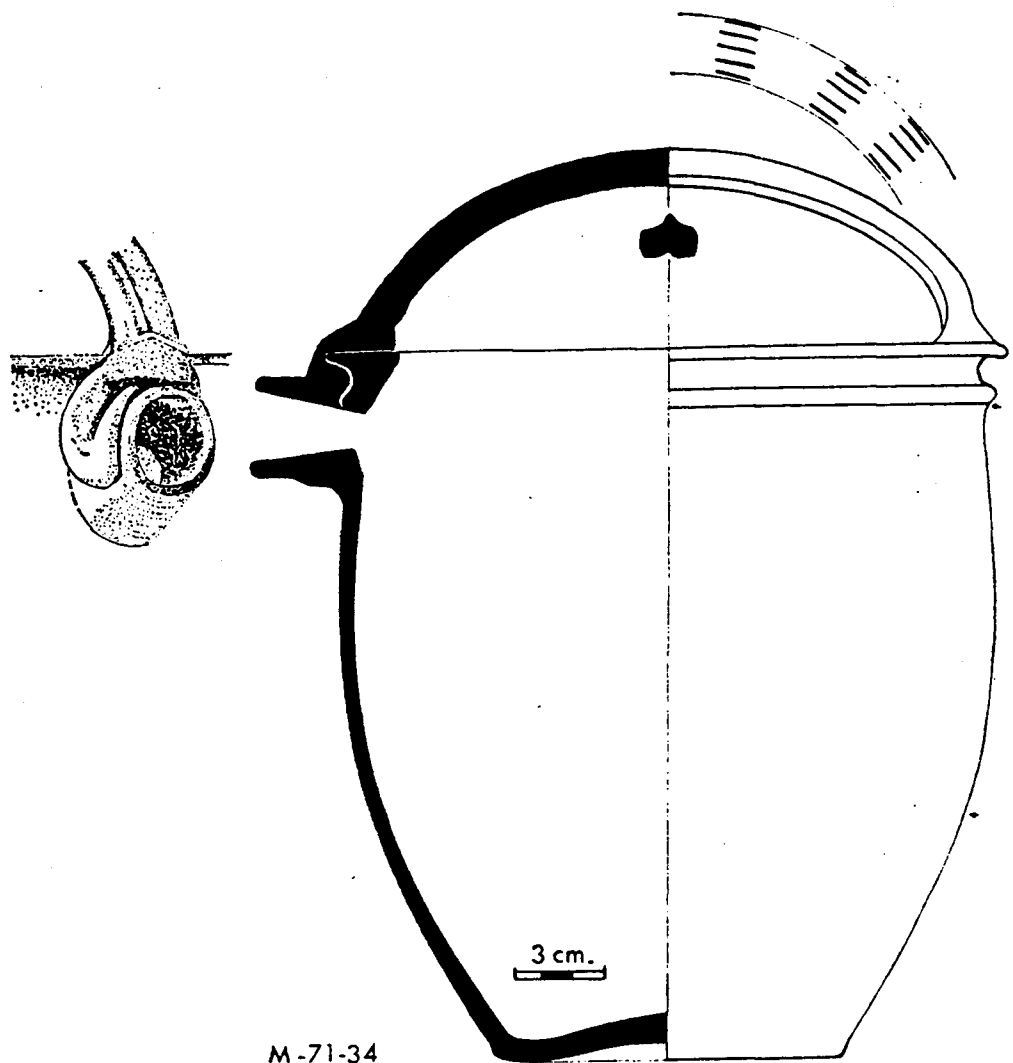

M-71-34



FIGURA 264



FIGURA 265

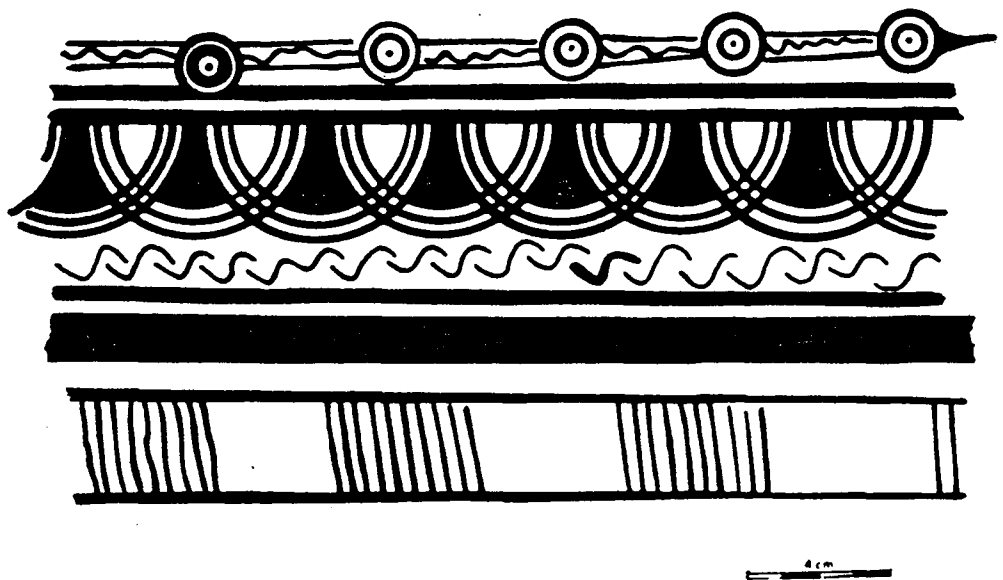

FIGURA 266

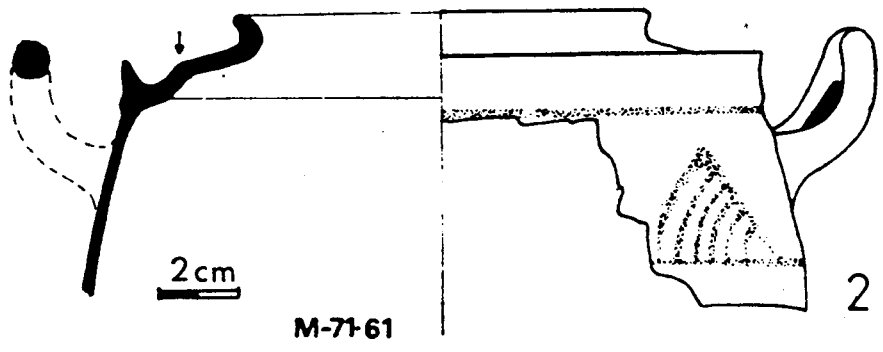
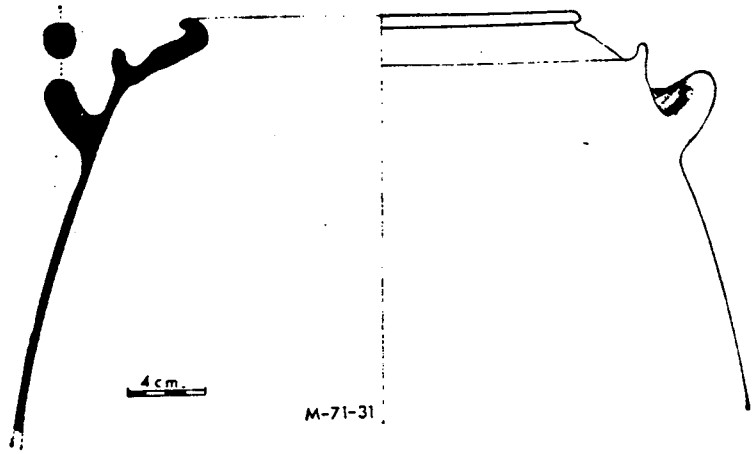

FIGURA 267

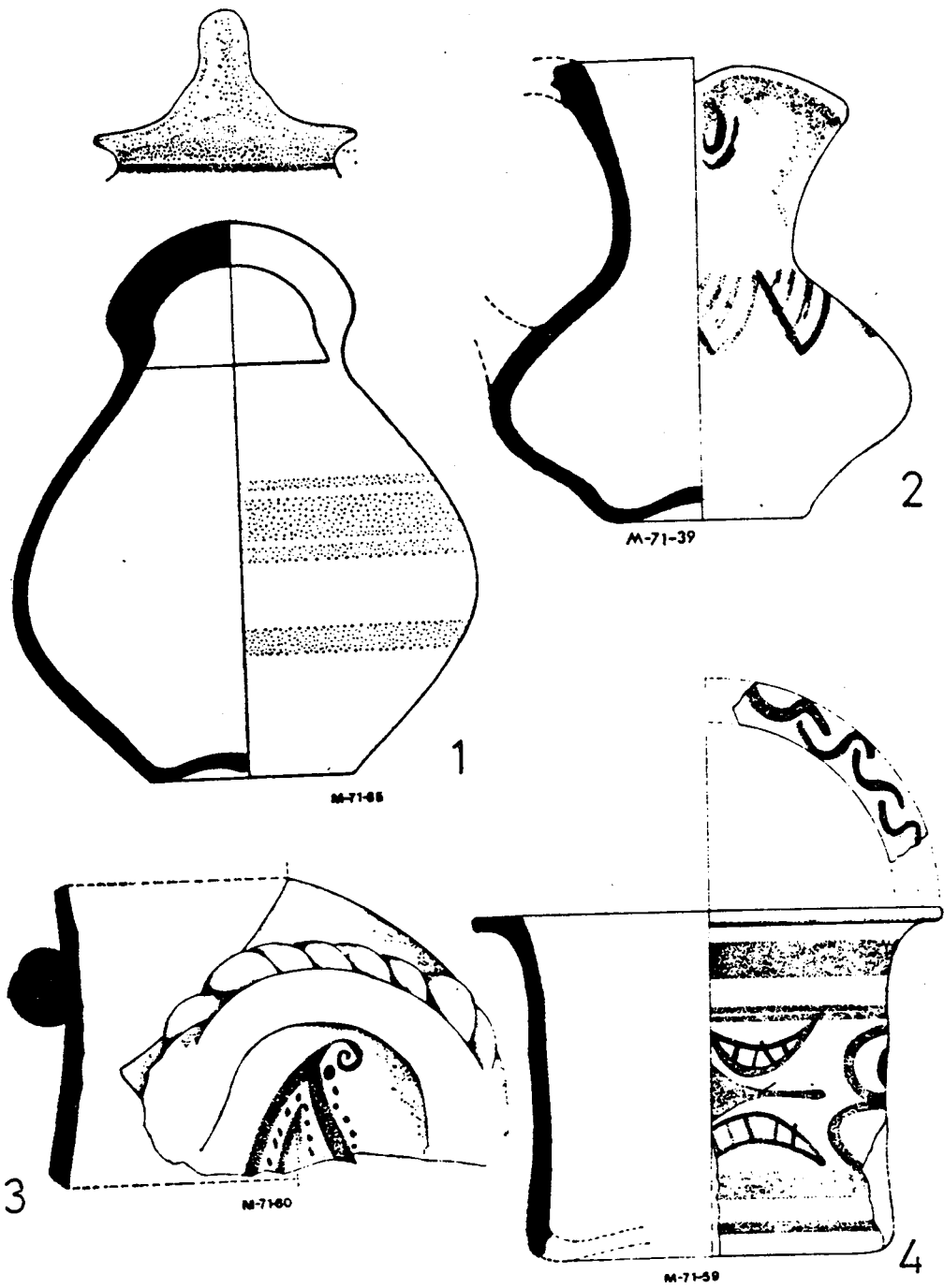

FIGURA 268

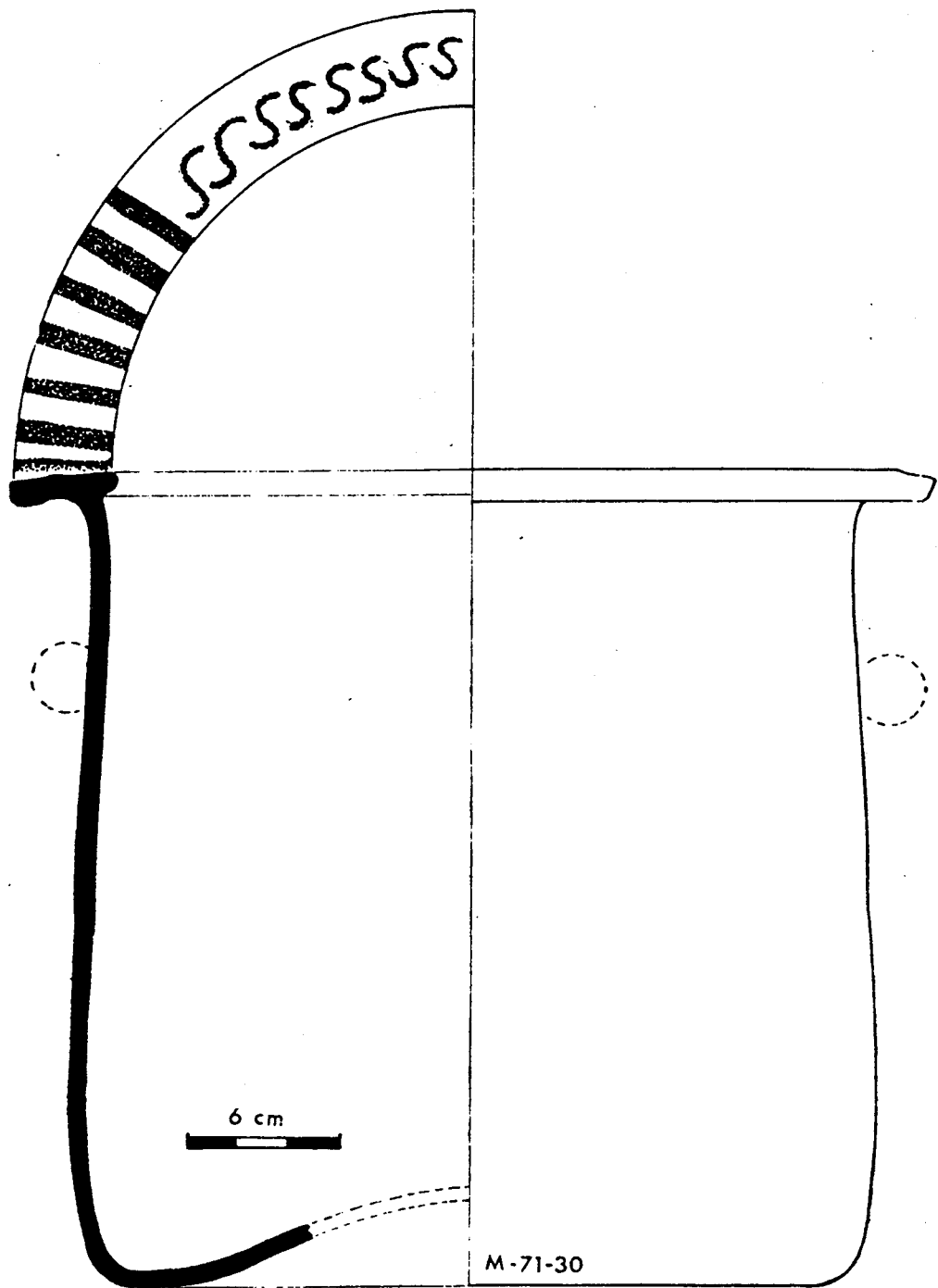

FIGURA 269

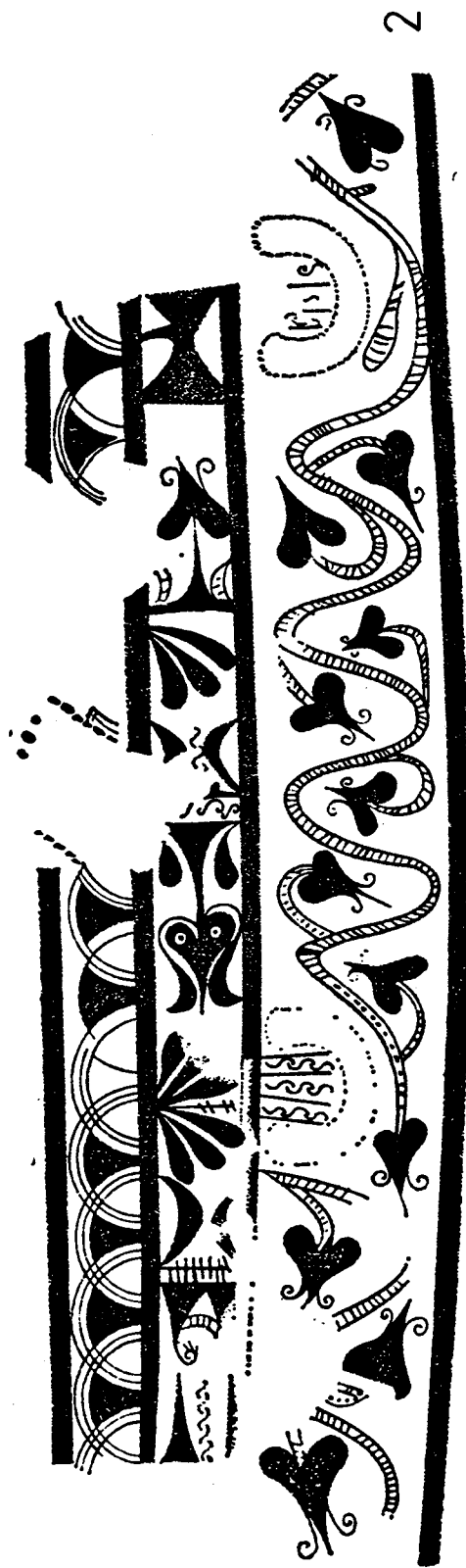
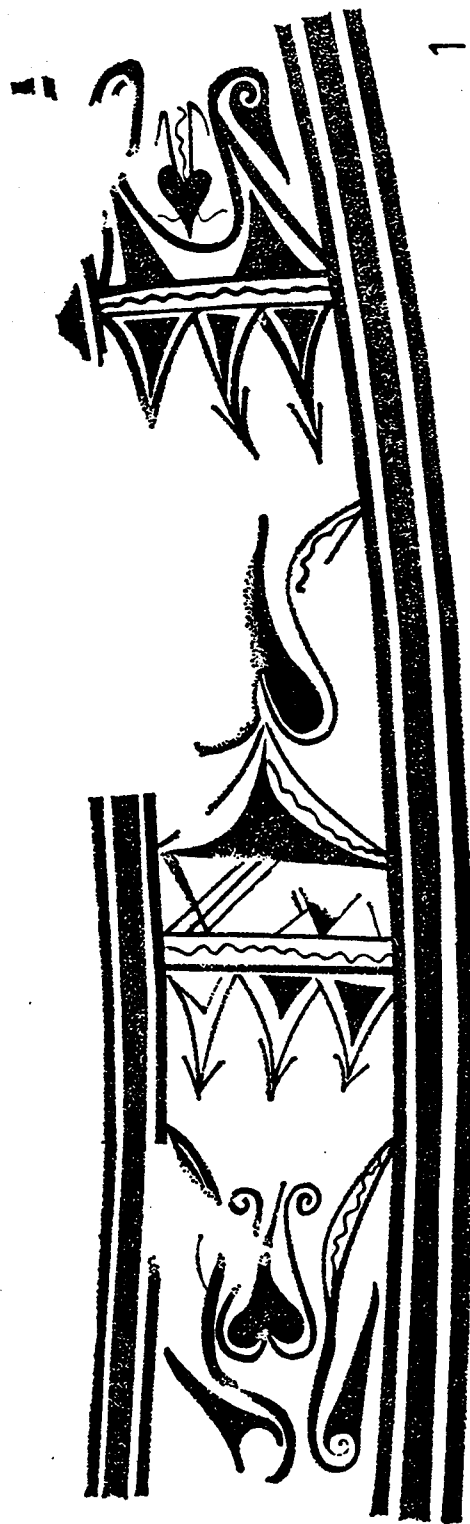

FIGURA 270

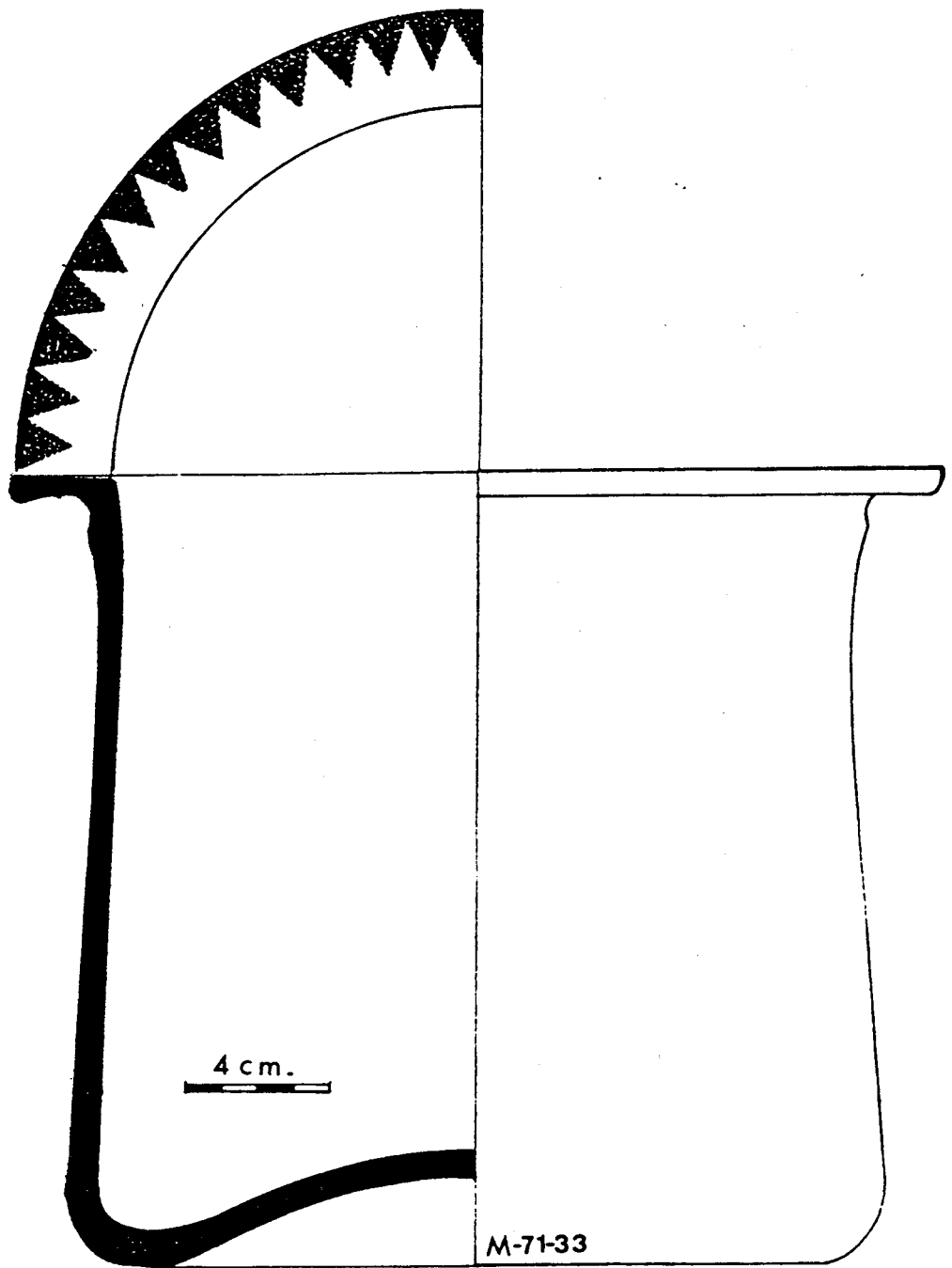

FIGURA 271

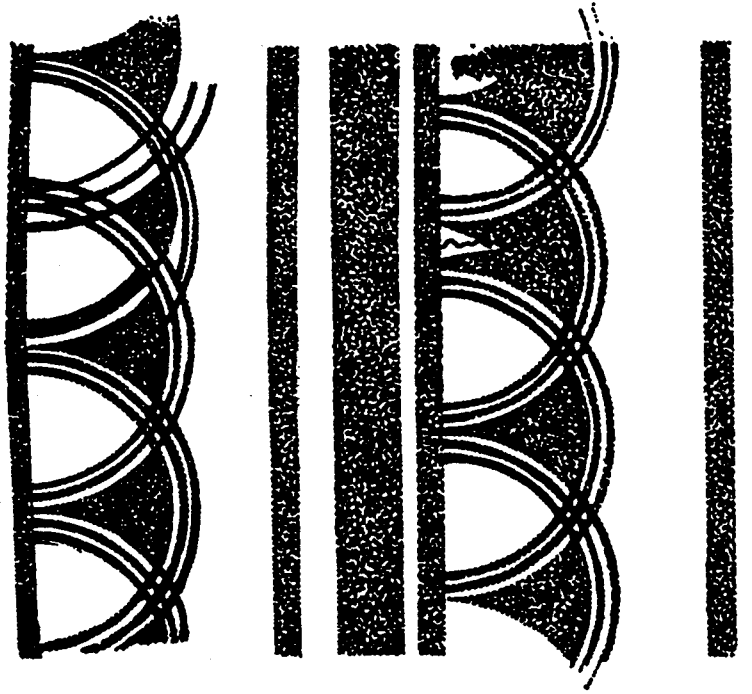
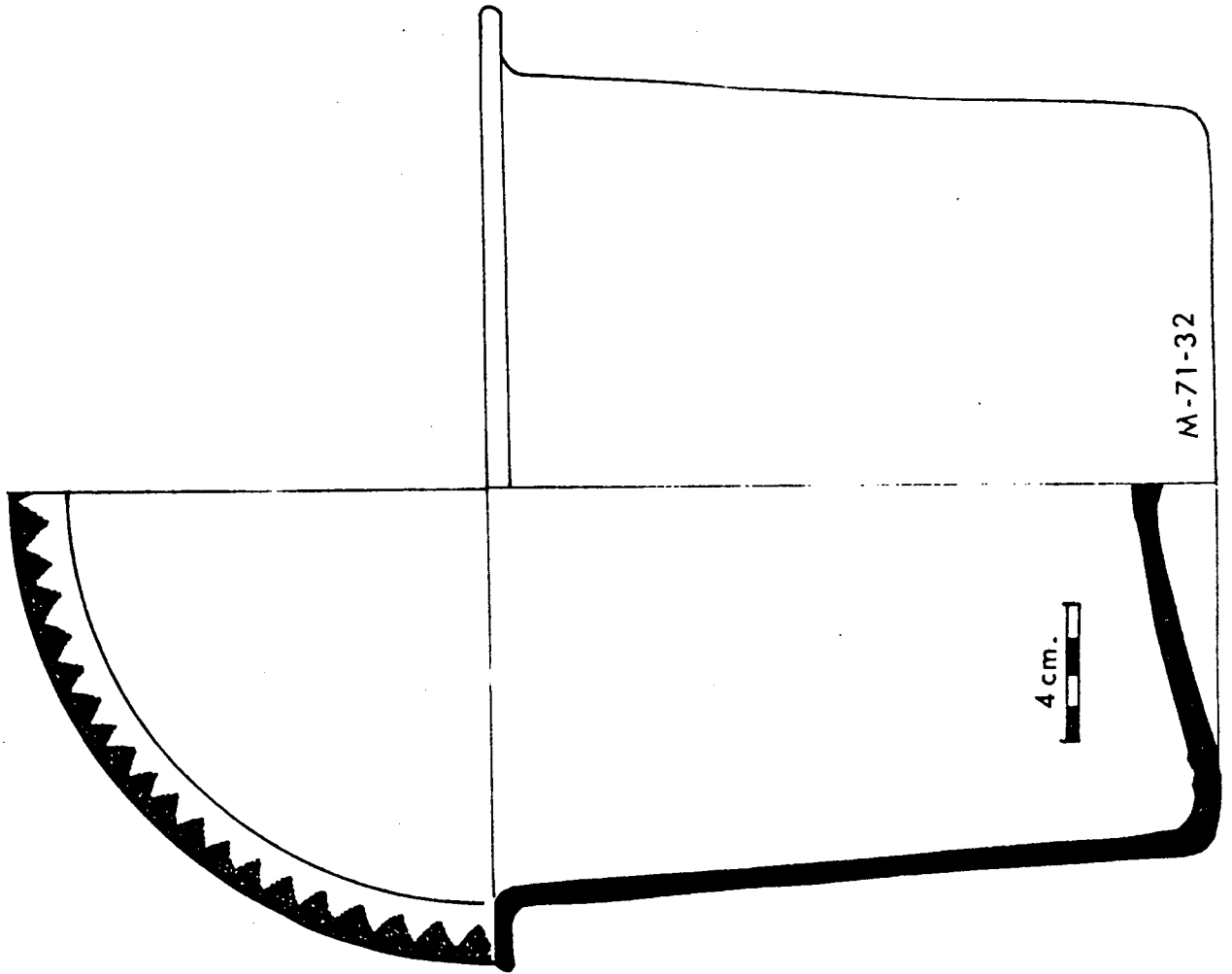

FIGURA 273

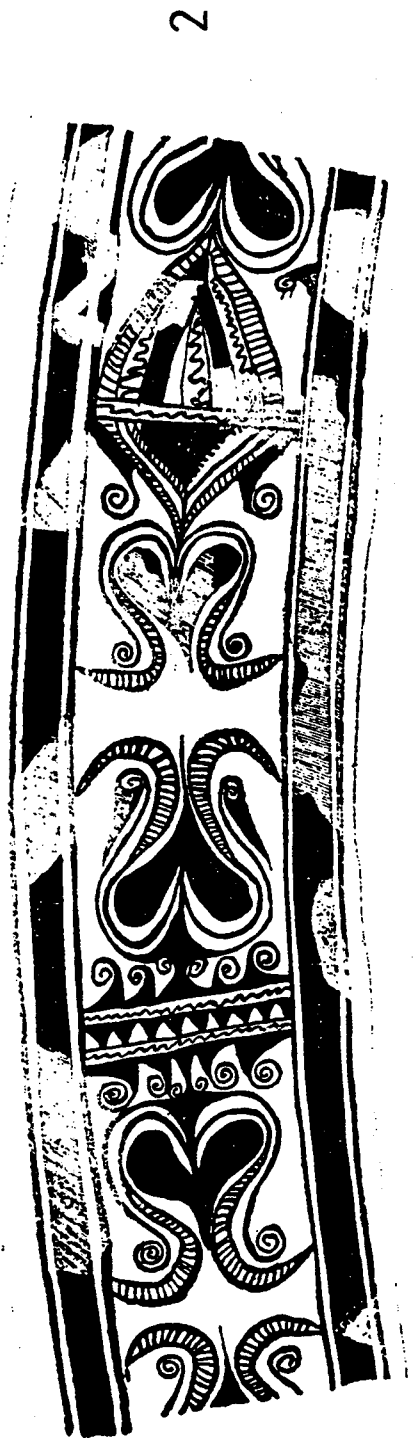
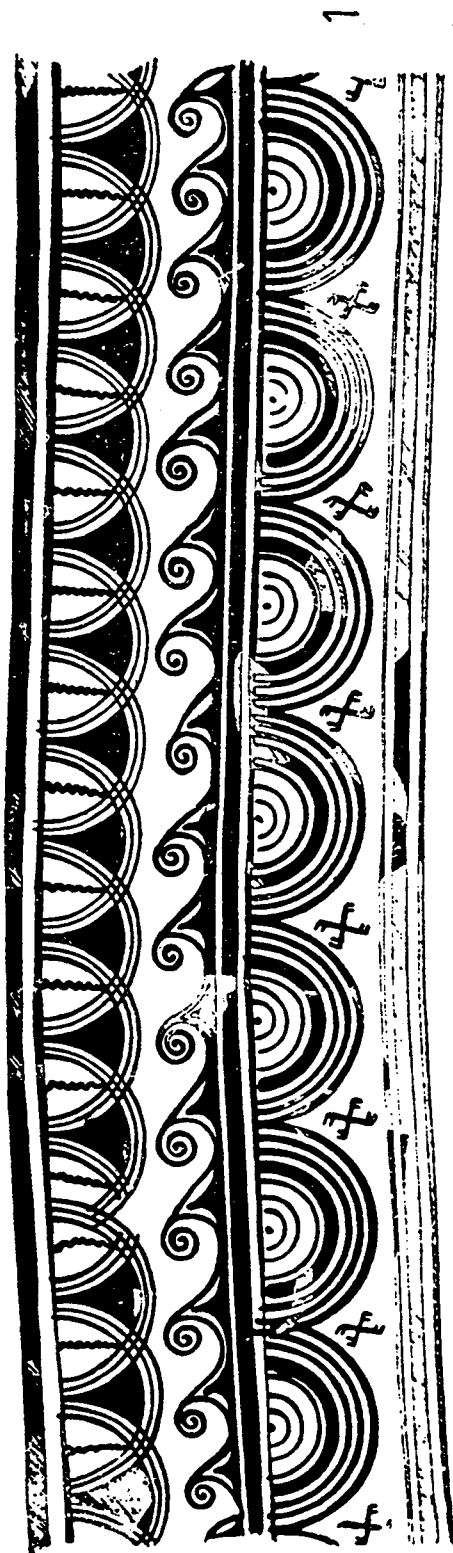

1

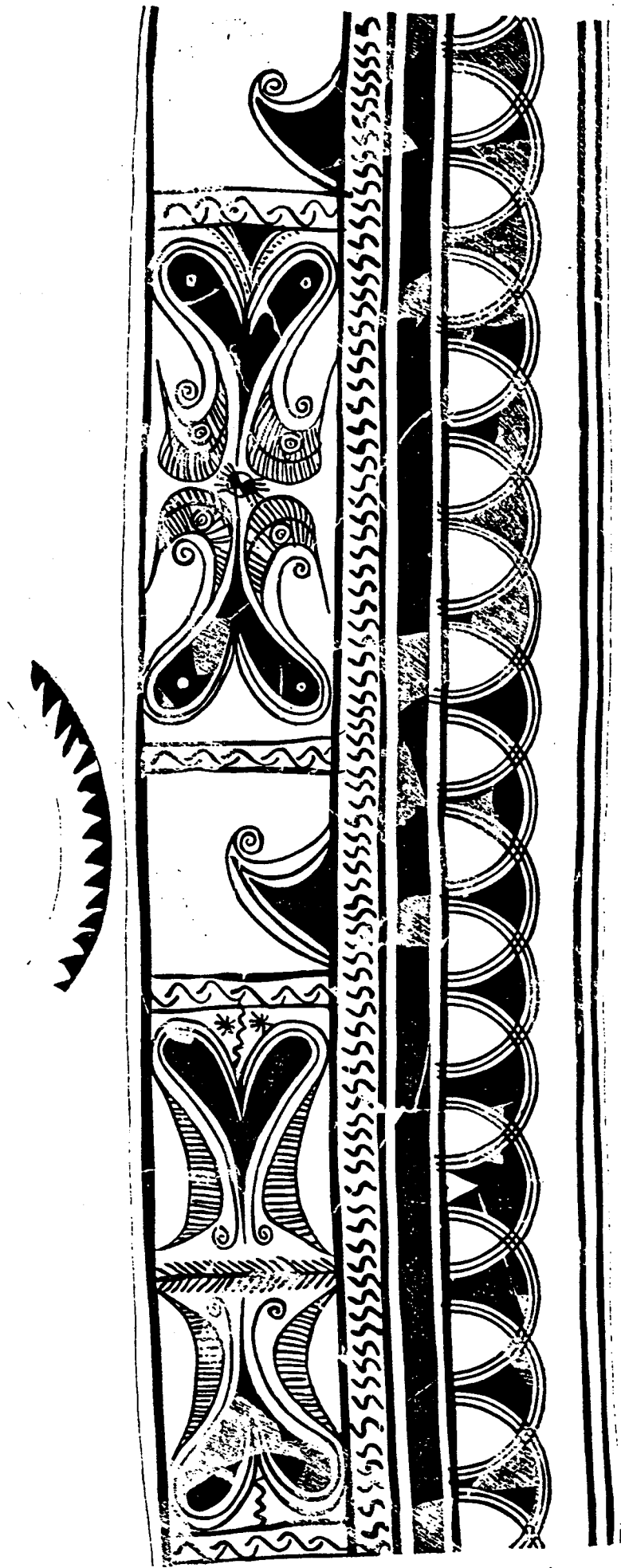
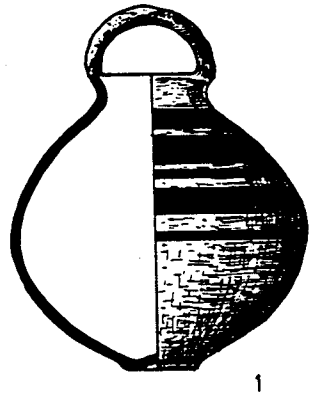
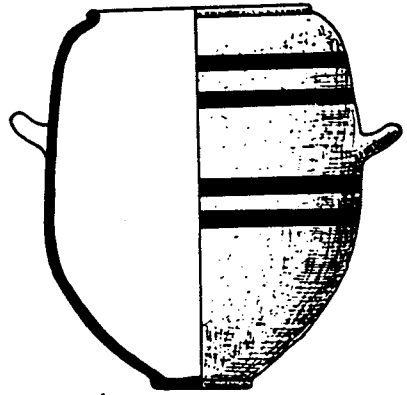

2

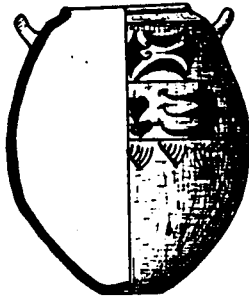

3

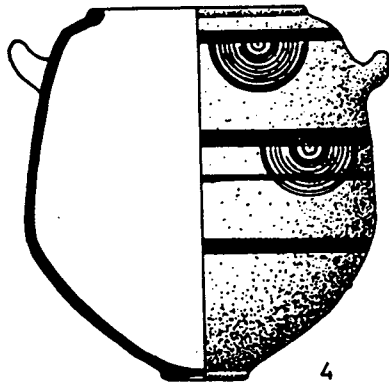

4

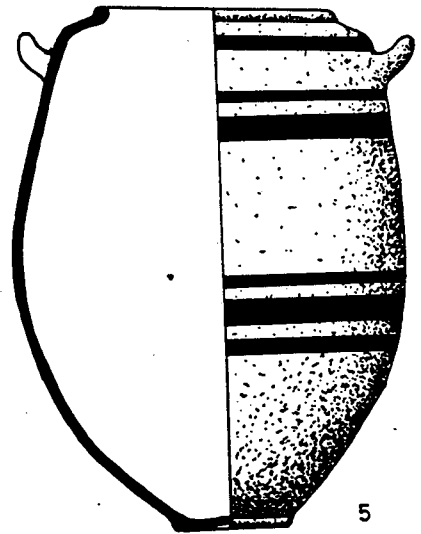

5

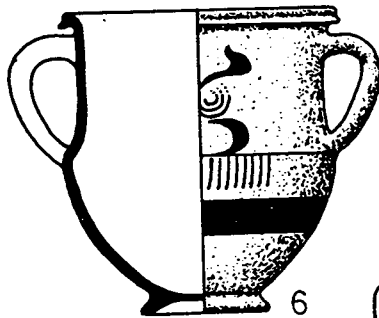

6



7

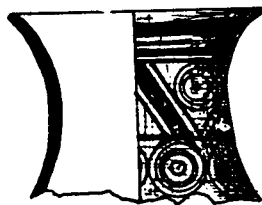

8

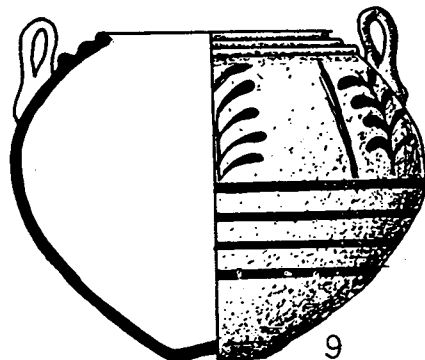

9

FIGURA 274

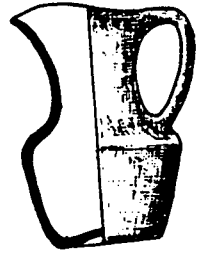

1



2



3

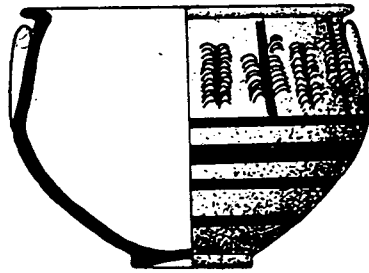

4

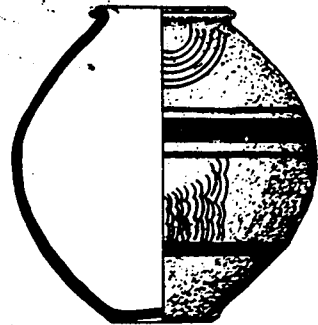

5

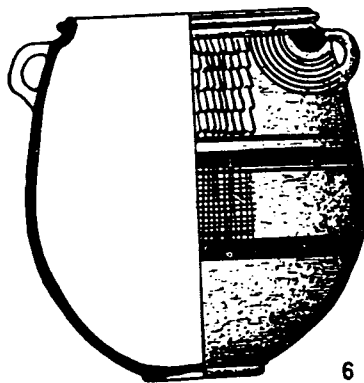

6

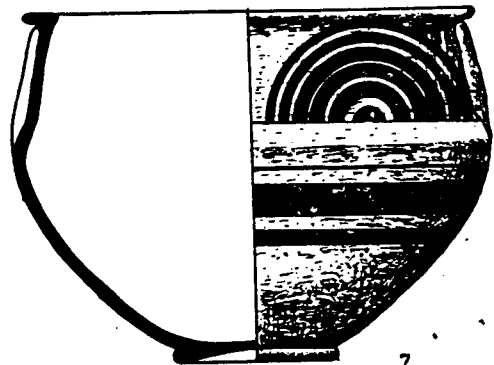

7

FIGURA 275



FIGURA 276



FIGURA 277

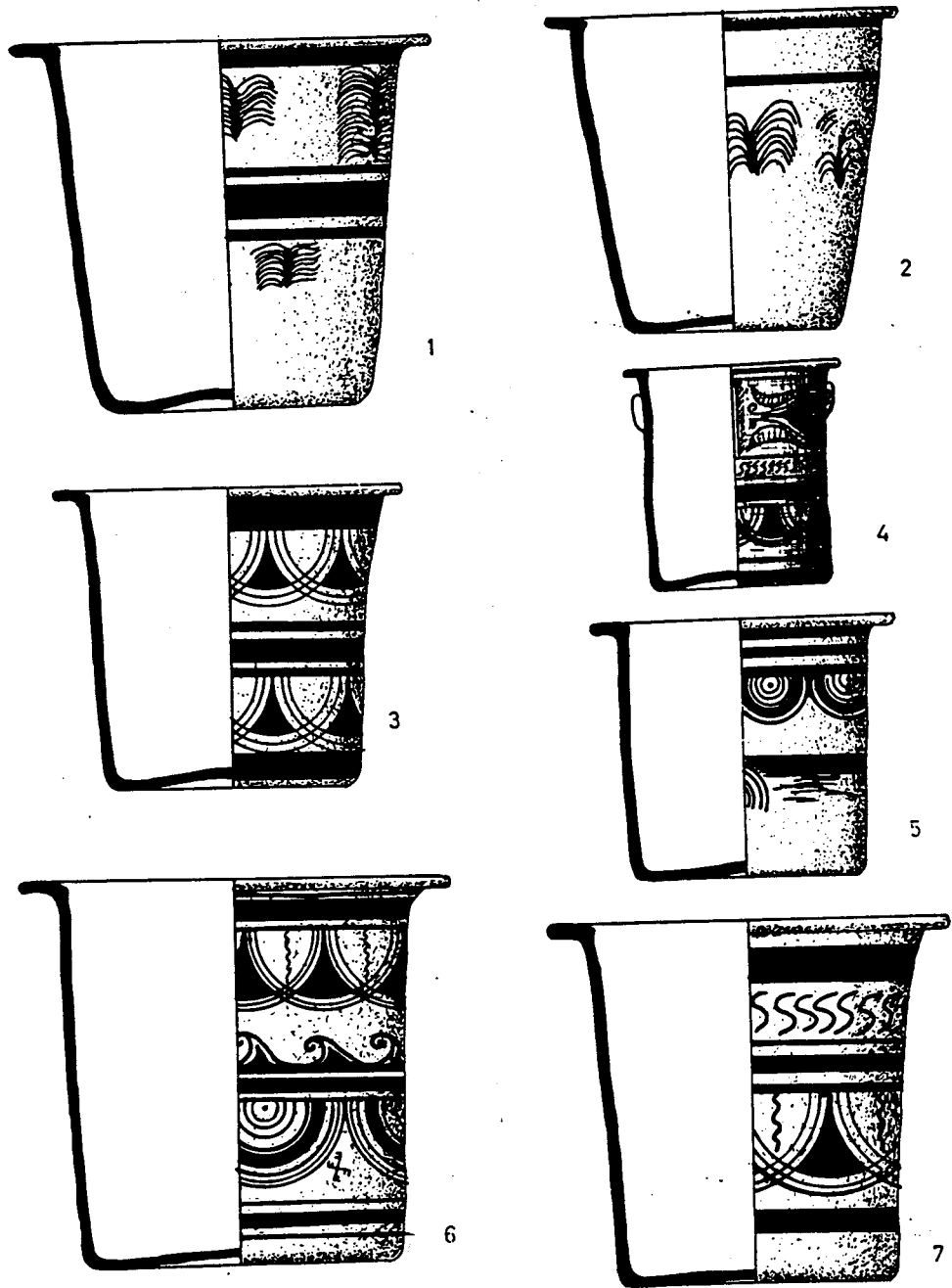

FIGURA 278

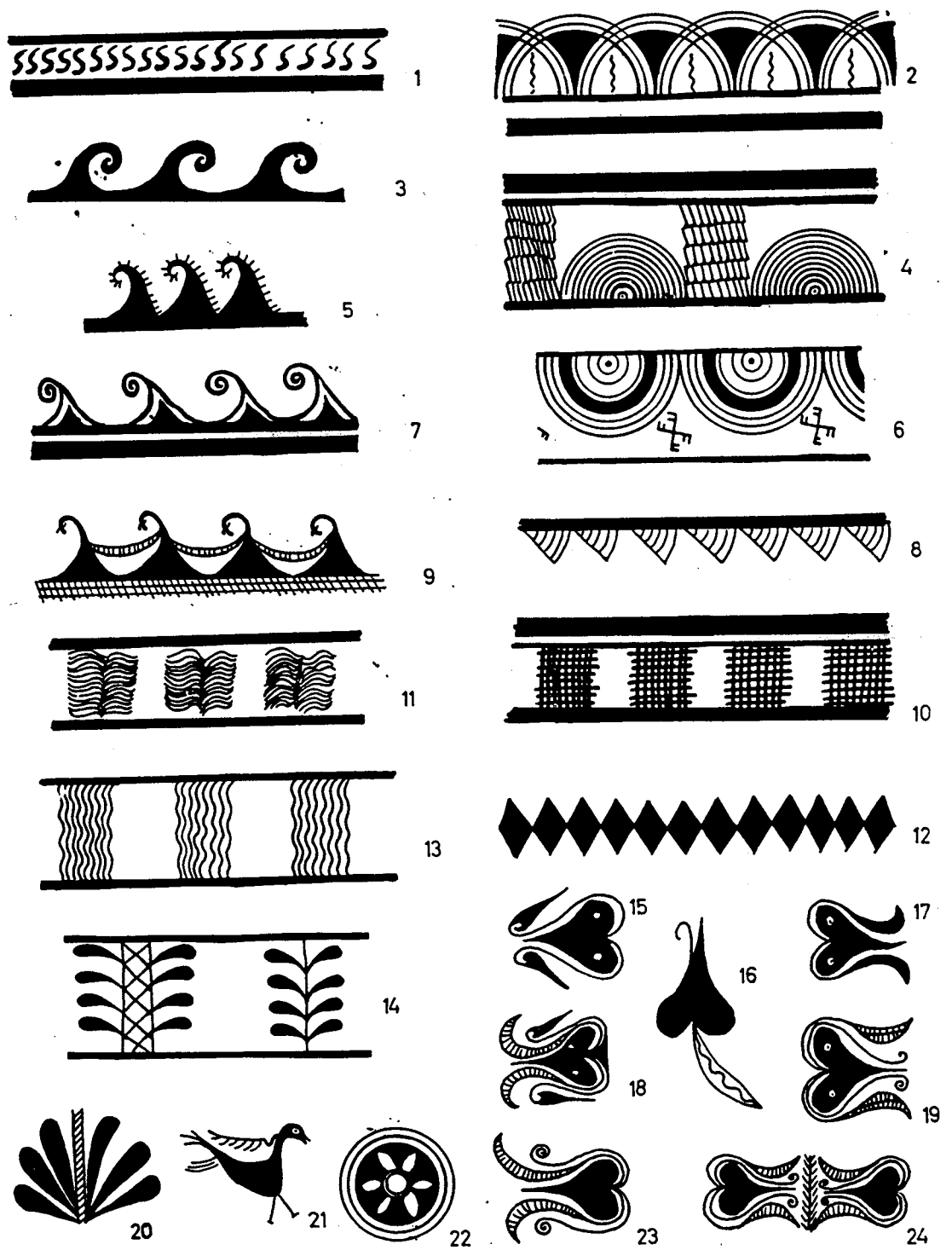

FIGURA 279

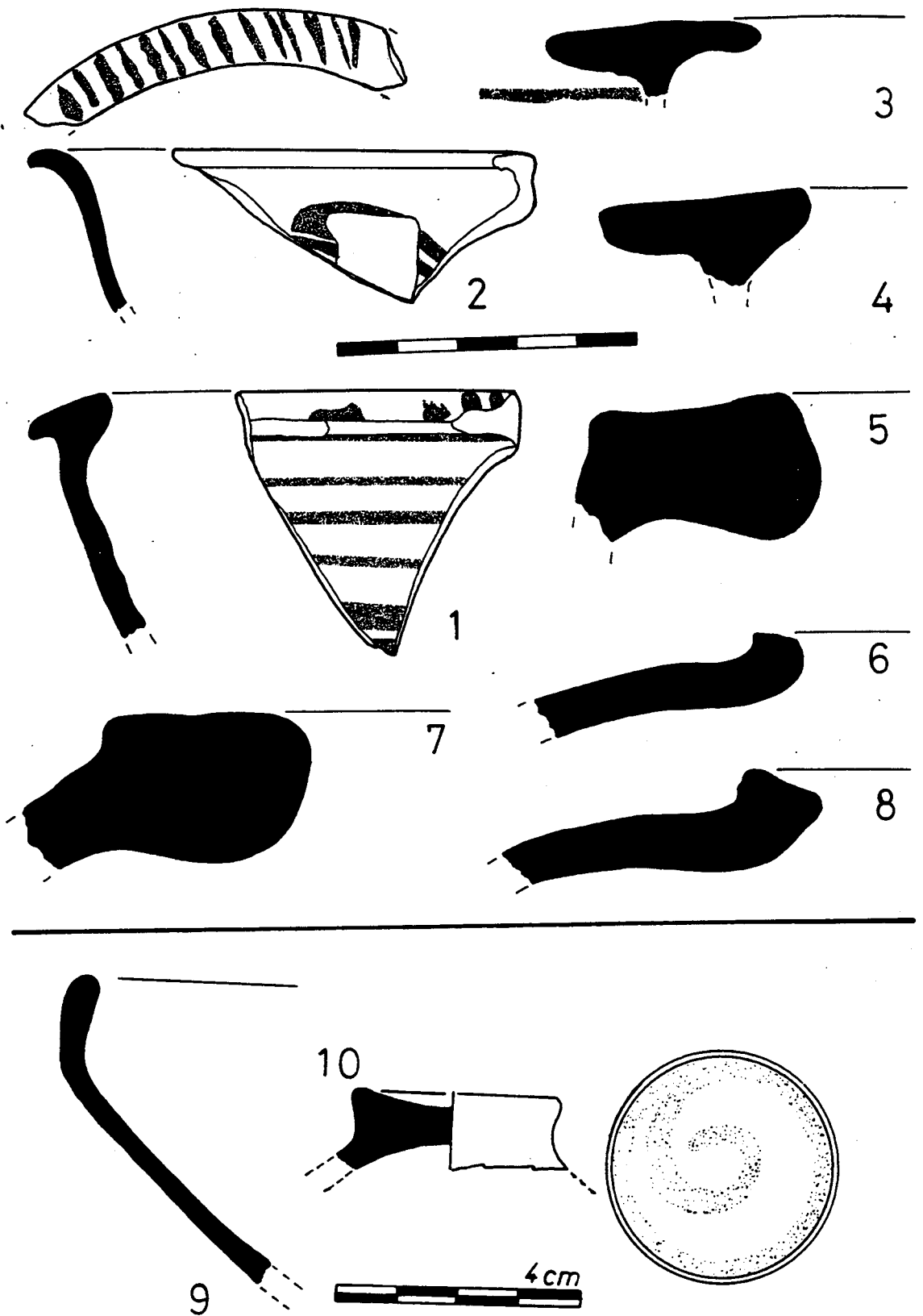

FIGURA 280

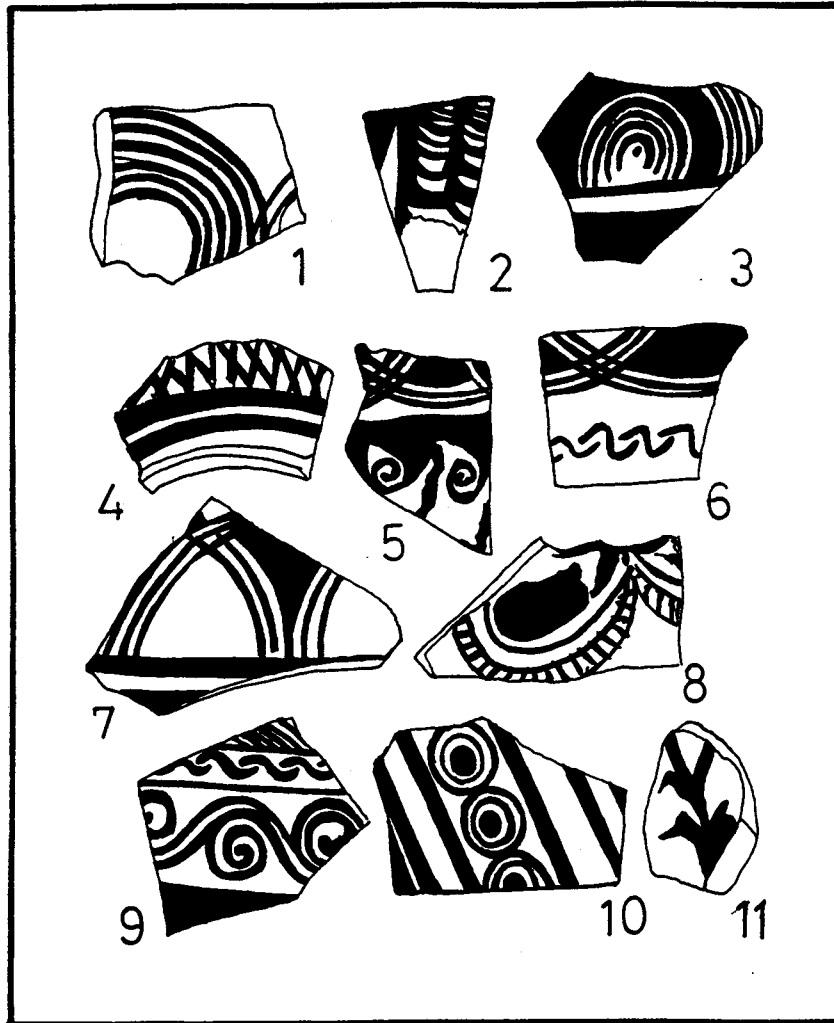

1

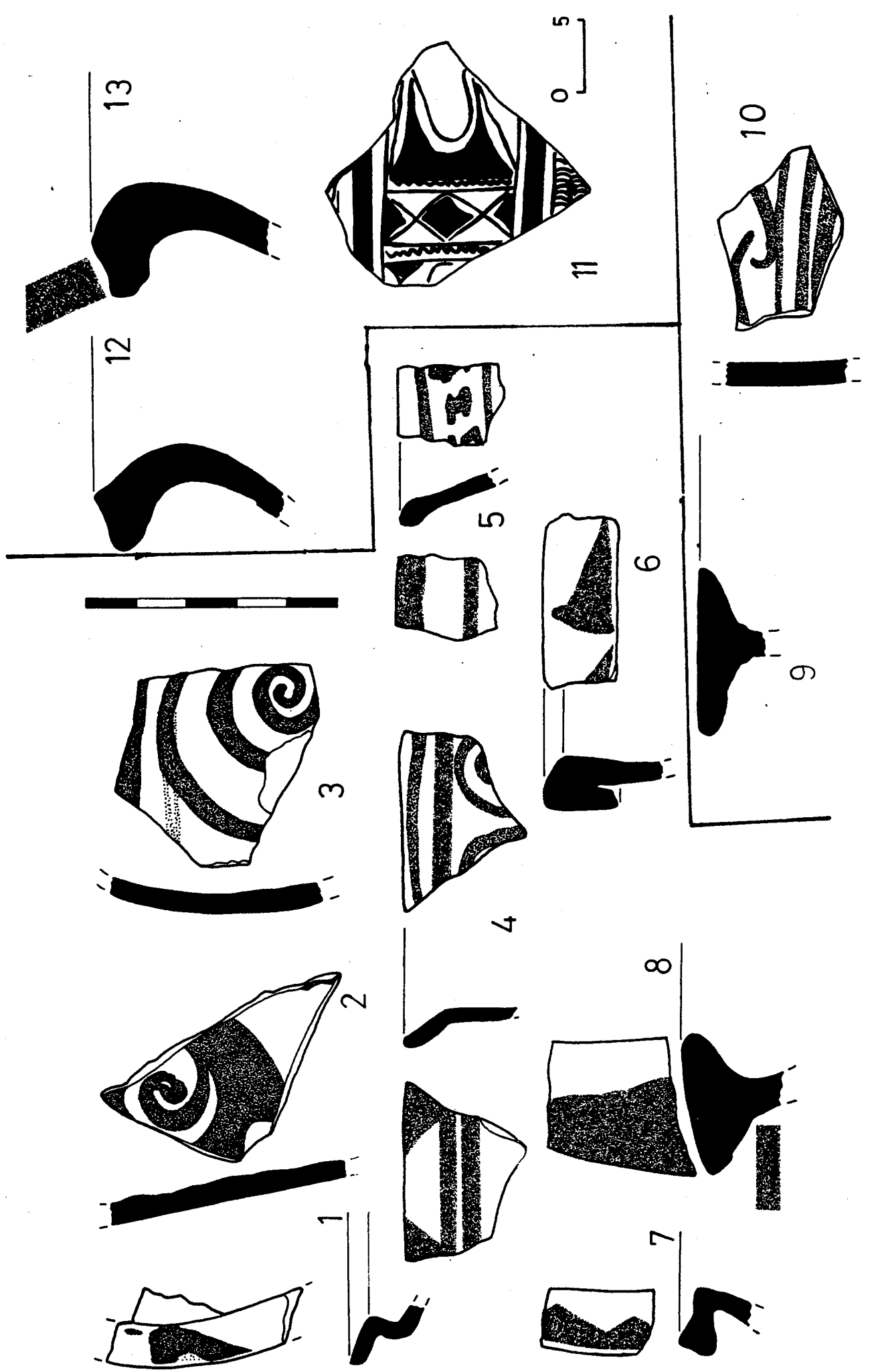
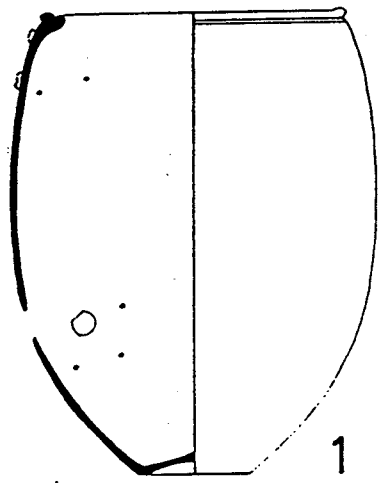
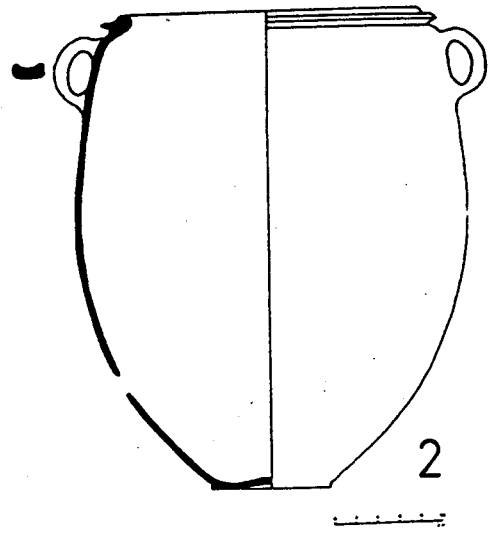

2

FIGURE 5. Moli d'Espigol.

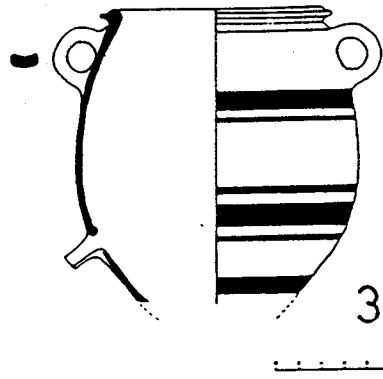

3

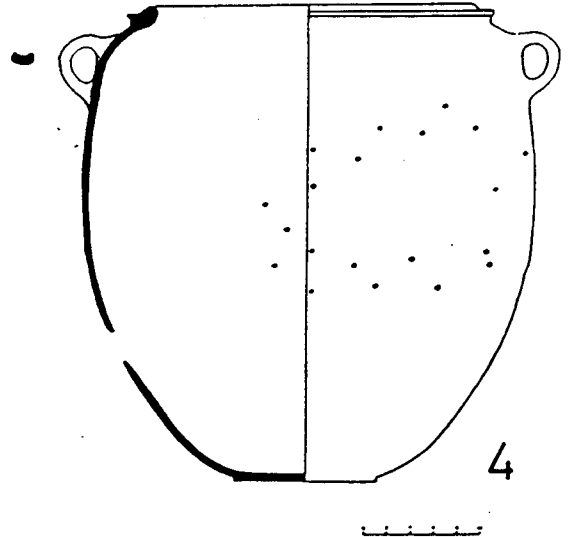

4

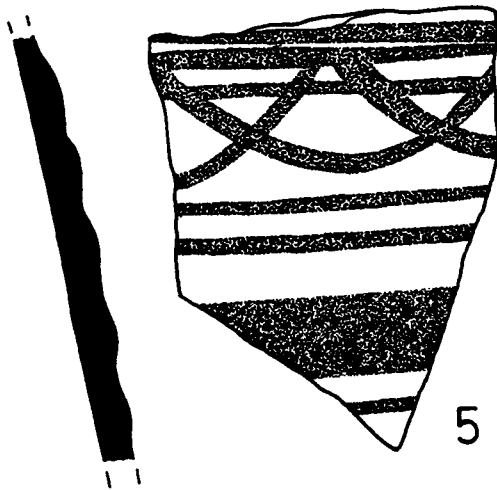

5

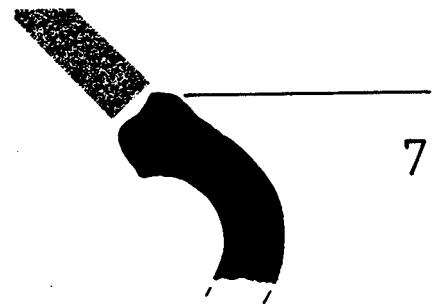

7



6

FIGURA 281



FIGURA 282



FIGURA 283

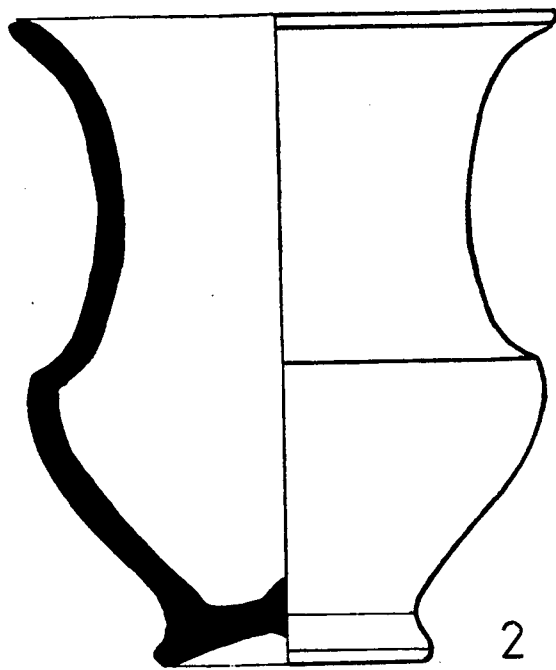
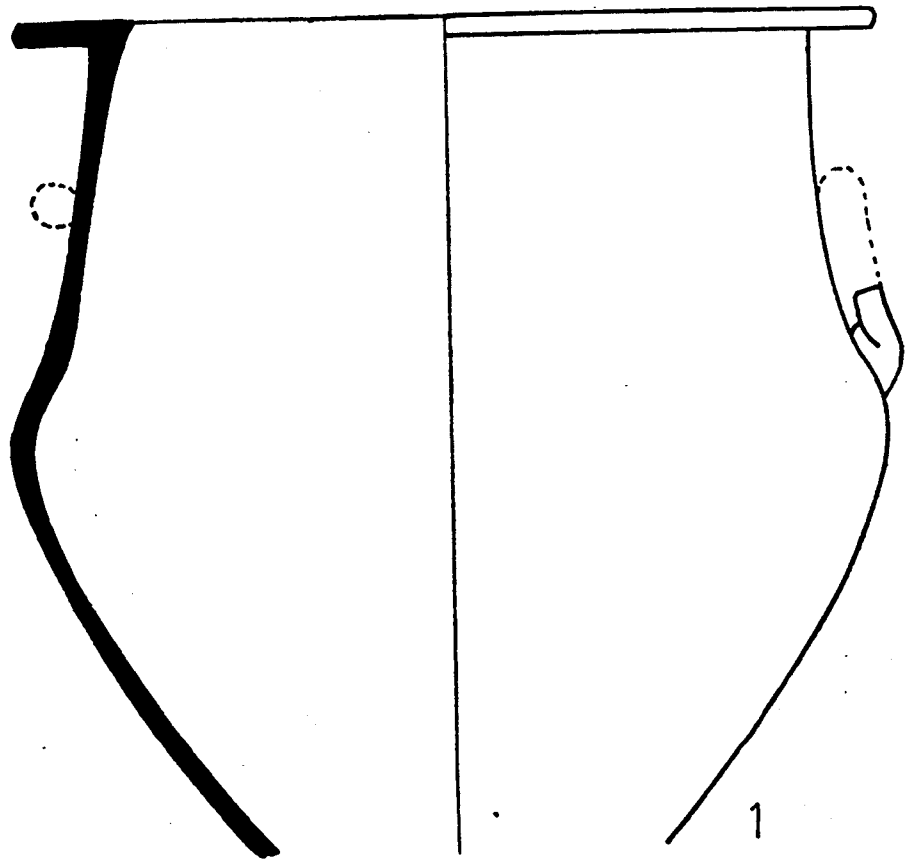

FIGURA 284

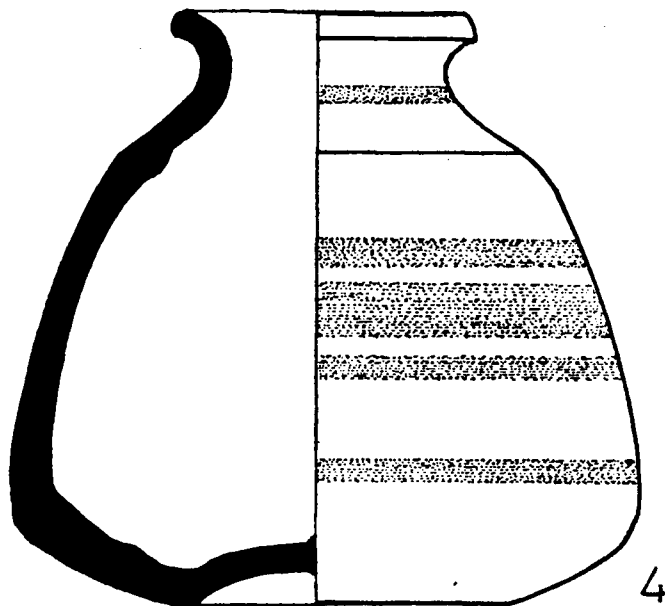
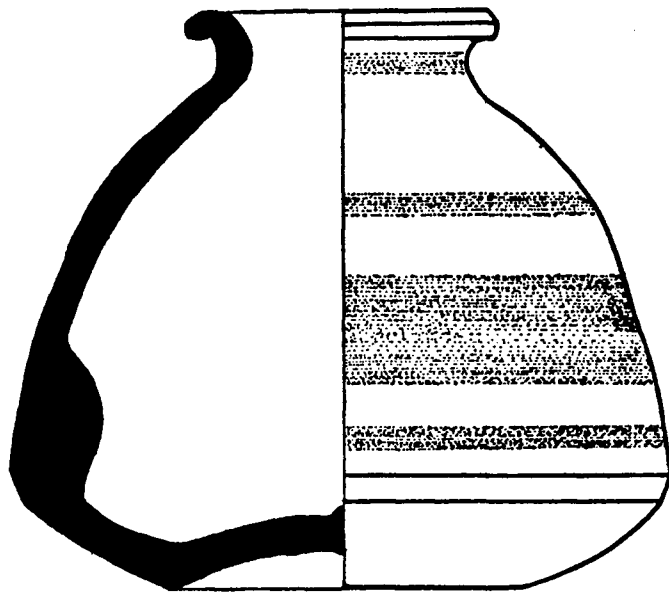
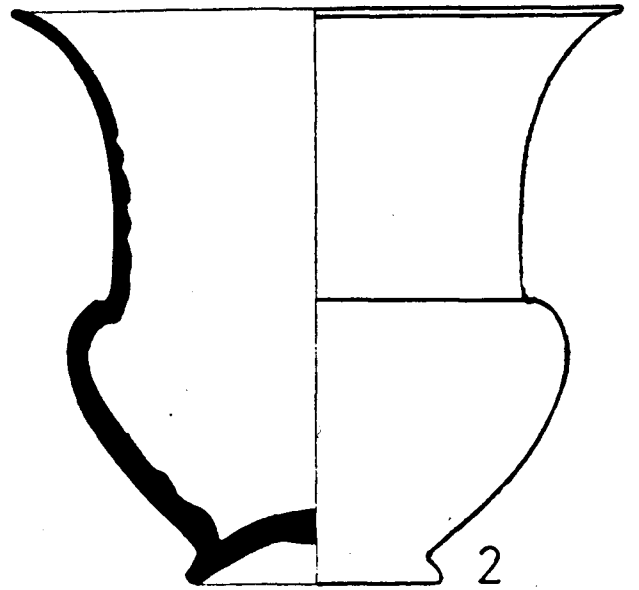
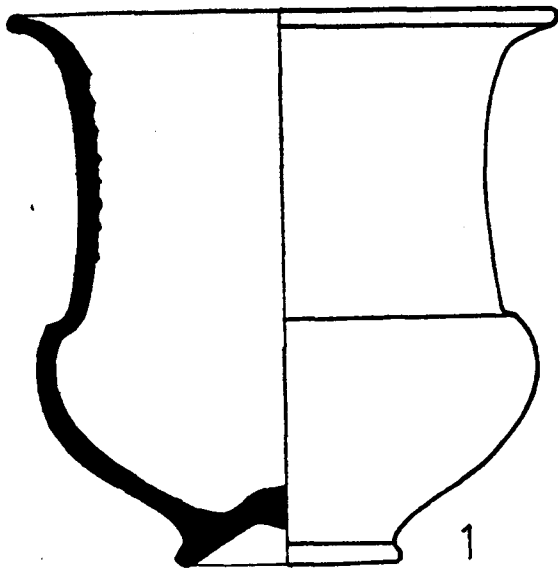

1

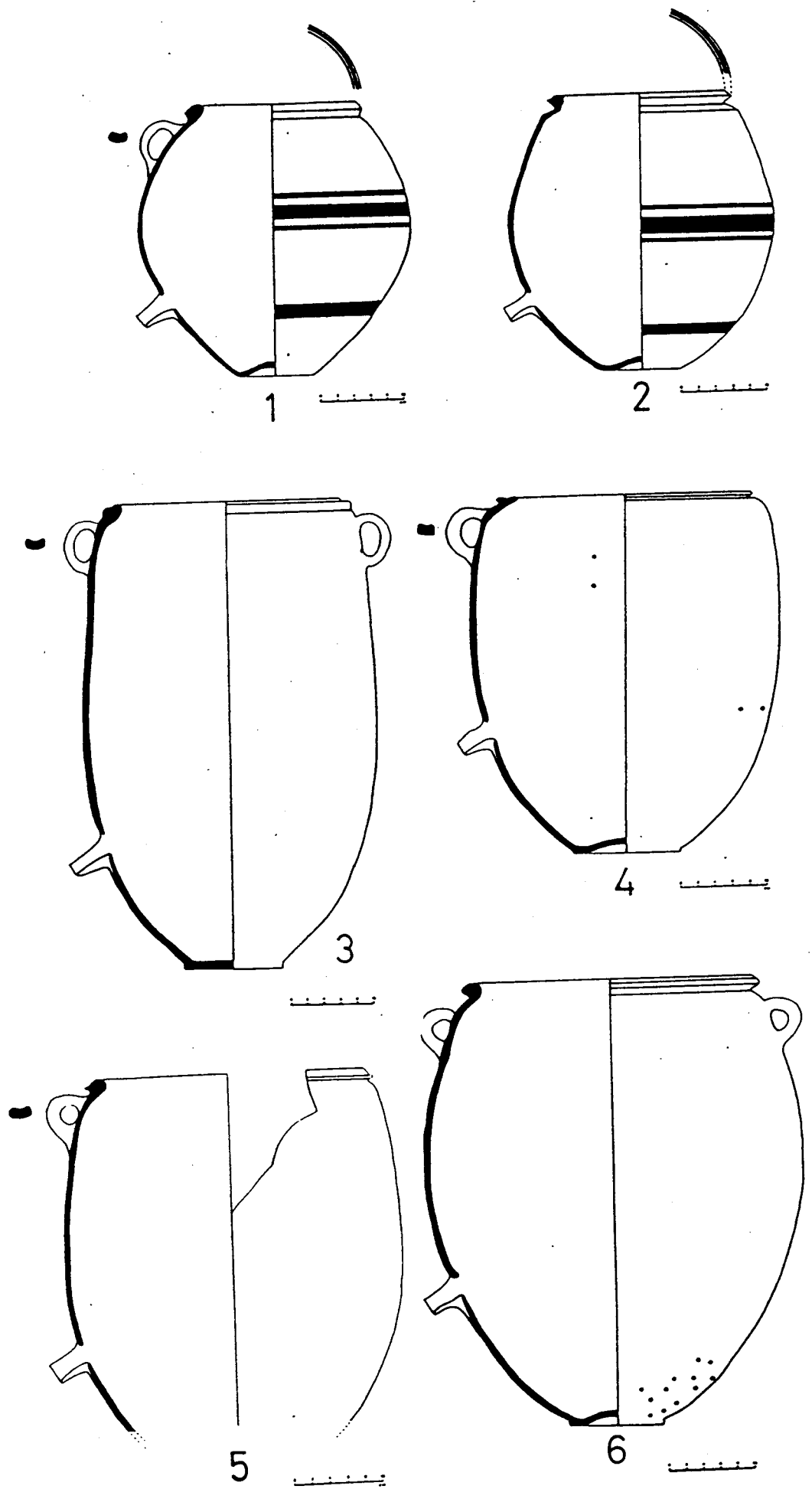
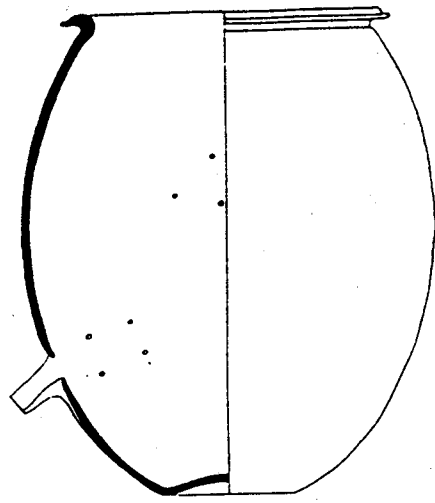
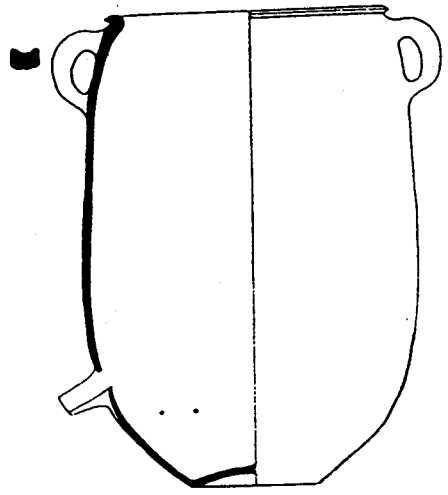
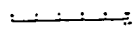

2

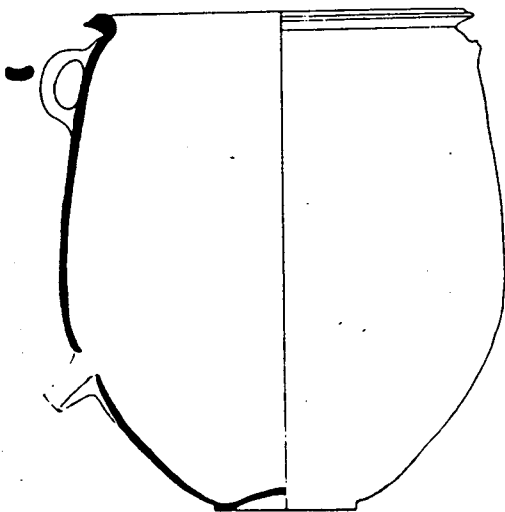
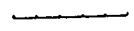

3

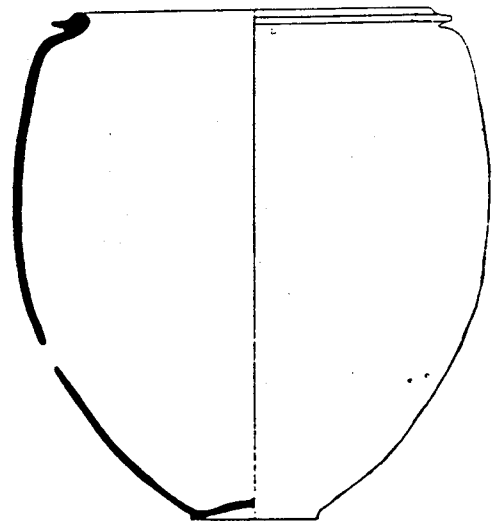
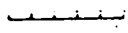

4

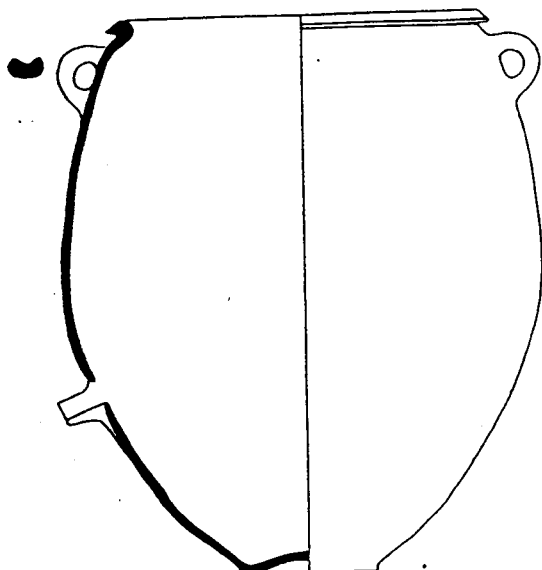

5

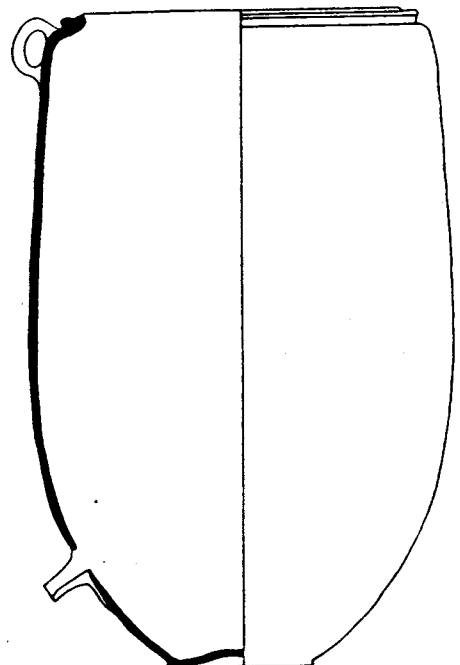

6



FIGURA 285



FIGURA 286



FIGURA 287

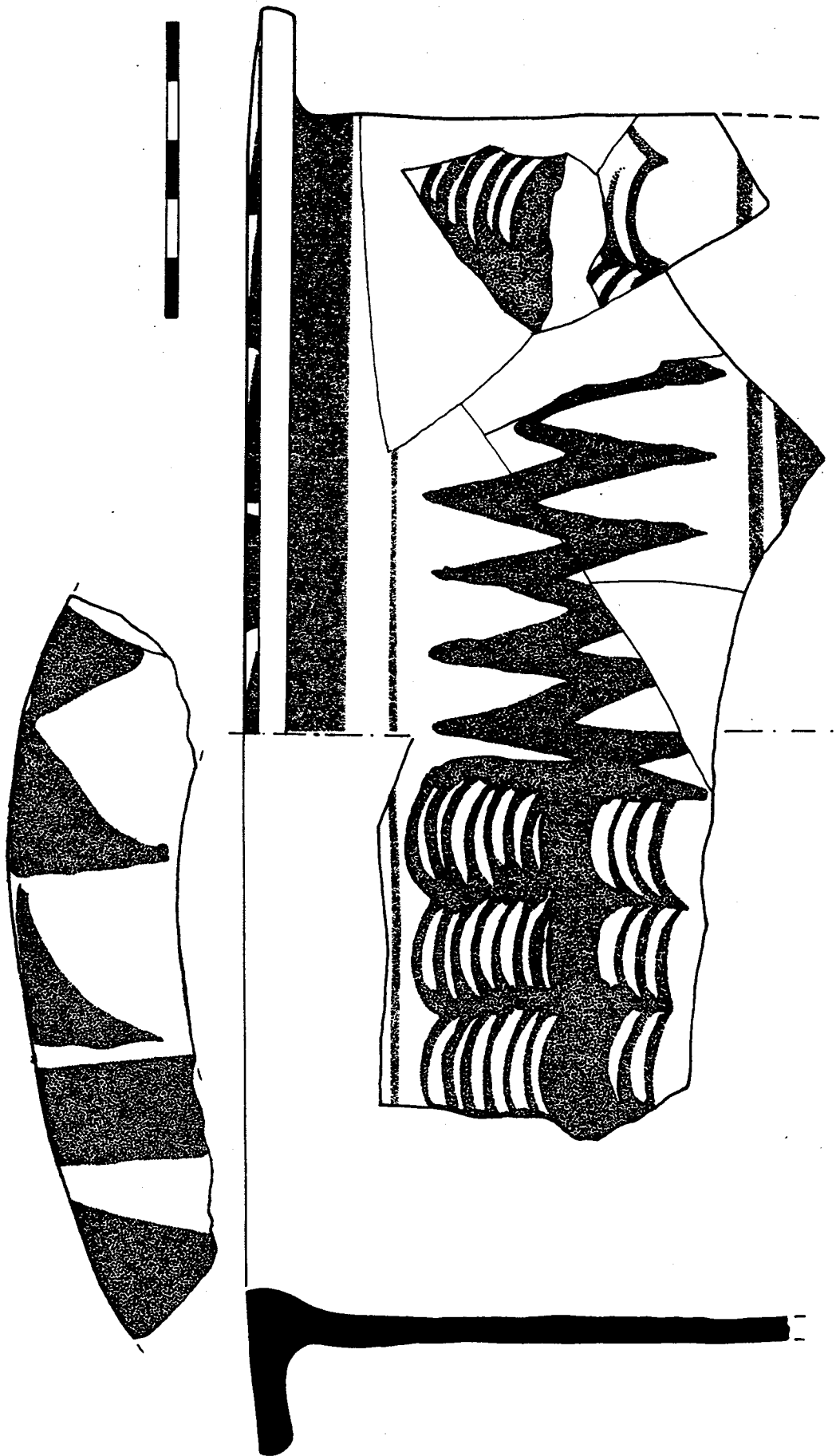

FIGURA 288

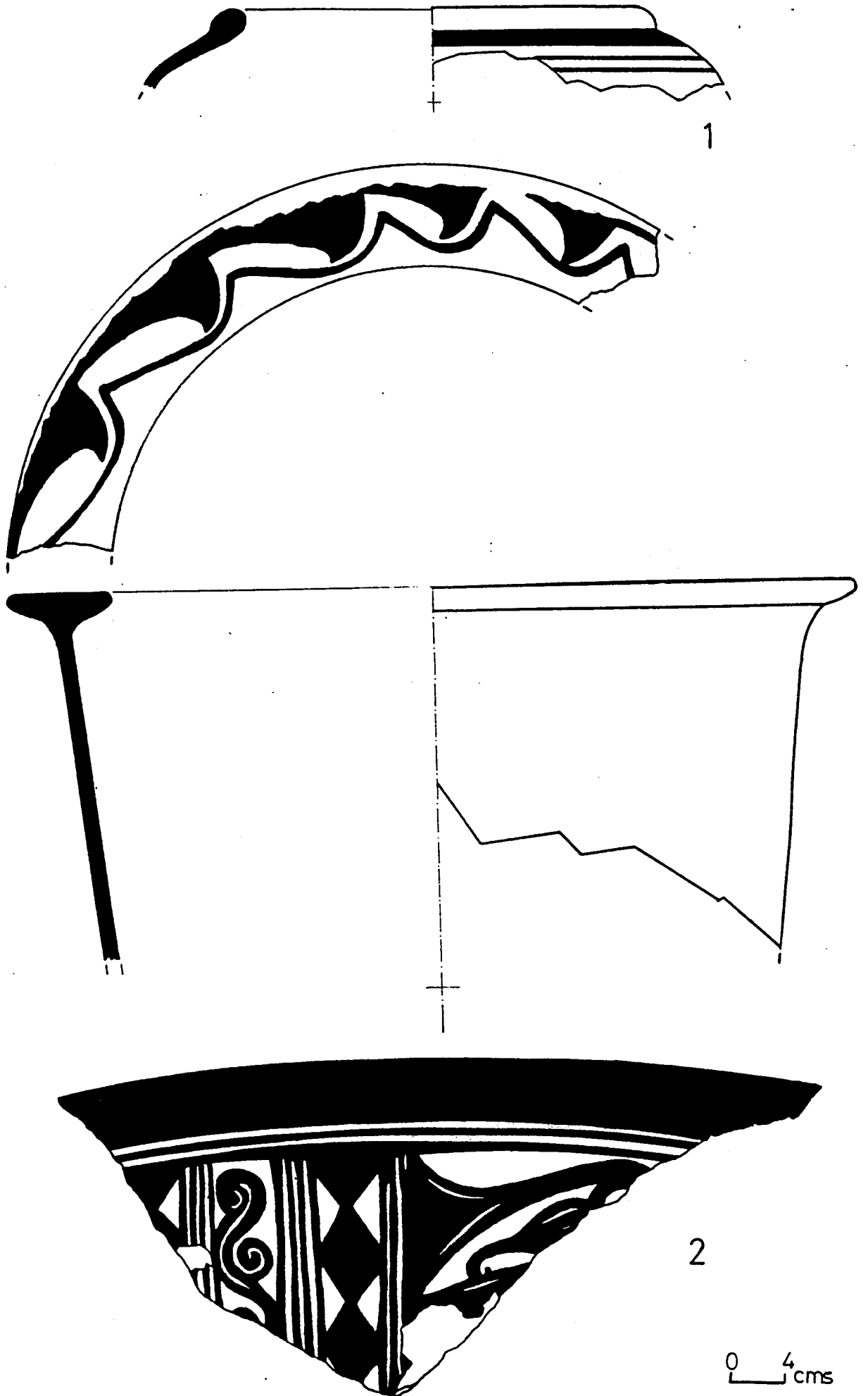

FIGURA 289

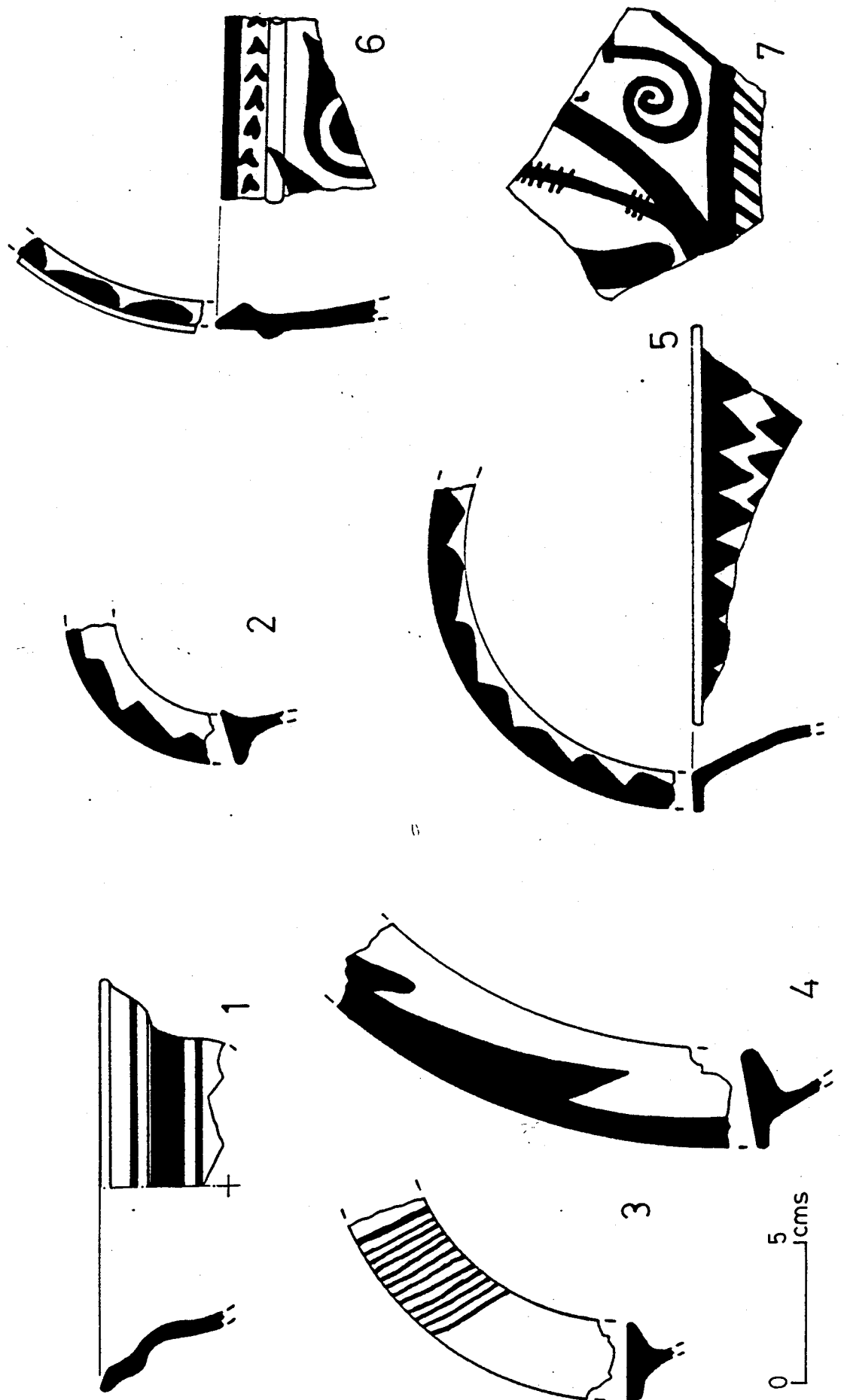

FIGURA 290

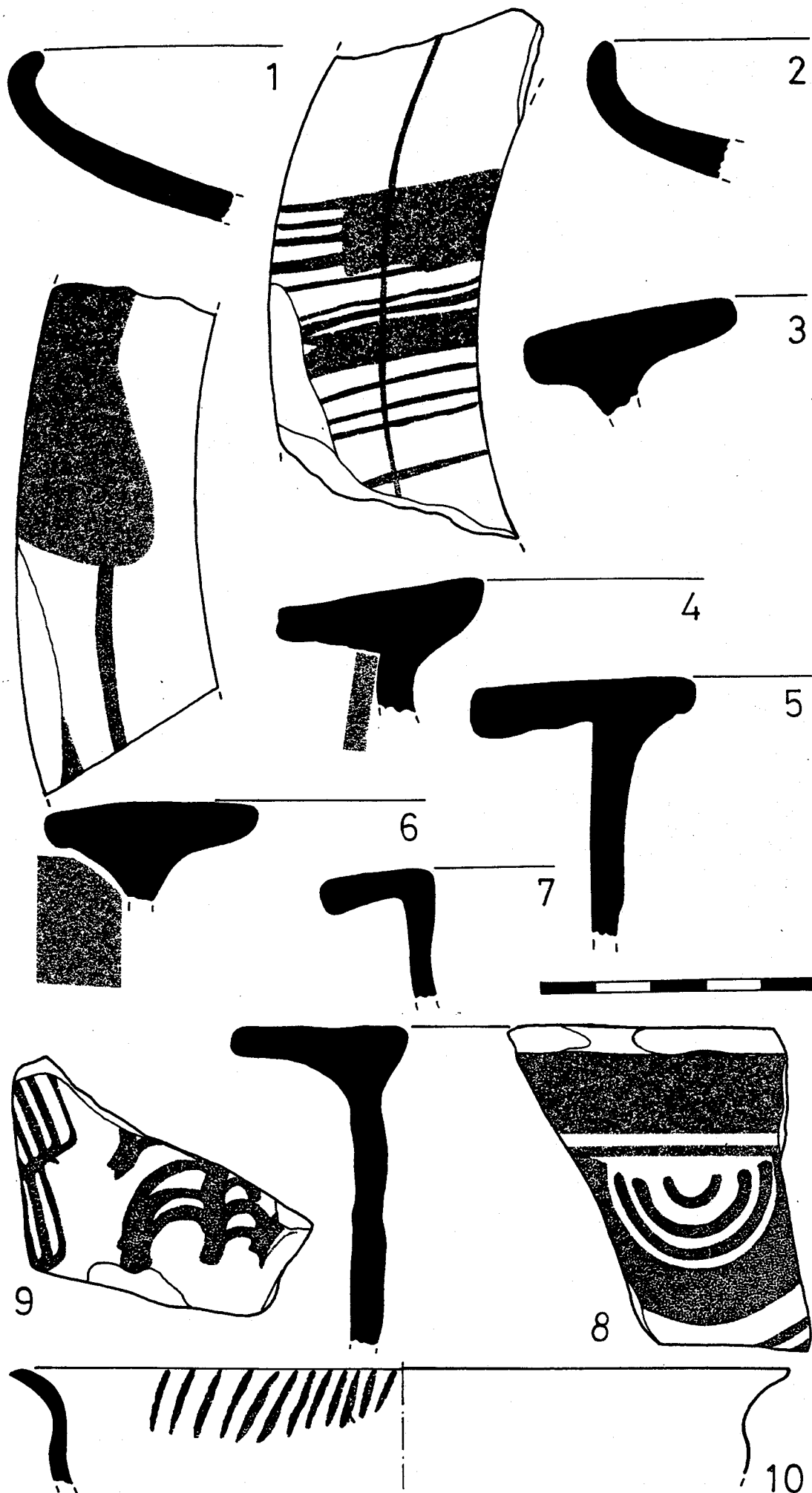

FIGURA 291

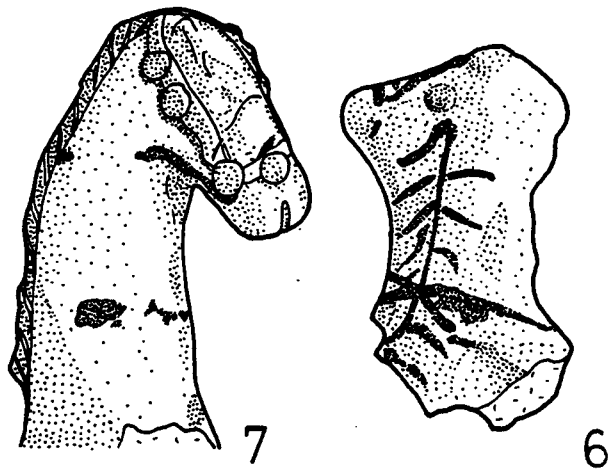
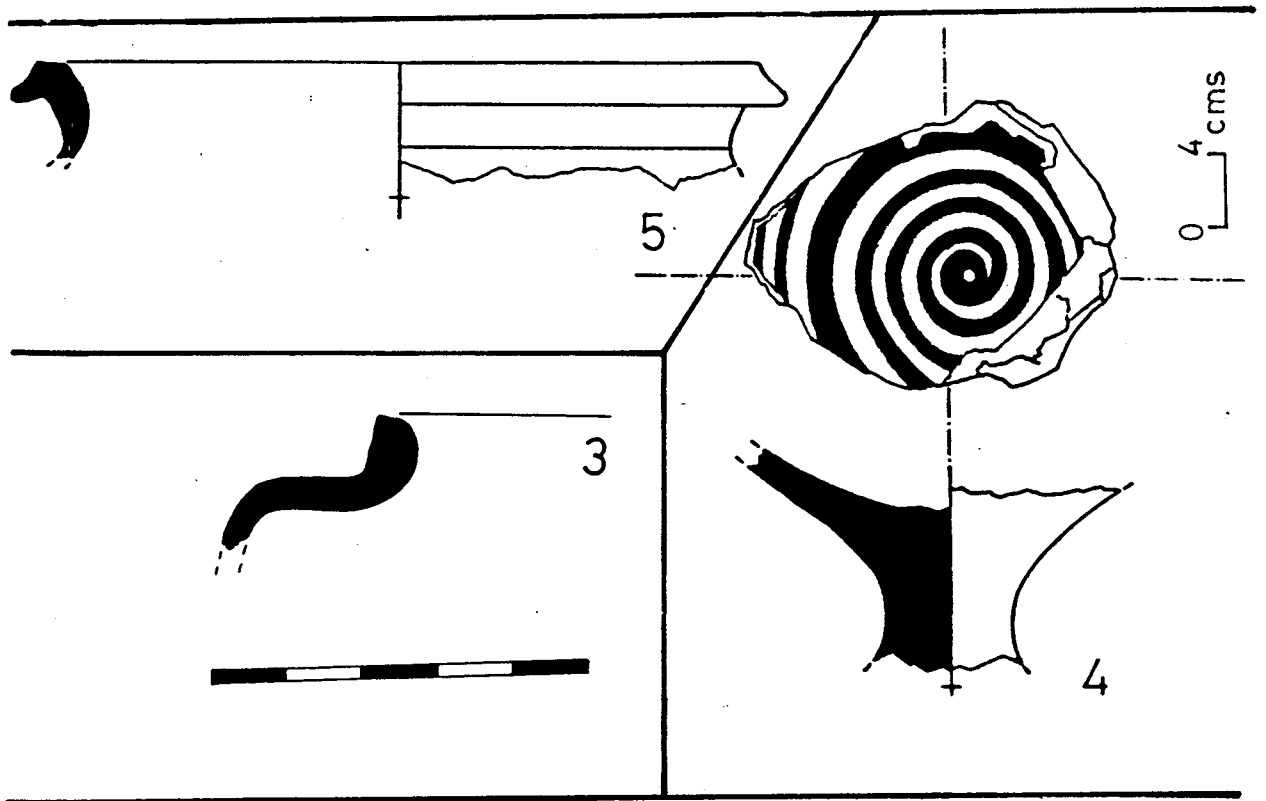
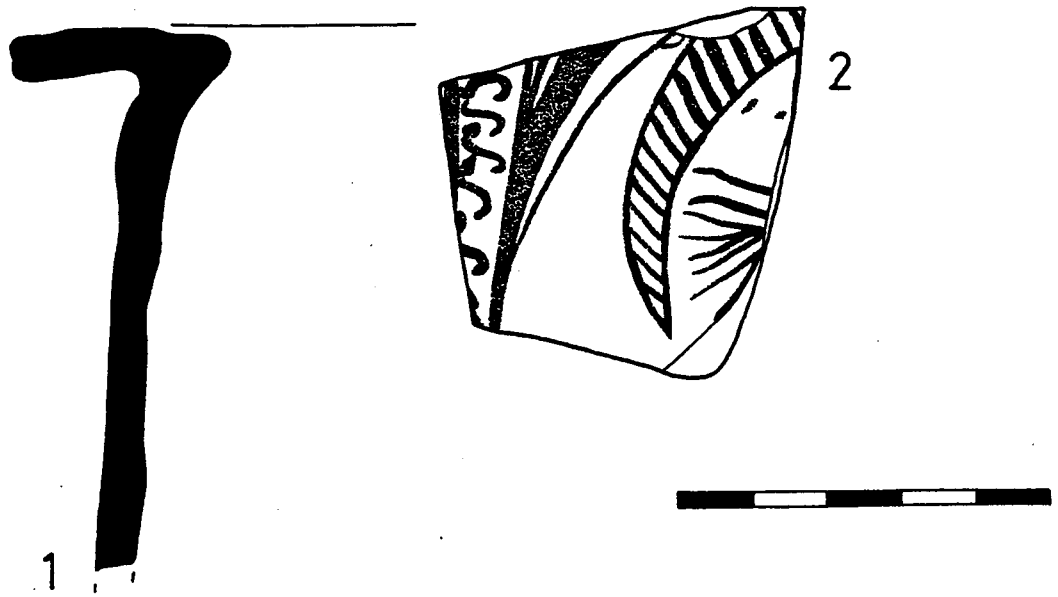

FIGURA 292

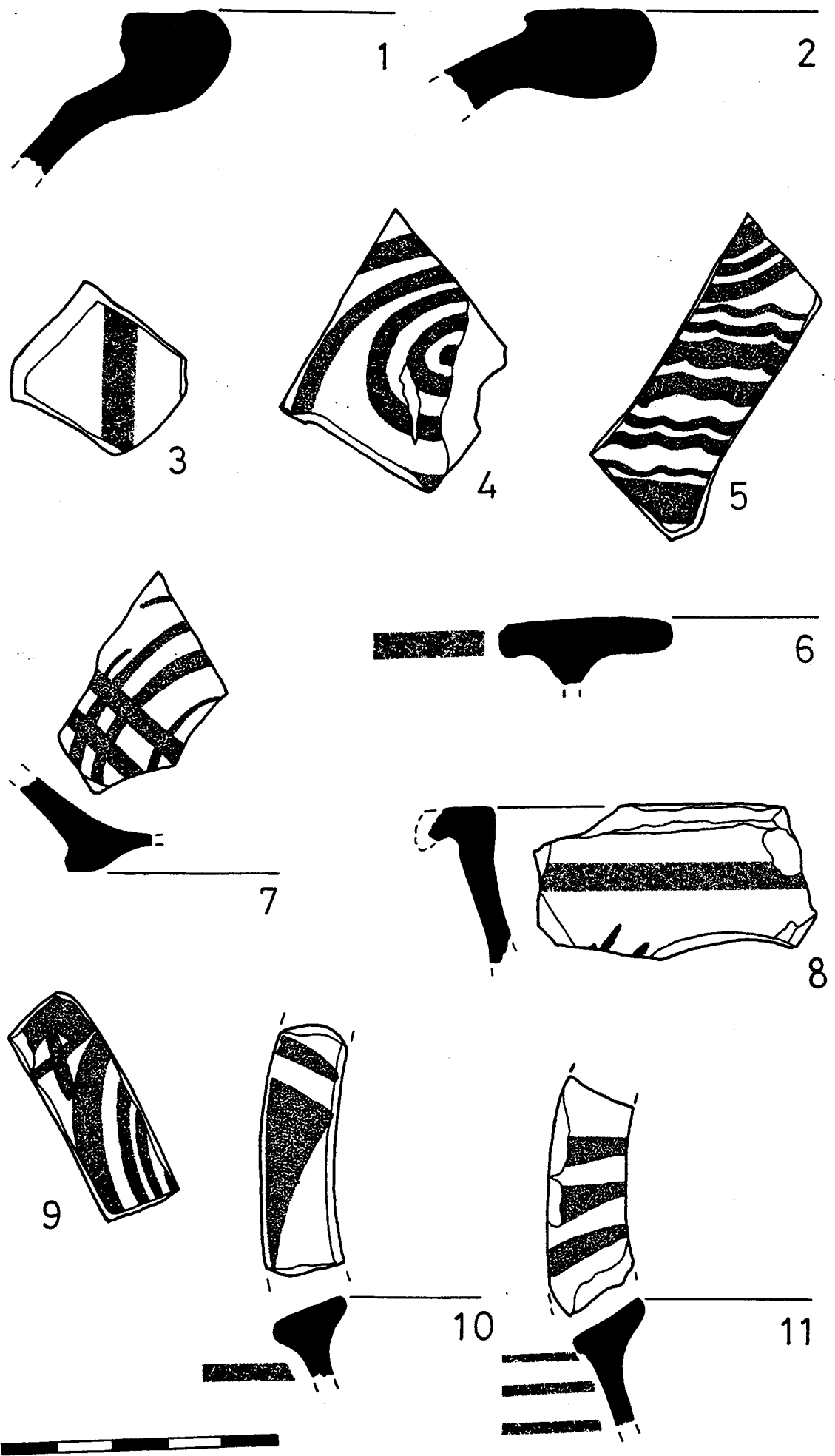

FIGURA 293

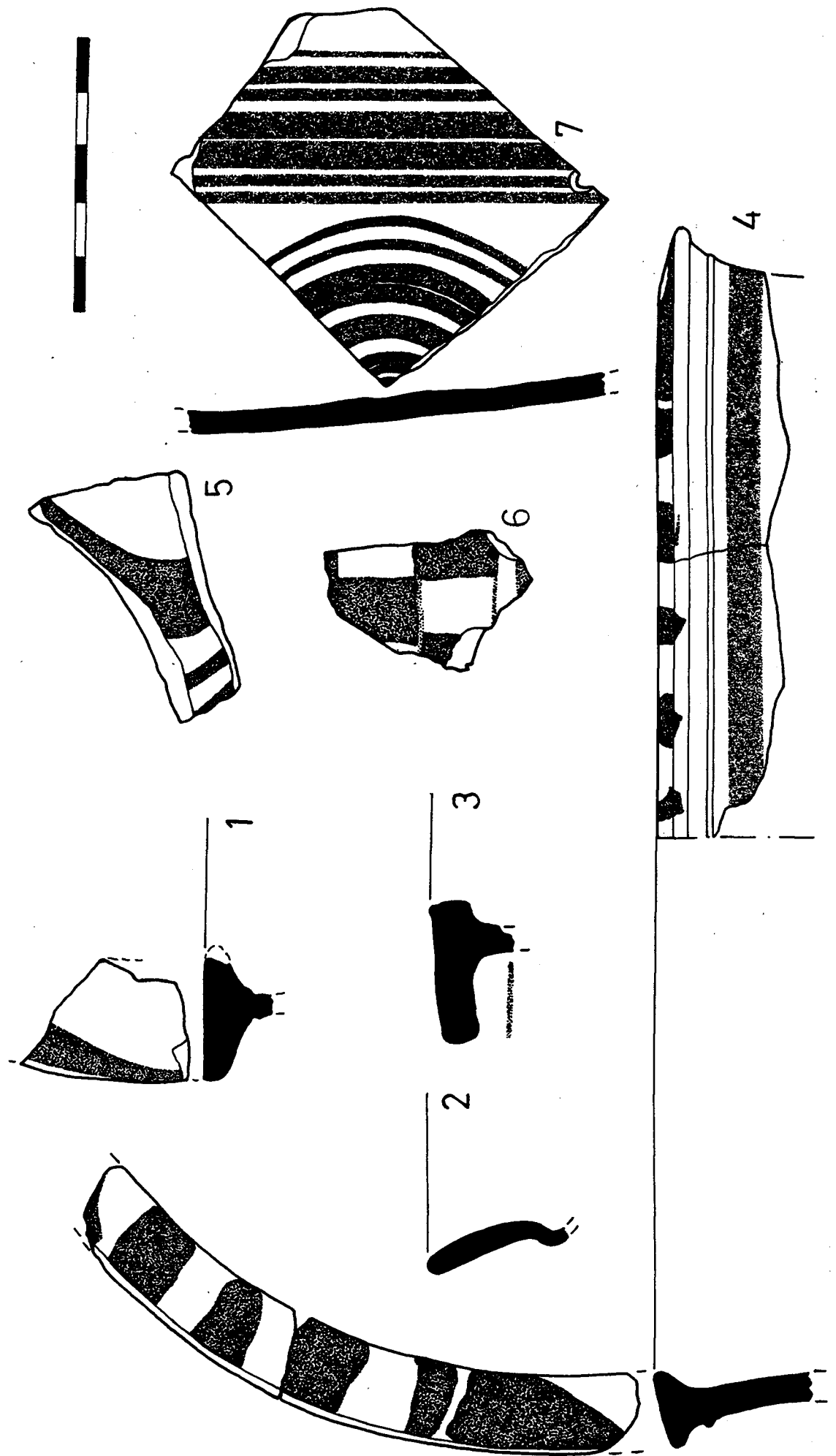

FIGURA 294

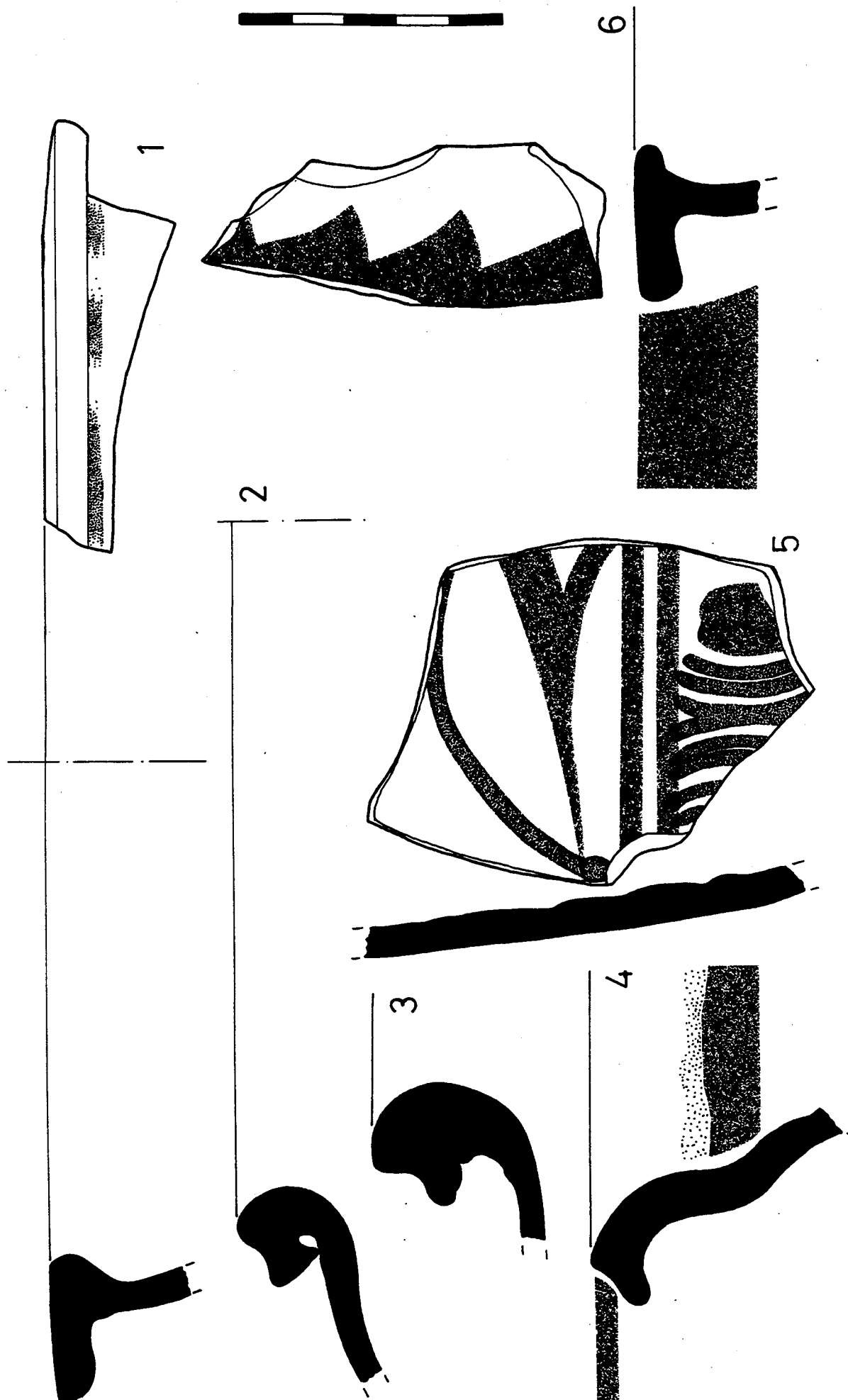

FIGURA 295

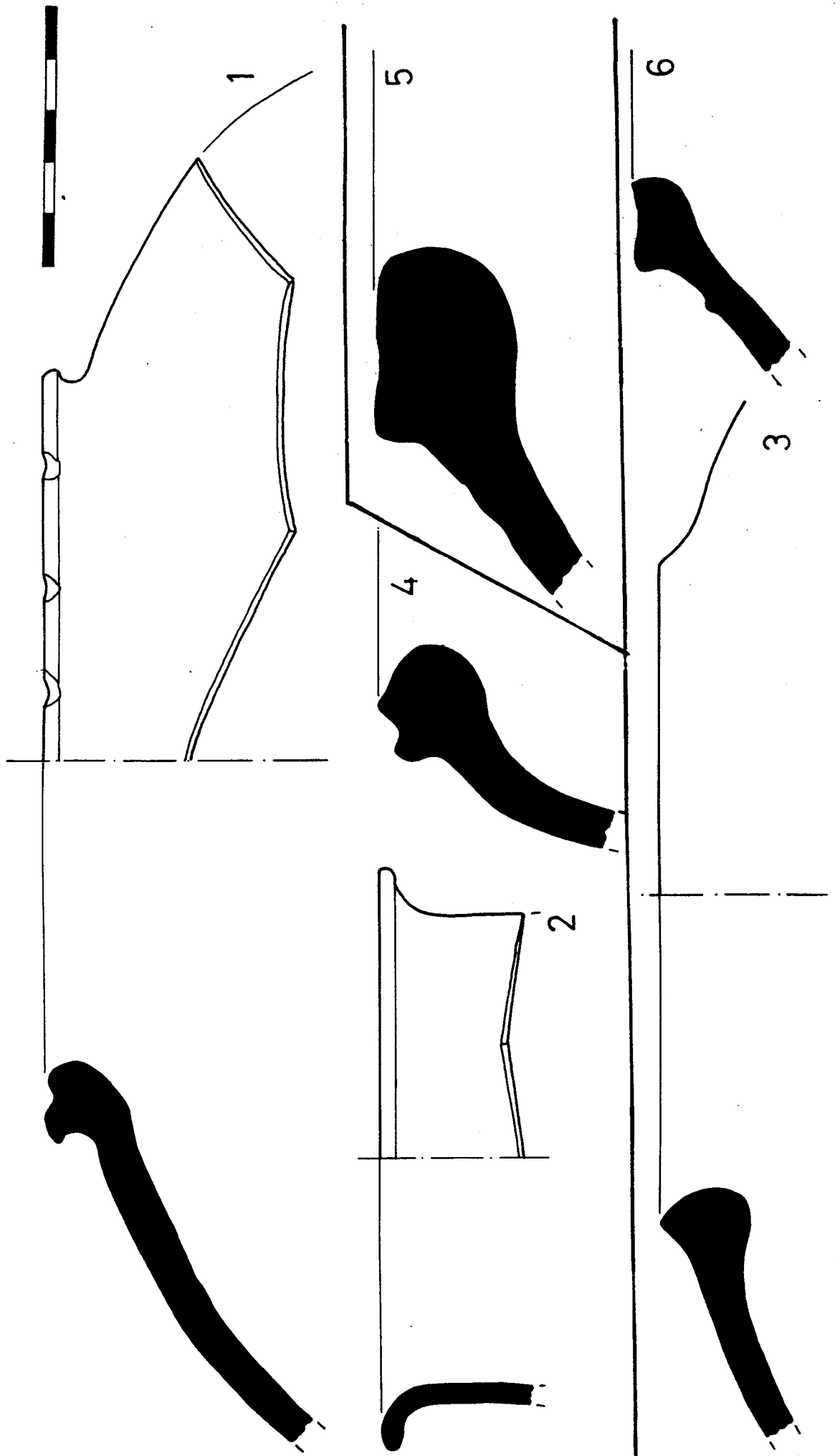

FIGURA 296

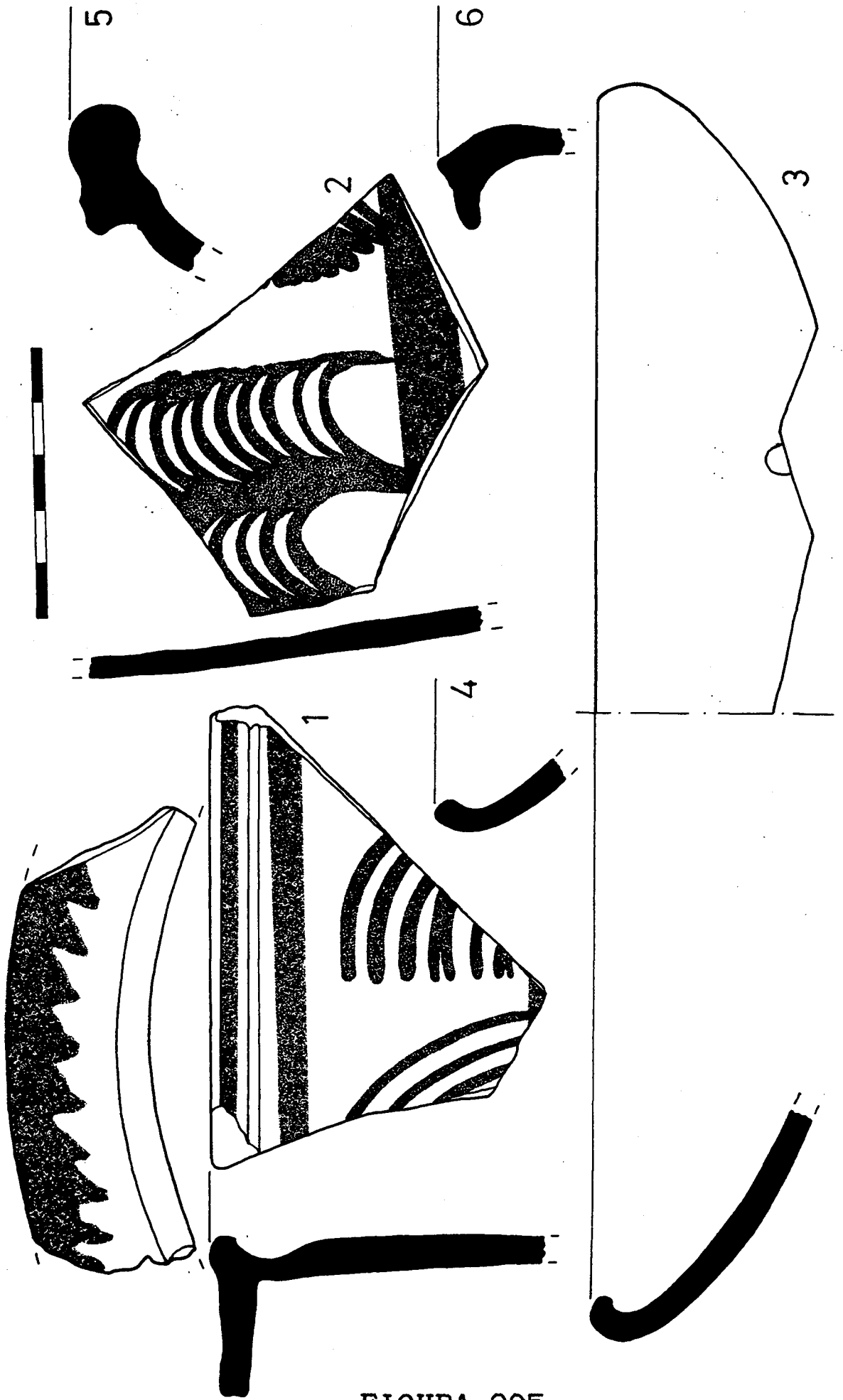

FIGURA 298

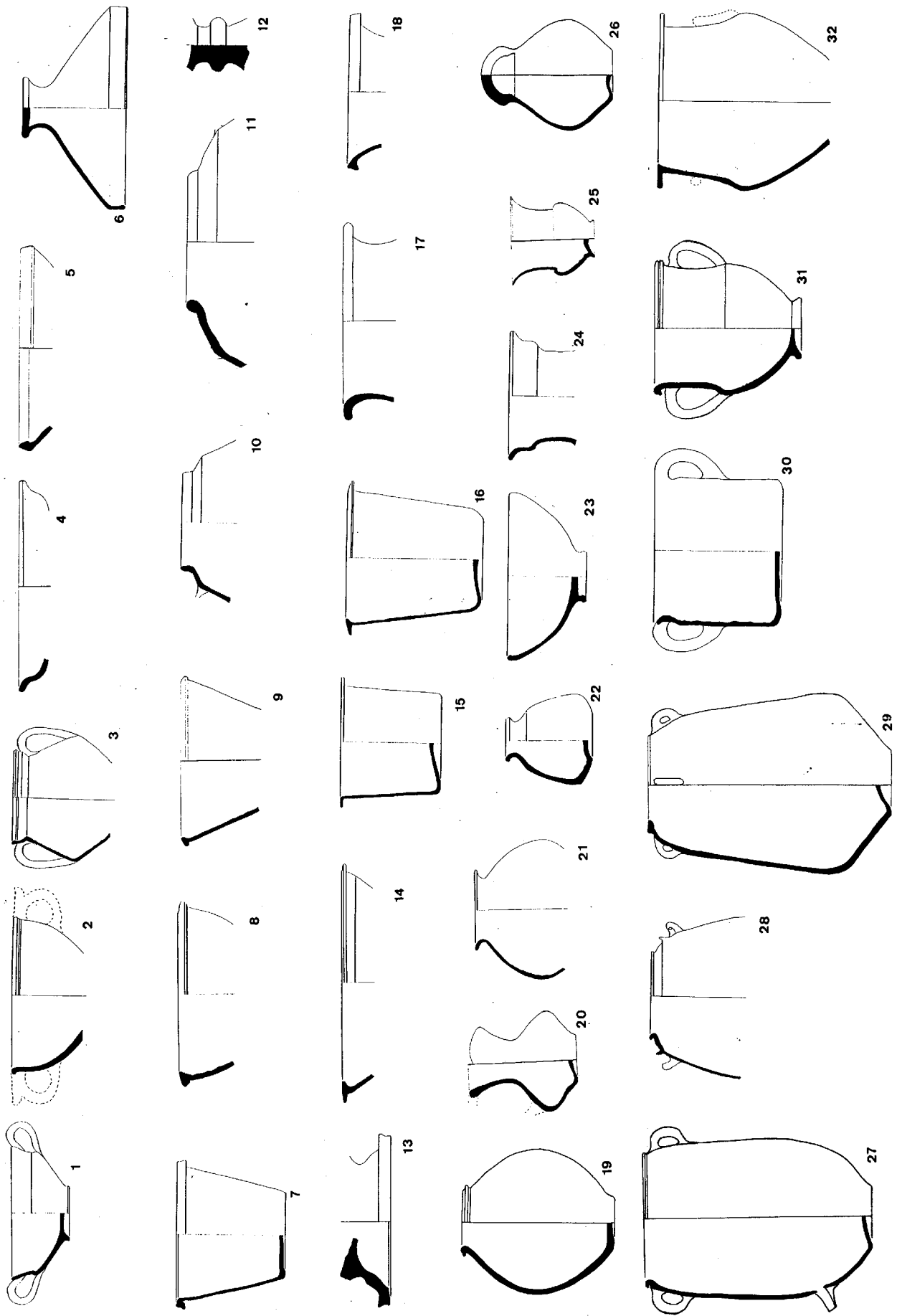

FIGURA 297

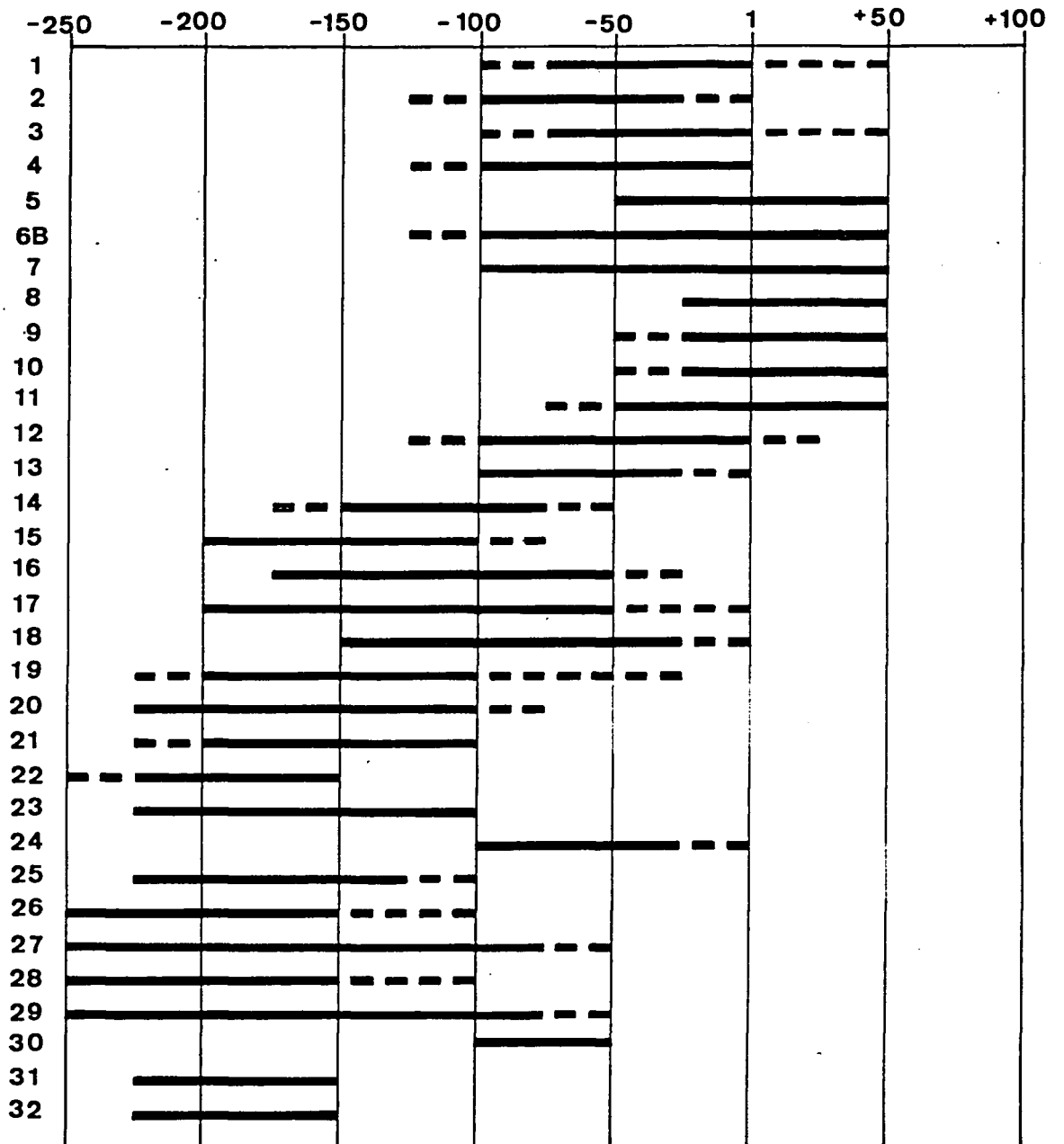

FIGURA 299

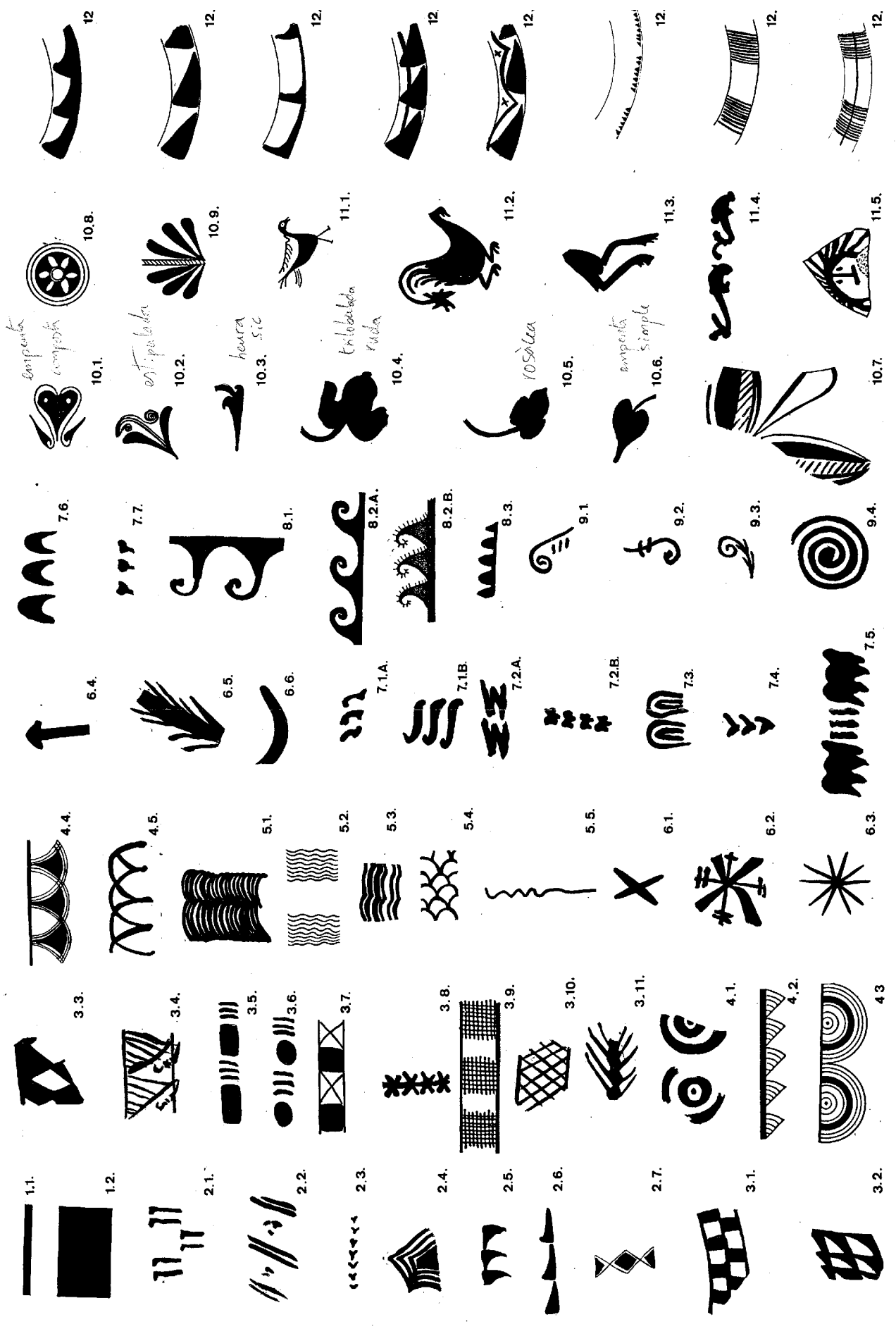

FIGURA 300

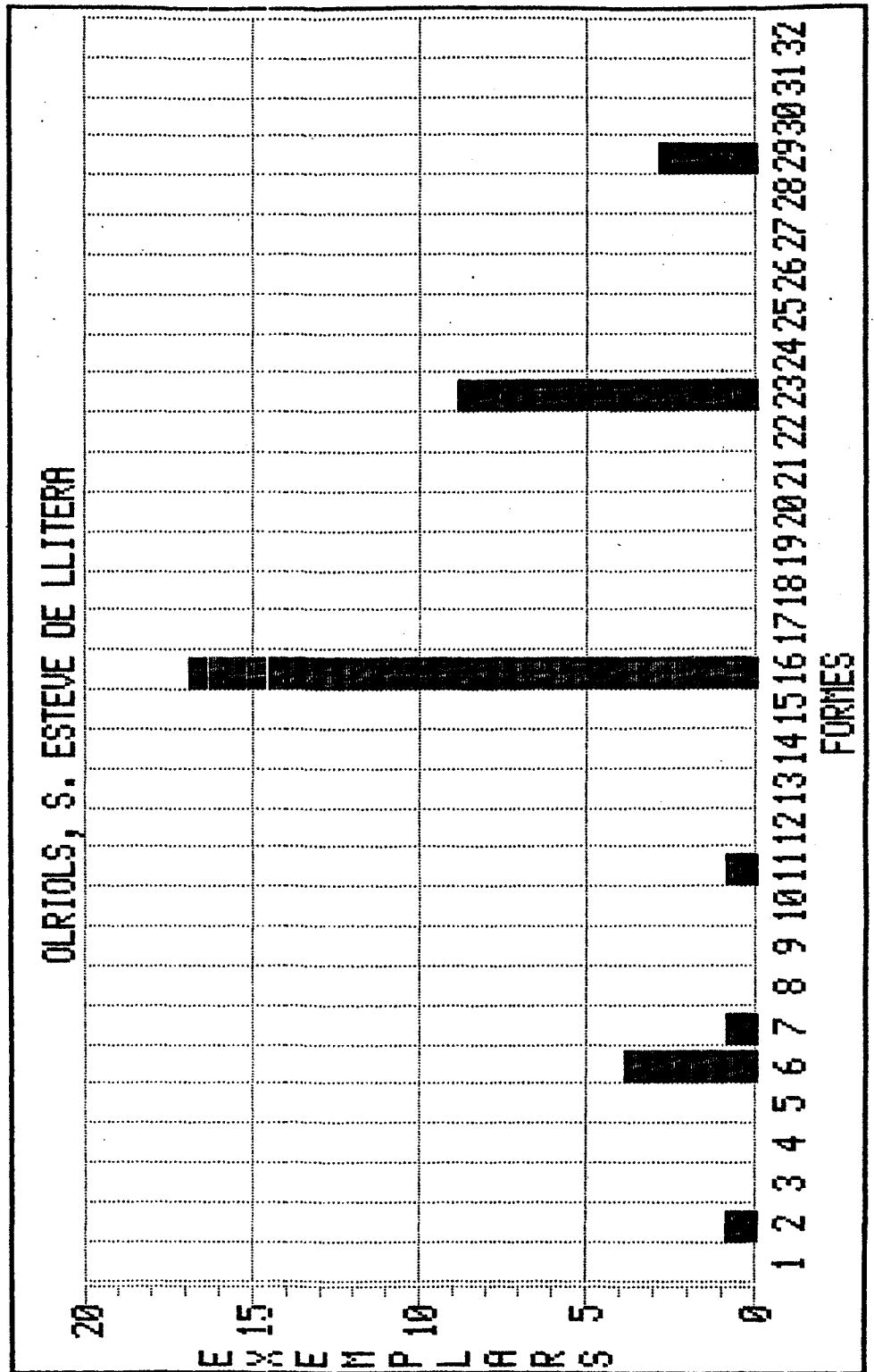

FIGURA 301

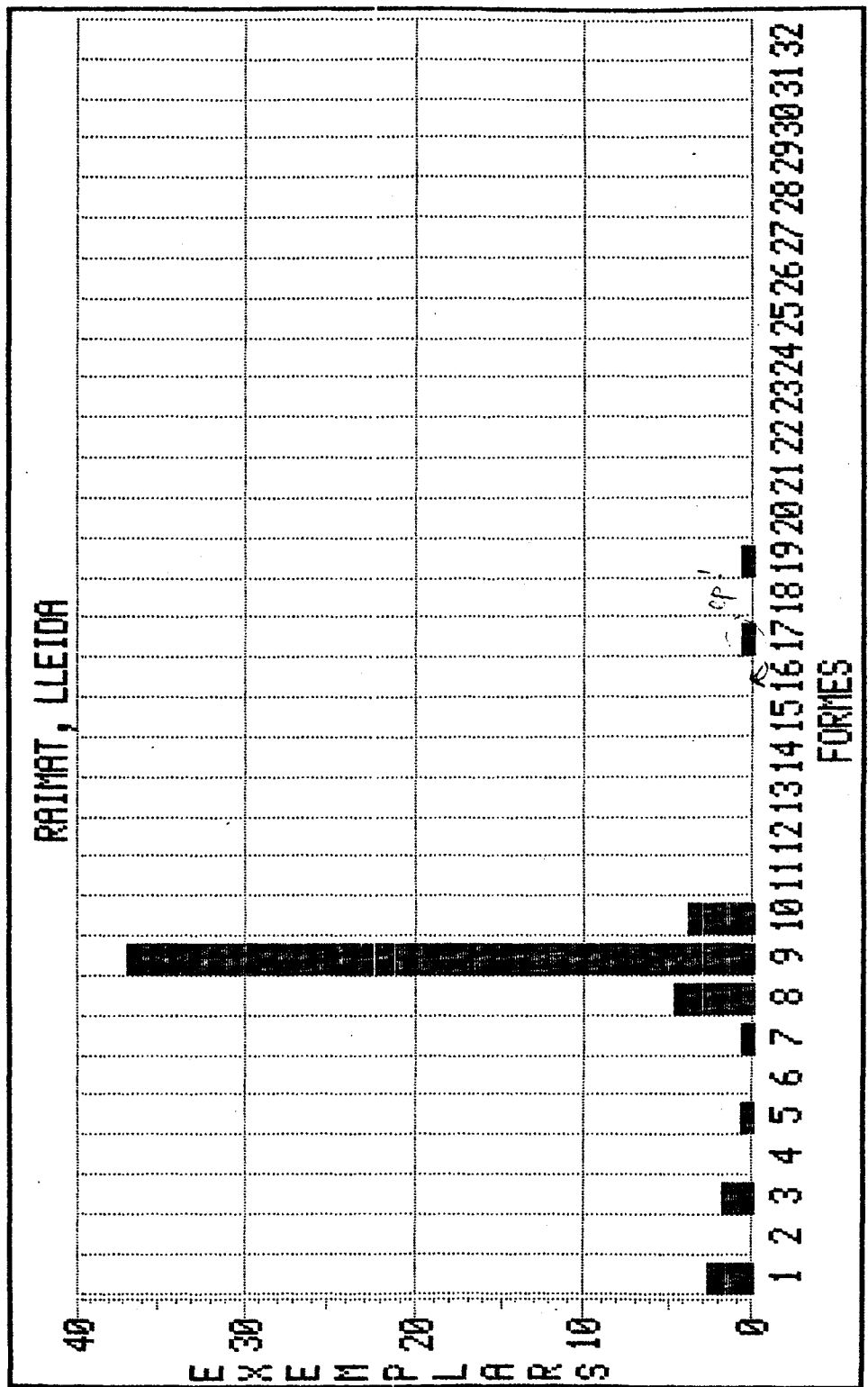

FIGURA 302

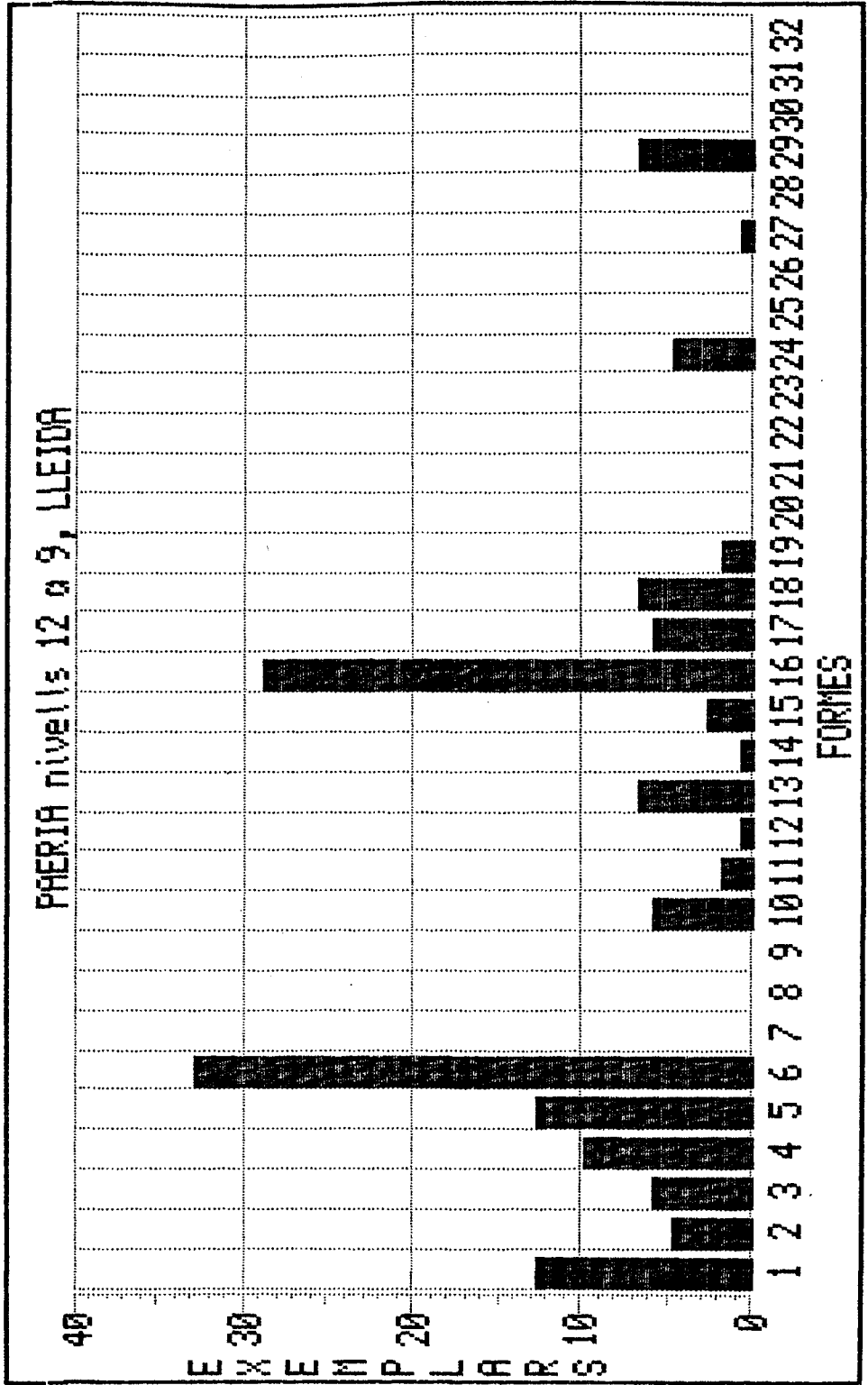

FIGURA 303

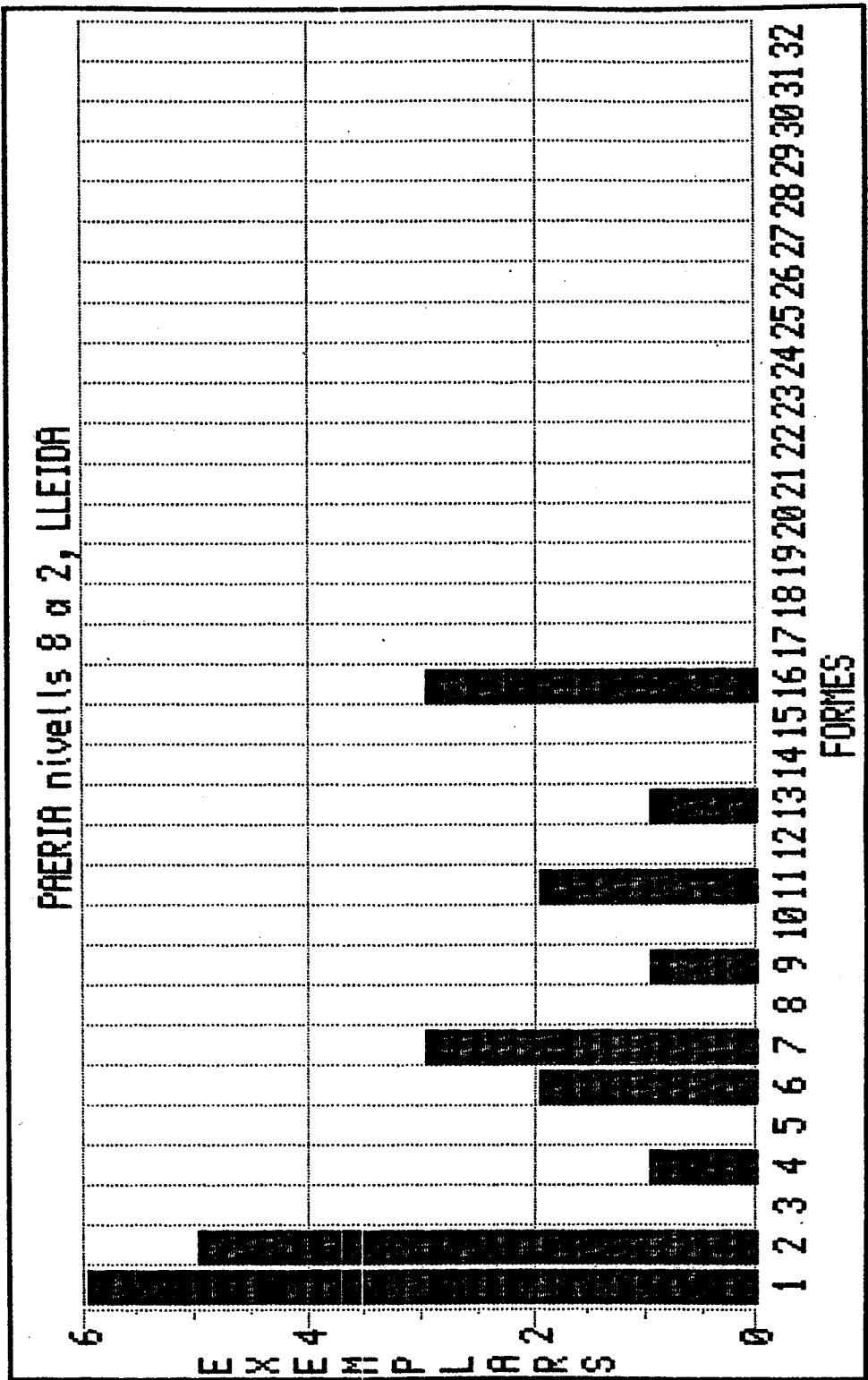

FIGURA 304

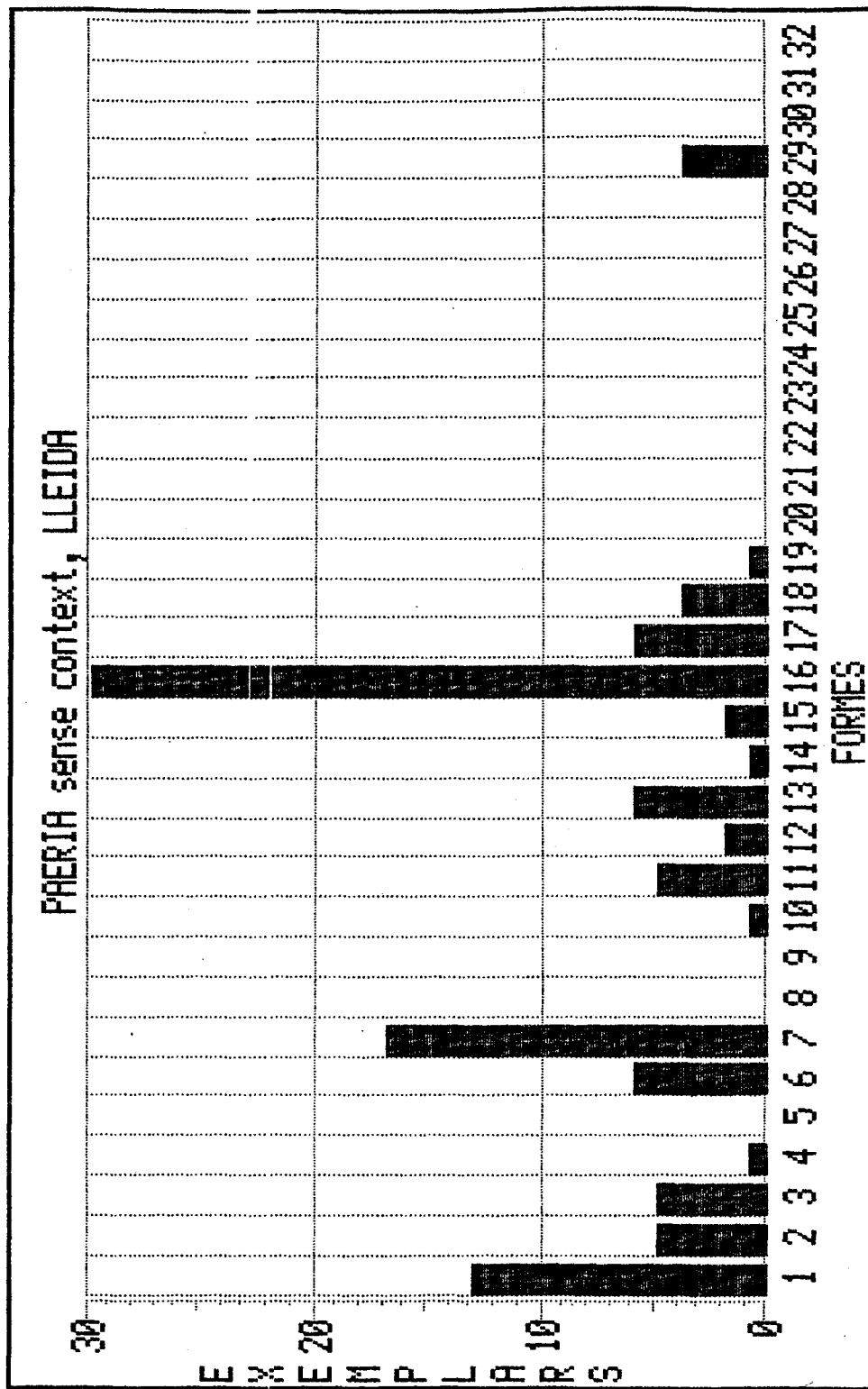

FIGURA 305

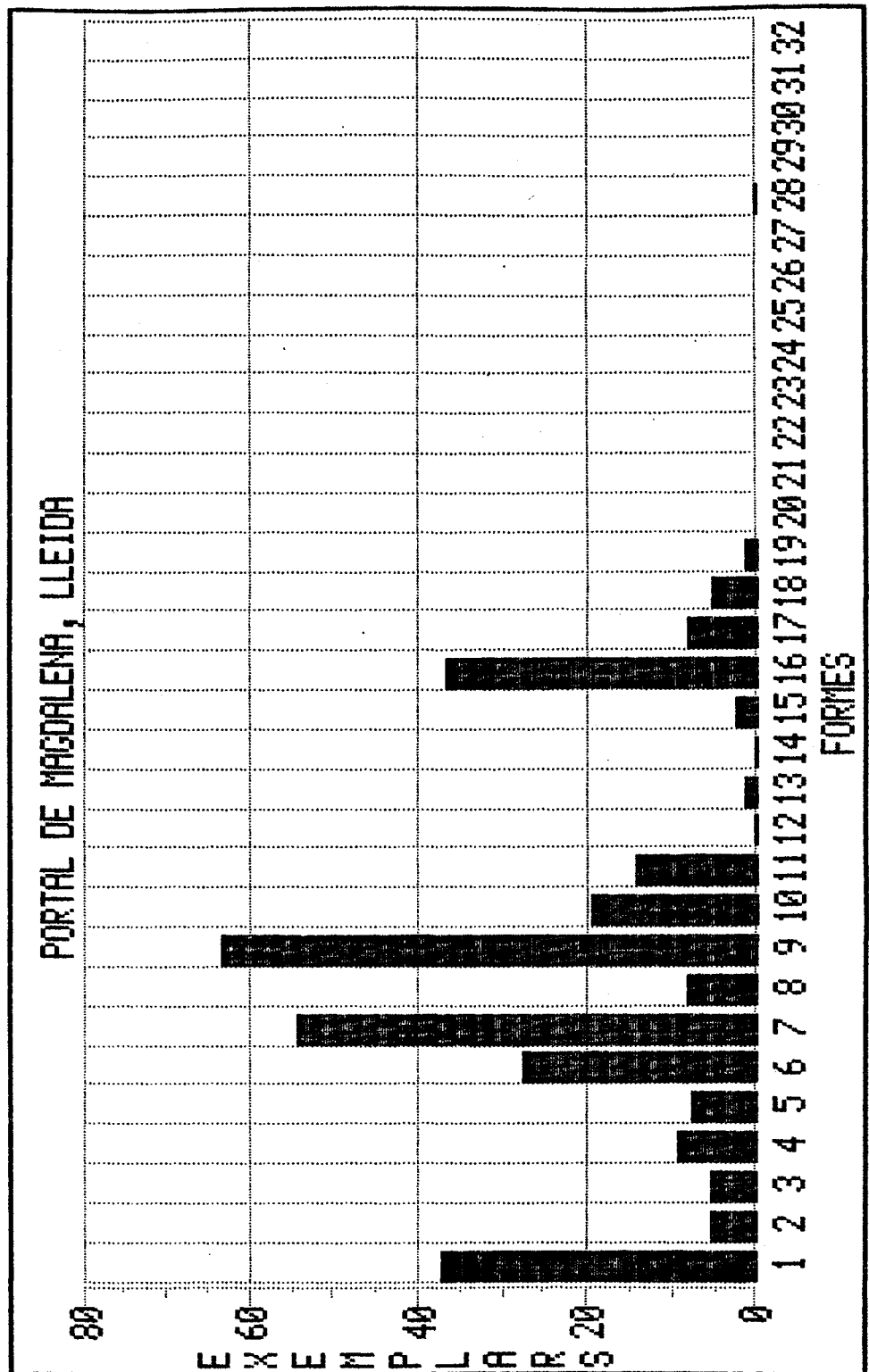

- s. II-a.C.
- s. II-l.a.C.
- ▼ s. I.a.C.
- ⊙ s. II-a.C.-Id.C.
- s. I.a.C.-Id.C.
- s. Id.C.
- ↑ noticia indet.

FIGURA 306

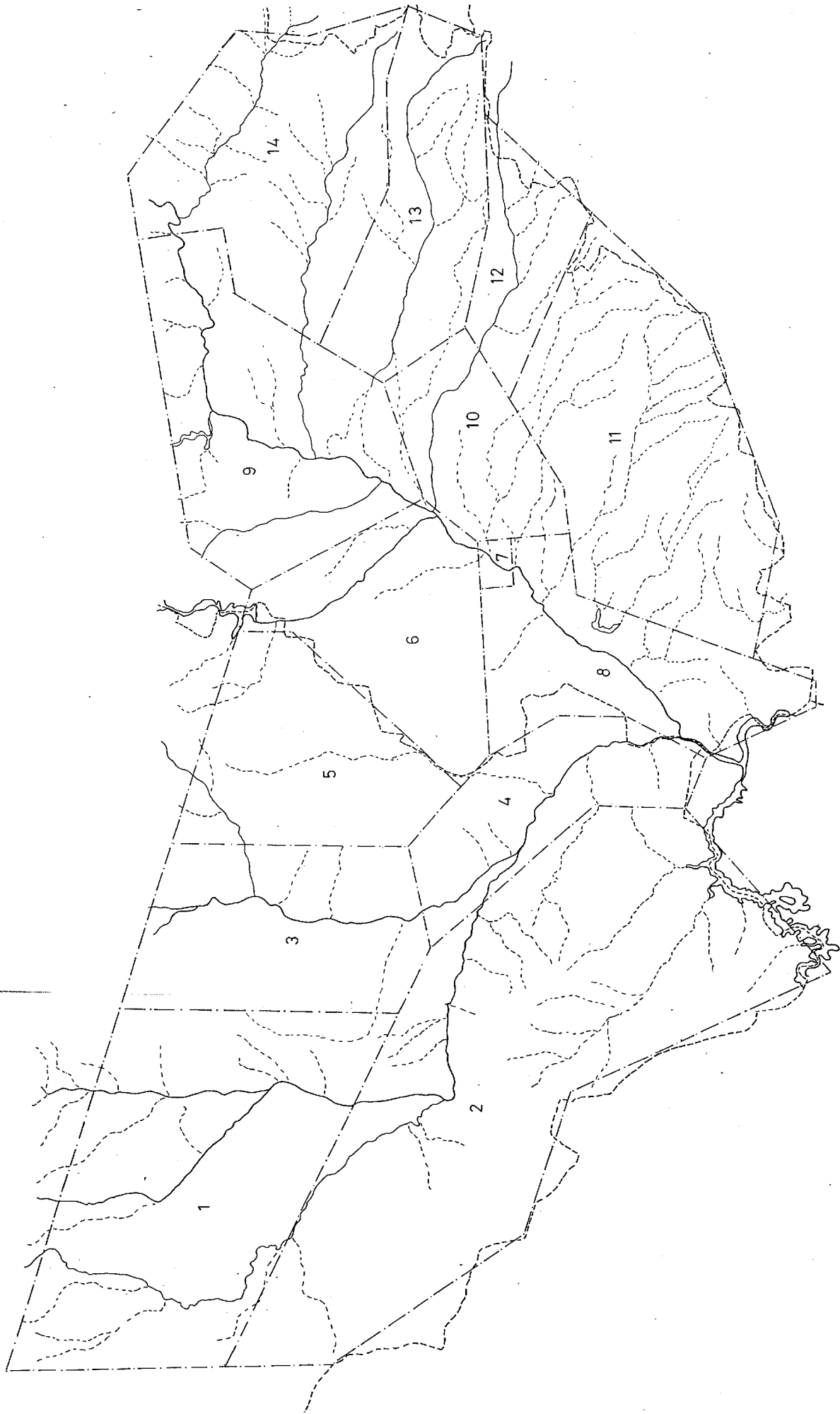
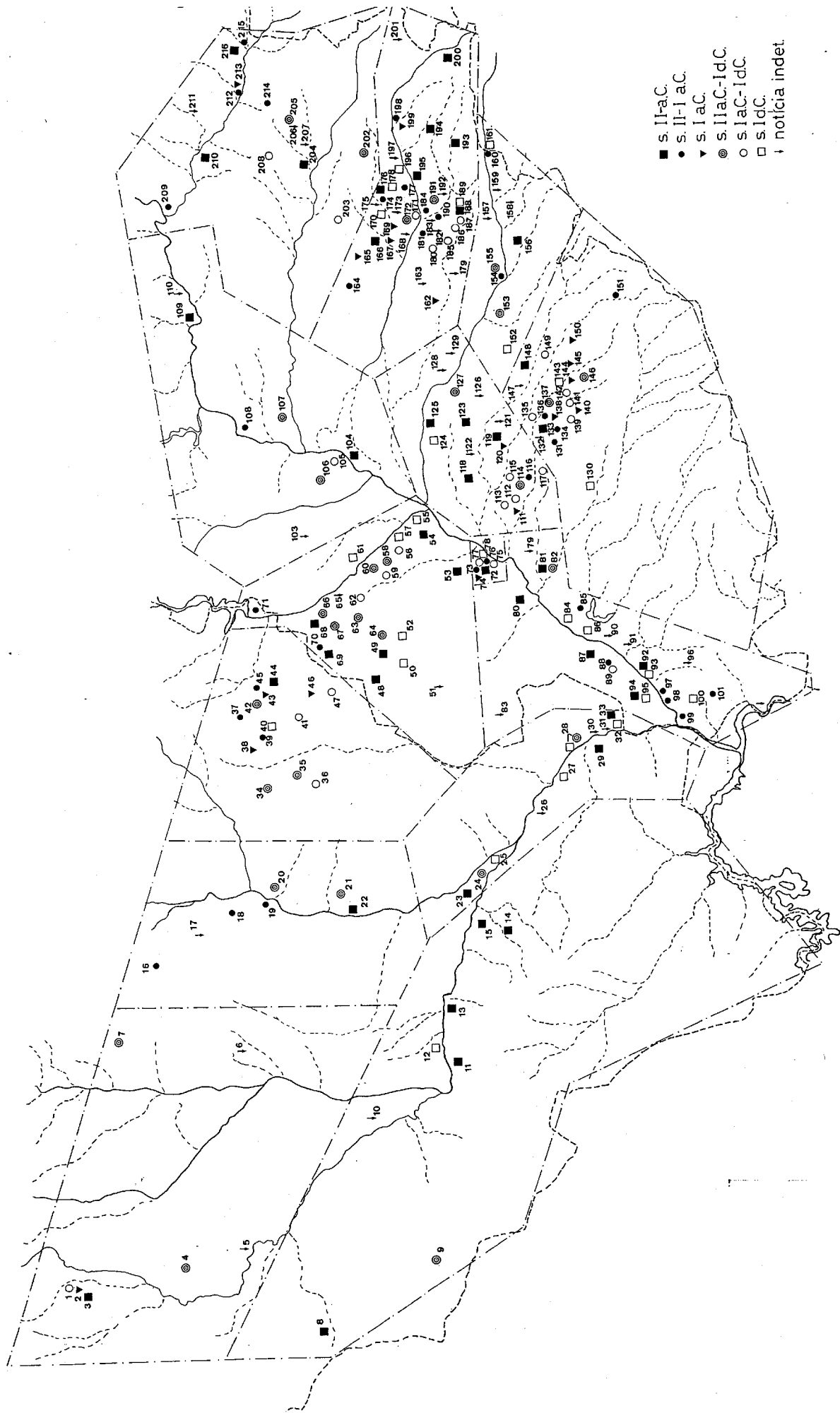
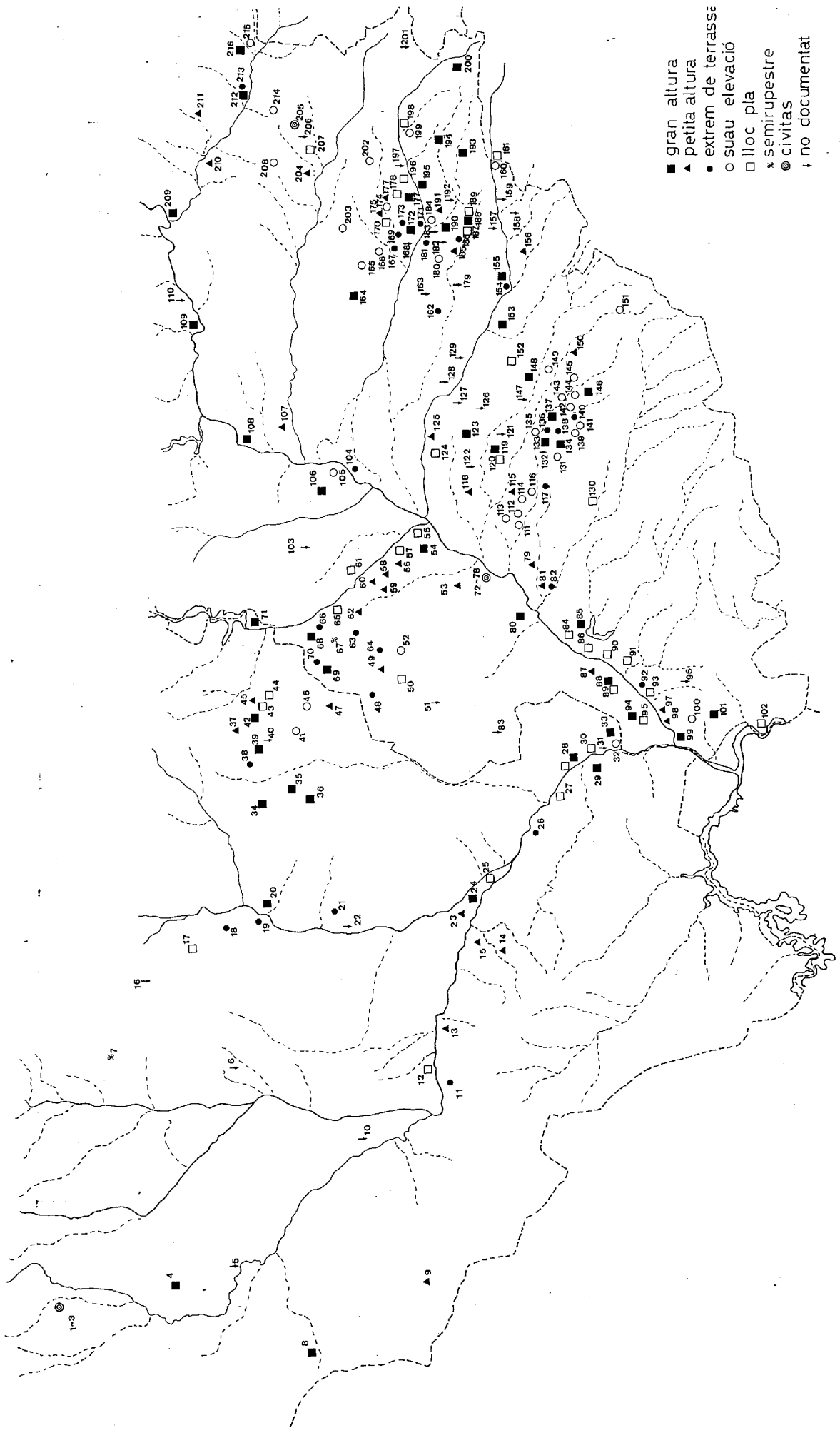

- gran altura
- ▲ petita altura
- extrem de terrassó
- osuau elevació
- lloc pla
- * semirurpestre
- ⊙ civitas
- † no documentat

FIGURA 307

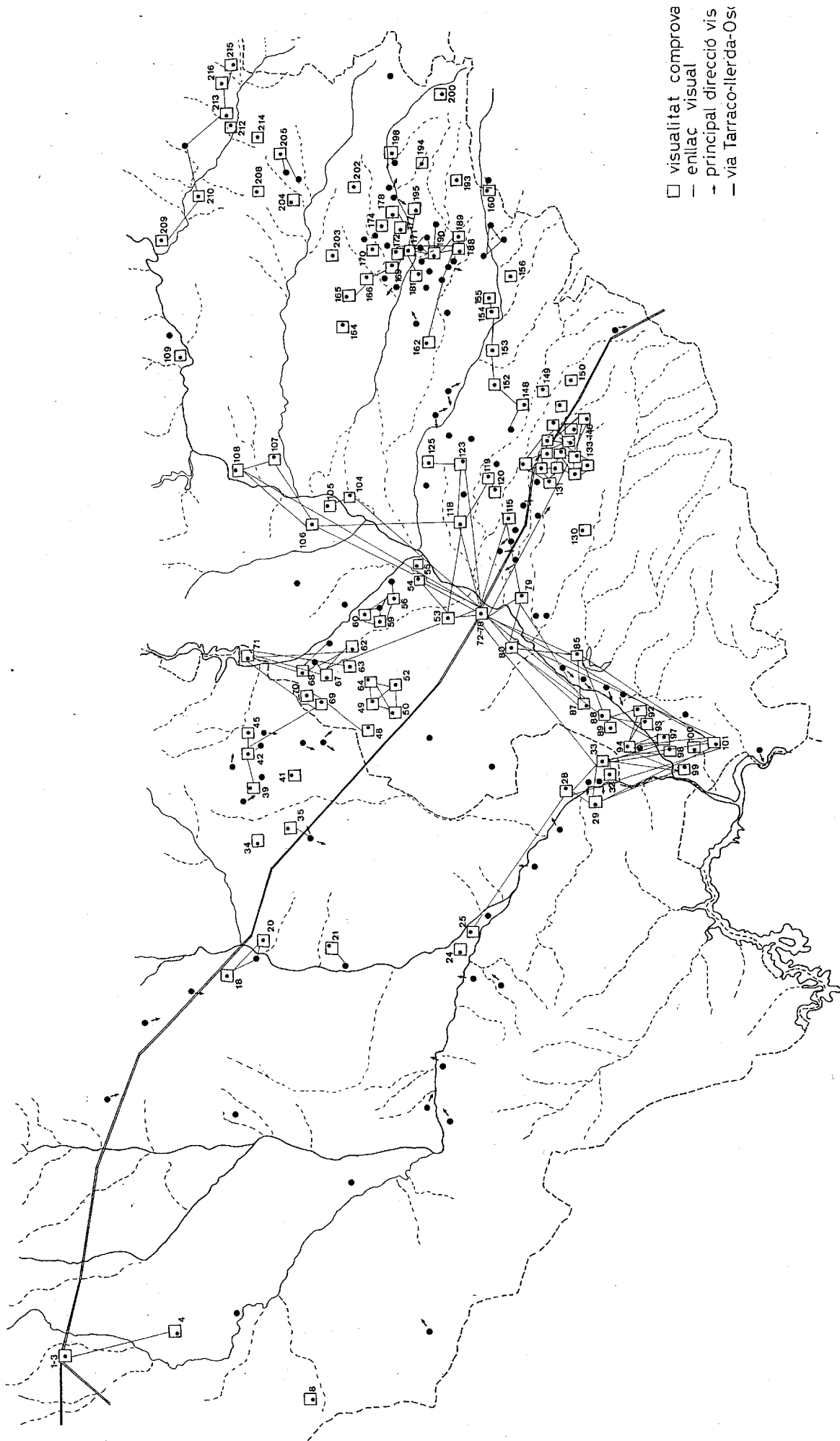

- visualitat comprova
- - - enllac visual
- · - principal direcció vis
- via Tarraco-Ilerda-Os

FIGURA 308



FIGURA 309



FIGURA 310

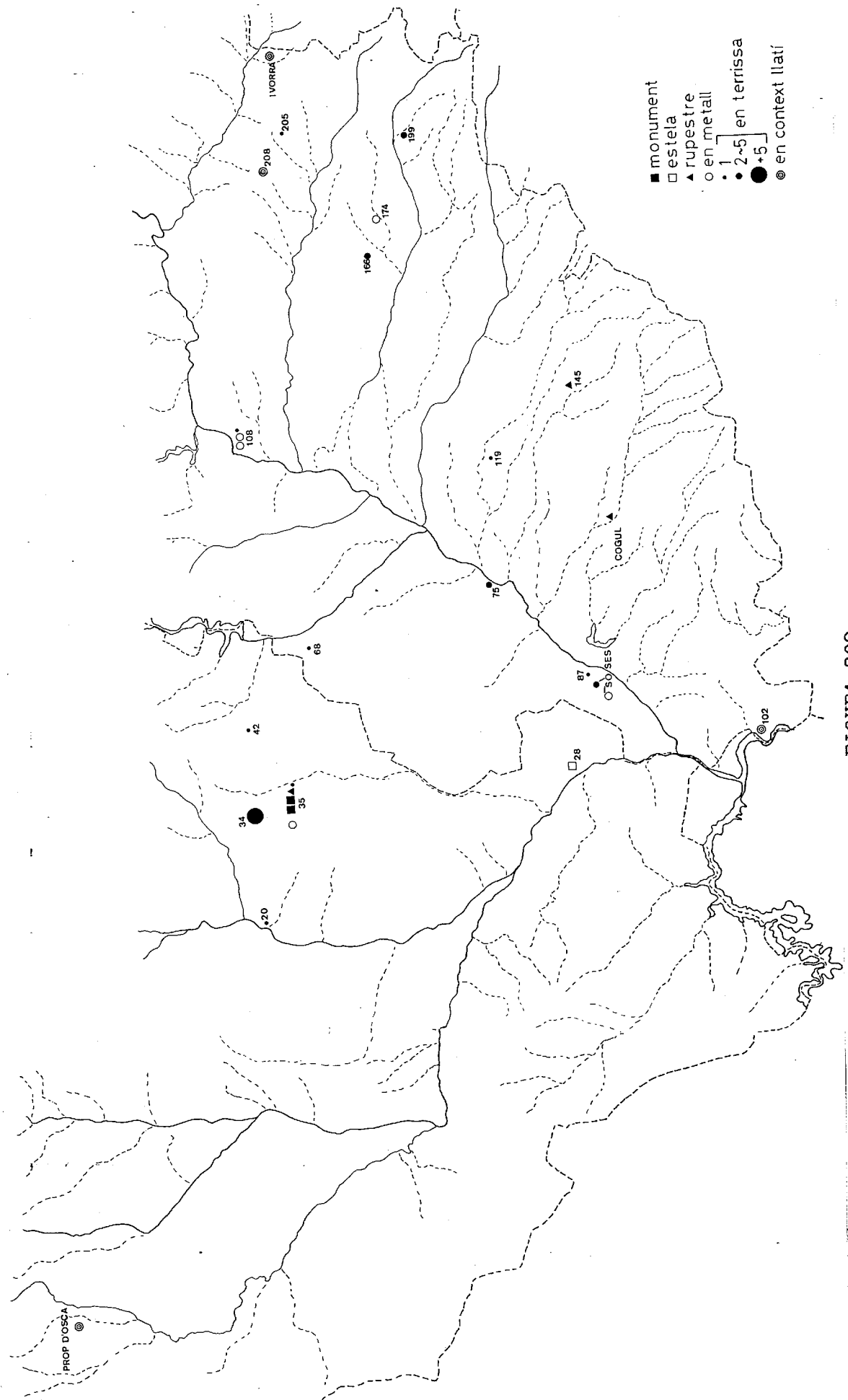

FIGURA 312

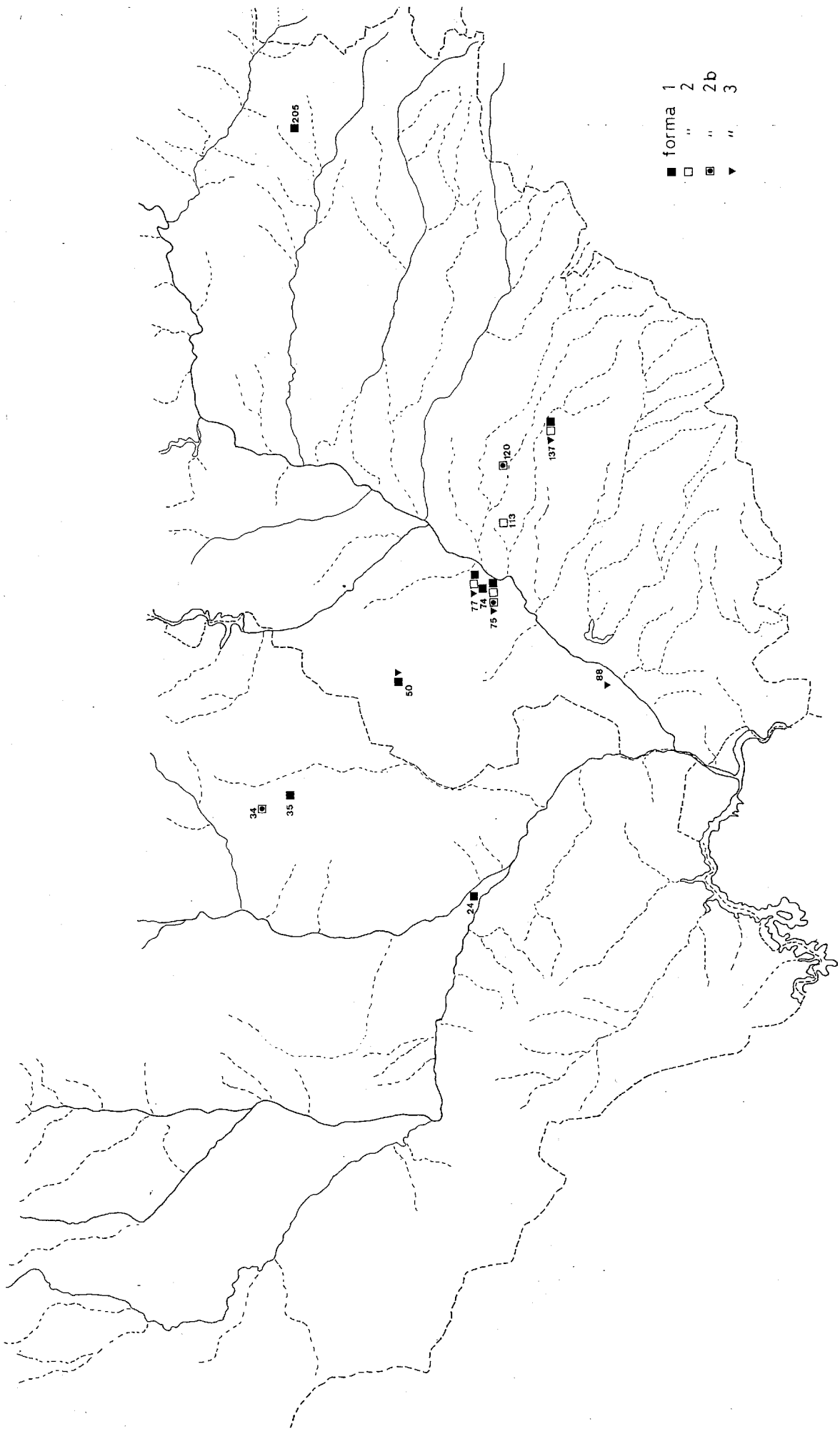

FIGURA 313

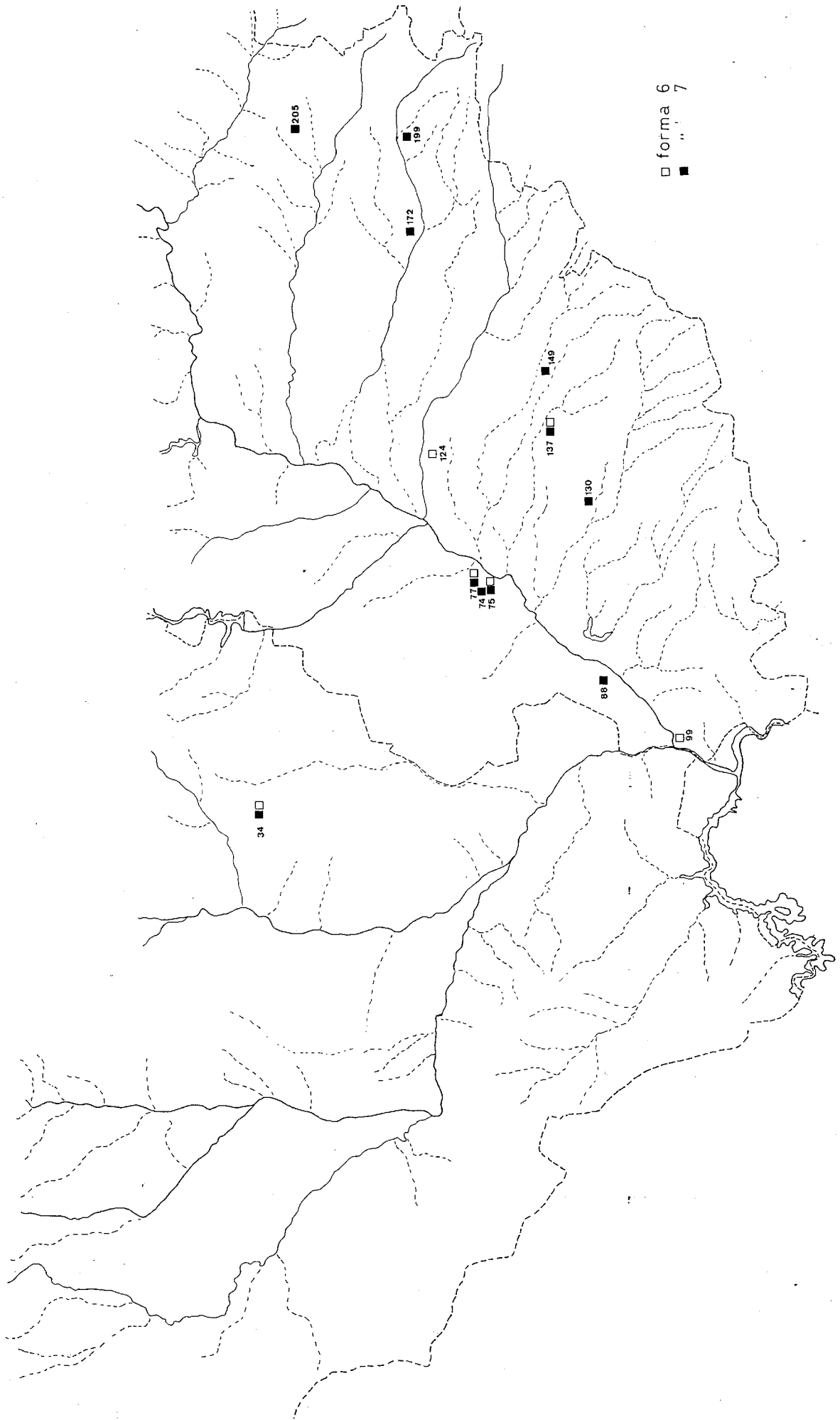

FIGURA 314

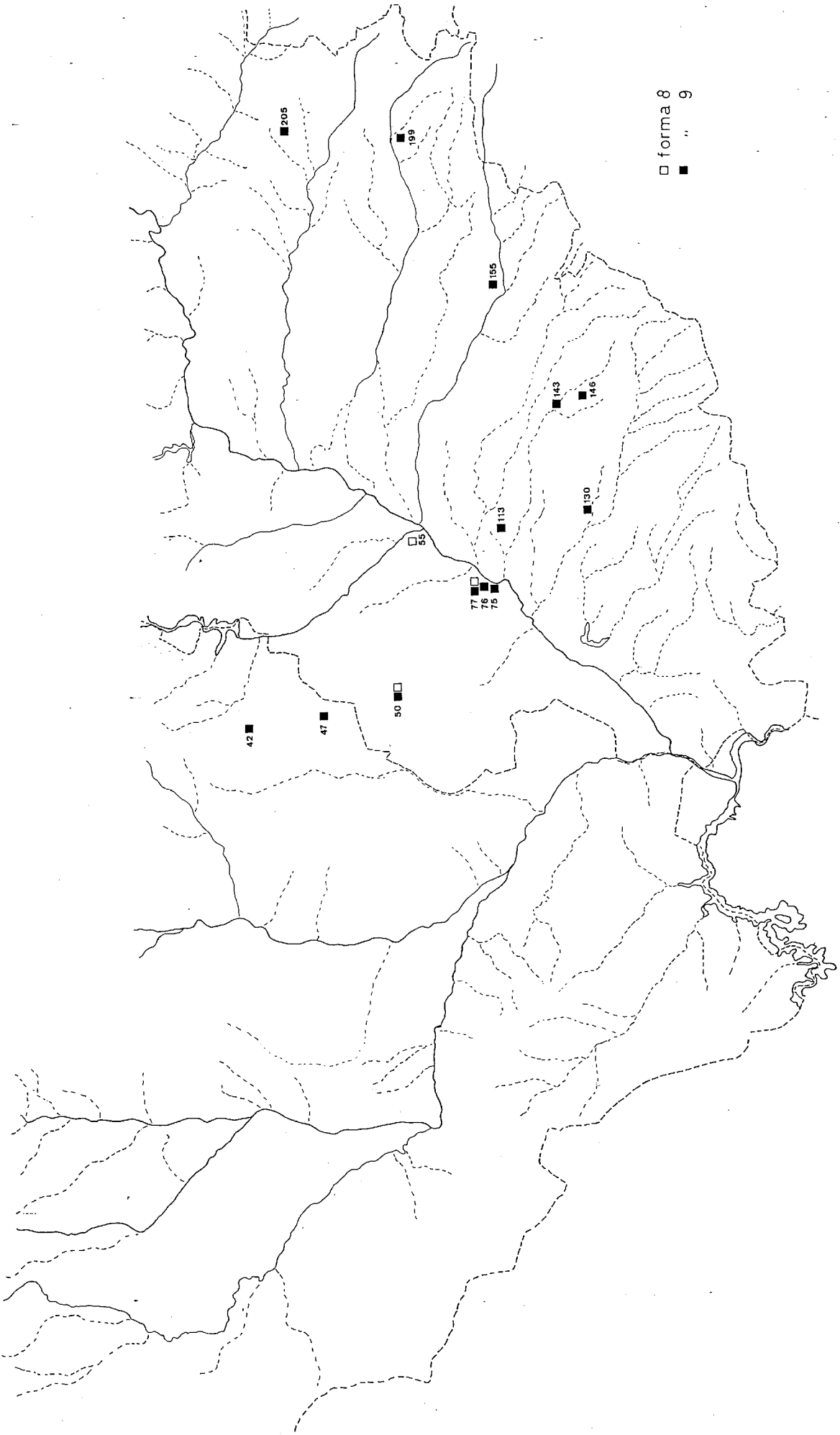

⊗ forma 12
 ■ " 13
 ▼ " 14

FIGURA 315

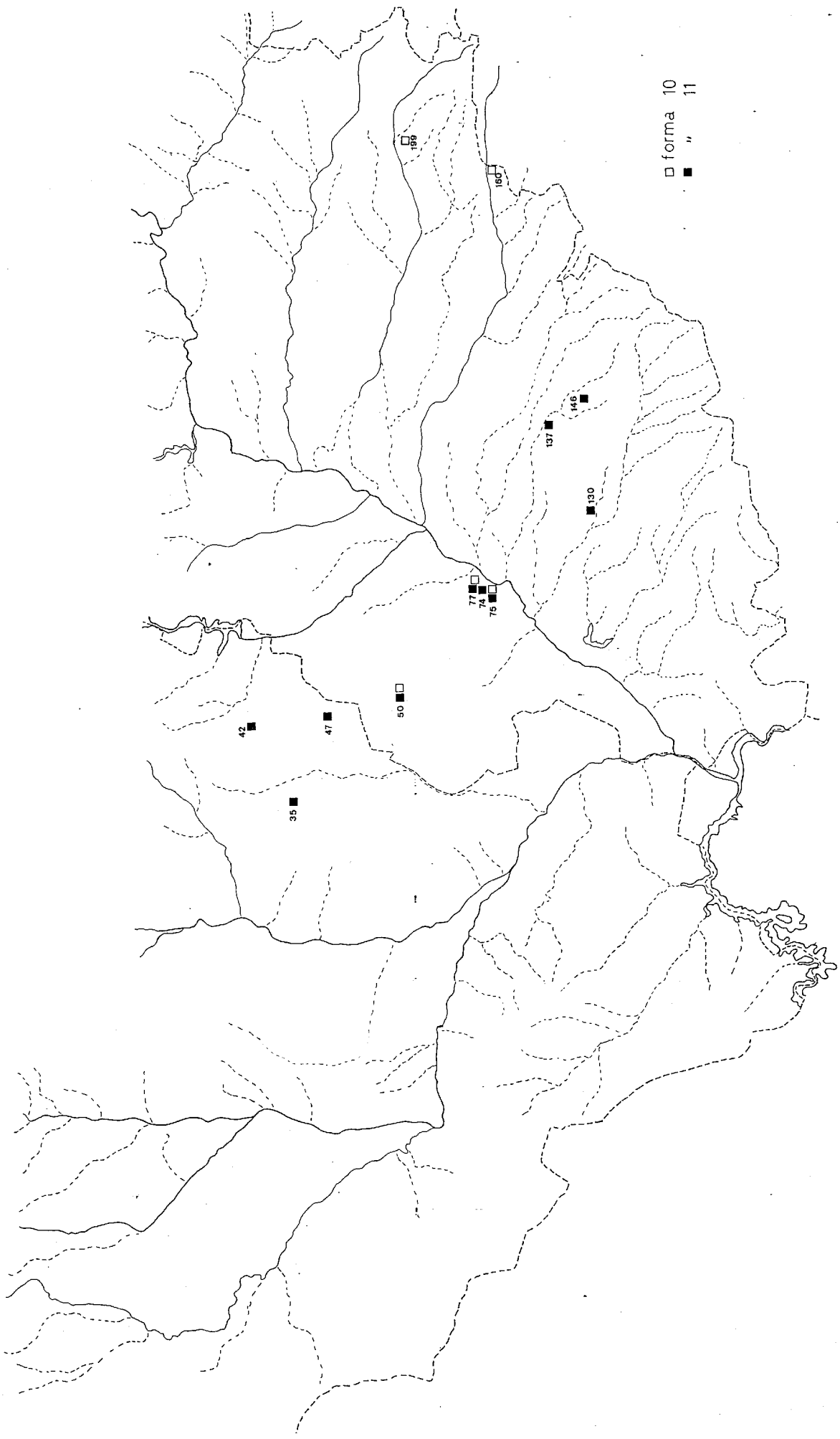
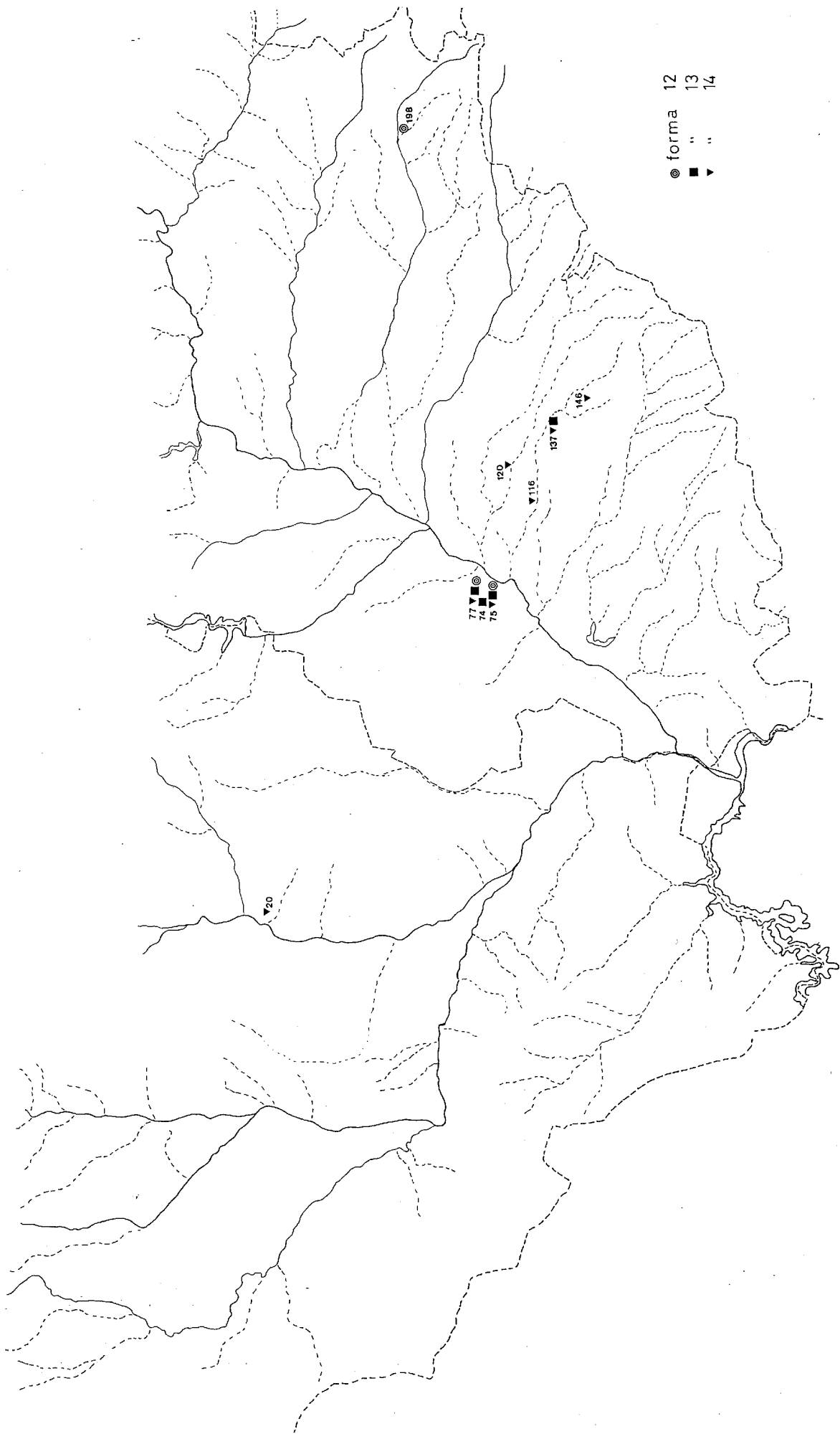

FIGURA 316



FIGURA 316

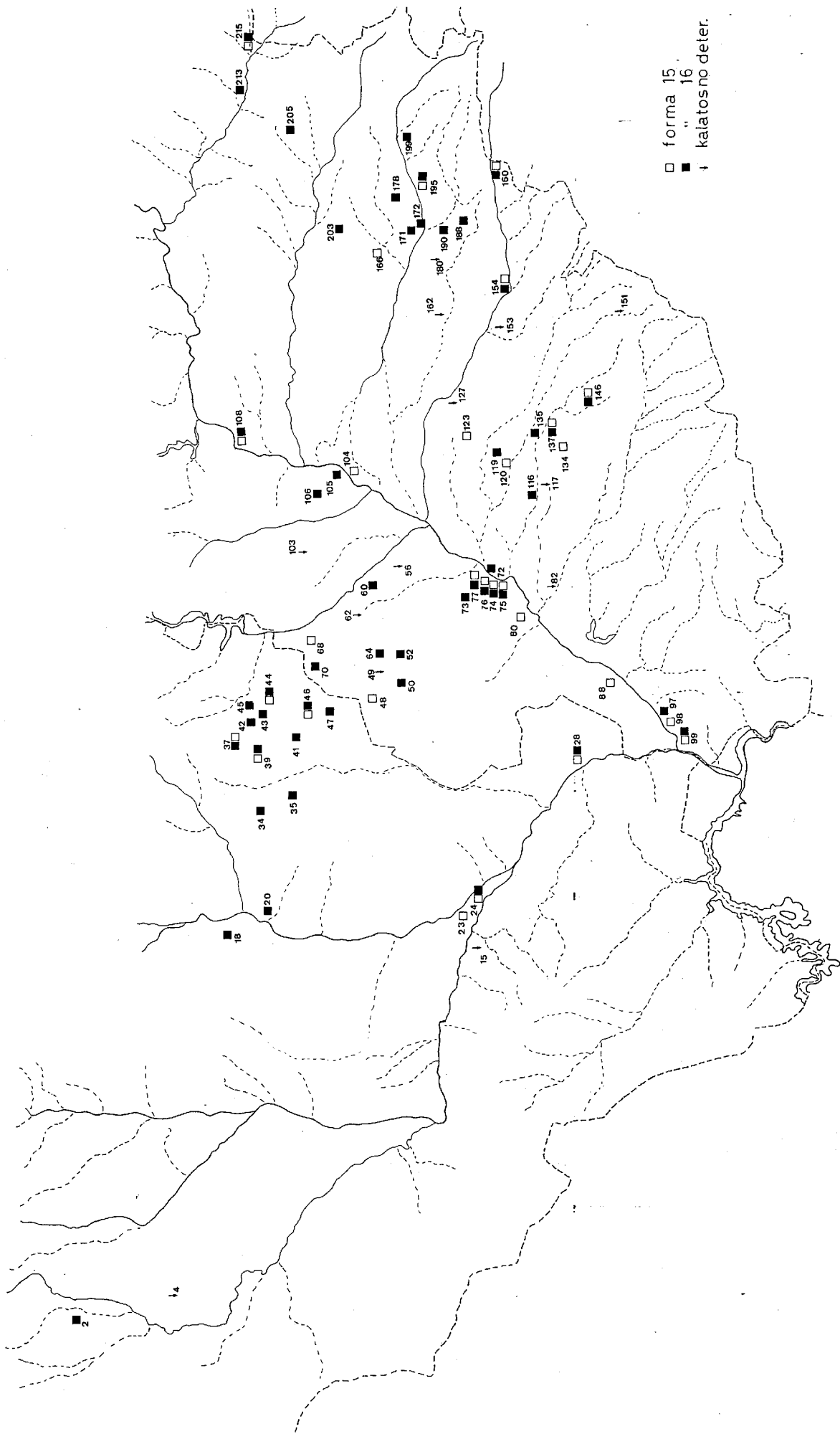

o forma 17
 ▼ " 18
 ■ " 19

FIGURA 317

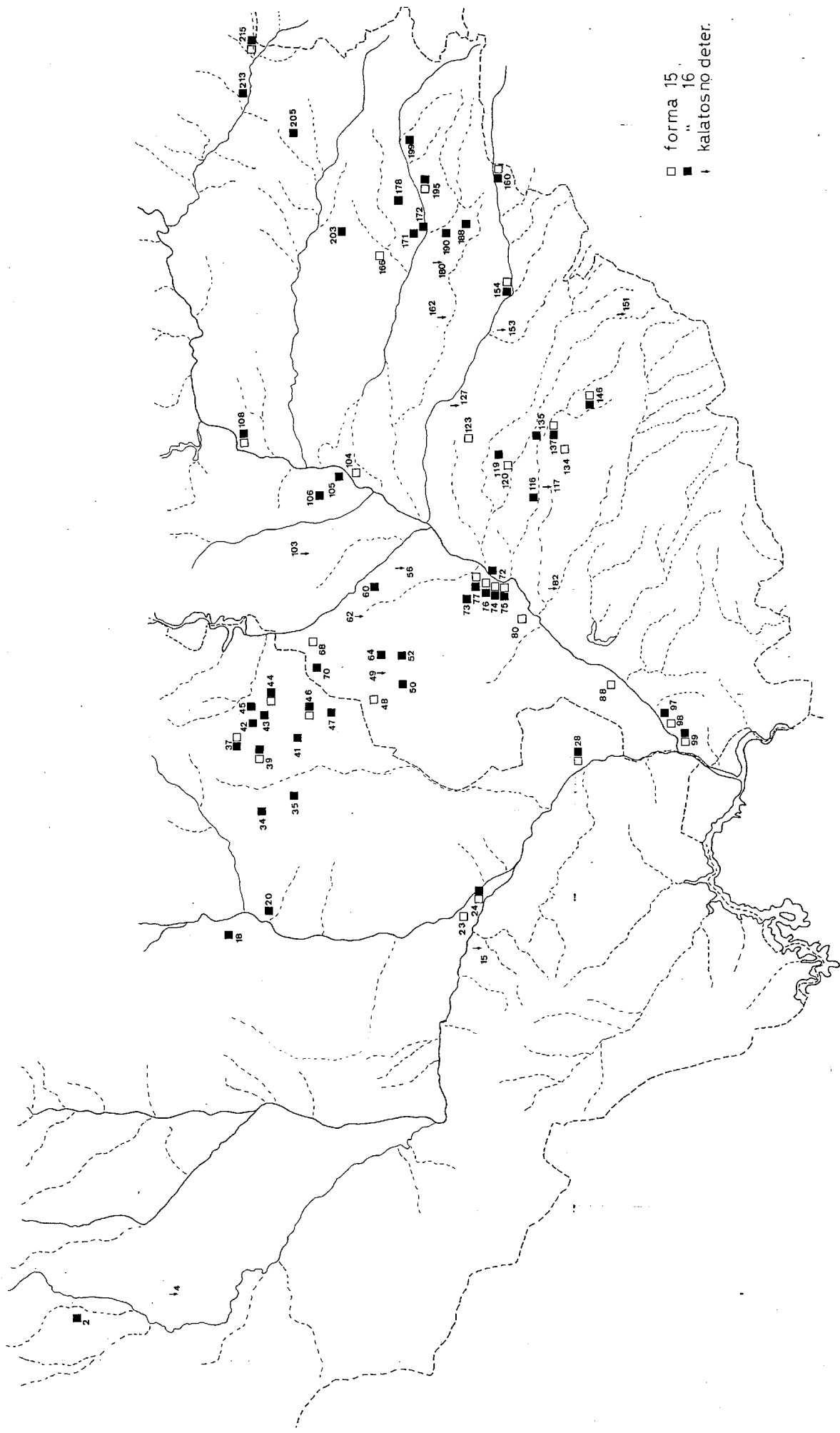
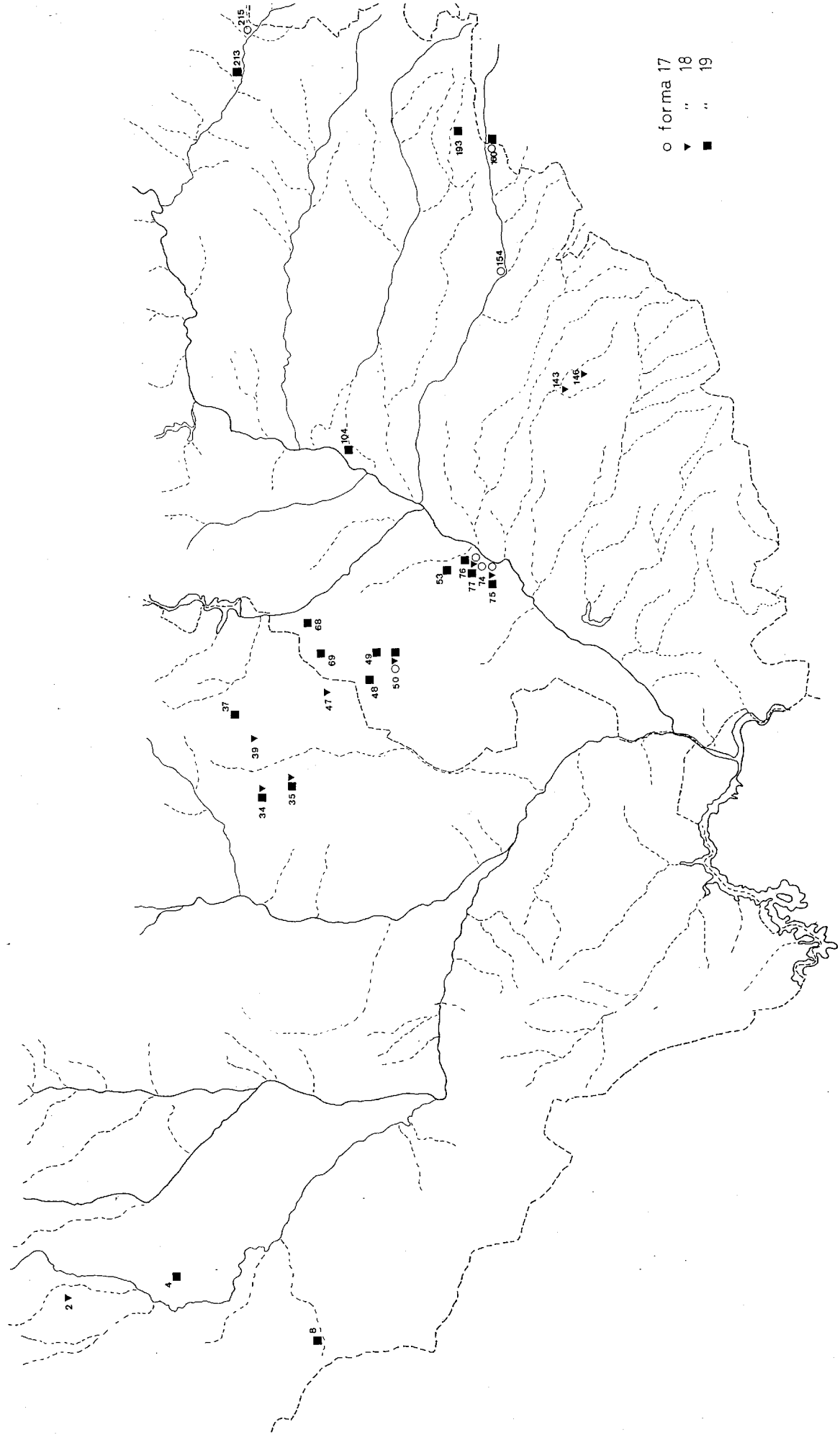

FIGURA 318



▼ forma 24
 □ " 25
 ● " 26

FIGURA 319

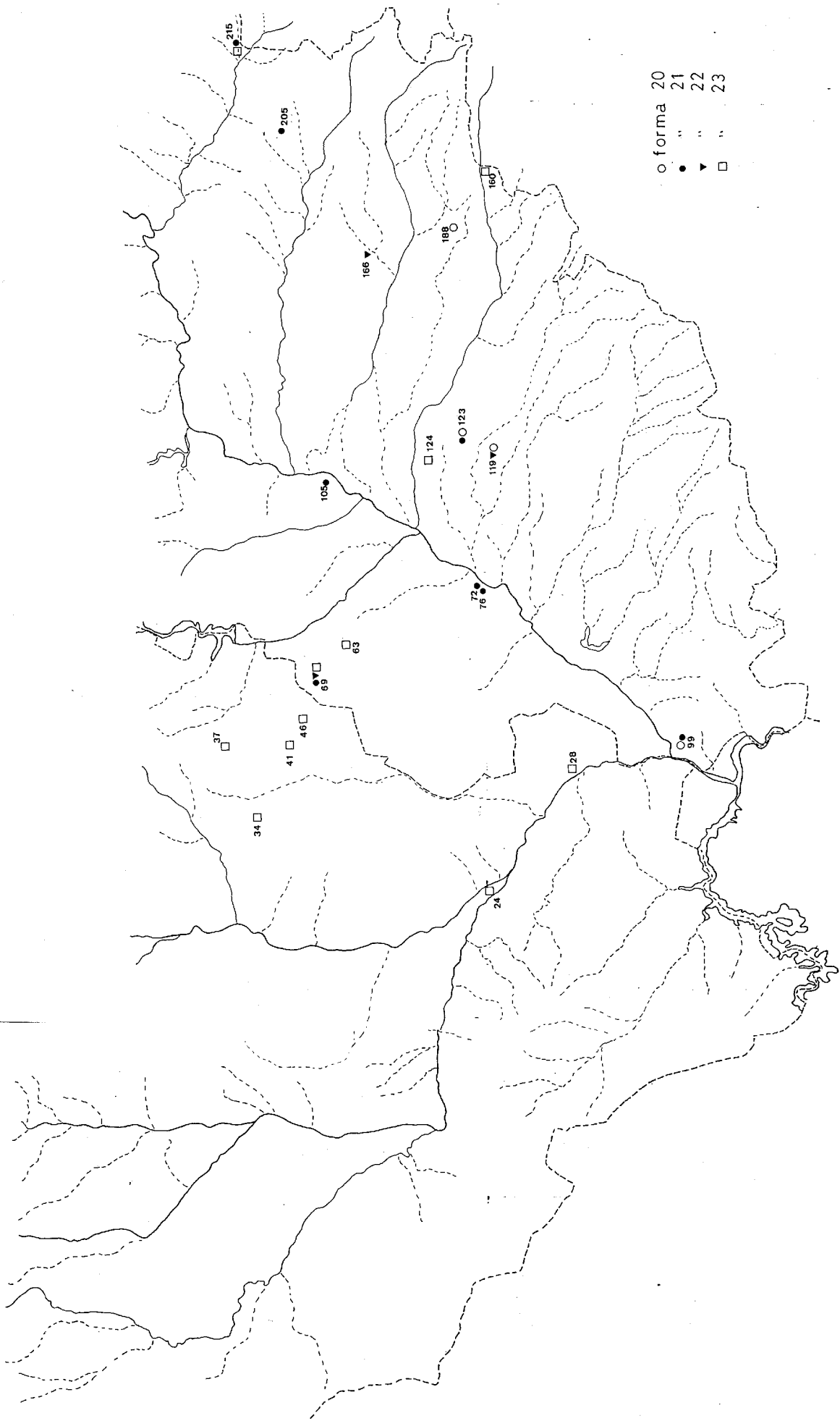
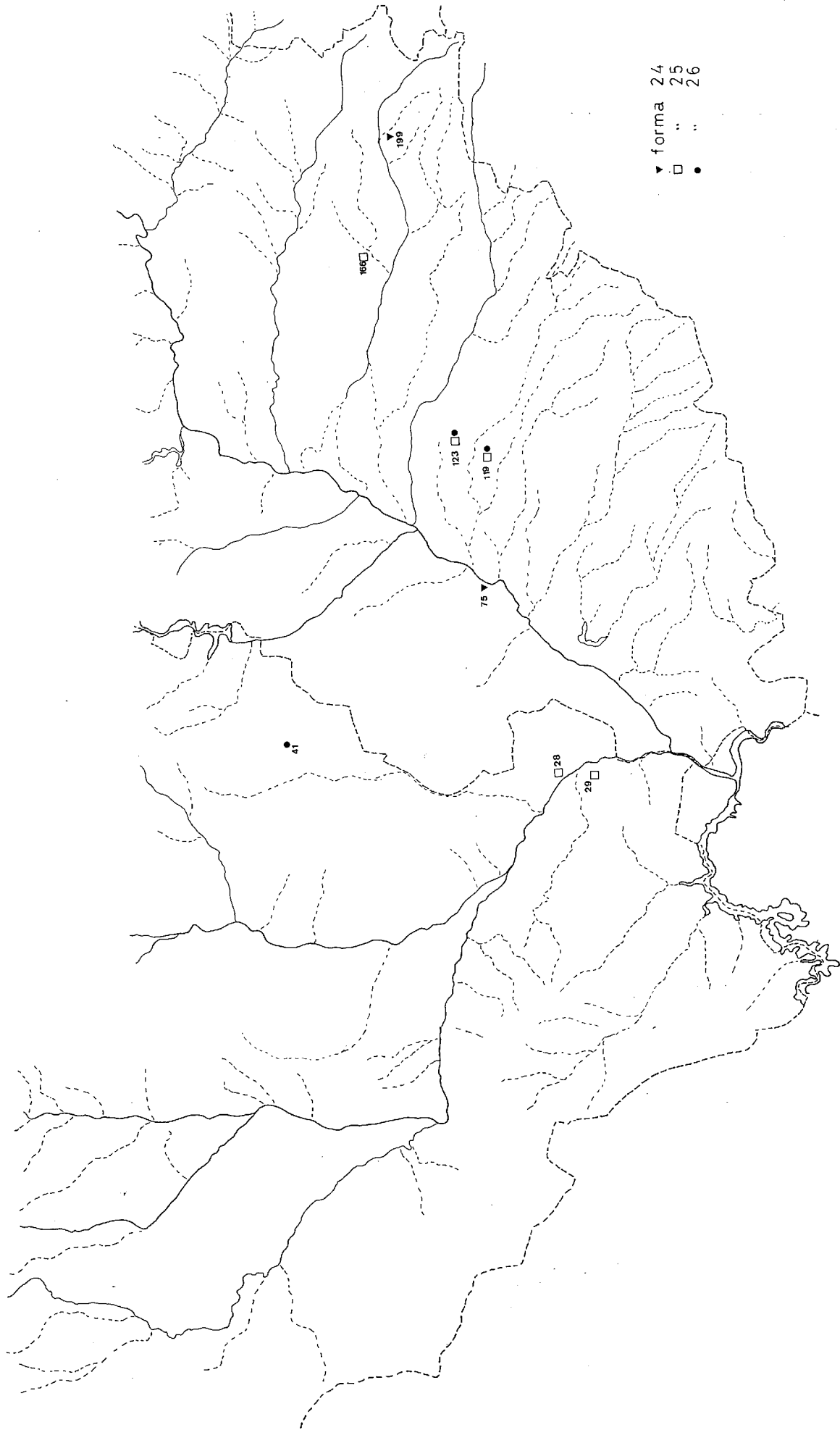

FIGURA 320



FIGURA 321

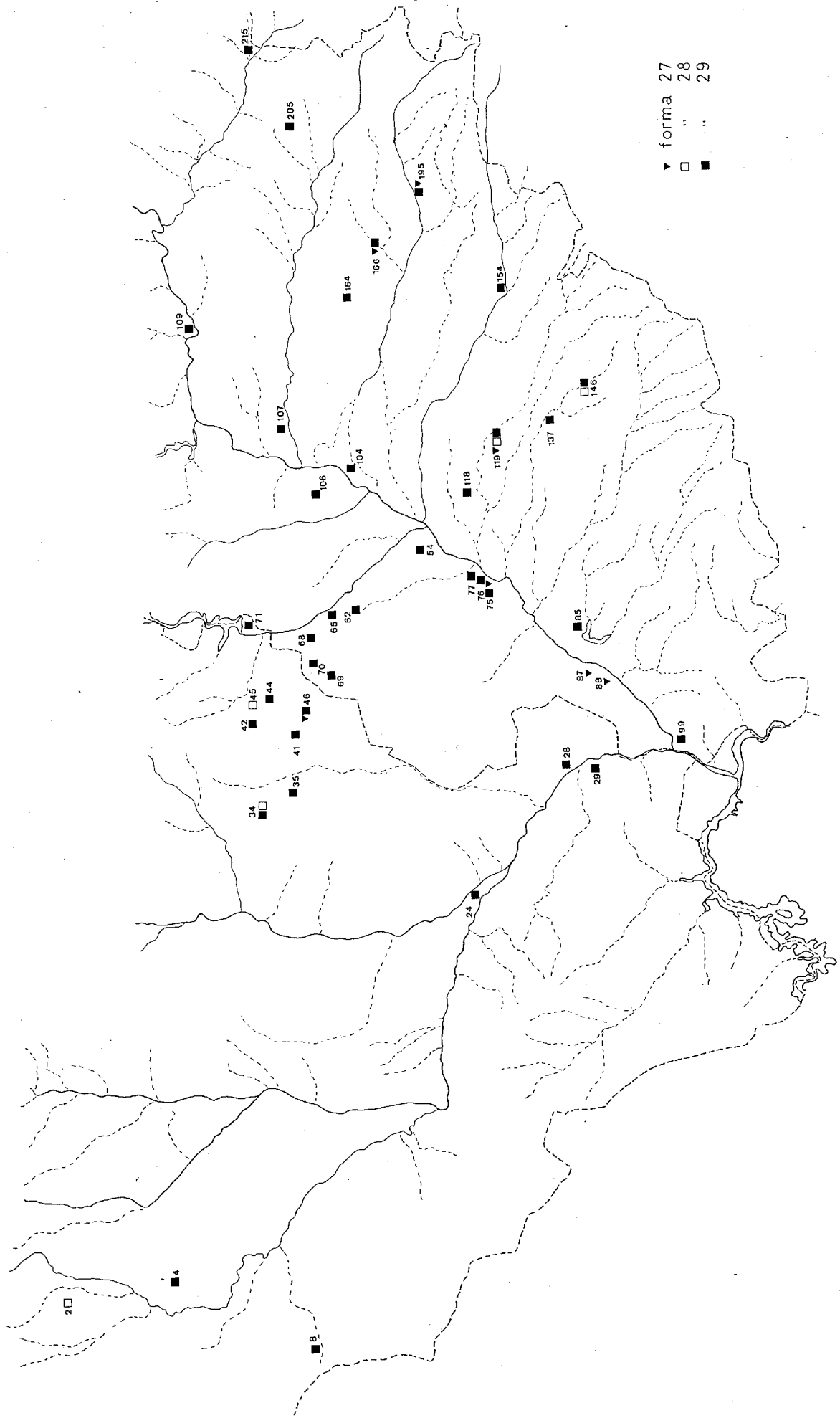

Decoracions Grup :

- † 2.1.
- 2.2.
- > 2.3.
- 2.4.
- ▲▲ 2.5.
- ▼ 2.6.
- ▼ 2.7.
- ≡ 2.8.

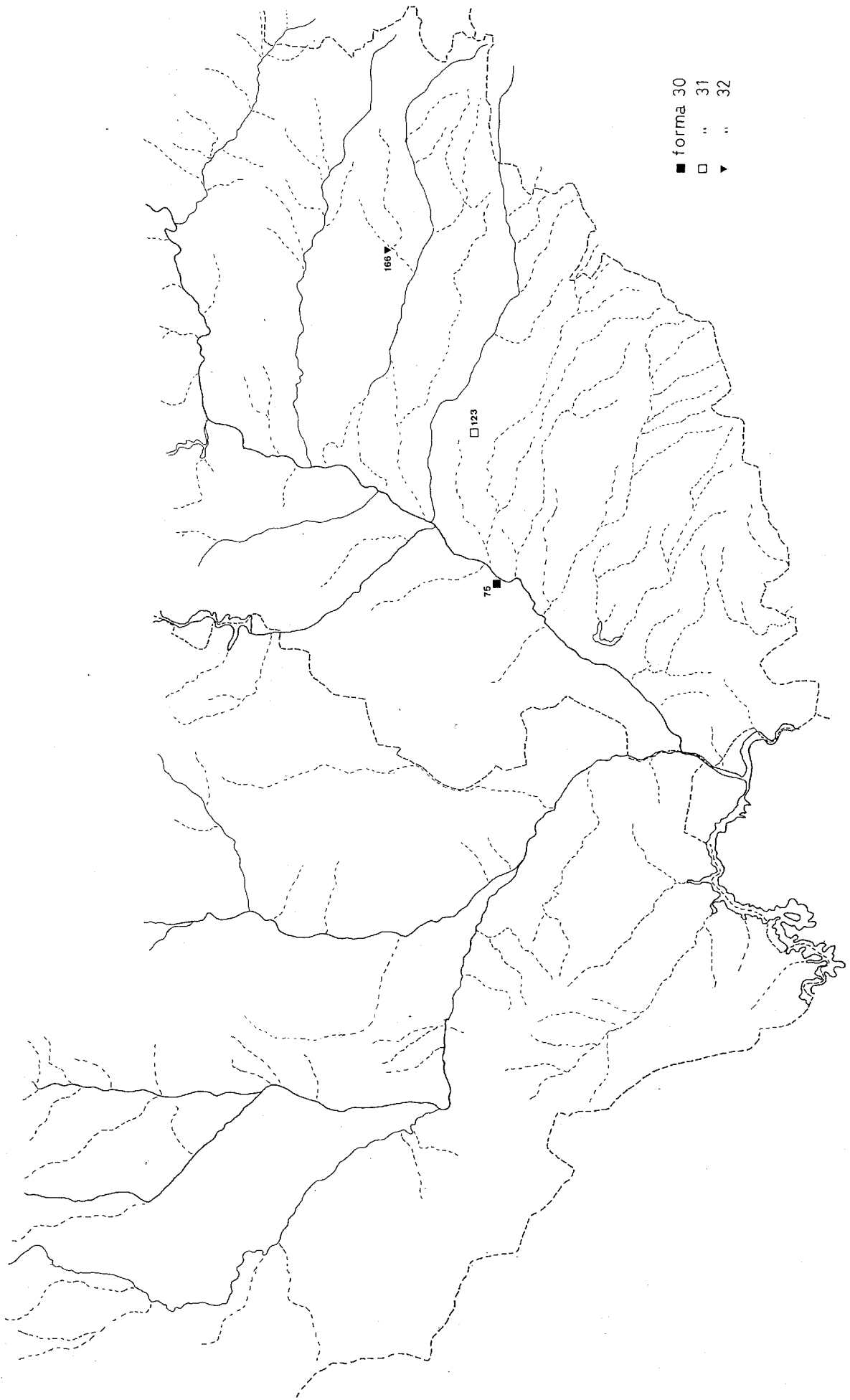
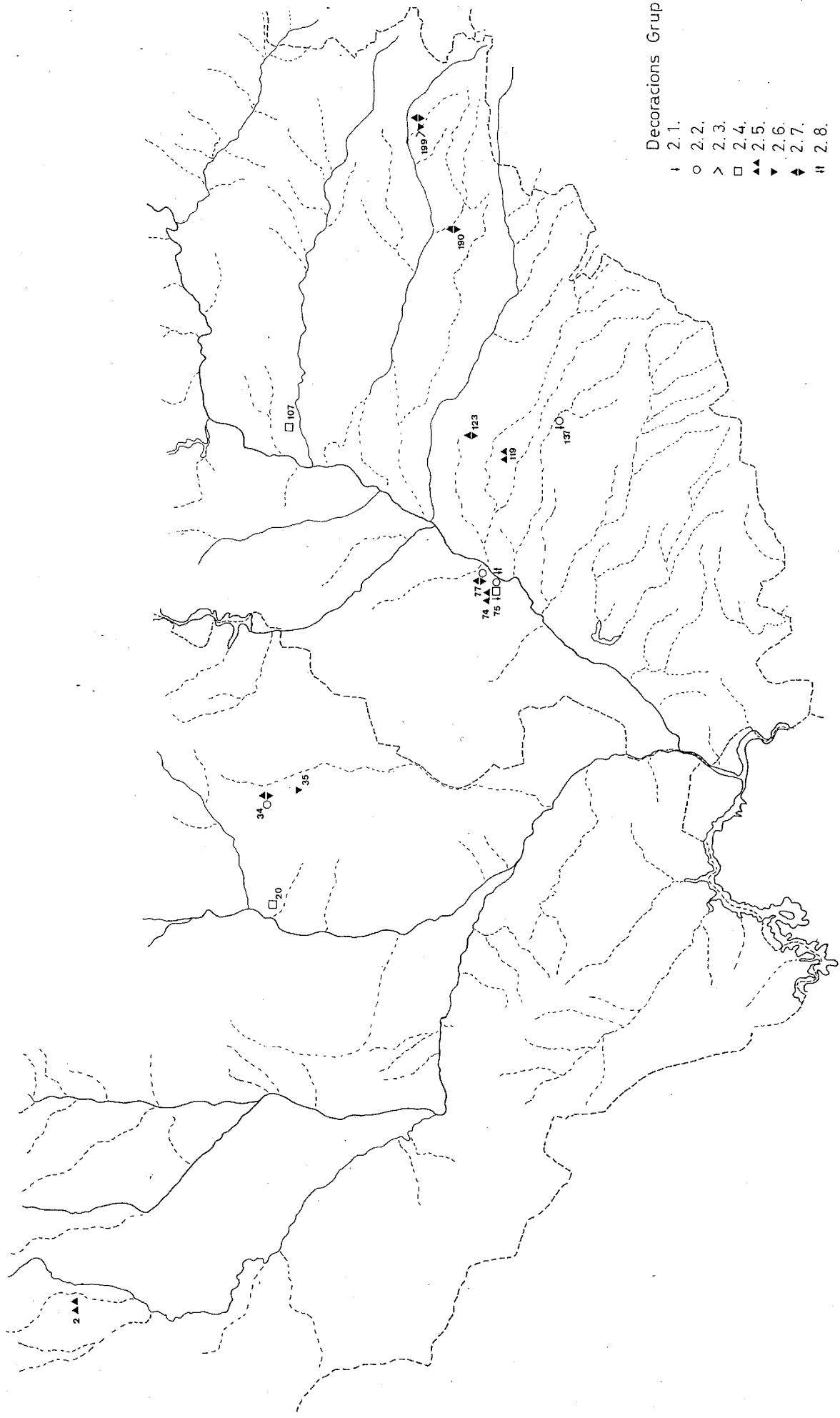
FIGURA 322



FIGURA 323



Decoracions Grup
 ● 4.1
 ▲ 4.2
 ○ 4.3
 ● 4.4
 □ 4.5

FIGURA 324

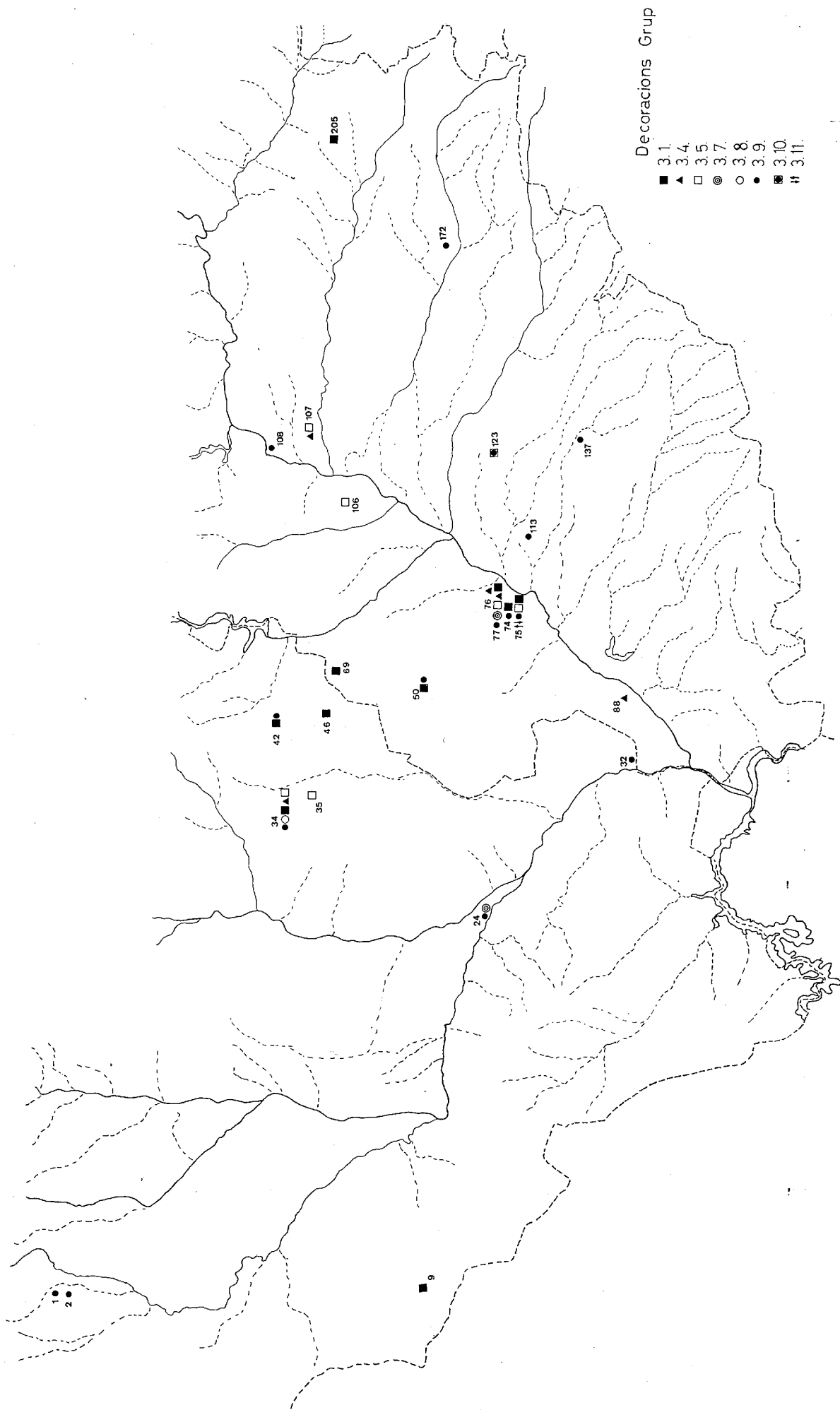
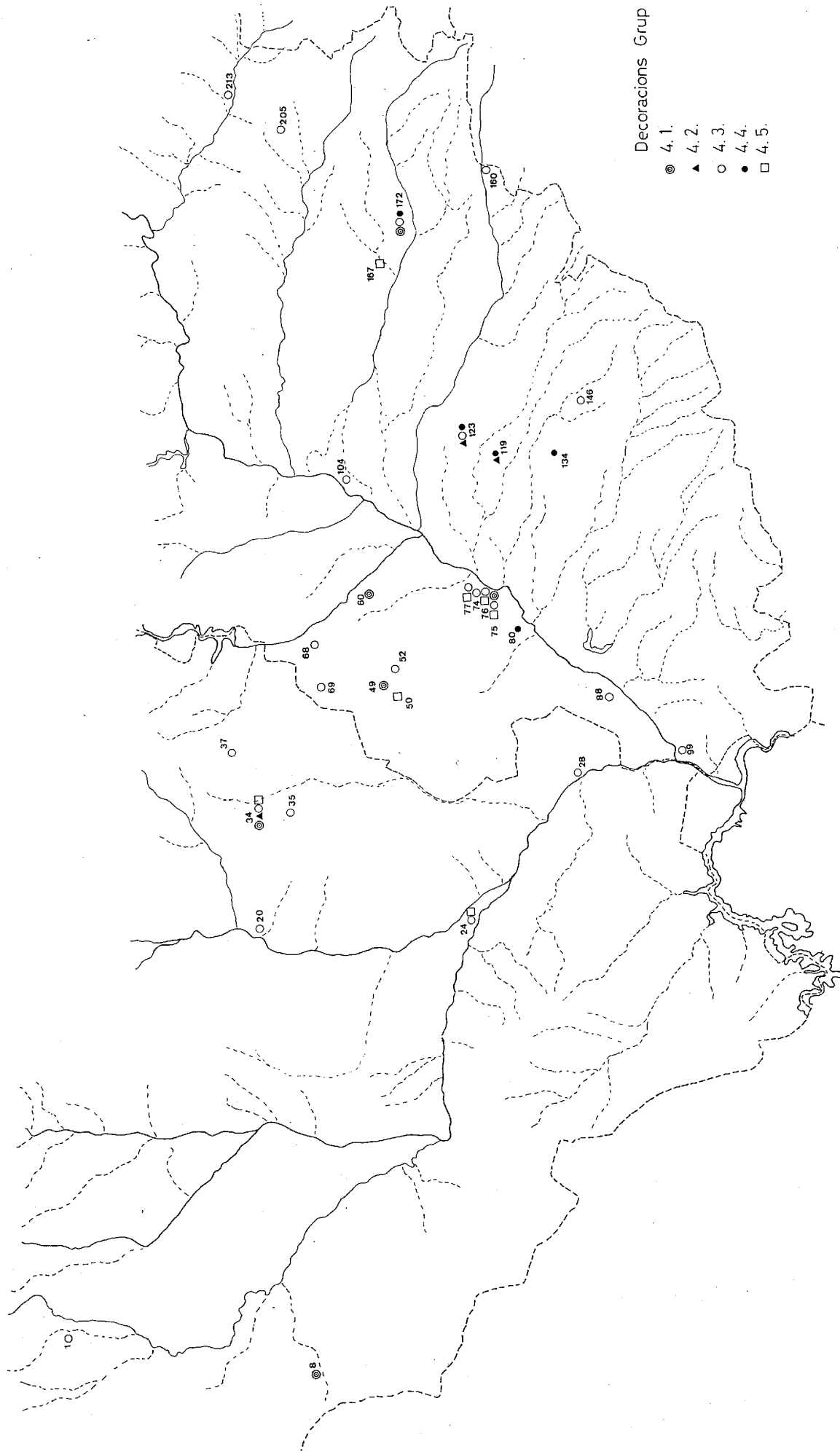
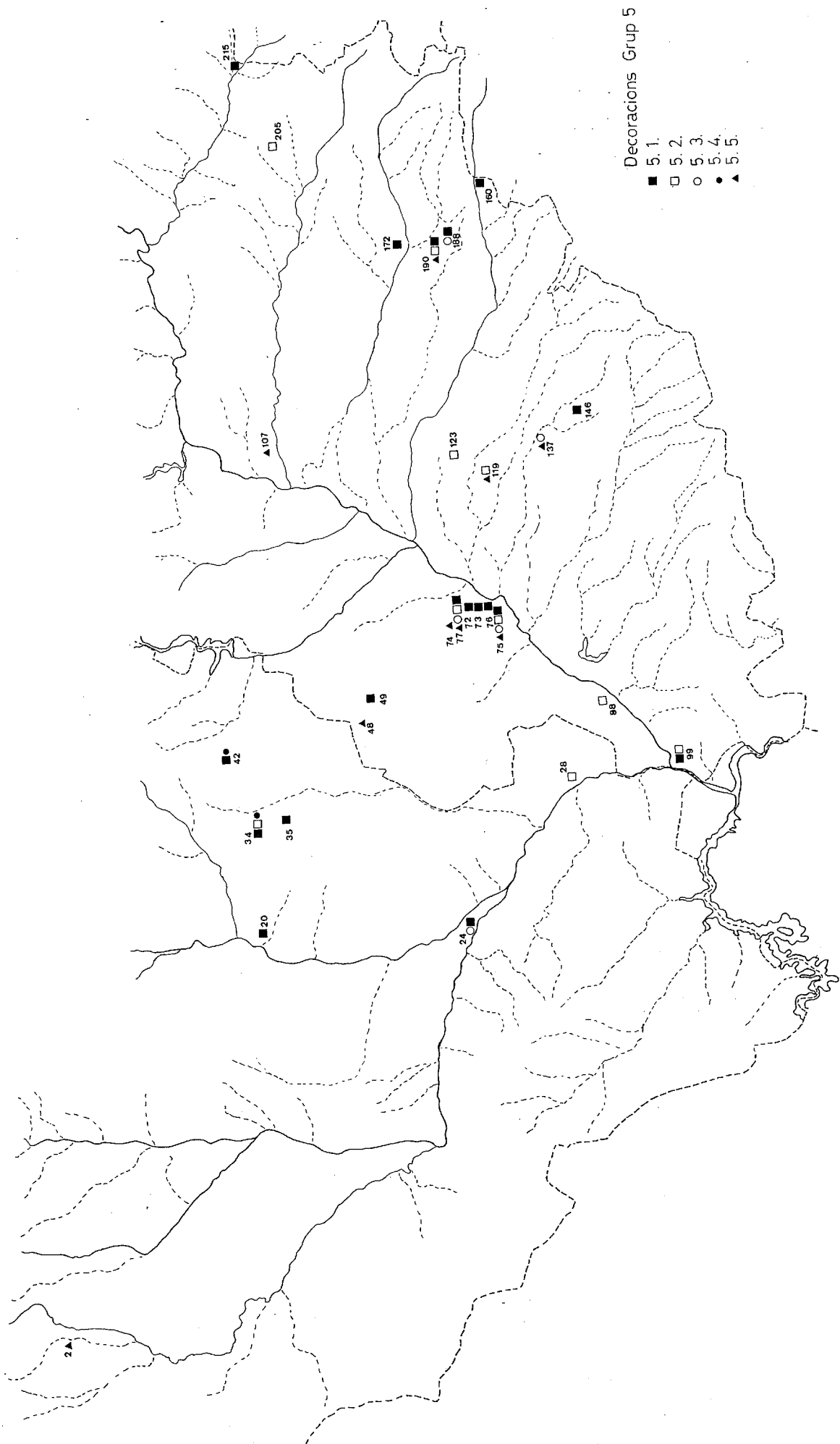

Decorations Grup 5

- 5.1
- 5.2
- 5.3
- 5.4
- ▲ 5.5

FIGURA 325



FIGURA 326



- Decoracions Grup 7
- 7.1
 - 7.2
 - ▼ 7.3
 - 7.4
 - 7.5
 - ⊥ 7.6
 - ⊙ 7.7

FIGURA 327

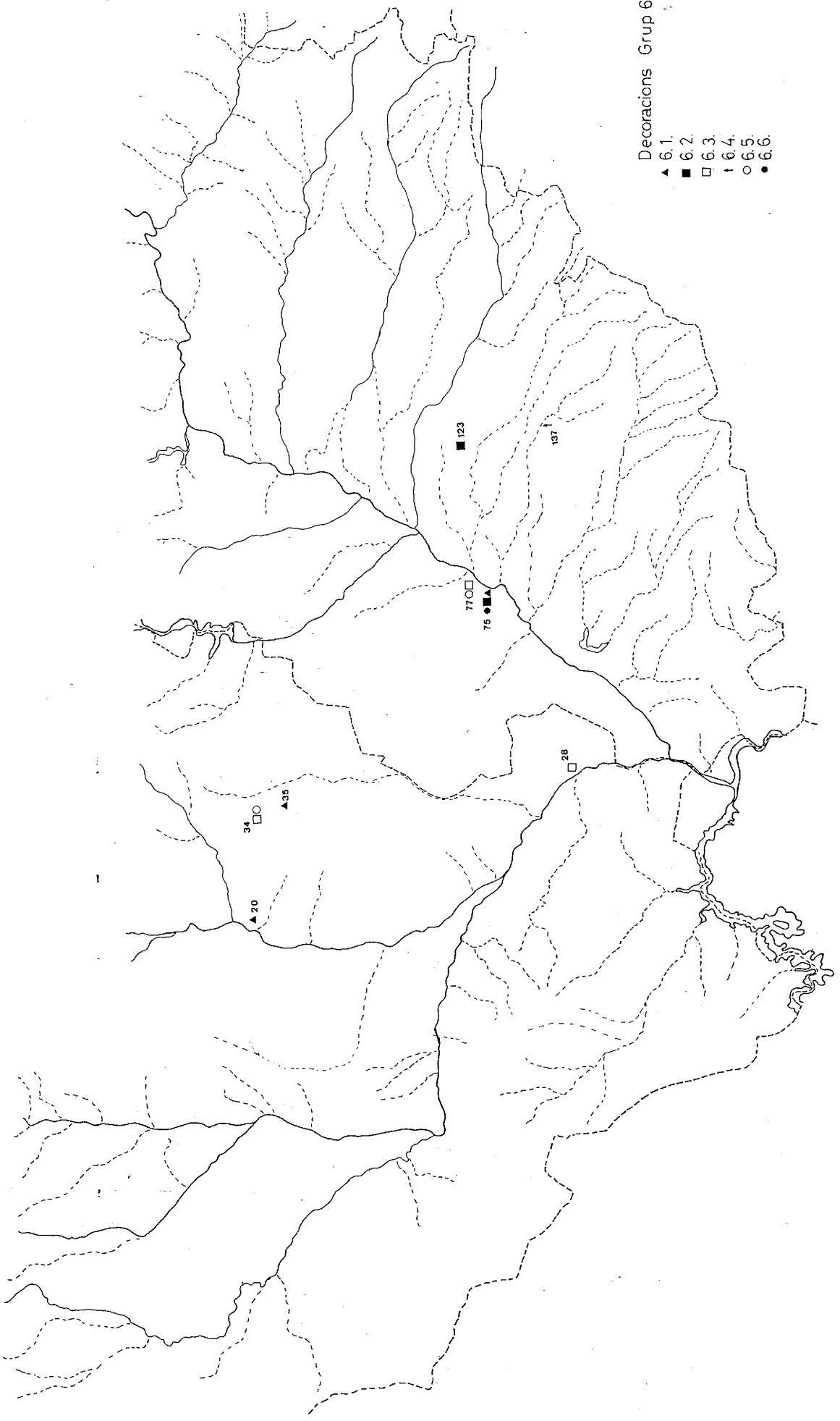
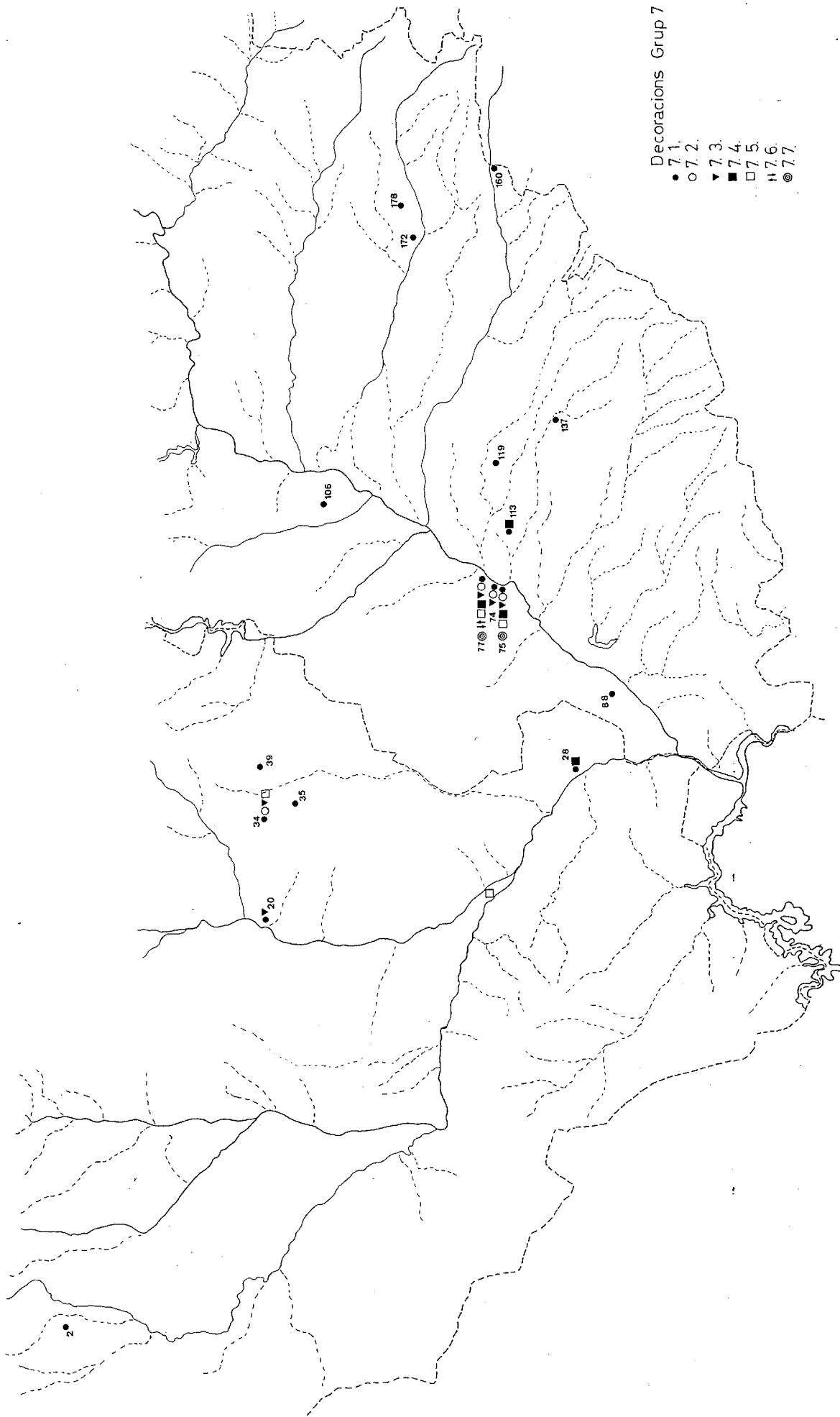
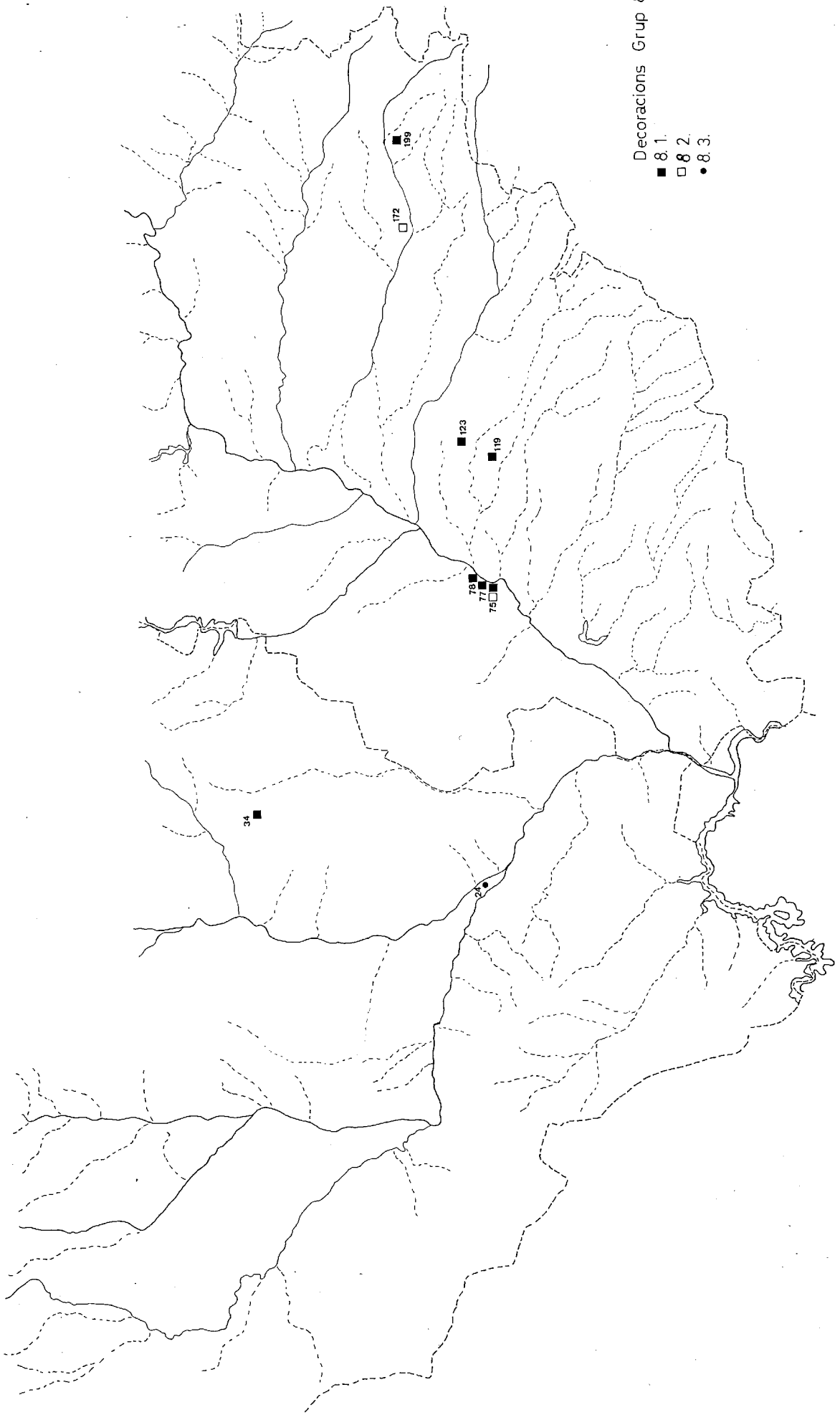

Decoracions Grup 8

- 8.1
- 8.2
- 8.3

FIGURA 328

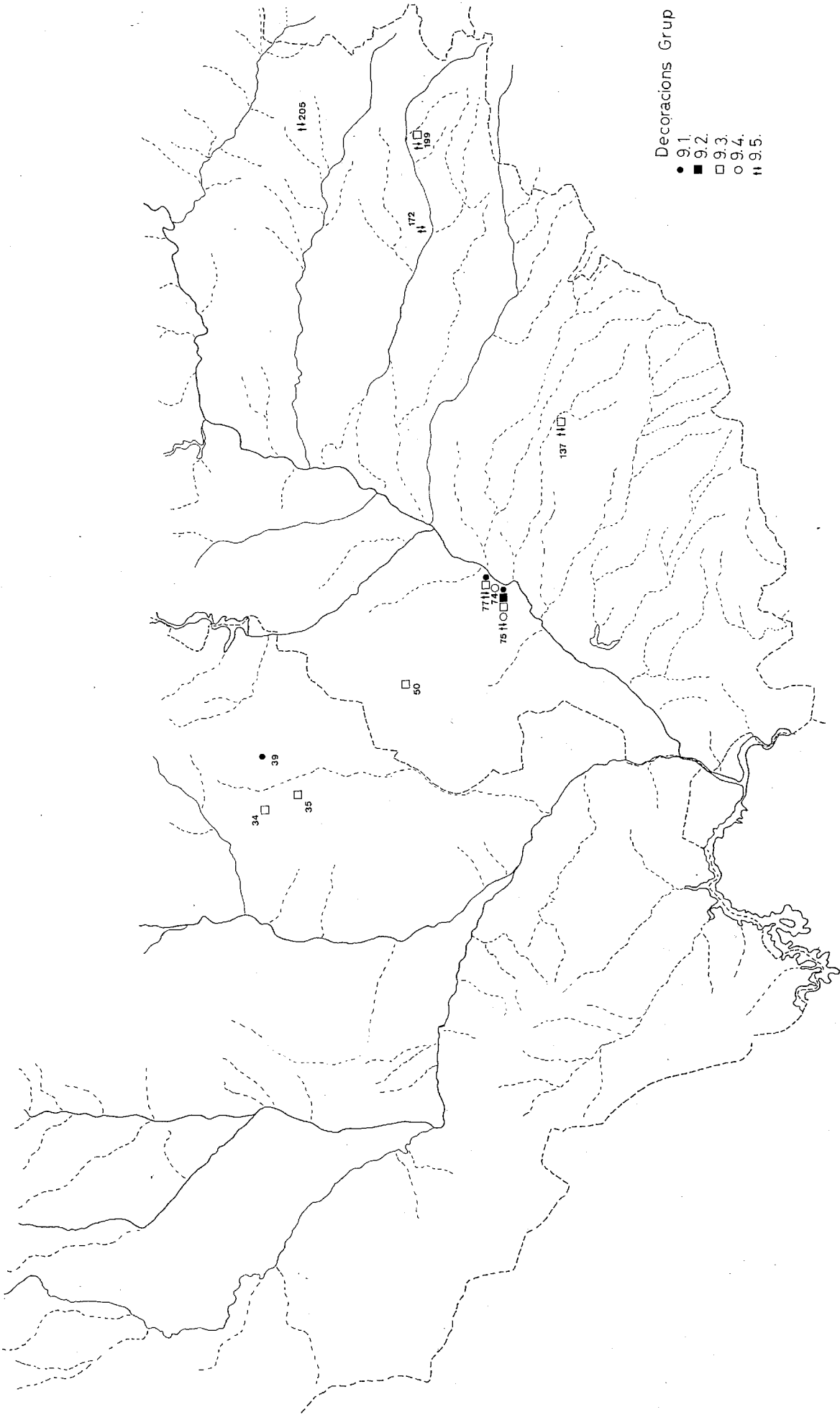

Decoracions Grup 9

- 9.1
- 9.2
- 9.3
- 9.4
- 9.5

FIGURA 329

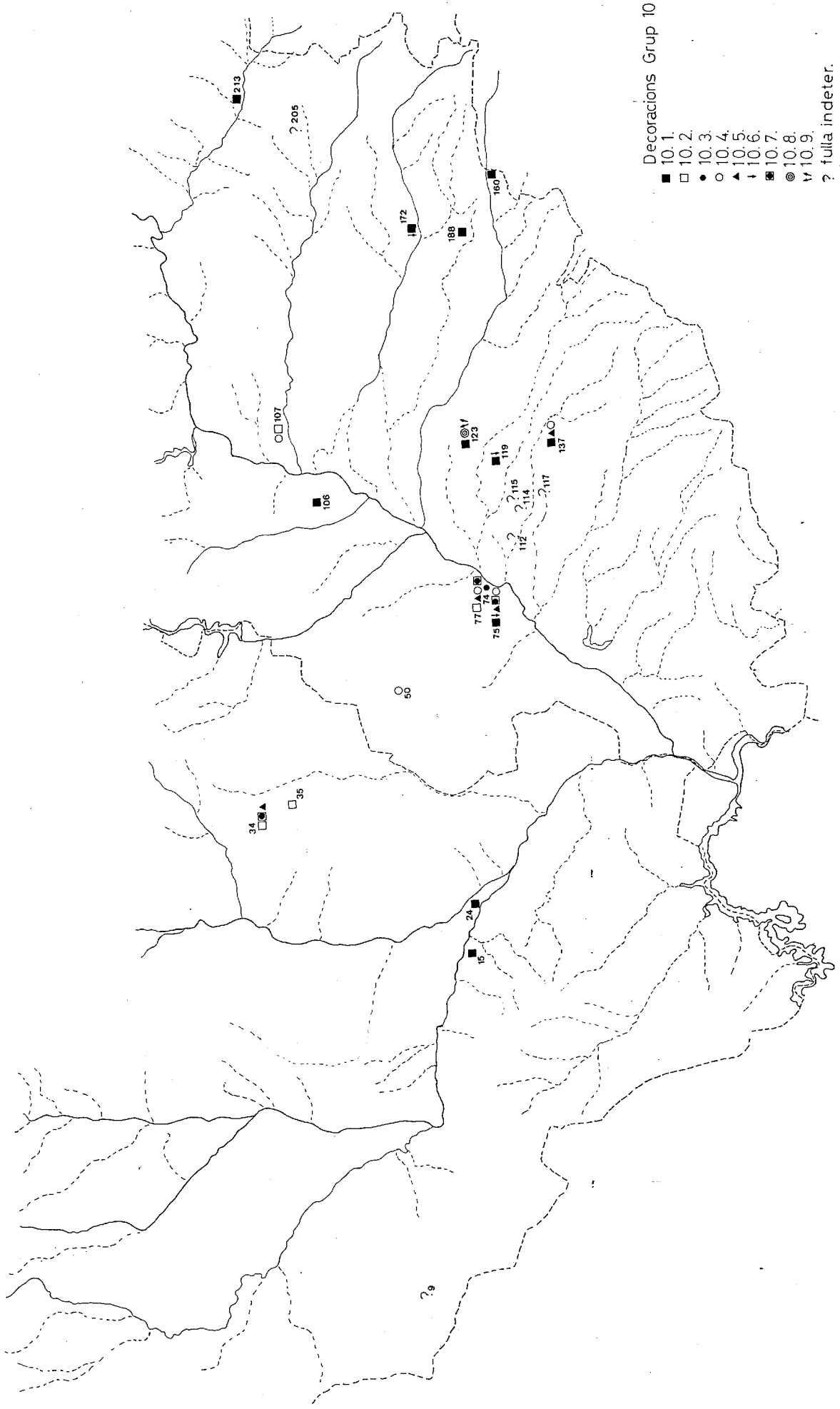

- Decoracions Grup 10
- 10.1.
 - 10.2.
 - 10.3.
 - 10.4.
 - ▲ 10.5.
 - △ 10.6.
 - 10.7.
 - 10.8.
 - ▽ 10.9.
 - ? fulla indeter.

FIGURA 330



FIGURA 331



- Decorations Group 12
- ▲ 12.1
 - ↓ 12.2
 - ≡ 12.3
 - 12.4
 - 12.5
 - 12.6
 - 12.7
 - ◻ 12.8

FIGURA 332

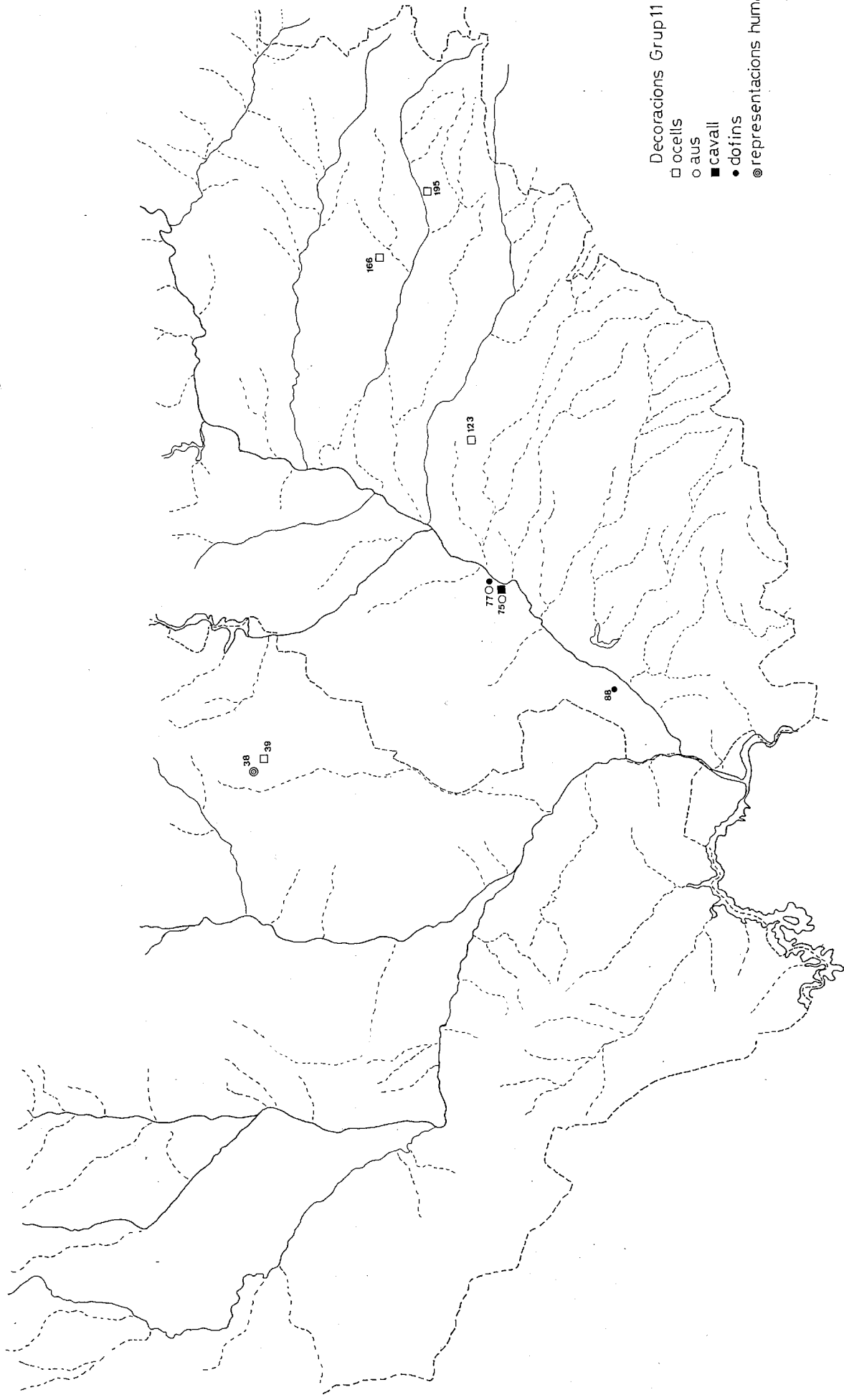
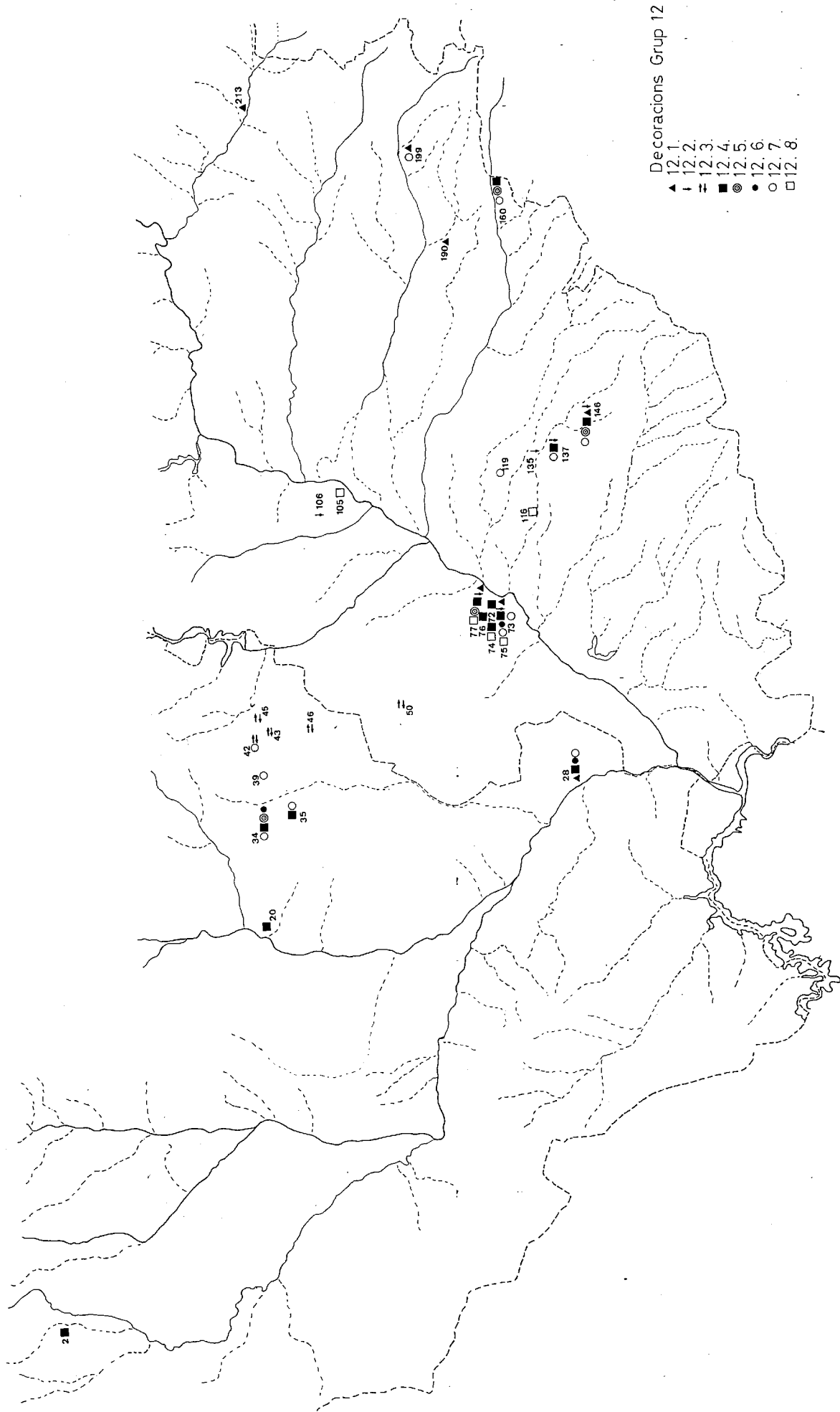
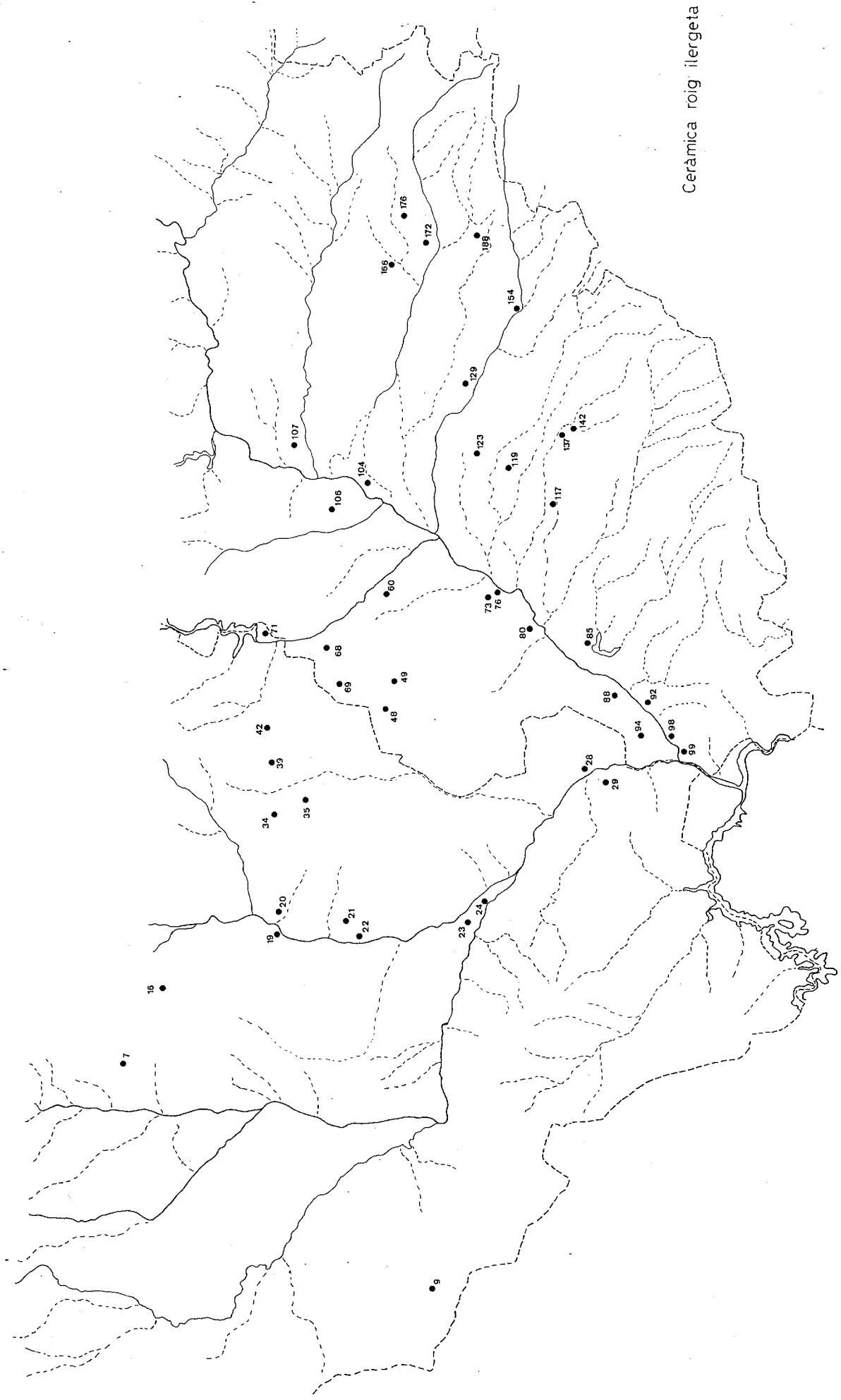

Ceràmica roig ilergeta

FIGURA 333



FIGURA 334



FIGURA 335

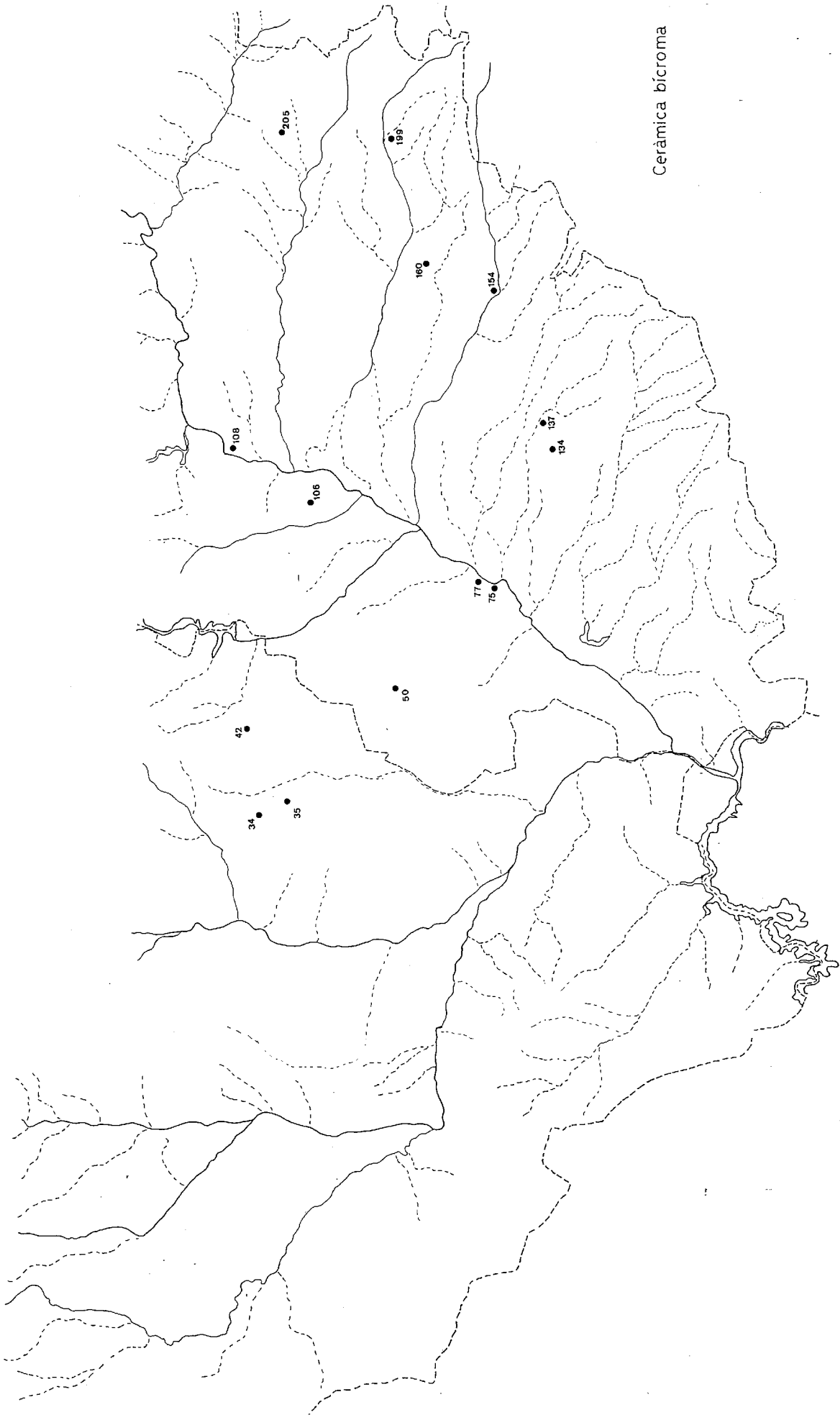

FOTOGRAFIA 1

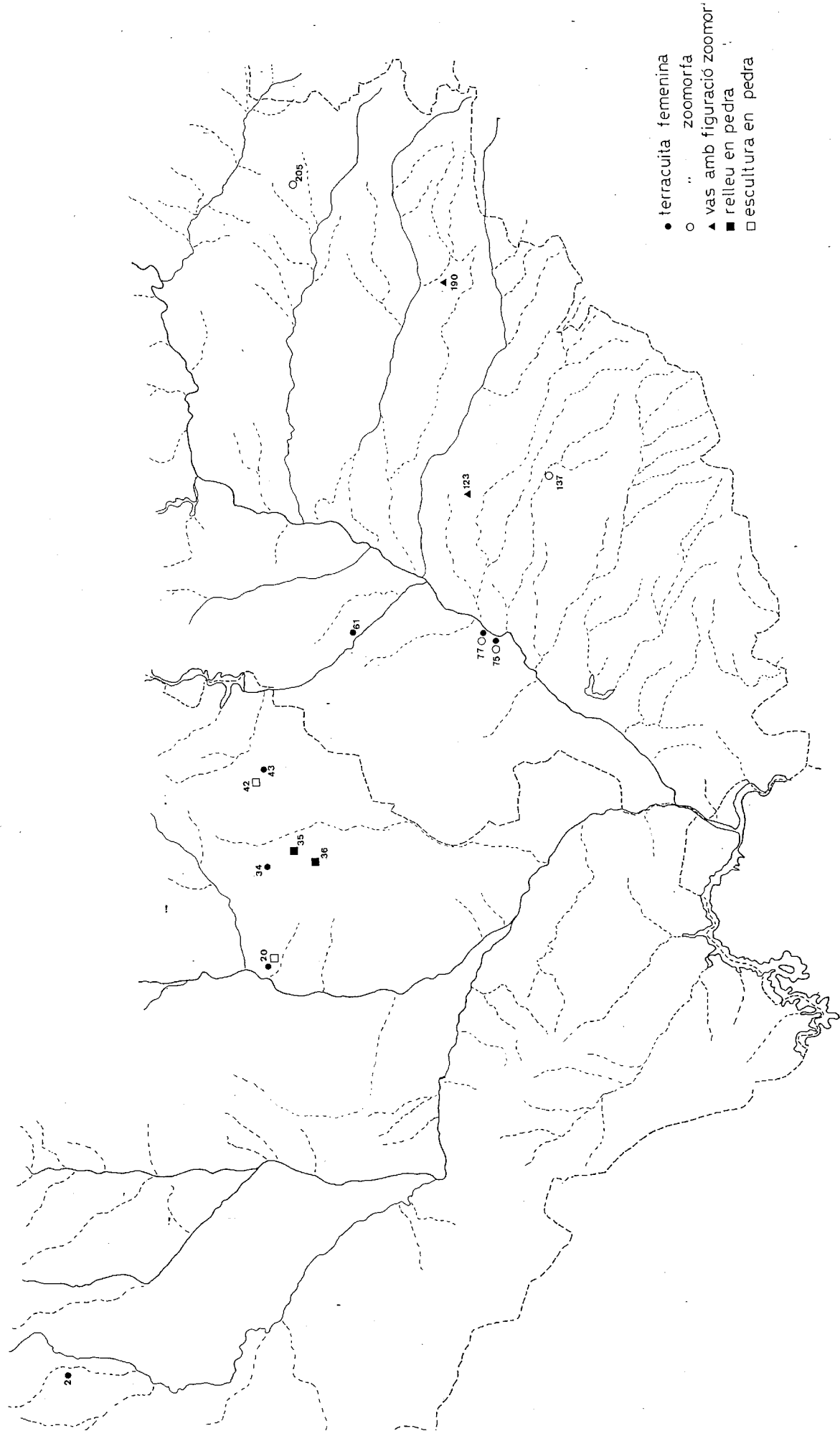
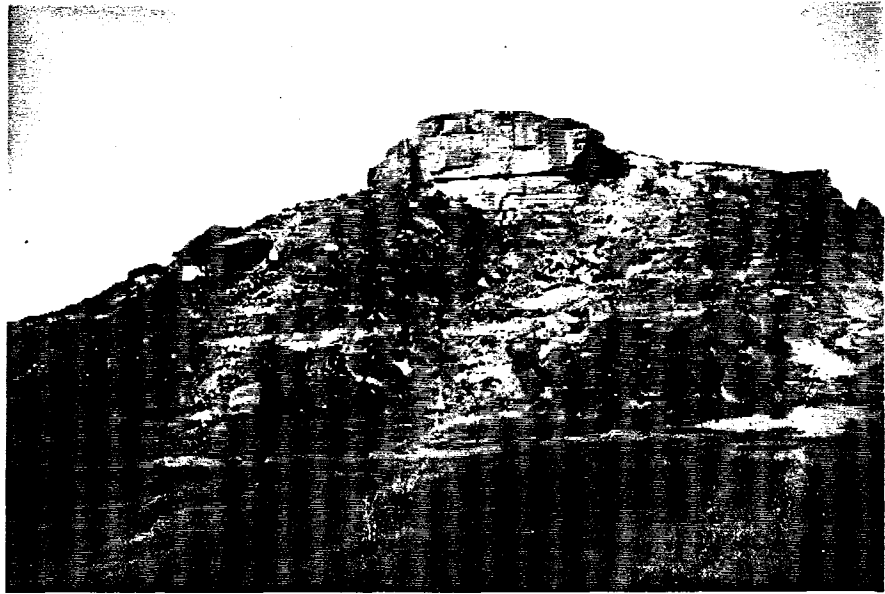
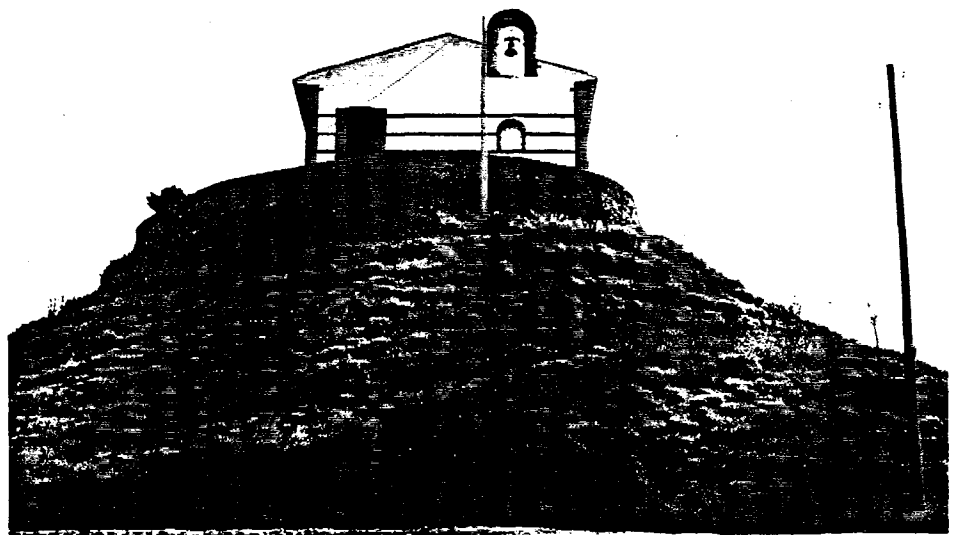

FOTOGRAFIA 2

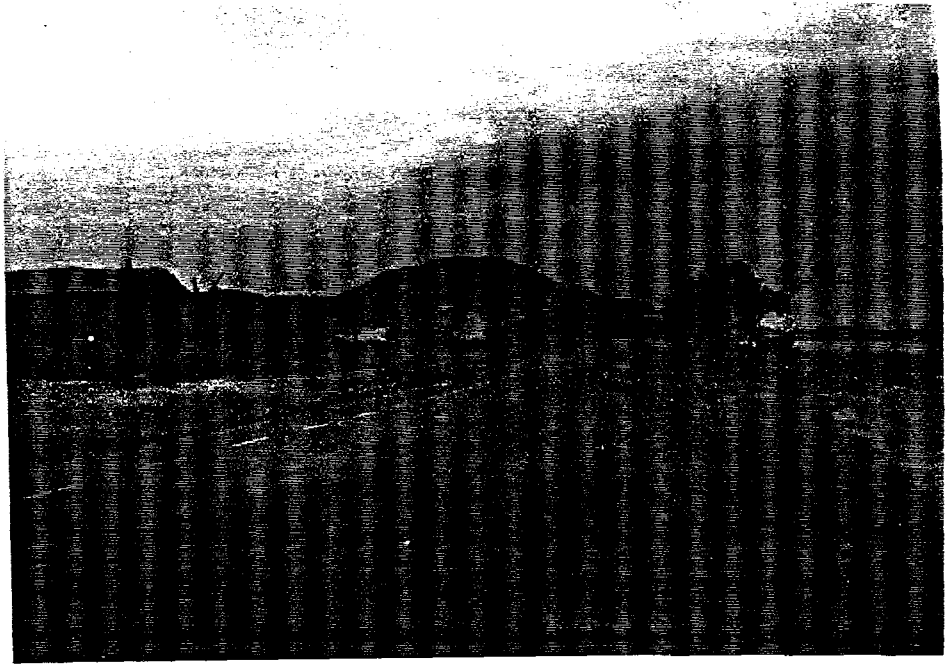

FOTOGRAFIA 3



FOTOGRAFIA 4

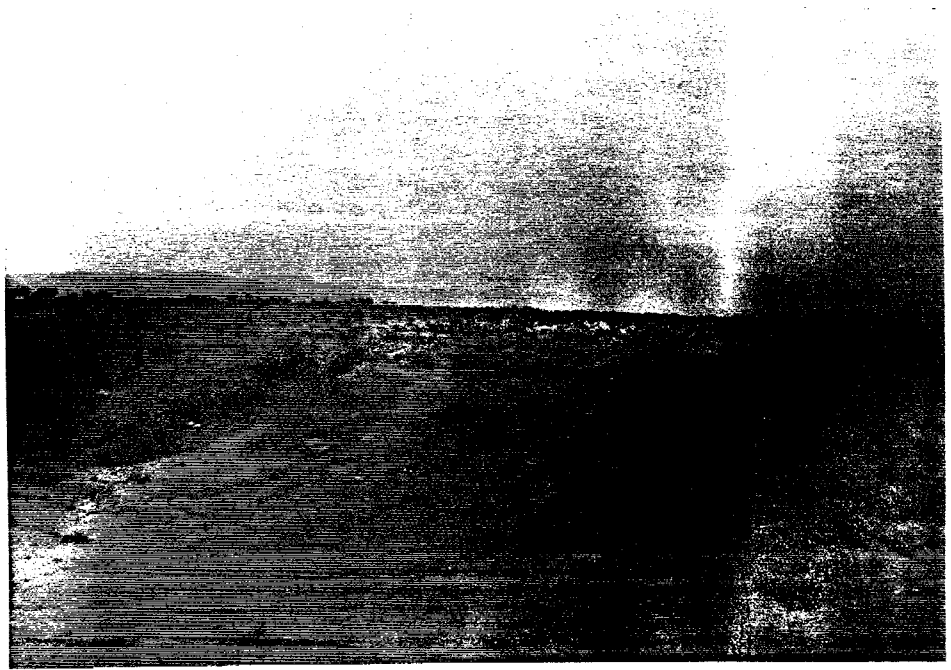

FOTOGRAFIA 5

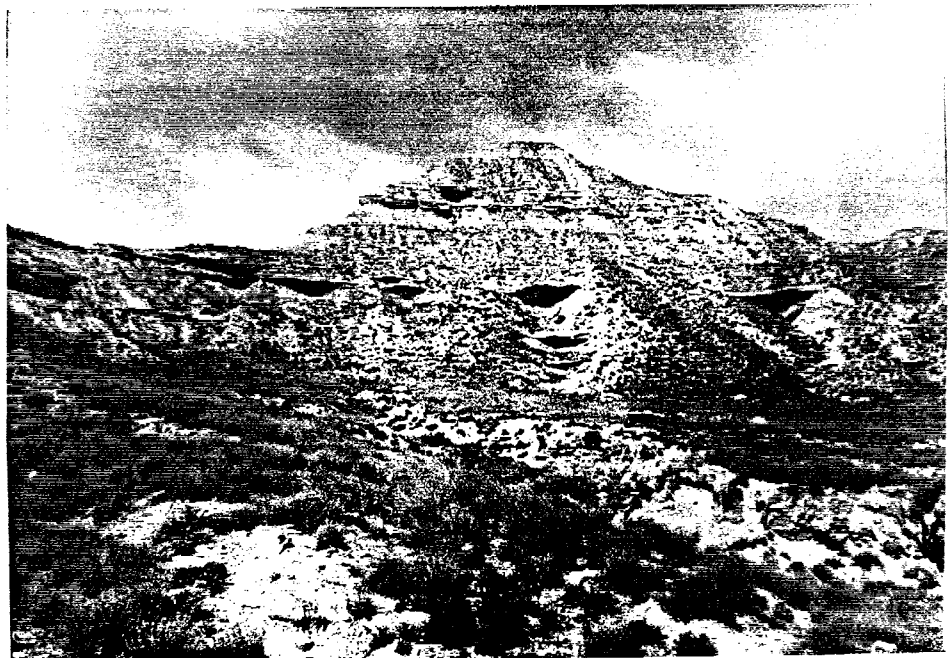

FOTOGRAFIA 6



FOTOGRAFIA 7



FOTOGRAFIA 8



FOTOGRAFIA 9

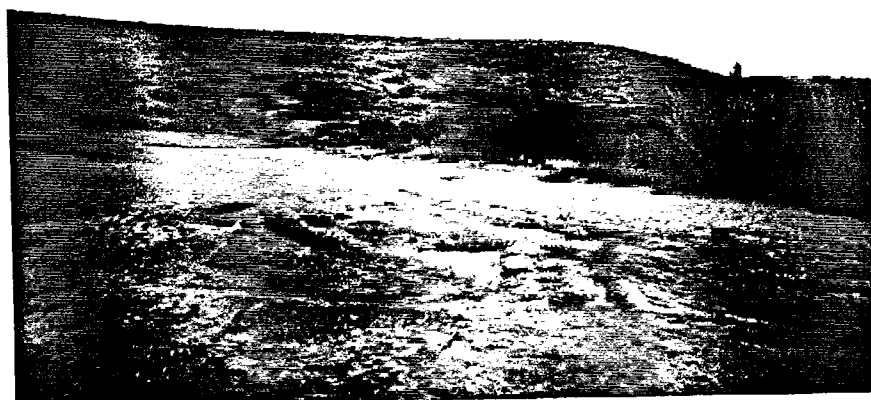

FOTOGRAFIA 10

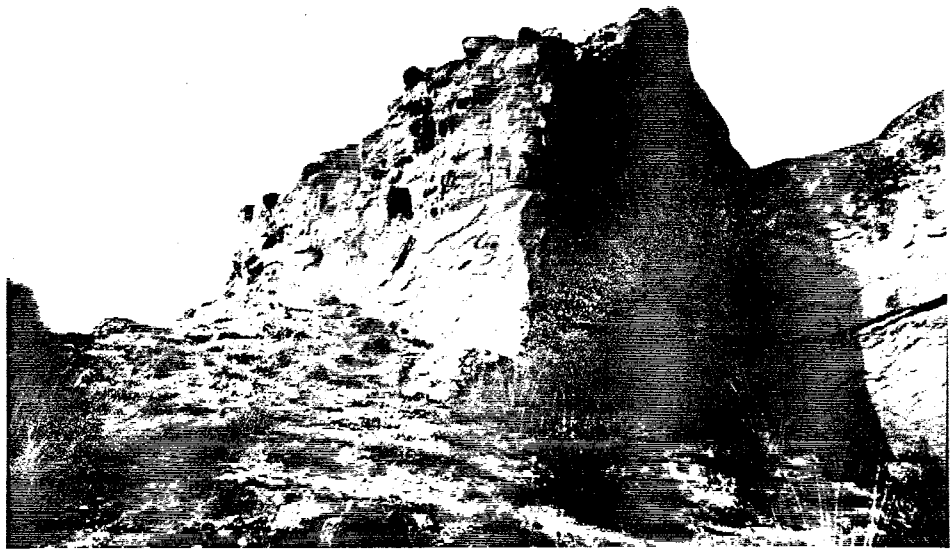

FOTOGRAFIA 11



FOTOGRAFIA 12

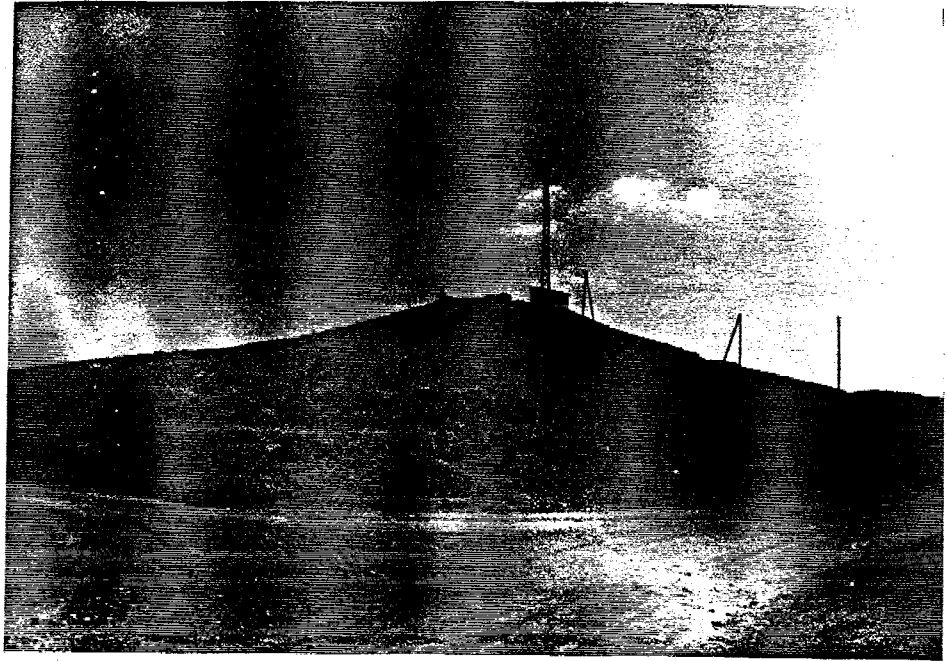

FOTOGRAFIA 13



FOTOGRAFIA 14



FOTOGRAFIA 15



FOTOGRAFIA 16



FOTOGRAFIA 17

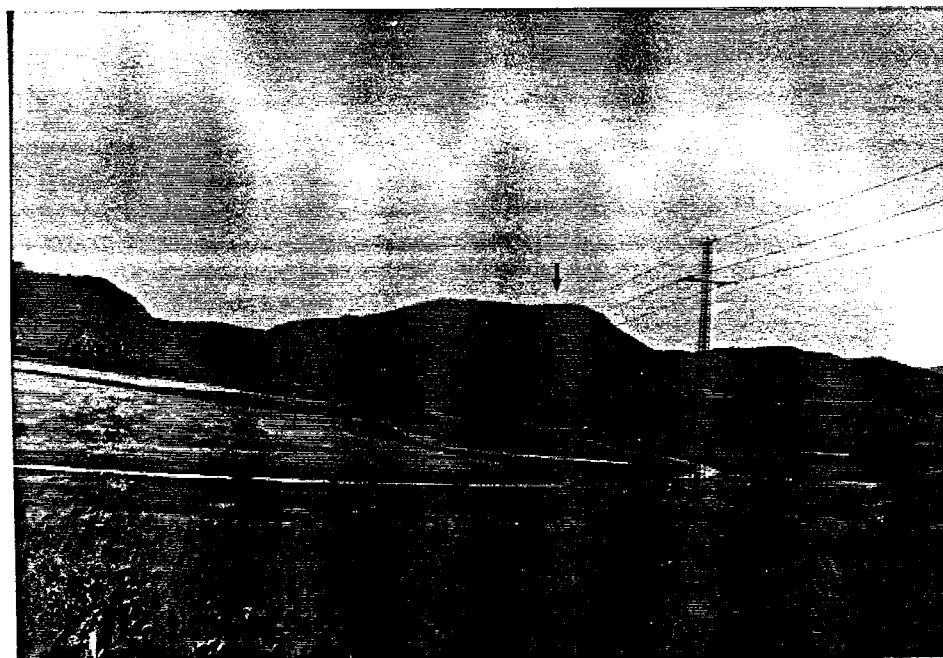

FOTOGRAFIA 18

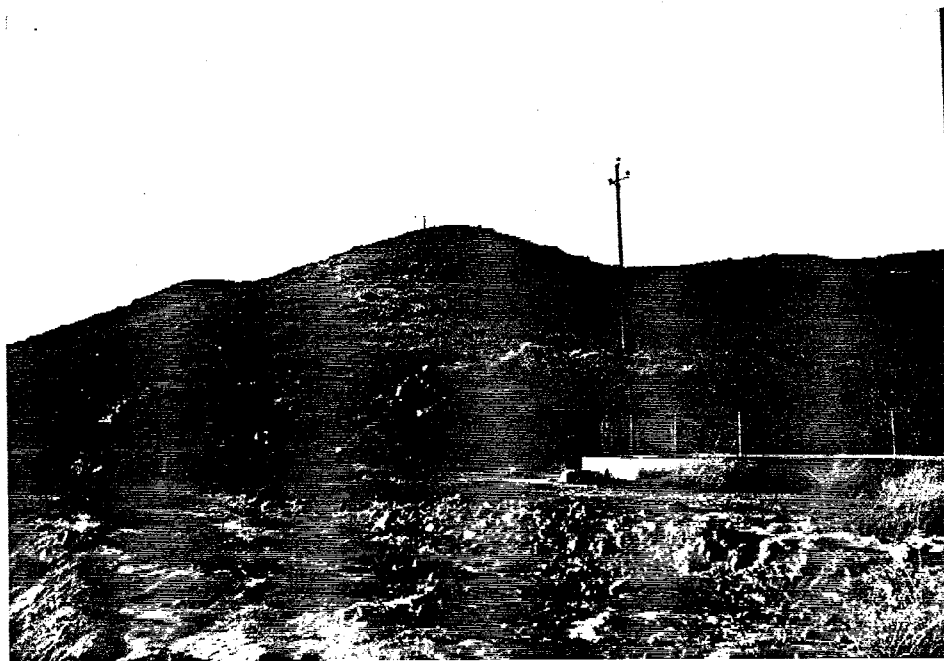

FOTOGRAFIA 19

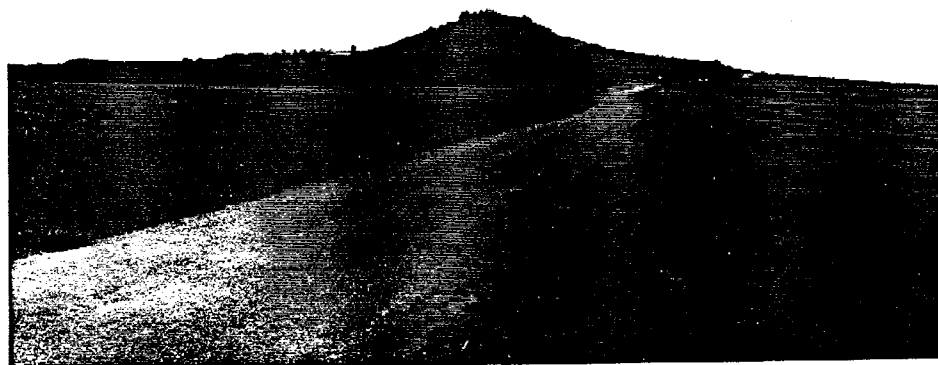

FOTOGRAFIA 20



FOTOGRAFIA 21



FOTOGRAFIA 22

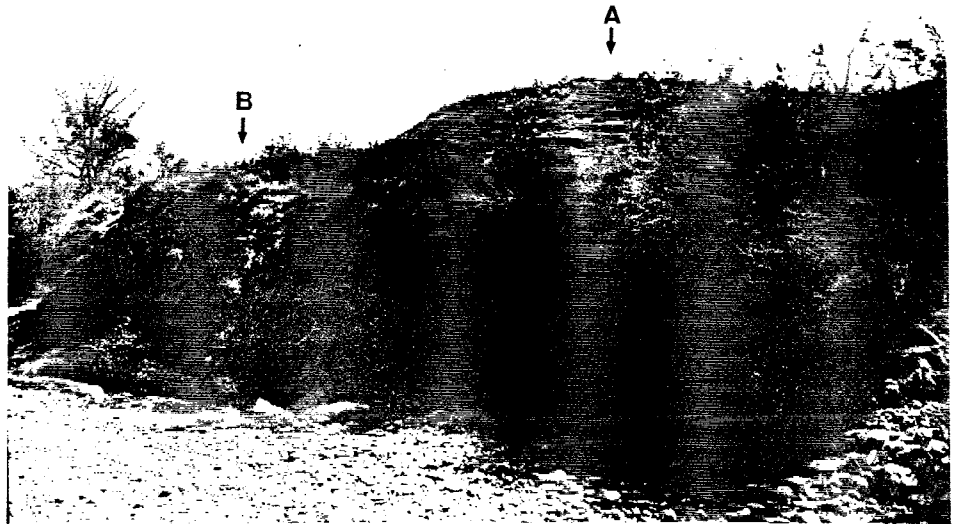

FOTOGRAFIA 23



FOTOGRAFIA 24

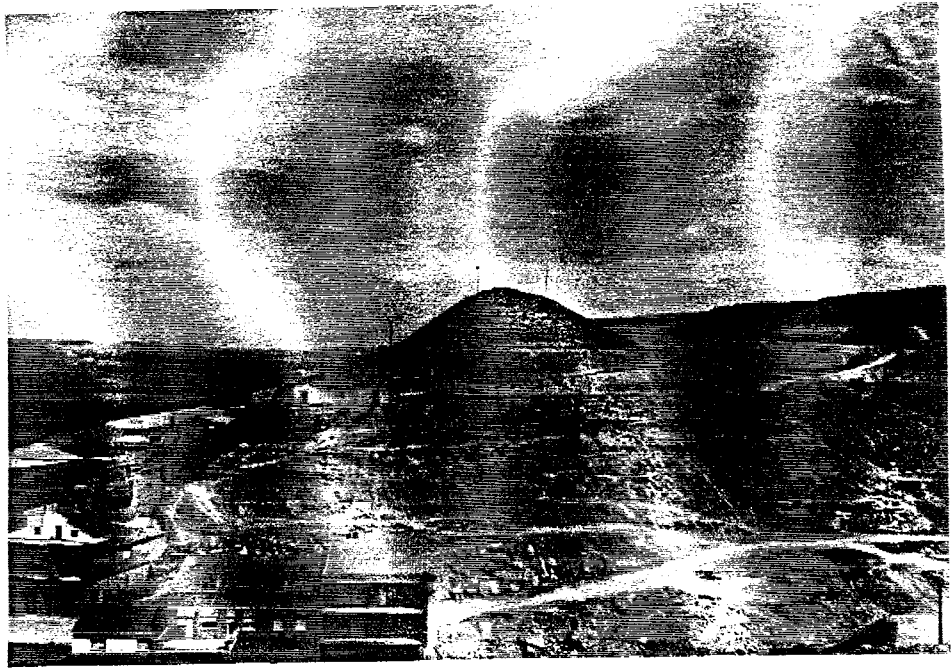

FOTOGRAFIA 25

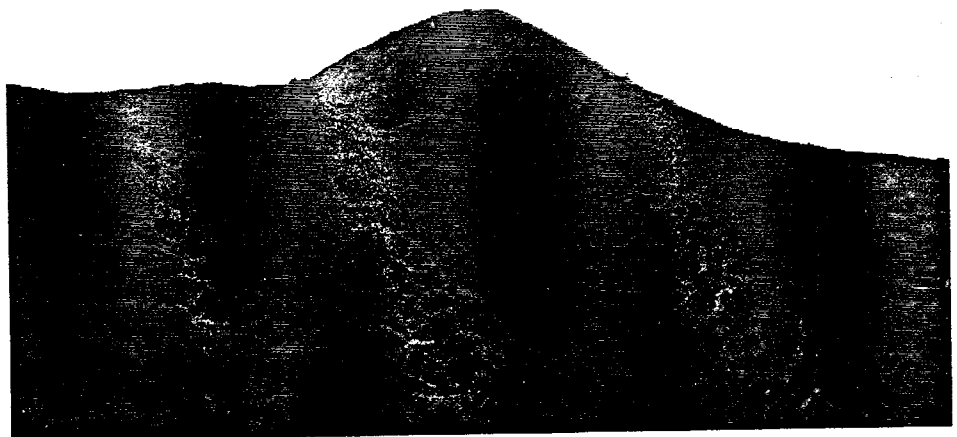

FOTOGRAFIA 26

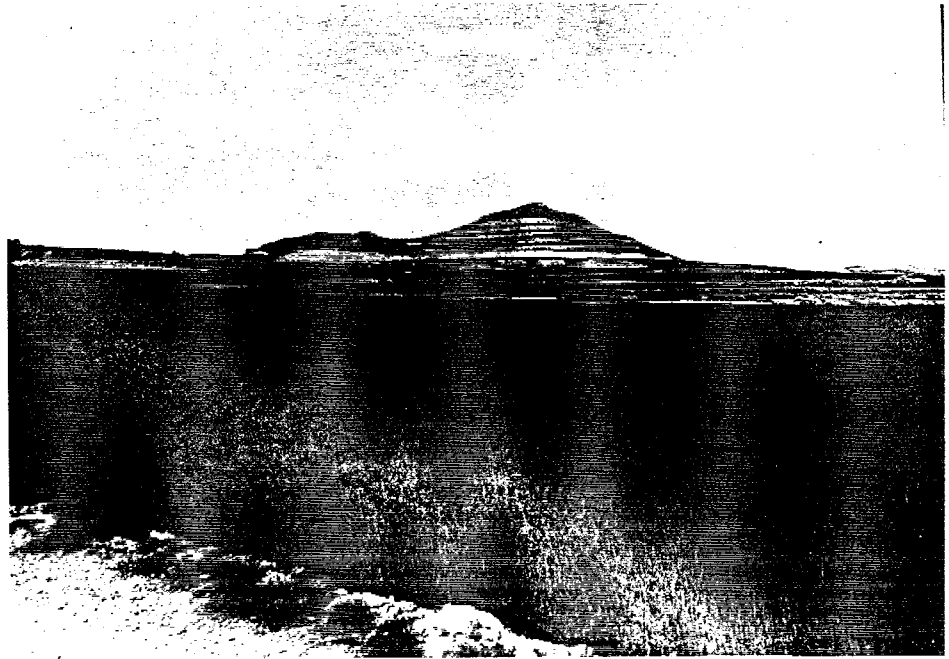

FOTOGRAFIA 27

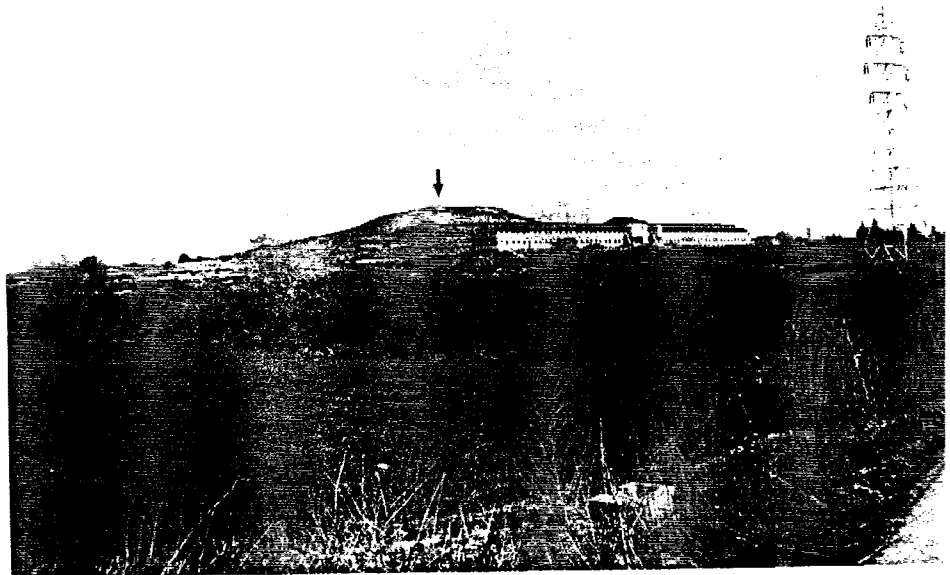

FOTOGRAFIA 28



FOTOGRAFIA 29



FOTOGRAFIA 30

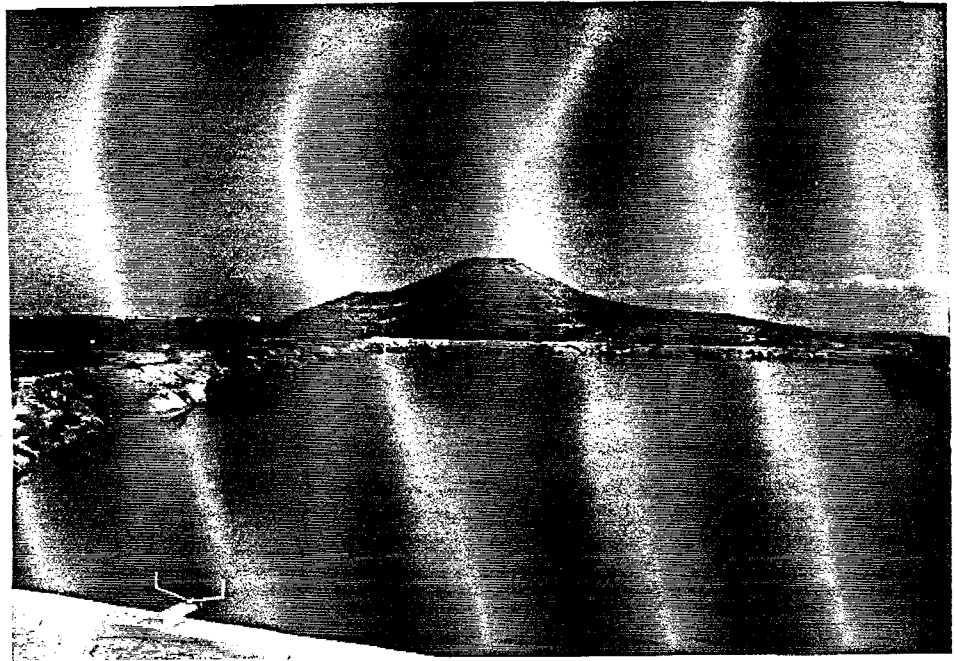

FOTOGRAFIA 31



FOTOGRAFIA 32

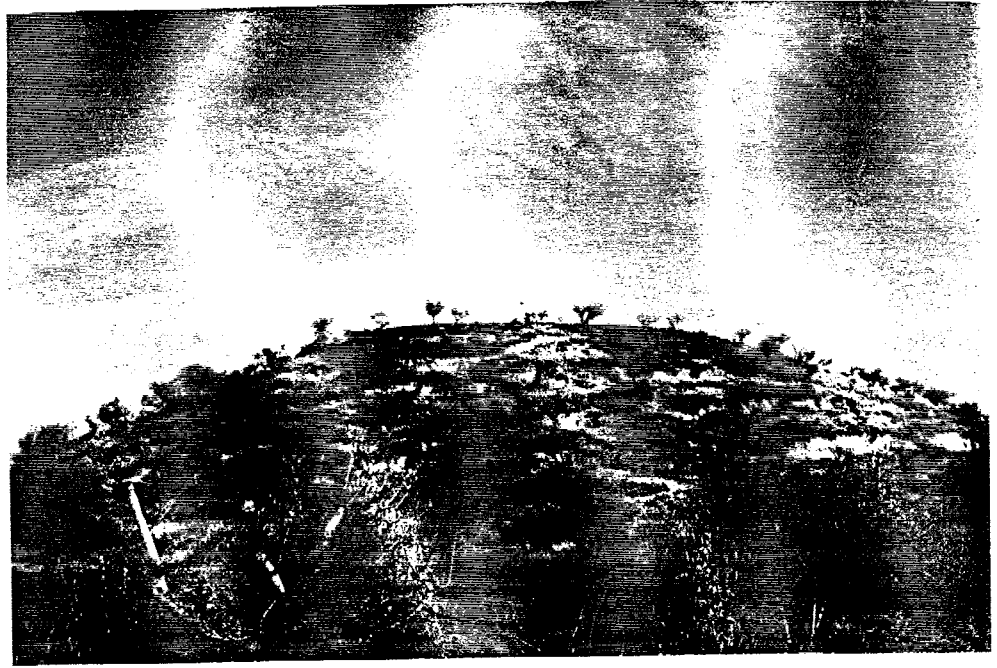

FOTOGRAFIA 33

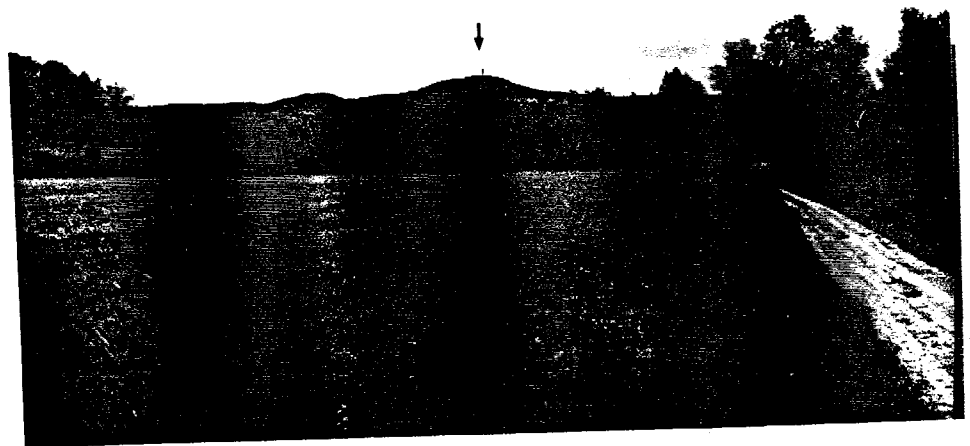

FOTOGRAFIA 34



FOTOGRAFIA 35



FOTOGRAFIA 36



FOTOGRAFIA 37

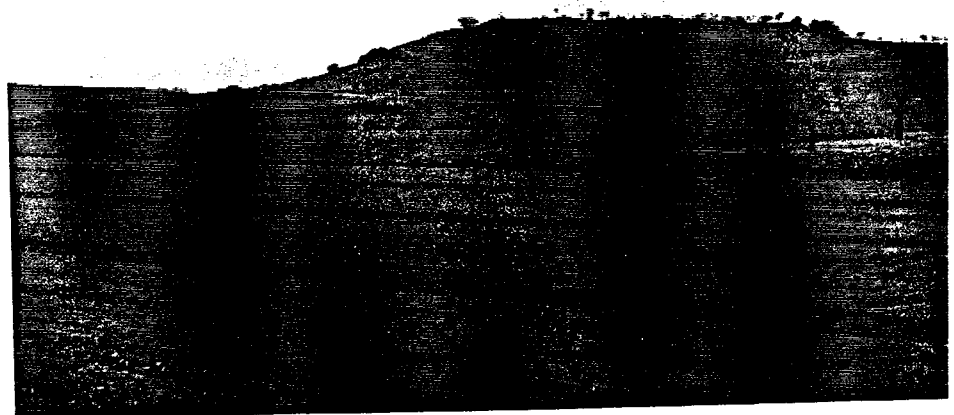

FOTOGRAFIA 38



FOTOGRAFIA 39

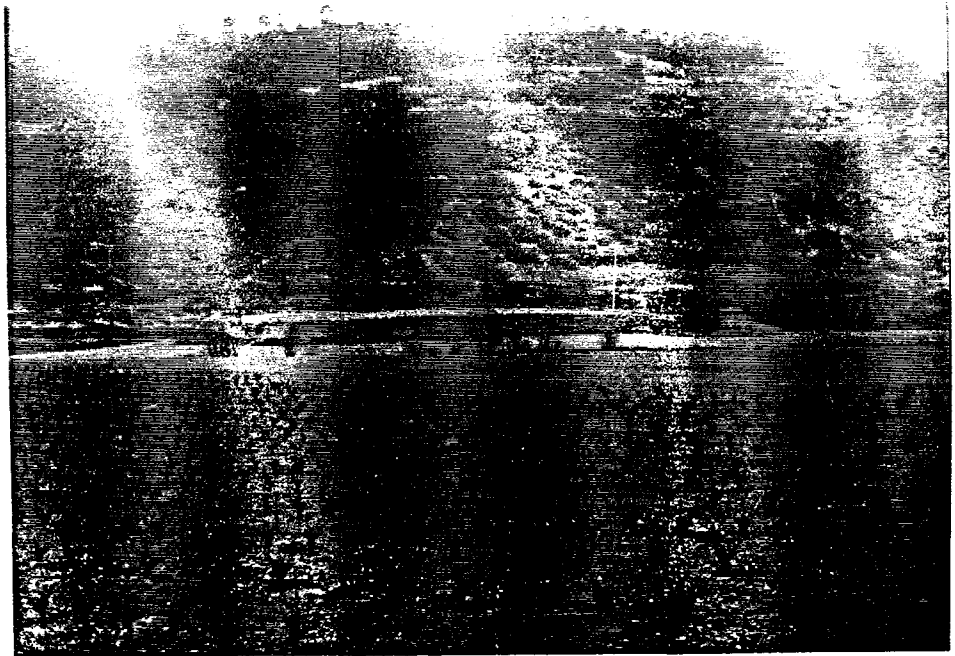

FOTOGRAFIA 40

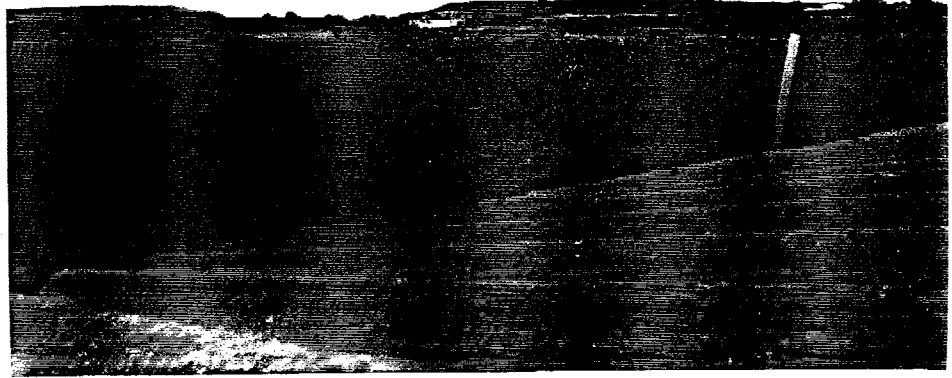

FOTOGRAFIA 41



FOTOGRAFIA 42



FOTOGRAFIA 43



FOTOGRAFIA 44



FOTOGRAFIA 45

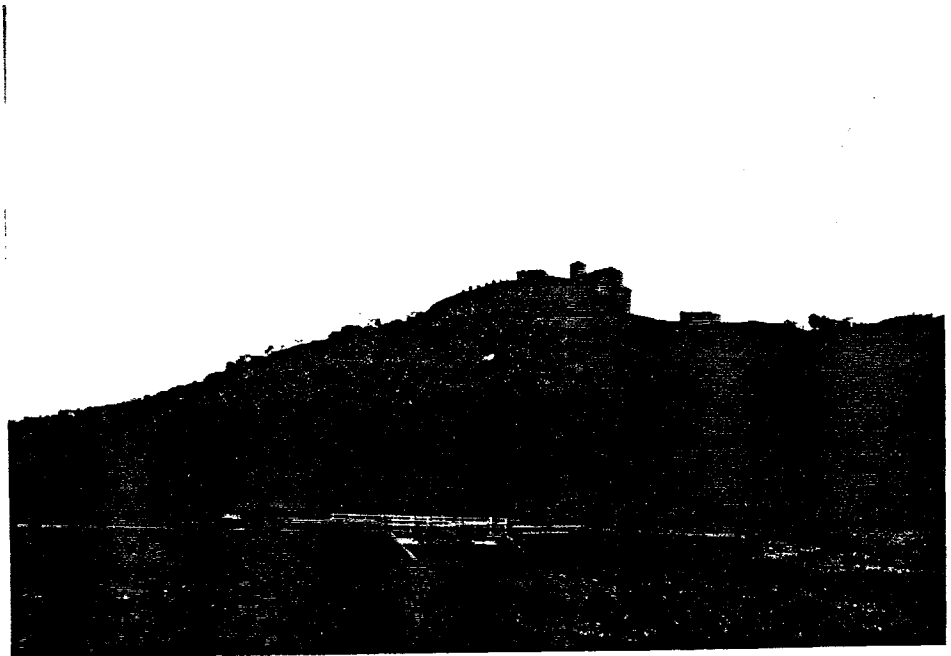

FOTOGRAFIA 46

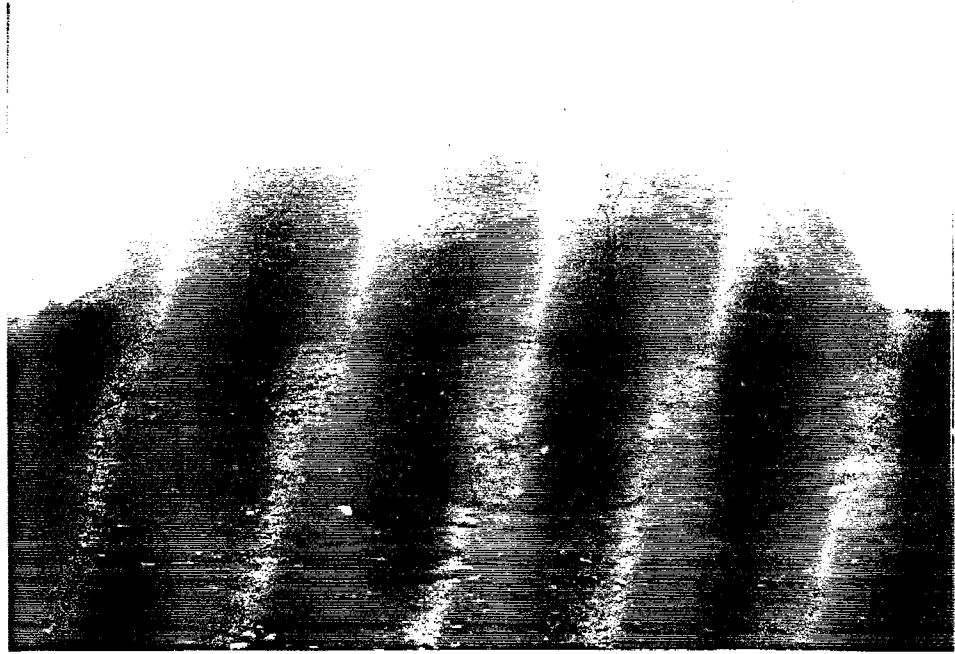

FOTOGRAFIA 47

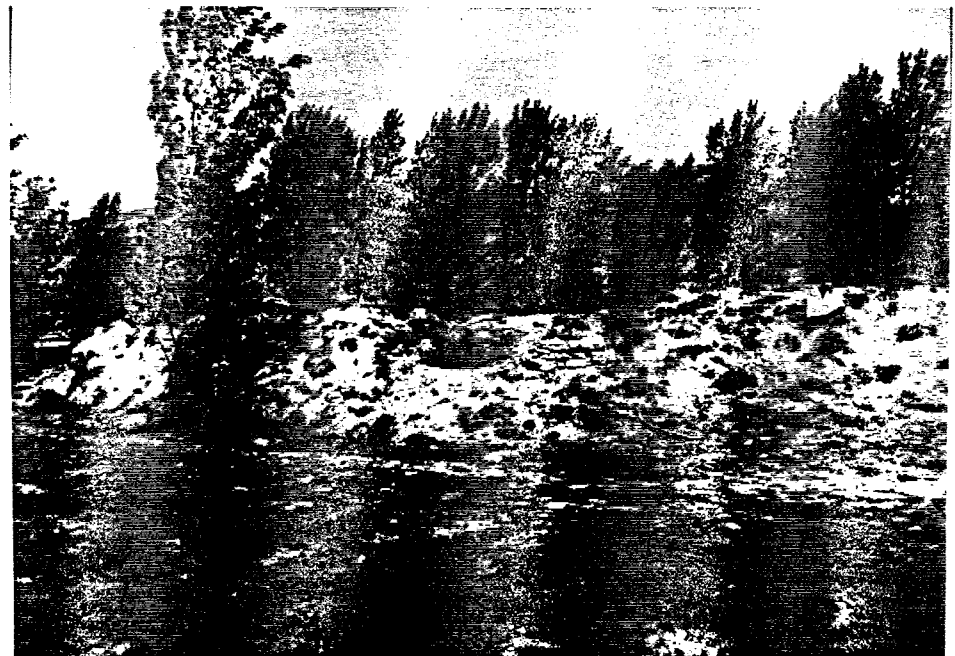

FOTOGRAFIA 48



FOTOGRAFIA 49



FOTOGRAFIA 50



FOTOGRAFIA 51

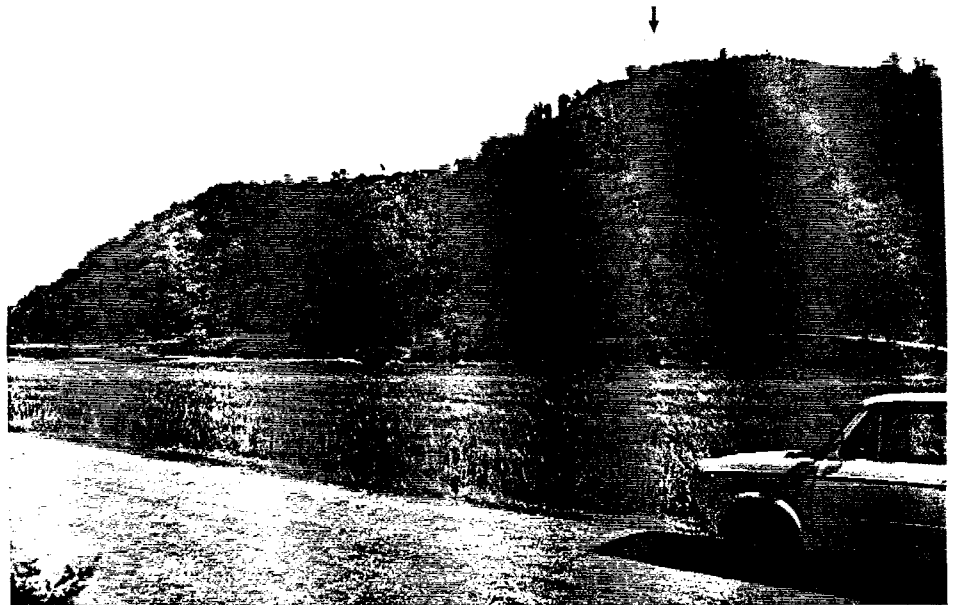

FOTOGRAFIA 52

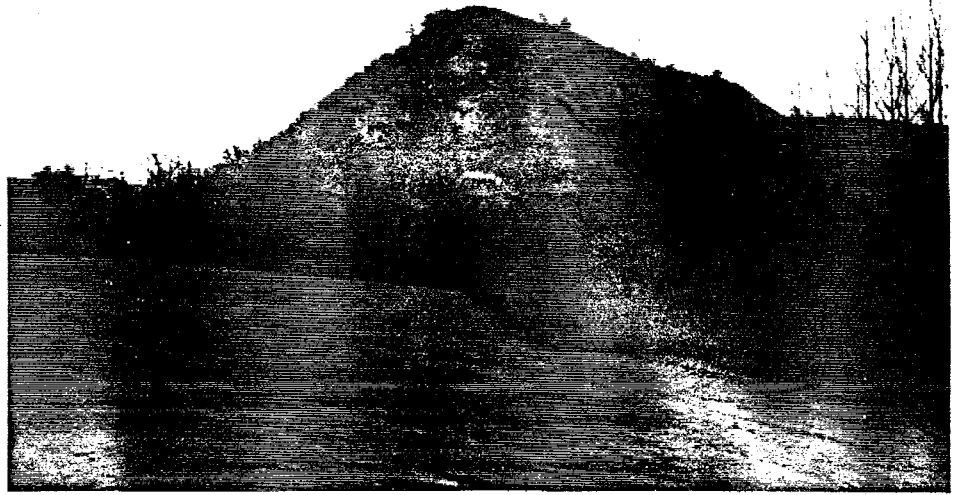

FOTOGRAFIA 53



FOTOGRAFIA 54

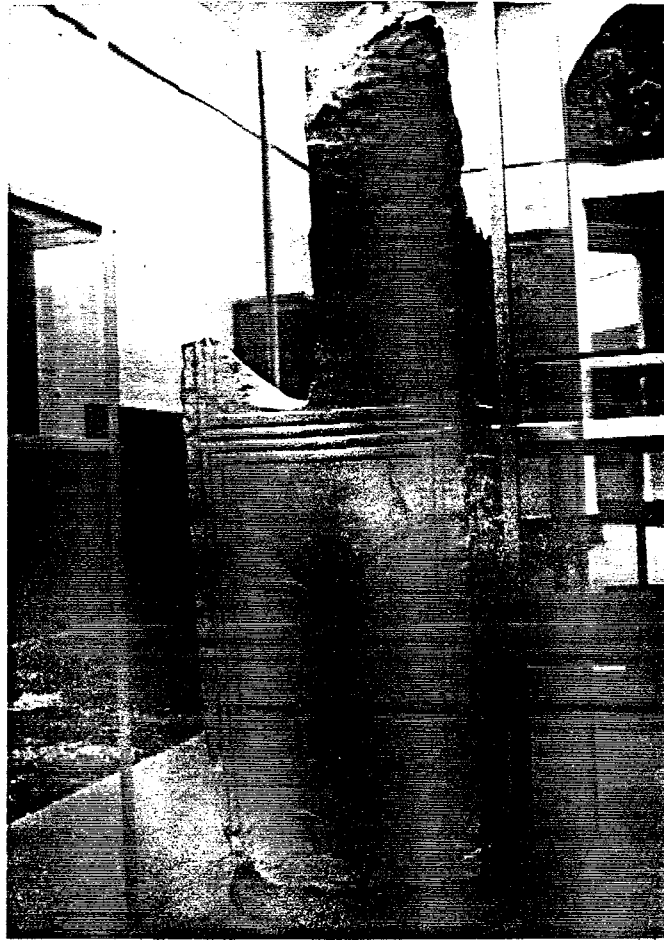

FOTOGRAFIA 55



FOTOGRAFIA 56



FOTOGRAFIA 57



FOTOGRAFIA 58



FOTOGRAFIA 59



FOTOGRAFIA 60