

**ADVERTIMENT.** L'accés als continguts d'aquesta tesi doctoral i la seva utilització ha de respectar els drets de la persona autora. Pot ser utilitzada per a consulta o estudi personal, així com en activitats o materials d'investigació i docència en els termes establerts a l'art. 32 del Text Refós de la Llei de Propietat Intel·lectual (RDL 1/1996). Per altres utilitzacions es requereix l'autorització prèvia i expressa de la persona autora. En qualsevol cas, en la utilització dels seus continguts caldrà indicar de forma clara el nom i cognoms de la persona autora i el títol de la tesi doctoral. No s'autoritza la seva reproducció o altres formes d'explotació efectuades amb finalitats de lucre ni la seva comunicació pública des d'un lloc aliè al servei TDX. Tampoc s'autoritza la presentació del seu contingut en una finestra o marc aliè a TDX (framing). Aquesta reserva de drets afecta tant als continguts de la tesi com als seus resums i índexs.

**ADVERTENCIA.** El acceso a los contenidos de esta tesis doctoral y su utilización debe respetar los derechos de la persona autora. Puede ser utilizada para consulta o estudio personal, así como en actividades o materiales de investigación y docencia en los términos establecidos en el art. 32 del Texto Refundido de la Ley de Propiedad Intelectual (RDL 1/1996). Para otros usos se requiere la autorización previa y expresa de la persona autora. En cualquier caso, en la utilización de sus contenidos se deberá indicar de forma clara el nombre y apellidos de la persona autora y el título de la tesis doctoral. No se autoriza su reproducción u otras formas de explotación efectuadas con fines lucrativos ni su comunicación pública desde un sitio ajeno al servicio TDR. Tampoco se autoriza la presentación de su contenido en una ventana o marco ajeno a TDR (framing). Esta reserva de derechos afecta tanto al contenido de la tesis como a sus resúmenes e índices.

**WARNING.** Access to the contents of this doctoral thesis and its use must respect the rights of the author. It can be used for reference or private study, as well as research and learning activities or materials in the terms established by the 32nd article of the Spanish Consolidated Copyright Act (RDL 1/1996). Express and previous authorization of the author is required for any other uses. In any case, when using its content, full name of the author and title of the thesis must be clearly indicated. Reproduction or other forms of for profit use or public communication from outside TDX service is not allowed. Presentation of its content in a window or frame external to TDX (framing) is not authorized either. These rights affect both the content of the thesis and its abstracts and indexes.



Departament de Teoria  
del Senyal i Comunicacions



UNIVERSITAT POLITÈCNICA DE CATALUNYA



# Resource Management in Multicarrier Based Cognitive Radio Systems

PhD Thesis Dissertation

By

Musbah M R Shaat

Submitted to the Universitat Politècnica de Catalunya (UPC)  
in partial fulfillment of the requirements for the degree of

DOCTOR OF PHILOSOPHY

Barcelona, January 2012

Supervised by: Dr. Faouzi Bader

Tutor: Prof. Miguel Ángel Lagunas Hernández

PhD program on Signal Theory and Communications



## THESIS EXAMINATION COMMITTEE

**Prof. Ana Isabel Perez Neira**

Universitat Politècnica de Catalunya (UPC)  
Barcelona-Spain

**Prof. Didier Le Ruyet**

Conservatoire National des Arts et Métiers (CNAM)  
Paris-France

**Prof. Santiago Zazo Bello**

Universidad Politécnica de Madrid (UPM)  
Madrid-Spain

**Prof. Mohamed-Slim Alouini**

King Abdullah University of Science and Technology (KAUST)  
Thuwal-Saudi Arabia

**Dr. Jocelyn Fiorina**

Supélec  
Paris-France



إلى والدي الكريمين ... طاعة وبراءاً وإمتناناً

إلى زوجتي الغالية ... مودة وتقديراً وعرفاناً

إلى مهجتي قلبي هدى وجنى ... حباً وحناناً



# Abstract

The ever-increasing growth of the wireless application and services affirms the importance of the effective usage of the limited radio spectrum. Existing spectrum management policies have led to significant spectrum under-utilization. Recent measurements showed that large range of the spectrum is sparsely used in both temporal and spatial manner. This conflict between the inefficient usage of the spectrum and the continuous evolution in the wireless communication calls upon the development of more flexible management policies. Cognitive radio (CR) with the dynamic spectrum access (DSA) is considered to be a key technology in making the best solution of this conflict by allowing a group of secondary users (SUs) to share the radio spectrum originally allocated to the primary user (PUs). The operation of CR should not negatively alter the performance of the PUs. Therefore, the interference control along with the highly dynamic nature of PUs activities open up new resource allocation problems in CR systems. The resource allocation algorithms should ensure an effective share of the temporarily available frequency bands and deliver the solutions in timely fashion to cope with quick changes in the network.

In this dissertation, the resource management problem in multicarrier based CR systems is considered. The dissertation focuses on three main issues: 1) design of efficient resource allocation algorithms to allocate subcarriers and powers between SUs such that no harmful interference is introduced to PUs, 2) compare the spectral efficiency of using different multicarrier schemes in the CR physical layer, specifically, orthogonal frequency division multiplexing (OFDM) and filter bank multicarrier (FBMC) schemes, 3) investigate the impact of the different constraints values on the overall performance of the CR system.

Three different scenarios are considered in this dissertation, namely downlink transmis-



sion, uplink transmission, and relayed transmission. For every scenario, the optimal solution is examined and efficient sub-optimal algorithms are proposed to reduce the computational burden of obtaining the optimal solution. The suboptimal algorithms are developed by separate the subcarrier and power allocation into two steps in downlink and uplink scenarios. In the relayed scenario, dual decomposition technique is used to obtain an asymptotically optimal solution, and a joint heuristic algorithm is proposed to find the suboptimal solution. Numerical simulations show that the proposed suboptimal algorithms achieve a near optimal performance and perform better than the existing algorithms designed for cognitive and non-cognitive systems. Eventually, the ability of FBMC to overcome the OFDM drawbacks and achieve more spectral efficiency is verified which recommends the consideration of FBMC in the future CR systems.

# Resumen

El crecimiento continuo de las aplicaciones y servicios en sistemas inalámbricos, indica la importancia y necesidad de una utilización eficaz del espectro radio. Las políticas actuales de gestión del espectro han conducido a una infrautilización del propio espectro radioeléctrico. Recientes mediciones en diferentes entornos han mostrado que gran parte del espectro queda poco utilizado en sus ambas vertientes, la temporal, y la espacial. El permanente conflicto entre el uso ineficiente del espectro y la evolución continua de los sistemas de comunicación inalámbrica, hace que sea urgente y necesario el desarrollo de esquemas de gestión del espectro más flexibles.

Se considera el acceso dinámico (DSA) al espectro en los sistemas cognitivos como una tecnología clave para resolver este conflicto al permitir que un grupo de usuarios secundarios (SUs) puedan compartir y acceder al espectro asignado inicialmente a uno o varios usuarios primarios (PUs). Las operaciones de comunicación llevadas a cabo por los sistemas radio cognitivos no deben en ningún caso alterar (interferir) los sistemas primarios. Por tanto, el control de la interferencia junto al gran dinamismo de los sistemas primarios implica nuevos retos en el control y asignación de los recursos radio en los sistemas de comunicación CR. Los algoritmos de gestión y asignación de recursos (Radio Resource Management-RRM) deben garantizar una participación efectiva de las bandas con frecuencias disponibles temporalmente, y ofrecer en cada momento oportunas soluciones para hacer frente a los distintos cambios rápidos que influyen en la misma red.

En esta tesis doctoral, se analiza el problema de la gestión de los recursos radio en sistemas multiportadoras CR, proponiendo varias soluciones para su uso eficaz y coexistencia con los PUs. La tesis en sí, se centra en tres líneas principales: 1) el diseño de algoritmos eficientes

de gestión de recursos para la asignación de sub-portadoras y distribución de la potencia en sistemas secundarios, evitando así cualquier interferencia que pueda ser perjudicial para el funcionamiento normal de los usuarios de la red primaria, 2) analizar y comparar la eficiencia espectral alcanzada a la hora de utilizar diferentes esquemas de transmisión multiportadora en la capa física del sistema CR, específicamente en sistemas basados en OFDM y los basados en banco de filtros multiportadoras (Filter bank Multicarrier-FBMC), 3) investigar el impacto de las diferentes limitaciones en el rendimiento total del sistema de CR.

Los escenarios considerados en esta tesis son tres, es decir; modo de transmisión descendente (downlink), modo de transmisión ascendente (uplink), y el modo de transmisión "Relay". En cada escenario, la solución óptima es examinada y comparada con algoritmos sub-óptimos que tienen como objetivo principal reducir la carga computacional. Los algoritmos sub-óptimos son llevados a cabo en dos fases mediante la separación del propio proceso de distribución de subportadoras y la asignación de la potencia en los modos de comunicación descendente (downlink), y ascendente (uplink). Para los entornos de tipo "Relay", se ha utilizado la técnica de doble descomposición (dual decomposition) para obtener una solución asintóticamente óptima. Además, se ha desarrollado un algoritmo heurístico para poder obtener la solución óptima con un reducido coste computacional.

Los resultados obtenidos mediante simulaciones numéricas muestran que los algoritmos sub-óptimos desarrollados logran acercarse a la solución óptima en cada uno de los entornos analizados, logrando así un mayor rendimiento que los ya existentes y utilizados tanto en entornos cognitivos como no-cognitivos. Se puede comprobar en varios resultados obtenidos en la tesis la superioridad del esquema multiportadora FBMC sobre los sistemas basados en OFDM para los entornos cognitivos, causando una menor interferencia que el OFDM en los sistemas primarios, y logrando una mayor eficiencia espectral. Finalmente, en base a lo analizado en esta tesis, podemos recomendar al esquema multiportadora FBMC como una idónea y potente forma de comunicación para las futuras redes cognitivas.

# Acknowledgements

During the writing of this thesis, I was looking forward to the moment when I write the last written part of the thesis; the "acknowledgement". Now, I realize that I was waiting for uneasy and important task. Having my name on the cover page of this thesis doesn't mean that it is a product of effort of single person. It's time to show my gratitude to many great people who have contributed to this thesis and made it possible.

Firstly, I am grateful to CTTC for their financial support for my doctoral studies. I have greatly enjoyed the research environment in CTTC.

An enormous debt of gratitude is owed to my supervisor, Dr. Faouzi Bader, for all kind of advice and support he gave to me throughout this work. I am grateful to his valuable and constructive criticism, comments and suggestions to keep me focused and on the track. With every passing day, I realize how lucky I am to work with such a pleasant and positive supervisor. Thanks Faouzi.

I am extremely grateful to my parents, brothers and my lovely sister, who missed me for being away from home for the past seven years. I am truly indebted to their support, encouragement, prayers and unconditional love. Without their help, I would not have managed to be in this stage in my life. Thank you very much.

I owe my loving thanks to my great wife Sima and to my daughters Huda and Jana. Thank you for being a wonderful family and going through the difficulties of having a student husband and father.

I want to thank all the people in CTTC. Special thanks go to my current and former (room 109) colleagues, Alessandro, Ana Maria, Angelos, Mr. Giuseppe, Jaime, Javi, Laia, Maria, Miguel Ángel and Pol. Believe me when I say that you made my daily life much easier inside

these four walls. I would also like to thank all secretaries and administrative staff of CTTC. I should not forget to thank Aurora Anguita for her appreciated help to me.

Finally, I am also appreciated to dedicate a few words to my best friends, Amer Ashour and Mohammed Mushtaha, who have been literally always there to remember me what really good friends are for. I want to express my thankfulness to my friend from Gaza, Abdullah and close friends here in Barcelona, Amr Radwan and Islam Hassoneh. I am also thankful for Dr. Omar Surkhi for his help when I moved to Barcelona.

Thank you all so much. Part of this PhD is also yours.

*Musbah Shaat*  
Barcelona, Spain  
January, 2012

# List of Publications

## Publication directly related with the dissertation:

### Journals

- [J1] **M. Shaat** and F. Bader, "Asymptotically optimal resource allocation in OFDM-based cognitive networks with multiple relays," accepted in *IEEE Transactions on Wireless Communications*.
- [J2] **M. Shaat** and F. Bader, "Efficient resource allocation algorithm for uplink in multicarrier-based cognitive radio networks with fairness consideration," in *IET Communications*, Nov 2011. Volume 5, Issue 16. pp. 2328-2338.
- [J3] **M. Shaat** and F. Bader, "Computationally efficient power allocation algorithm in multicarrier-based cognitive radio networks: OFDM and FBMC systems," *EURASIP Journal on Advances in Signal Processing*, vol. 2010, Article ID 528378, 13 pages ,2010.

### Book Chapters

- [B1] **M. Shaat** and F. Bader, "Channel Assignment and Power Allocation Algorithms in Multicarrier Based Cognitive Radio Environment," *Book Title: Cognitive Communications: Distributed Artificial Intelligence (DAI), Regulatory Policy & Economics, Implementation* .Eds. David Grace and Honggang Zhang, to be published in 2012 by Wiley. ISBN: 978-11-199-5150-6.
- [B2] **M. Shaat** and F. Bader, "Power allocation with interference constraint in multicarrier based cognitive radio systems," *Book Title: Multi-Carrier Systems and Solutions. Chapter 4: Adaptive Transmission* .Eds. Plass, S.; Dammann, A.; Kaiser, S.; Fazel, K. Springer 2009. ISBN: 978-90-481-2529-6 (HB). Netherlands.

## International Conferences

- [C1] **M. Shaat** and F. Bader, "Joint Resource Optimization in Decode and Forward Multi-relay Cognitive Network With Direct Link," *Accepted in IEEE Wireless Communications and Networking Conference, (WCNC'12)*, Paris-France.
- [C2] **M. Shaat** and F. Bader, "Asymptotically Optimal Subcarrier Matching and Power Allocation for Cognitive Relays With Power and Interference Constraints," *Accepted in IEEE Wireless Communications and Networking Conference, (WCNC'12)*, Paris-France.
- [C3] **M. Shaat** and F. Bader, "Joint subcarrier pairing and power allocation for DF-Relayed OFDM cognitive systems," to appear in *IEEE Global Telecommunications Conference (GLOBECOM'11)*, Houston-USA, Dec. 2011.
- [C4] **M. Shaat** and F. Bader, "Optimal resource allocation in multi-Relay cognitive networks using dual decomposition," in *ICT-ACROPOLIS Network of Excellence Workshop on "Cognitive Radio and Networking: Challenges and Solutions Ahead" jointly located with IEEE 22nd International Symposium on Personal, Indoor and Mobile Radio Communications (PIMRC'11)*, Toronto-Canada, Sept. 2011, pp. 2335–2339.
- [C5] **M. Shaat** and F. Bader, "Optimal and suboptimal resource allocation for two-Hop OFDM-Based multi-Relay cognitive networks," in *IEEE 22nd International Symposium on Personal, Indoor and Mobile Radio Communications (PIMRC'11)*, Toronto-Canada, Sept. 2011, pp. 477–481.
- [C6] **M. Shaat** and F. Bader, "Optimal power allocation algorithm for OFDM-Based decode-and-Forward dual- Hop cognitive systems," in *IEEE 73rd Vehicular Technology Conference (VTC Spring)*, Budapest-Hungary, May 2011, pp. 1–5.
- [C7] **M. Shaat** and F. Bader, "Efficient uplink subcarrier and power allocation algorithm in cognitive radio networks," in *7th International Symposium on Wireless Communication Systems (ISWCS'10)*, York-UK, Sept. 2010, pp. 223–227
- [C8] **M. Shaat** and F. Bader, "Fair and efficient resource allocation algorithm for uplink multicarrier based cognitive networks," in *IEEE 21st International Symposium on Personal Indoor and Mobile Radio Communications (PIMRC'10)*, Istanbul-Turkey, Sept. 2010, pp. 1212 –1217.
- [C9] **M. Shaat** and F. Bader, "An uplink resource allocation algorithm for OFDM and FBMC based cognitive radio systems," in *Proceedings of the Fifth International Conference on Cognitive Radio Oriented Wireless Networks Communications (CROWNCOM'10)*, Cannes-France, June 2010, pp. 1–6.

- [C10] **M. Shaat** and F. Bader, "A two-step resource allocation algorithm in multicarrier based cognitive radio systems," in *IEEE Wireless Communications and Networking Conference (WCNC'10)*, Sydney-Australia, April 2010, pp. 1–6.
- [C11] **M. Shaat** and F. Bader, "Downlink resource allocation algorithm in OFDM/FBMC cognitive radio networks," in *the 3rd Mosharaka International Conference on Communications, Signals and Coding (MICCSC'09)*, Amman-Jordan, Nov. 2009.
- [C12] **M. Shaat** and F. Bader, "Low complexity power loading scheme in cognitive radio networks: FBMC capability," in *IEEE 20th International Symposium on Personal, Indoor and Mobile Radio Communications (PIMRC'09)*, Tokyo-Japan, Sept. 2009.
- [C13] **M. Shaat** and F. Bader, "Power allocation and throughput comparison in OFDM and FBMC based cognitive radio," in *Proceeding of 22nd Meeting of the Wireless World Research Forum (WWRF'09)*, Paris-France, May 2009.

#### **Workshop Presentations:**

- [W1] **M. Shaat**, F. Bader, "Suboptimal Resource Allocation for Two-Hop OFDM Based Multi-Relay in Cognitive Networks", *2nd International Workshop COST Action IC 0902 on Cognitive Radio and Networking for Cooperative Coexistence of Heterogeneous Wireless Network*, Castelldefels-Spain, Oct. 2011.
- [W2] **M. Shaat**, F. Bader, "Centralized Power Loading Schemes in FBMC Based Cognitive Radio Networks" *1st International PHYDYAS Workshop jointly located with the 10th IEEE International Workshop on Signal Processing Advances in Wireless Communications (SPAWC'09)*, Perugia-Italy, June 2009.

#### **Publication indirectly related with the dissertation:**

- [J4] F. Bader, **M. Shaat**, "Pilot Pattern Design for PUSC MIMO WiMAX-like Filter Banks Multicarrier System", *IARIA International Journal On Advances in Telecommunications*, 2011, vol 4, no 1&2 January to June 2011.
- [C13] H. Soury, F. Bader, **M. Shaat** and M.-S. Alouini, "Optimal Power Allocation Algorithm for OFDM-Based Cognitive Adaptive Relaying Networks", *to be Submitted to the seventh International Conference on Cognitive Radio Oriented Wireless Networks Communications (CROWNCOM'12)*, Stockholm-Sweden.



[C14] F. Bader, **M. Shaat**, "Pilot Pattern Adaptation and Channel Estimation in MIMO WIMAX-Like FBMC System", in *Proc. of Sixth International Conference on Wireless and Mobile Communications (ICWMC'2010)*. September 20-25, 2010 - Valencia, Spain.

### **Project Technical Reports:**

- [T1] **M. Shaat** and F. Bader, "Subcarrier Selection and Power Loading for Multicarrier Based Cognitive Networks Under Interference and Fairness Constraints", *Draft report for COST IC0902/WG1 - Cognitive Radio and Networking for Cooperative Coexistence of Heterogeneous Wireless Networks*, Sept. 2011.
- [T2] **M. Shaat** and F. Bader, "Subcarrier/Power Loading Schemes in OFDM/FBMC Based Cognitive Radio Networks", *technical contribution report in the deliverable D8.3 " Application of the FBMC physical layer in a cognitive radio scenario"*, European ICT-211887 FP7 PHYDYAS project, July 2010.
- [T3] **M. Shaat** and F. Bader, "Interference-Aware Power Allocation Algorithms in Multicarrier Based Cognitive Radio Networks: OFDM and FBMC systems", *technical contribution report in the deliverable D8.1 " Application of the FBMC physical layer in a cognitive radio scenario"*, European ICT-211887 FP7 PHYDYAS project, June 2009.

# Contents

<b>1</b>	<b>Introduction</b>	<b>1</b>
1.1	Motivation and Scope . . . . .	1
1.2	Organization of the Dissertation . . . . .	4
	Bibliography . . . . .	8
<b>2</b>	<b>Background</b>	<b>11</b>
2.1	Cognitive Radio Overview . . . . .	12
2.1.1	Cognitive Radio Definition and Characteristics . . . . .	12
2.1.2	Cognitive Radio Functions . . . . .	14
2.1.3	Dynamic Spectrum Access . . . . .	17
2.1.4	Interference Temperature Model . . . . .	20
2.1.5	Cognitive Radio Standardization . . . . .	22
2.2	Multicarrier Systems Overview . . . . .	24
2.2.1	Orthogonal Frequency Division Multiplexing (OFDM) system . . . . .	24
2.2.2	Filter Bank Multicarrier (FBMC) system . . . . .	28
2.2.3	Structure and Implementation of OQAM-OFDM . . . . .	32
2.2.4	Non Orthogonal Frequency Division Multiplexing (NOFDM) Systems . . . . .	37
2.2.5	Summary of OFDM and FBMC Differences . . . . .	40
2.3	Resource Management in Multicarrier Systems . . . . .	41
2.3.1	Resource Allocation in Single User Multicarrier systems . . . . .	42

2.3.2	Resource Allocation in Multi-user Multicarrier systems . . . . .	43
2.4	Constrained Optimization . . . . .	45
2.4.1	Lagrangian Method and Optimality Conditions . . . . .	47
2.4.2	Interior Point Method . . . . .	48
2.4.3	Subgradient Method . . . . .	49
2.4.4	Duality . . . . .	50
	Bibliography . . . . .	53
<b>3</b>	<b>Resource Allocation in Downlink Multicarrier Based Cognitive Radio Systems</b>	<b>69</b>
3.1	Introduction . . . . .	69
3.2	System Model . . . . .	73
3.3	Problem Formulation . . . . .	75
3.4	Proposed Low Complexity Algorithm . . . . .	78
3.5	Simulation Results . . . . .	85
3.5.1	Case 1: Two Active PU Bands . . . . .	86
3.5.2	Case 2: Single Active PU Band . . . . .	91
3.6	Chapter Summary and Conclusions . . . . .	93
3.A	Appendix . . . . .	95
3.A.1	Derivation of the Optimal Power Allocation Given By Equation (3.12) . . . . .	95
	Bibliography . . . . .	97
<b>4</b>	<b>Resource Allocation in Uplink Multicarrier Based Cognitive Radio Systems</b>	<b>103</b>
4.1	Introduction . . . . .	104
4.2	System Model and Problem Formulation . . . . .	106
4.3	Proposed Subcarrier and Power Allocation Algorithms (Single PU Case) . . . . .	110
4.3.1	Proposed Subcarrier Allocation Algorithm with Fairness Consideration . . . . .	111
4.3.2	Proposed Power Allocation Algorithm . . . . .	114
4.4	Generalization of the Proposed Algorithms (Multiple PUs Case) . . . . .	117
4.5	Computational Complexity Analysis . . . . .	121

4.6	Simulation Results . . . . .	122
4.6.1	Case 1: OFDM with Small Number of SUs and Subcarriers . . . . .	123
4.6.2	Case 2: OFDM with High Number of SUs and Subcarriers . . . . .	124
4.6.3	Case 3: OFDM and FBMC with Low/High Number of SUs and Subcarriers . . . . .	129
4.7	Chapter Summary and Conclusions . . . . .	131
4.A	Appendix . . . . .	133
4.A.1	Derivation of the Optimal Power Allocation Given By Equations (4.15) and (4.23) . . . . .	133
	Bibliography . . . . .	135
<b>5</b>	<b>Resource Allocation in Multicarrier Based Relayed Cognitive Radio Systems</b>	<b>141</b>
5.1	Introduction . . . . .	141
5.2	System Model . . . . .	145
5.3	Problem Formulation . . . . .	147
5.4	Asymptotically Optimal Solution Using Dual Decomposition Technique . . . .	150
5.5	Suboptimal Algorithm and Complexity Comparison . . . . .	154
5.6	Simulation Results . . . . .	157
5.6.1	Case 1: Multi-relay CR System with Direct Link Transmission Ability .	158
5.6.2	Case 2: Single-relay CR System with Blocked Direct Link Transmission	163
5.7	Chapter Summary and Conclusions . . . . .	166
5.A	Appendix . . . . .	168
5.A.1	Power Allocation Under the Interference Constraint Only with Known Subcarrier Pairs . . . . .	168
	Bibliography . . . . .	171
<b>6</b>	<b>General Conclusions and Future Work</b>	<b>177</b>
6.1	Conclusions . . . . .	178
6.2	Future Work . . . . .	181
	Bibliography . . . . .	185

# List of Figures

2.1	Spectrum utilization. . . . .	12
2.2	Spectrum holes (or spectrum opportunities). . . . .	14
2.3	A taxonomy of spectrum sensing. . . . .	17
2.4	A taxonomy of dynamic spectrum access. . . . .	18
2.5	Overlay and underlay spectrum access techniques. . . . .	19
2.6	Interference temperature model. . . . .	21
2.7	OFDM system block diagram. . . . .	25
2.8	CP insertion in the OFDM symbol. . . . .	25
2.9	Frequency representation of three subcarriers in OFDM signal. . . . .	26
2.10	Frequency response of OFDM and RC windowing OFDM with roll-off parameter $\beta = 0.5$ and $\beta = 1$ . . . . .	27
2.11	Frequency response of OFDM and FBMC filters . . . . .	29
2.12	General filter bank structure. . . . .	30
2.13	AFB and SFB different arrangements. . . . .	30
2.14	OQAM-OFDM system's transmitter and receiver. . . . .	33
2.15	Symbols distribution in time/subcarrier plan for OQAM-OFDM and OFDM systems. . . . .	34
2.16	PHYDYAS filter impulse response. . . . .	37
2.17	OFDM and PHYDYAS filters frequency responses. . . . .	38
2.18	Time-Frequency representation of NOFDM transmission frame. . . . .	39

2.19	Description of the water-filling principle. . . . .	42
2.20	Description of the constant water-filling principle. . . . .	43
2.21	Description of the mercury water-filling principle. . . . .	43
3.1	Cognitive Radio Network. . . . .	73
3.2	Frequency distribution of the active and non-active primary bands. . . . .	74
3.3	Flowchart of the proposed subcarrier and power allocation algorithm. . . . .	81
3.4	Cap-Limited waterfilling graphical example. . . . .	82
3.5	Example of the SUs allocated power using proposed <i>PI-Algorithm</i> . . . . .	83
3.6	Frequency distribution with two active PU bands. . . . .	87
3.7	Achieved capacity vs allowed interference threshold for OFDM and FBMC based CR systems - Two active PU bands. . . . .	87
3.8	Total interference introduced to the $PU_1$ vs interference threshold. . . . .	88
3.9	Total interference introduced to the $PU_2$ vs interference threshold. . . . .	88
3.10	Achieved CR vs allowed interference threshold (low) for OFDM and FBMC based CR systems - Two active bands. . . . .	89
3.11	Achieved capacity vs allowed interference threshold with and without trans- mitting over active bands- Two active PU bands. . . . .	90
3.12	Achieved capacity vs allowed interference threshold (low) with and without transmitting over active bands - Two active PU bands. . . . .	91
3.13	Frequency distribution with one active PU band. . . . .	92
3.14	Achieved capacity vs allowed interference threshold for OFDM and FBMC based CR systems - One active PU band. . . . .	92
3.15	Achieved capacity vs allowed interference threshold (low) for OFDM and FBMC based CR systems - One active PU band. . . . .	93
4.1	Uplink Cognitive Radio Network. . . . .	107
4.2	Frequency distribution of active and non-active primary bands. . . . .	107
4.3	Example of the SUs allocated power using proposed power allocation algorithm. . . . .	117
4.4	Flowchart of the proposed power allocation algorithm. . . . .	119

4.5	Three SUs Achieved capacity vs interference threshold when $N = 8$ subcarriers, $\overline{P_m} = 1$ mWatt, $B^1 = B^2 = 1.25$ MHz, and $R_{min} = 4$ Mbits/sec. . . . .	123
4.6	Outage probability vs allowed interference thresholds when $N = 8$ subcarriers, $\overline{P_m} = 1$ mWatt, $B^1 = B^2 = 1.25$ MHz, and $R_{min} = 4$ Mbits/sec. . . . .	124
4.7	Achieved capacity vs allowed interference thresholds when $N = 128$ subcarriers, $M = 8$ SUs, $\overline{P_m} = 1$ mWatt, $B^1 = B^2 = 10$ MHz, and $R_{min} = 20$ Mbits/sec. . . . .	125
4.8	Outage probability vs allowed interference thresholds when $N = 128$ subcarriers, $M = 8$ SUs, $\overline{P_m} = 1$ mWatt, $B^1 = B^2 = 10$ MHz, and $R_{min} = 20$ Mbits/sec. . . . .	126
4.9	Achieved capacity vs No. of SUs when $N = 128$ subcarriers, $\overline{P_m} = 1$ mWatt, $B^1 = B^2 = 10$ MHz, and $R_{min} = 20$ Mbits/sec. . . . .	127
4.10	Achieved capacity vs per-user power $\overline{P_m}$ when $N = 128$ subcarriers, $M = 8$ SUs, $B^1 = B^2 = 10$ MHz, and $R_{min} = 20$ Mbits/sec. . . . .	128
4.11	Instantaneous rates over time when $N = 128$ subcarriers, $M = 8$ SUs, $\overline{P_m} = 1$ mWatt, $B^1 = B^2 = 10$ MHz, $I_{th}^1 = I_{th}^2 = -20$ dBm and $R_{min} = 20$ Mbits/sec (80 bits per OFDM symbol). . . . .	129
4.12	Achieved capacity vs allowed interference threshold when $N = 8$ subcarriers, $M = 2$ SUs, $\overline{P_m} = 1$ mWatt and $B = 2.5$ MHz. . . . .	130
4.13	Achieved capacity vs allowed interference threshold when $N = 64$ subcarriers, $M = 10$ SUs, $\overline{P_m} = 1$ mWatt and $B = 10$ MHz. . . . .	130
5.1	Cooperative relay cognitive radio network. . . . .	146
5.2	Achieved capacity vs allowed interference threshold. The solid lines when $P_S = P_R = 0$ dBm while the dashed ones when $P_S = P_R = 20$ dBm. . . . .	159
5.3	Achieved capacity vs allowed interference thresholds and power budget constraints. . . . .	159
5.4	Achieved capacity vs the interference threshold. The solid lines when with $P_S = P_{R_m} = 0$ . dBm while the dashed ones when with $P_S = P_{R_m} = 20$ . dBm. . . . .	160
5.5	Achieved capacity vs available power budget with $P_S = P_{R_m}$ . The solid lines when $I_{th} = -30$ dBm while the dashed ones when $I_{th} = -10$ dBm. . . . .	162

5.6	Achieved capacity vs the interference threshold with $P_S = P_{R_m} = 0$ dBm. OFDM based system is plotted by the solid lines while the dashed ones represent the FBMC based systems . . . . .	162
5.7	Achieved capacity vs available power budget with $P_S = P_{R_m}$ when $I_{th} = -30$ dBm. OFDM based system is plotted by the solid lines while the dashed ones represent the FBMC based systems. . . . .	163
5.8	Achieved capacity vs the interference threshold in single-relay CR system. The solid lines when with $P_S = P_{R_m} = 0$ . dBm while the dashed ones when with $P_S = P_{R_m} = 20$ . dBm. . . . .	164
5.9	Achieved capacity vs available power budget with $P_S = P_{R_m}$ in single-relay CR system. The solid lines when $I_{th} = -30$ dBm while the dashed ones when $I_{th} = -10$ dBm. . . . .	165
5.10	Achieved capacity vs the interference threshold in single-relay CR system with interference constraint only. . . . .	165



# List of Tables

2.1	Comparison of the primary transmitter detection techniques. . . . .	16
3.1	Computational complexity comparison - downlink scenario . . . . .	85
4.1	Computational complexity comparison - uplink scenario . . . . .	122
5.1	Computational complexity comparison - relayed scenario . . . . .	155

# List of acronyms

<b>AWGN</b>	Additive White Gaussian Noise
<b>AF</b>	Amplify and Forward
<b>AFB</b>	Analysis Filter Bank
<b>BS</b>	Base Station
<b>CDMA</b>	Code Division Multiple Access
<b>CBS</b>	Cognitive Base Station
<b>CR</b>	Cognitive Radio
<b>CMT</b>	Cosine-Modulated multiTune
<b>CPE</b>	Customer Premises Equipment
<b>CP</b>	Cyclic Prefix
<b>DF</b>	Decode-and-Forward
<b>DFT</b>	Discrete Fourier Transform
<b>DRiVE</b>	Dynamic Radio for IP-Services in Vehicular Environments
<b>DSA</b>	Dynamic Spectrum Access
<b>ETSI</b>	European Telecommunications Standards Institute
<b>FFT</b>	Fast Fourier Transformation
<b>FCC</b>	Federal Communications Commission
<b>FBMC</b>	Filter Bank MultiCarrier
<b>FMT</b>	Filtered MultiTune
<b>GAP</b>	Generalized Assignment Problem
<b>GMC</b>	Generalized MultiCarrier
<b>ISM</b>	Industrial, Scientific and Medical

<b>ICI</b>	Inter Carrier Interference
<b>IEEE</b>	Institute of Electrical and Electronics Engineers
<b>ITU</b>	International Telecommunication Union
<b>ISI</b>	Inter-Symbol Interference
<b>IDFT</b>	Inverse Discrete Fourier Transform
<b>IFFT</b>	Inverse Fast Fourier Transformation
<b>IOTA</b>	Isotropic Orthogonal Transfer Algorithm
<b>KKT</b>	Karush-Kuhn-Tucker
<b>LSE</b>	Least Square Error
<b>LP</b>	Linear Programming
<b>LTE</b>	Long Term Evolution
<b>MM</b>	Margin Maximization
<b>MAC</b>	Medium Access Control
<b>MAI</b>	Multiple Access Interference
<b>MIMO</b>	Multiple Input Multiple Output
<b>MCKP</b>	Multiple-Choice Knapsack Problem
<b>MCS</b>	Multiple-Choice Sequence
<b>MT</b>	MultiTaper
<b>NPR</b>	Near Perfect Reconstruction
<b>NOFDM</b>	Non orthogonal Frequency Division Multiplexing
<b>NLP</b>	Non-Linear Programming
<b>OQAM-OFDM</b>	Offset Quadrature Amplitude Modulated-Orthogonal Frequency Division Multiplexing
<b>OFDM</b>	Orthogonal Frequency Division Multiplexing
<b>OFDMA</b>	Orthogonal Frequency-Division Multiple Access
<b>PAPR</b>	Peak-to-Average Power Ratio
<b>PHY</b>	PHYSical
<b>PHYDYAS</b>	PHYSical layer for DYnamic spectrum AccesSand cognitive radio
<b>PI-Algorithm</b>	Power Interference constrained Algorithm
<b>PLC</b>	Power Line Communication
<b>PSD</b>	Power Spectrum Density
<b>PR</b>	Prefect Reconstruction
<b>PU<sub>s</sub></b>	Primary Users

<b>PAM</b>	Pulse Amplitude Modulation
<b>QAM</b>	Quadrature Amplitude Modulation
<b>QoS</b>	Quality of Service
<b>RC</b>	Raised Cosine
<b>RM</b>	Rate Maximization
<b>SUs</b>	Secondary Users
<b>SINR</b>	Signal to Interference plus Noise Ratio
<b>SNR</b>	Signal to Noise Ratio
<b>SDR</b>	Soft-Defined Radio
<b>SFB</b>	Synthesis Filter Bank
<b>TF</b>	Time and Frequency
<b>UWB</b>	Ultra Wide Band
<b>U-NII</b>	Unlicensed National Information Infrastructure
<b>VSB</b>	Vestigial SideBand
<b>WRAN</b>	Wireless Regional Area Network
<b>WLAN</b>	wireless Local Access Network
<b>WiMAX</b>	Worldwide Interoperability for Microwave Access

# Notation

$x$	Scalar notation
$x^*$	Complex conjugate of $x$
$\mathbf{x}$	Vector notation
$\mathcal{X}$	Set notation
$\operatorname{Re}[x]$	Real part of $x$
$\operatorname{Im}[x]$	Imaginary part of $x$
$ x $	Absolute value of $x$
$ \mathcal{X} $	Cardinality of the set $\mathcal{X}$
$[x]^+$	Equivalent to $\max(0, x)$
$\lfloor x \rfloor$	Floor function
$\log(x)$	Natural logarithm of $x$
$\log_2(x)$	Logarithm in base 2 of $x$
$\langle \mathbf{x}, \mathbf{y} \rangle$	Inner product of $\mathbf{x}$ and $\mathbf{y}$
$\ \mathbf{x}\ $	Certain norm of vector $\mathbf{x}$
$\max_x f(x)$	Value of $x$ that maximize $f(x)$
$\min_x f(x)$	Value of $x$ that minimize $f(x)$
<i>s.t.</i>	Subject to
$\mathcal{O}(\cdot)$	Order of the number of computation steps
$\frac{\partial f(x,y)}{\partial x}$	Partial derivative of $f(x, y)$ with respect to $x$
$\partial f(x)$	Set of subgradients of $f$ at $x$
$\triangleq$	Equal by definition

# Introduction

*”Before you start some work, always ask yourself three questions - Why am I doing it, What the results might be and Will I be successful. Only when you think deeply and find satisfactory answers to these questions, go ahead” Chanakya.*

## Contents

---

<b>1.1 Motivation and Scope</b> . . . . .	<b>1</b>
<b>1.2 Organization of the Dissertation</b> . . . . .	<b>4</b>
<b>Bibliography</b> . . . . .	<b>8</b>

---

## 1.1 Motivation and Scope

The rapid development in the communication systems can be visualized by a simple comparison between the first Morse symbols per second in telegraph communications in the mid of the 19th century and the 300 Mbps already considered in the long term evolution (LTE) [1]. The advent of new high data rate wireless standards and services as well as the continuous growth of the applications and consumers result an increasing in the demand for the frequency spectrum which is a limited natural resource that may not be able to accommodate the emerging technologies.

Currently, the frequency allocation is regulated by governmental agencies which apply the ”command-and-control” allocation model by providing an exclusive assignment of a fixed frequency block for each communication service. In addition to the spectrum allocation, these

agencies regulate the spectrum usage by specifying the type of service, the maximum transmission powers, and the duration of license. This static and inflexible spectrum licensing scheme as shown by practical measurements leads to inefficient use of the spectrum since the licensed users who have the permission to use a certain portion of the spectrum cannot necessarily exploit this resource at all times or locations and in the same time prohibits other users or service providers from accessing the unused spectrum [2].

To make a balance between the spectrum scarcity and the spectrum under-utilization, the dynamic spectrum access (DSA) scheme has been proposed to replace the current inadequate spectrum licensing scheme [3]. By DSA, spatio/temporal spectrum opportunities<sup>1</sup> allocated originally to a certain licensed<sup>2</sup> user can be accessed and utilized by other unlicensed<sup>3</sup> users aiming to maximize the utilization of the spectrum while accommodating the increasing number of services [4,5]. The unlicensed users must be sufficiently agile in order to improve the spectrum efficiency [6], and should adapt to the conditions of the spectrum opportunities and guarantee the rights of the licensed users. Cognitive radio (CR) has been received a significant attention as the enabling technology for DSA by providing the wireless system with the required capability to adapt its parameters intelligently according to the surrounding environment and users requirements to achieve a highly reliable communications [4, 5, 7].

The major functionalities of a CR system include spectrum sensing, spectrum management and spectrum mobility. By spectrum sensing [8, 9], CR detects the licensed users activity to determine the spectrum opportunities. Additionally, CR is required to sense the spectrum during the unlicensed user transmission to avoid the collision with reappeared licensed user. Through spectrum management, the spectrum opportunities are analyzed and the spectrum access decisions are performed. The available system resources are optimized to achieve the required objectives and performance. The spectrum mobility changes the operational frequency bands when the status of the target spectrum changes. Several testbeds [10–13] and experiments [14, 15] have demonstrated that the DSA with CR is a promising solution. However, there is still a long way to go before having a real CR system. A lot of work has to be performed in order to find efficient solutions to the open problems like the spectrum identification, the users coordination, and interference-free spectrum usage . In this dissertation, we focus on the

---

<sup>1</sup>The terms spectrum opportunities, spectrum holes, and white spaces are used interchangeably in the dissertation.

<sup>2</sup>Licensed users and primary users terms are used interchangeably in the dissertation.

<sup>3</sup>Unlicensed users, secondary users, and cognitive users are used interchangeably in the dissertation.

spectrum management function and aim to design efficient resource allocation algorithms in multicarrier based CR systems.

Multicarrier communications have several advantages over the single-carrier ones. It offers higher spectral efficiency and more robustness to the fading channel. Additionally, multicarrier systems have the flexibility to distribute the resources among different users with the capability to handle with the multipath channel and require simple channel equalization techniques. In CR systems, multicarrier communications are considered as promising technique because -in addition to the mentioned advantages- of its ability to operate in discontinuous bands by transmitting only on the spectrum opportunities while nulling (deactivating) the occupied spectrum [6, 16, 17]. The multicarrier transmission enables the control of the transmission parameters of each subcarrier to avoid inducing severe interference to the licensed users.

Orthogonal frequency division multiplexing (OFDM) is the most common multicarrier technique that is considered by several communication standards including IEEE 802.22 [18, 19] TV based cognitive system that develops an unlicensed wireless regional area network (WRAN) to exploit the unused TV bands. In spite of this, there are several factors that limit the achieved capacity in OFDM systems. The large frequency domain sidelobes of the OFDM signal produces high mutual interference to the adjacent licensed system due to the lack of the synchronization. Moreover, OFDM utilizes the transmission of the cyclic prefix (CP) to compact the effect of the multiple path propagation which reduces the overall spectral efficiency. To overcome the limitations of the OFDM, the light is shed again recently on the filter bank multicarrier (FBMC) system which was invented before the OFDM. FBMC systems have received limited attention in comparison with that devoted to OFDM due to the simple concept and low complexity of OFDM [6, 20]. In FBMC systems, the sidelobes of each subcarrier frequency response is reduced by using signals with high spectral containment. Additionally, FBMC doesn't require any CP extension and offers more robustness to the time and frequency offsets than OFDM. This dissertation highlights the advantages of using FBMC instead of OFDM in the physical layer of future CR systems.



## 1.2 Organization of the Dissertation

This dissertation tackles the problem of the resource management in multicarrier based CR systems. The aim is to design efficient subcarrier and power allocation algorithms in order to maximize the system capacity while guarantee that the interference introduced to the licensed system is not harmful. The dissertation consists of six chapters written in way that every chapter has its own reference list. The organization of the dissertation is as follows

- **Chapter 2.** This chapter introduces the basic background of several concepts that is used in the dissertation. First, an overview of the CR system is presented. The CR characteristics and architectures are discussed and also the CR standardization efforts are reviewed. Next, the multicarrier systems structure and implementation are described. Different transmission schemes are outlined (OFDM, FBMC, and non orthogonal frequency division multiplexing (NOFDM)) and the resource allocation problem is reviewed. The last part of this chapter is devoted to the description of some optimization concepts and algorithms that are applied in the next chapters.
- **Chapter 3.** This chapter considers the resource allocation problem in downlink scenario. The allocation is performed subject to both the total power and interference constraints. The optimal solution is derived and a computationally efficient suboptimal scheme is proposed. The advantage of enable the CR system to use active as well as non-active licensed bands, is verified. The FBMC physical layer is compared with the OFDM one to prove its efficiency.

The contributions of this chapter are published in part on one journal, one book chapter and four international conferences:

- **M. Shaat** and F. Bader, "Computationally efficient power allocation algorithm in multicarrier-based cognitive radio networks: OFDM and FBMC systems," *EURASIP Journal on Advances in Signal Processing*, vol. 2010, Article ID 528378, 13 pages, 2010.
- **M. Shaat** and F. Bader, "Power allocation with interference constraint in multicarrier based cognitive radio systems," *Book Title: Multi-Carrier Systems and Solutions. Chapter 4: Adaptive Transmission*. Eds. Plass, S.; Dammann, A.; Kaiser, S.; Fazel, K. Springer 2009. ISBN: 978-90-481-2529-6 (HB). Netherlands.

- **M. Shaat** and F. Bader, "Low complexity power loading scheme in cognitive radio networks: FBMC capability," in *IEEE 20th International Symposium on Personal, Indoor and Mobile Radio Communications (PIMRC'09)*, Tokyo-Japan, Sept. 2009.
- **M. Shaat** and F. Bader, "A two-step resource allocation algorithm in multicarrier based cognitive radio systems," in *IEEE Wireless Communications and Networking Conference (WCNC'10)*, Sydney-Australia, April 2010, pp. 1–6.
- **M. Shaat** and F. Bader, "Power allocation and throughput comparison in OFDM and FBMC based cognitive radio," in *Proceeding of 22nd Meeting of the Wireless World Research Forum (WWRF'09)*, Paris-France, May 2009.
- **M. Shaat** and F. Bader, "Downlink resource allocation algorithm in OFDM/FBMC cognitive radio networks," in *the 3rd Mosharaka International Conference on Communications, Signals and Coding (MICCSC'09)*, Amman-Jordan, Nov. 2009.

- **Chapter 4.** This chapter develops the algorithm presented in chapter 3 to be used in uplink scenario where the problem become more complicated due to the individual power constraints for every unlicensed user. The interference introduced to the licensed band is not only induced by a single source like the downlink case but it is introduced by several nodes that are transmitting on the available spectrum holes. The allocation is performed in order to achieve fairness among different users. Efficient suboptimal algorithm is presented and the capability of FBMC in the CR system is shown.

The contributions of this chapter are published in part on one journal and three international conferences:

- **M. Shaat** and F. Bader, "Efficient resource allocation algorithm for uplink in multicarrier-based cognitive radio networks with fairness consideration," accepted in *IET Communications*.
- **M. Shaat** and F. Bader, "An uplink resource allocation algorithm for OFDM and FBMC based cognitive radio systems," in *Proceedings of the Fifth International Conference on Cognitive Radio Oriented Wireless Networks Communications (CROWN-COM'10)*, Cannes-France, June 2010, pp. 1–6.
- **M. Shaat** and F. Bader, "Fair and efficient resource allocation algorithm for uplink multicarrier based cognitive networks," in *IEEE 21st International Symposium on*

*Personal Indoor and Mobile Radio Communications (PIMRC'10)*, Istanbul-Turkey, Sept. 2010, pp. 1212–1217.

- **M. Shaat** and F. Bader, “Efficient uplink subcarrier and power allocation algorithm in cognitive radio networks,” in *7th International Symposium on Wireless Communication Systems (ISWCS'10)*, York-UK, Sept. 2010, pp. 223–227

- **Chapter 5.** This chapter deals with the resource allocation problem in relayed CR system. The scenario of dual-hop multi-relay decode-and-forward (DF) multicarrier based CR system is considered. An asymptotically optimal resource allocation algorithm is derived. The subcarriers pairing, power allocation and relay assignment are optimized jointly in order to maximize the system capacity under the interference and per-relay power constraints. Additionally, an efficient greedy suboptimal algorithm is developed to reduce the computational complexity of the optimal scheme. The efficiency of using FBMC instead of OFDM is also verified.

The contributions of this chapter are published in part on one journal paper, four international conferences and one conference paper under review:

- **M. Shaat** and F. Bader, “Asymptotically optimal resource allocation in OFDM-based cognitive networks with multiple relays,” accepted in *IEEE Transactions on Wireless Communications*.
- **M. Shaat** and F. Bader, “Joint Resource Optimization in Decode and Forward Multi-relay Cognitive Network With Direct Link,” *Submitted to IEEE Wireless Communications and Networking Conference, (WCNC'12)*, Paris-France.
- **M. Shaat** and F. Bader, “Optimal power allocation algorithm for OFDM-Based decode-and-Forward dual- Hop cognitive systems,” in *IEEE 73rd Vehicular Technology Conference (VTC Spring)*, Budapest-Hungary, May 2011, pp. 1–5.
- **M. Shaat** and F. Bader, “Optimal and suboptimal resource allocation for two-Hop OFDM-Based multi-Relay cognitive networks,” in *IEEE 22nd International Symposium on Personal, Indoor and Mobile Radio Communications (PIMRC'11)*, Toronto-Canada, Sept. 2011, pp. 477–481.
- **M. Shaat** and F. Bader, “Optimal resource allocation in multi-Relay cognitive networks using dual decomposition,” in *ICT-ACROPOLIS Network of Excellence*

*Workshop on "Cognitive Radio and Networking: Challenges and Solutions Ahead" jointly located with IEEE 22nd International Symposium on Personal, Indoor and Mobile Radio Communications (PIMRC'11), Toronto-Canada, Sept. 2011, pp. 2335–2339.*

- **M. Shaat** and F. Bader, "Joint subcarrier pairing and power allocation for DF-Relayed OFDM cognitive systems," to appear in *IEEE Global Telecommunications Conference (GLOBECOM'11)*, Houston-USA, Dec. 2011.
- **Chapter 6.** This chapter concludes the dissertation by summarizing the main research challenges and highlighting the main achieved results. The future work is outlined at the end of this chapter.

## Bibliography

- [1] 3GPP TSG RAN TS 36.211, “Physical channels and modulation,” *Release 8, v. 8.4.0*, Feb. 2009.
- [2] Federal Communication Commission, “Spectrum Policy Task Force,” Report of ET Docket 02-135, Nov. 2002.
- [3] Qing Zhao and B.M. Sadler, “A survey of dynamic spectrum access,” *IEEE Signal Processing Magazine*, vol. 24, no. 3, pp. 79–89, May 2007.
- [4] S. Haykin, “Cognitive radio: brain-empowered wireless communications,” *IEEE Journal on Selected Areas in Communications*, pp. 201–220, Feb. 2005.
- [5] I. Akyildiz, L. Won-Yeol, M.C. Vuran, and S. Mohanty, “NeXt generation/dynamic spectrum access/cognitive radio wireless networks: A survey,” *Computer Networks*, vol. 50, no. 13, pp. 2127 – 2159, 2006.
- [6] H. Bogucka, A.M. Wyglinski, S. Pagadarai, and A. Kliks, “Spectrally agile multicarrier waveforms for opportunistic wireless access,” *IEEE Communications Magazine*, vol. 49, no. 6, pp. 108–115, 2011.
- [7] III Mitola, J. and Jr. Maguire, G.Q., “Cognitive radio: making software radios more personal,” *IEEE Personal Communications*, vol. 6, no. 4, pp. 13–18, Aug 1999.
- [8] T. Yucek and H. Arslan, “A survey of spectrum sensing algorithms for cognitive radio applications,” *IEEE Communications Surveys Tutorials*, vol. 11, no. 1, pp. 116–130, First quarter 2009.
- [9] Y. Zeng, Y-C. Liang, A. Hoang, and R. Zhang, “A review on spectrum sensing for cognitive radio: Challenges and solutions,” *EURASIP Journal on Advances in Signal Processing*, vol. 2010, Article ID 381465, 15 pages, 2010.
- [10] S.M. Mishra, D. Cabric, C. Chang, D. Willkomm, B. Van Schewick, S. Wolisz, and BW Brodersen, “A real time cognitive radio testbed for physical and link layer experiments,” in *First IEEE International Symposium on New Frontiers in Dynamic Spectrum Access Networks (DySPAN’05)*, 2005, pp. 562–567.

- [11] KE Nolan, PD Sutton, LE Doyle, TW Rondeau, B. Le, and CW Bostian, “Dynamic spectrum access and coexistence experiences involving two independently developed cognitive radio testbeds,” in *2nd IEEE International Symposium on New Frontiers in Dynamic Spectrum Access Networks (DySPAN’07)*, 2007, pp. 270–275.
- [12] Z. Yan, Z. Ma, H. Cao, G. Li, and W. Wang, “Spectrum sensing, access and coexistence testbed for cognitive radio using usrp,” in *4th IEEE International Conference on Circuits and Systems for Communications (ICCSC’08)*, 2008, pp. 270–274.
- [13] E. Pappas, S. Boettcher, C. Mascaro, and S. Thai, “Spectrum simulation testbed for dynamic spectrum access,” in *3rd IEEE International Symposium on New Frontiers in Dynamic Spectrum Access Networks (DySPAN’08)*, 2008, pp. 1–5.
- [14] R.J. DeGroot, D.P. Gurney, K. Hutchinson, M.L. Johnson, S. Kuffner, A. Schooler, S.D. Silk, and E. Visotsky, “A cognitive-enabled experimental system,” in *First IEEE International Symposium on New Frontiers in Dynamic Spectrum Access Networks (DySPAN’05)*, 2005, pp. 556–561.
- [15] M. McHenry, E. Livsics, T. Nguyen, and N. Majumdar, “XG dynamic spectrum access field test results,” *IEEE Communications Magazine*, vol. 45, no. 6, pp. 51–57, 2007.
- [16] T. Weiss and F. K. Jondral, “Spectrum pooling: An innovative strategy for the enhancement of spectrum efficiency,” *IEEE Communications Magazine*, vol. 42, pp. S8 – S14, March 2004.
- [17] B. Farhang-Boroujeny and R. Kempter, “Multicarrier communication techniques for spectrum sensing and communication in cognitive radios,” *IEEE Commun. Mag. (Special Issue on Cognitive Radios for Dynamic Spectrum Access)*, vol. 48, no. 4, pp. 80–85, Apr. 2008.
- [18] IEEE 802.22 Working Group, “IEEE 802.22 D1: Draft standard for wireless regional area networks,” March 2008.
- [19] C. Cordeiro, K. Challapali, D. Birru, and N. Sai Shankar, “IEEE 802.22: the first worldwide wireless standard based on cognitive radios,” in *First IEEE International Symposium on New Frontiers in Dynamic Spectrum Access Networks (DySPAN’05)*, Nov. 2005, pp. 328–337.

- [20] B. Farhang-Boroujeny, "OFDM versus filter bank multicarrier," *IEEE Signal Processing Magazine*, vol. 28, no. 3, pp. 92–112, 2011.

# Background

*”To know that we know what we know, and that we do not know what we do not know, that is true knowledge”* **Henry David Thoreau.**

## Contents

---

<b>2.1</b>	<b>Cognitive Radio Overview</b>	<b>12</b>
2.1.1	Cognitive Radio Definition and Characteristics	12
2.1.2	Cognitive Radio Functions	14
2.1.3	Dynamic Spectrum Access	17
2.1.4	Interference Temperature Model	20
2.1.5	Cognitive Radio Standardization	22
<b>2.2</b>	<b>Multicarrier Systems Overview</b>	<b>24</b>
2.2.1	Orthogonal Frequency Division Multiplexing (OFDM) system	24
2.2.2	Filter Bank Multicarrier (FBMC) system	28
2.2.3	Structure and Implementation of OQAM-OFDM	32
2.2.4	Non Orthogonal Frequency Division Multiplexing (NOFDM) Systems	37
2.2.5	Summary of OFDM and FBMC Differences	40
<b>2.3</b>	<b>Resource Management in Multicarrier Systems</b>	<b>41</b>
2.3.1	Resource Allocation in Single User Multicarrier systems	42
2.3.2	Resource Allocation in Multi-user Multicarrier systems	43
<b>2.4</b>	<b>Constrained Optimization</b>	<b>45</b>
2.4.1	Lagrangian Method and Optimality Conditions	47
2.4.2	Interior Point Method	48
2.4.3	Subgradient Method	49
2.4.4	Duality	50
	<b>Bibliography</b>	<b>53</b>

---



## 2.1 Cognitive Radio Overview

Since the early twentieth century, the electromagnetic spectrum is regulated by the governments in most of the countries where the available spectrum is divided into several frequency bands that are allocated traditionally to a specific user or service provider exclusively in order to be protected from any interference. Since most of the current frequency bands have been already allocated [1], it will be very hard to find vacant bands for the emerging wireless systems or services. Moreover, recent measurements by the Federal Communications Commission (FCC) show that the spectrum utilization in the 0-6 GHz band varies from 15 to 85% depending on time, frequency and geographical location as shown in Fig. 2.1 [2, 3]. These observations motivate the development of the cognitive radio (CR) [4, 5] and to modify the current static spectrum access policies accordingly in order to overcome the spectrum scarcity and under-utilization problems.

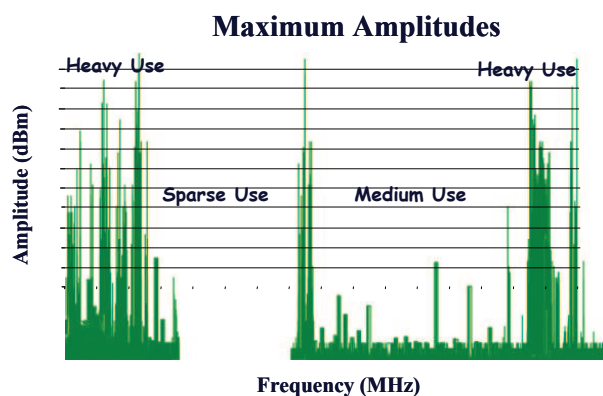


Figure 2.1: Spectrum utilization [3].

### 2.1.1 Cognitive Radio Definition and Characteristics

A soft-defined radio (SDR) is a wireless communication system which can be reconfigured by software reprogramming to operate on different frequencies with different protocols [6]. CR is generally implemented based on SDR platform. The term CR means different thing to different audiences. The concept was first introduced by Mitola as *"The point in which wireless personal digital assistants and the related networks are sufficiently computationally intelligent about radio resources and related computer to computer communications to detect user communication needs as a function of use context, and to provide radio resources and*

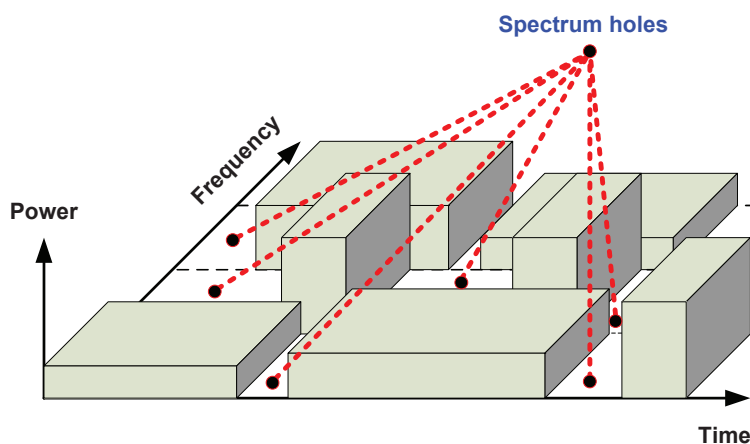
wireless services most appropriate to those needs” [4]. Other definitions of CR were provided in [2, 5, 7] as follows

- **FCC in [2]:** *”CR is a radio that can change its parameters based on interaction with the environment in which it operates” .*
- **Haykin in [5]:** *”Cognitive radio is an intelligent wireless communication system that is aware of its surrounding environment (i.e., outside world), and uses the methodology of understanding-by-building to learn from the environment and adapt its internal states to statistical variations in the incoming RF stimuli by making corresponding changes in certain operating parameters (e.g., transmit power, carrier-frequency, and modulation strategy) in real-time, with two primary objectives in mind: highly reliable communications whenever and wherever needed and efficient utilization of the radio spectrum”.*
- **Jondral in [7]:** *”CR is an SDR that additionally senses its environment, tracks changes, and reacts upon its findings. A CR is an autonomous unit in a communication environment that frequently exchanges information with the networks it is able to access as well as with other CRs”.*

From these definitions, CR has two main characteristics [3, 5]

1. **Cognitive capability:** which is the ability to acquire the radio parameters from its surroundings. CR should be able to determine the frequency occupancy by identifying the spectrum holes (or spectrum opportunities). The spectrum hole is defined as the frequency bands which are allocated but not utilized in some location and at some times by the licensed system as given in Fig 2.2. Moreover, depending on the system, CR might have information about the modulation and coding as well as the geolocation of the licensed system devices.
2. **Reconfigurability:** which is the ability to rapidly adapt the transmit parameters ,i.e. operating frequency, modulation and coding, transmit power and communication technology, according to the radio environment in order to achieve the optimal performance.

To perform the required CR characteristics, in addition to the SDR based RF front-end in the CR physical (PHY) layer, the different protocols in medium access control (MAC), net-



**Figure 2.2:** Spectrum holes (or spectrum opportunities).

works, transport and application layers should be adaptive to the variation in the CR environment like the licensed user activity, cognitive system requirements and the channel qualities. On top of that, a CR module is used to establish the interfaces among the different layers and control the protocol parameters based on intelligent algorithms [8].

### 2.1.2 Cognitive Radio Functions

The CR network has two main components: the primary network and the secondary one. The primary network, also referred to as licensed network, has a license to operate in a certain frequency band. It consists of primary users (PUs) with/without primary base stations (BSs). PUs are generally not equipped with any CR functions. On the other side, the secondary network is able to share/access the licensed spectrum without affecting the primary network transmission. The secondary network is composed of secondary users (SUs) with/without secondary BS. Additionally, spectrum broker can be used to enable efficient and fair spectrum sharing between multiple secondary networks coexist in the same frequency band.

To support this type of spectrum sharing between the primary and cognitive networks, and to guarantee efficient usage of the resources in both networks, CR is required to perform the following four functions

1. **Spectrum sensing:** by this function, the CR monitors its radio environment in order to identify the PUs activity. Based on the sensing information, CR can determine the available spectrum holes that can be used for the CR transmission in a particular time,

frequency, and location. Furthermore, the CR need to keep sensing the frequency spectrum during the CR transmission to avoid interfering with reappeared PUs.

Spectrum sensing can be performed in either centralized or distributed ways. In centralized spectrum sensing, a central unit, also called sensing controller, is in charge of the sensing process. The sensing information is shared with the different SUs using a control channel. Although that the centralized approach reduces the complexity of the SUs devices, it suffers from the hidden/far PUs detection problem. The SUs are performing the spectrum sensing in the distributed way. Depending on the level of cooperation in the network, each SU can take the decision based on his sensing information (non-cooperative sensing) or based on the sensing information shared with the other nodes in the network (cooperative spectrum sensing (see e.g. [9–13] and references therein). Moreover, a central unit can collect the distributed sensing information to control the cognitive traffic [14]. The cooperative spectrum sensing is more accurate and can reduce the primary signal detection time [9, 10, 15]. However, cooperative introduces additional signaling overhead which increases with the number of SUs and with fast varying spectrum usage [16, 17].

Depending on the detected signal, spectrum sensing can be categorized into the following two main groups

- *Primary transmitter detection*: where the sensing is performed over the weak signal received at the CR terminal from the primary transmitter. The increasing in the distance between the CR terminal and the primary transmitter as well as the shadowing degrades the performance of this type of sensing. Cooperation between nodes improve the performance and the accuracy. The typical practical schemes used for primary transmitter detection are: matched filter detection, energy detection and cyclostationary feature detection. The matched filter detection is the optimal when the CR terminal has a priori knowledge of the waveform of the PU . Energy detector is the most common type of the spectrum sensing because of its implantation simplicity besides to that it requires no prior information about the PU signal. However, its relatively slow, sensitive to the noise, and cannot distinguish between the PU and SU signals [16–18]. Eventually, cyclostationary feature detection uses the build-in periodicity in primary signal to detect the primary transmitter by analyzing

the spectral correlation function. Its robust to the noise power uncertainty but it has a high computational cost and requires long observation times [19–23]. The advantages and disadvantages of these sensing schemas are summarized in Table. 2.1.

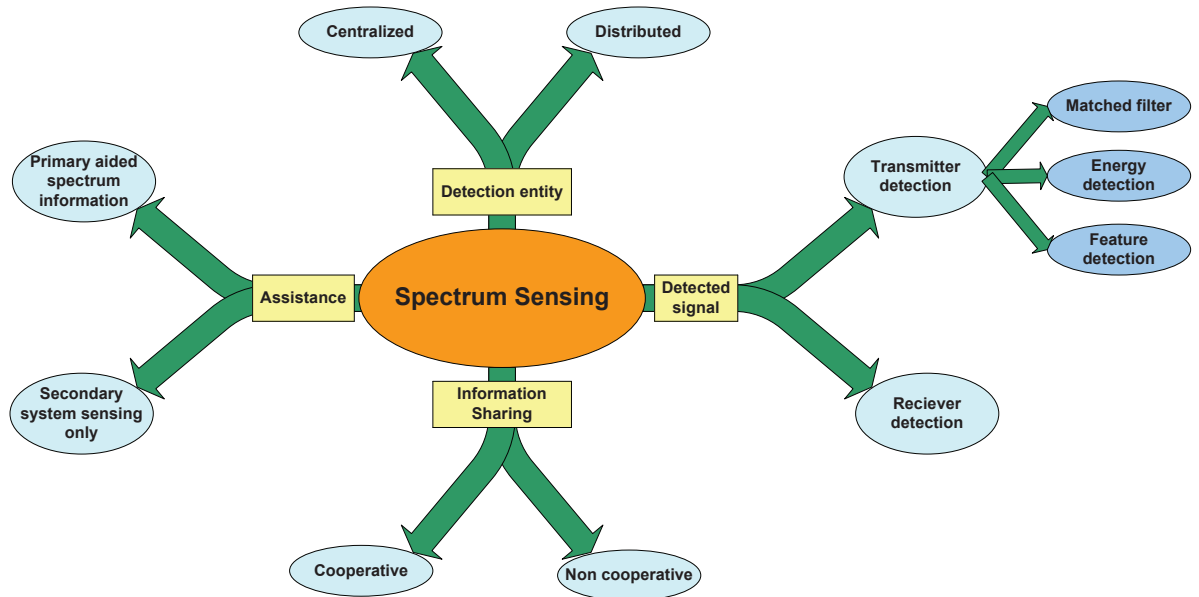
- *Primary receiver detection*: this type of sensing detects the local oscillator leakage power emitted by the RF front-end of the primary receiver [24]. Currently, this method is only feasible in the detection of the TV receivers [3].

In [25–27], the possibility of active agreement between the secondary network and the primary system to share the spectrum occupancy information is discussed. This kind of network-aided approach may help the secondary network to have a perfect channel information but it requires additional modifications to the existing primary networks which may not be possible. Fig. 2.3 summarizes the classifications of the spectrum sensing approaches.

2. **Spectrum decision**: this function analyzes the information from the spectrum sensing phase. The characteristics of the detected spectrum holes, the probability of the PU appearance, and the possible sensing errors should be considered before making the spectrum access decision. Once the appropriate band is selected, the CR has to optimize the available system resources in order to achieve the required objective.

**Table 2.1:** Comparison of the primary transmitter detection techniques.

Sensing Approach	Advantages	Disadvantages
<i>Matched filter detection</i>	<ul style="list-style-type: none"> <li>- Optimal Performance</li> <li>- Fast detection and low cost</li> <li>- Robust to the noise uncertainty</li> <li>- Requires low number of samples</li> </ul>	<ul style="list-style-type: none"> <li>- Prior knowledge of the primary signal</li> <li>- High complexity</li> </ul>
<i>Energy detection</i>	<ul style="list-style-type: none"> <li>- No prior information is required</li> <li>- Low cost</li> <li>- Easy to implement</li> </ul>	<ul style="list-style-type: none"> <li>- Unreliable in Low SNR regime</li> <li>- High False Alarm</li> <li>- Cannot differentiate PU signal from other SUs</li> <li>- Doesn't work for spread spectrum signals</li> </ul>
<i>Feature detection</i>	<ul style="list-style-type: none"> <li>- Robust to noise uncertainty and performs well in low SNR regimes.</li> <li>- Can differentiate between several types of transmissions</li> </ul>	<ul style="list-style-type: none"> <li>- Partial knowledge of the primary signal</li> <li>- High computational complexity</li> </ul>



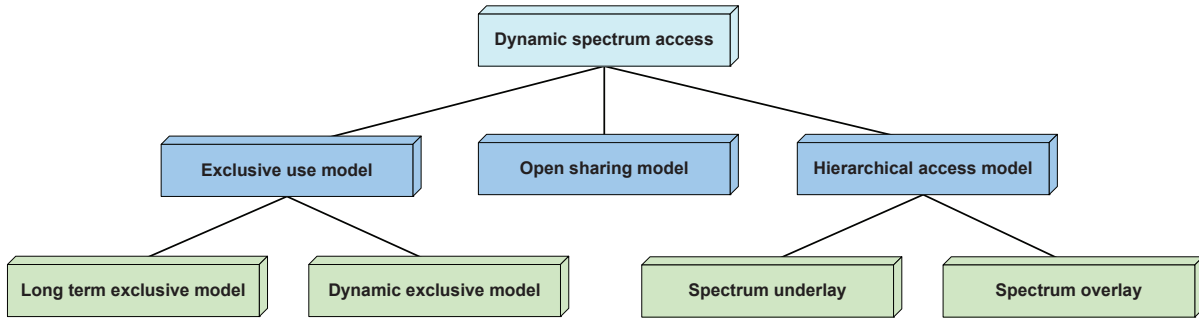
**Figure 2.3:** A taxonomy of spectrum sensing.

3. **Spectrum sharing:** this function choose the appropriate MAC protocol to access the spectrum holes. By the MAC protocol, fair spectrum sharing between the different SUs can be guaranteed. Additionally, coordination between nodes can be achieved in order to avoid the collision with PUs as well as other SUs.
4. **Spectrum mobility:** also called spectrum handover and by this function, CR is able to change the operating band in order to avoid a detected PU activity. Additionally, the CR can perform the spectrum handover in order to improve the secondary network performance by transmitting in another spectrum hole with better condition. The protocol parameters at the different levels should be adapted according to the new operating band.

### 2.1.3 Dynamic Spectrum Access

Dynamic spectrum access (DSA) is standing on the opposite of the current inflexible spectrum licensing scheme and represents the mechanisms to adjust the spectrum usage in response to the different changes (environment, objectives, radio state, constraints, etc.) [28]. Based on the DSA, the functionality of the secondary network access protocol as well as the coexistence characteristics between the primary and secondary networks are defined. As described in Fig. 2.4, existing DSA schemes can be broadly classified into three main models:

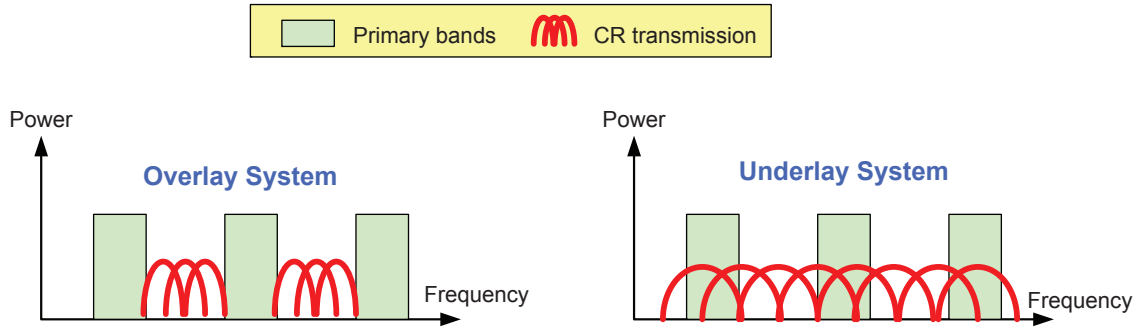
1. **Exclusive-use model:** in this model, the radio spectrum is licensed to user/service exclu-



**Figure 2.4:** A taxonomy of dynamic spectrum access [29].

sively in a similar way to that used in the static spectrum allocation policy. The difference is in the flexibility introduced by allowing the spectrum owner to grant the cognitive users a spectrum access right to the non-utilized bands. Two approaches have been proposed under this model:

- *Long term exclusive model*: this model was first proposed by the European project DRiVE (Dynamic Radio for IP-Services in Vehicular Environments) in order to improve the spectrum efficiency through dynamic spectrum allocation depending on the temporal and traffic statistics [30]. Afterwards, this approach is considered by several researchers (e.g. see [31–34] and references therein) to assign the spectrum exclusively to a given service in a given region and at a given time. The cognitive network can change the type of the wireless services and the spectrum access parameters during the licensed time in the *flexible-type sub-model* which is not the case in the *fixed-type sub-model*.
- *Dynamic exclusive model*: the spectrum owner in this model can trade its own spectrum by selling or leasing it and thus can get revenue. This type of trading is called the secondary market (e.g. see [35–40] and references therein). The secondary market has three main categories. The first one is called *non-real-time secondary market* where the trading and the spectrum allocation are performed before the spectrum is accessed. The other two types are called *real-time secondary markets for homogeneous and for heterogeneous multi-operator sharing* where the spectrum can be traded and allocated in on-demand basis. Unlike the homogeneous multi-operator sharing, the heterogeneous one allows that the type of the wireless service can be different between the spectrum owner and the secondary network. Note that



**Figure 2.5:** Overlay and underlay spectrum access techniques.

the *Dynamic exclusive model* is also called *spectrum property rights model* [29,35].

2. **Open sharing model:** also called *spectrum commons* [29,41], the CRs in this model have the same rights to access the radio spectrum. The spectrum can be not owned by any entity which called the *uncontrolled-commons sub-model* like the access to the unlicensed industrial,scientific and medical (ISM) and unlicensed national information infrastructure (U-NII) bands. The cognitive radios access can be controlled by a management protocol which called the *managed-commons sub-model*. The protocol should minimize the communication overheads and promote fair spectrum access among the cognitive radios [41,42]. When the cognitive radios access technology and protocol are specified by the spectrum owner, the sub-model is called *private-commons*. The peer-to-peer cognitive communications is an example of this model. To address the technological challenges under this model, centralized [43,44] and distributed [45,46] spectrum sharing strategies have been investigated.
3. **Hierarchal access model:** this model distinguishes between the modes in which the secondary network can access the spectrum. The secondary system can use the spectrum unless the primary system transmission is interrupted. The secondary network should not introduce harmful interference to the primary network. As described in Fig. 2.5, the hierarchal access structure is adopted to classify the spectrum sharing modes into two main approaches
  - *Spectrum overlay:* this model enable the secondary network to access opportunistically the spectrum holes left by the primary network [47–52]. The secondary user should perform the spectrum sensing in order to detect the available spectrum holes.



The probability of the sensing errors as well as the out of band interference should be considered before/during the transmission [53].

- *Spectrum underlay*: the primary and cognitive networks transmit simultaneously using the same frequency band in this model. However, the transmission power of the secondary system should be limited in order to operate in the noise floor of the primary system. Therefore, spectrum underlay can be applied in the short range applications where high data rate can be achieved with the low transmission power. The code division multiple access (CDMA) and ultra wide band (UWB) technologies can be used in this spectrum sharing model.

#### 2.1.4 Interference Temperature Model

Constraining the SUs transmitter power to guarantee that no harmful interference introduced to the licensed system is a challenging issue. Using of restrictive constraints may reduce spectrum holes utilization which opposes the CR aim. On the other hand, more relaxed constraints may cause a degradation of the primary system performance. FCC [2] has proposed a metric called *interference temperature* to quantify the interference introduced to the licensed users in a particular time and at a particular location, and is defined as the temperature equivalent to the RF power available at the receiving antenna per unit bandwidth [54, 55]. The *interference temperature* is specified in Kelvin and is expressed as

$$T_I(f_c, B) = \frac{P_I(f_c, B)}{kB} \quad (2.1)$$

where  $P_I(f_c, B)$  is the average interference power in Watts centered at  $f_c$ , covering the bandwidth  $B$  measured in Hertz, and  $k$  is the Boltzmann's constant ( $k = 1.38 \times 10^{-23}$  Joules per Kelvin degree).

As shown in Fig. 2.6 , the interference temperature model shows that the signal of the CR have to be designed to operate in a range at which the received power by PUs approaches the level of noise floor. The peaks above the original noise floor indicates that the noise floor increases at various points due to the appearance of additional interfering signals [3]. Based on this model, an *interference temperature limit*  $T_L$  is determined, which provides a maximum amount of the interference that the licensed user can tolerate. The multitaper method can be used to have a spectral estimate of the interference temperature with a large number of sensors

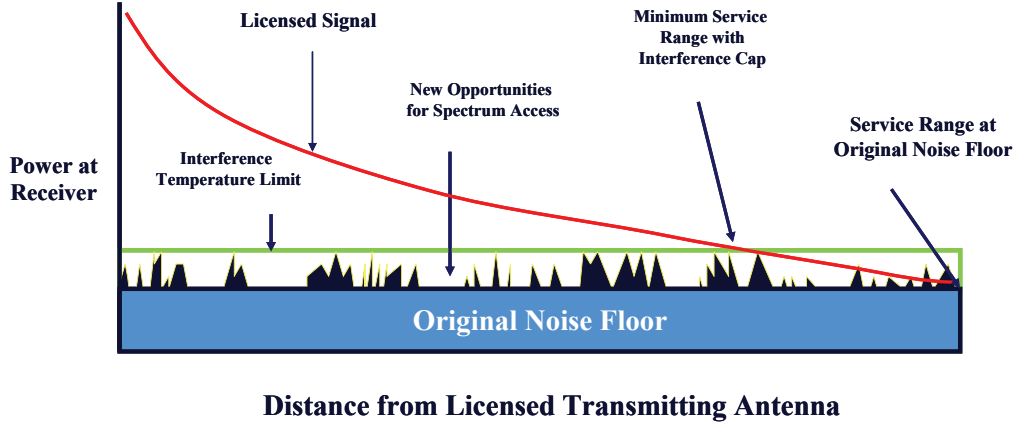


Figure 2.6: Interference temperature model [2].

[5]. The large number of sensors can account for the spatial variation of the RF-energy from one location to another [5]. Additionally, subspace-based method can provide knowledge about the quality of usage of the spectrum band where information about the interference temperature is obtained by eigenvalue decomposition [56].

Based on the ability of the secondary system to identify the licensed signal as well as the ability to measure the interference floor, ideal and generalized interference temperature models are considered [55].

- **Ideal interference temperature model:** in this model, the cognitive transmission should not violate the interference temperature limit at the different licensed receivers. Assume that the secondary system transmitter is operating with average power  $P$ , and frequency  $f_c$ , with bandwidth  $B$ . Assume also that this transmission frequency band overlaps  $n$  licensed signals with respective frequencies of  $f_i$  and  $B_i$ . Therefore, the target is to guarantee that

$$T_I(f_i, B_i) + \frac{M_i P}{k B_i} \leq T_L(f_i) \quad \forall i \in \{1, \dots, n\} \quad (2.2)$$

where  $0 \leq M_i \leq 1$  is a multiplicative attenuation factor due to path loss and fading in the link between the secondary system transmitter and the licensed receiver.

For the ideal interference model, the waveform of the licensed users signals has to be known at the secondary system transmitter in order to able to distinguish the licensed signals from the the unlicensed ones. Additionally, the waveform structure knowledge help the secondary user to determine the transmit and salience portions of the licensed signals and thus measure the interference floor.

- **Generalized interference temperature model:** this model is used when there is no a priori knowledge of the licensed user signal. In this case, the signals from the primary and secondary systems cannot be differentiated. Therefore, the interference temperature model should be applied to the entire frequency range, and not just where the licensed signals are detected. According to this model, the interference temperature limit can be defined as follows

$$T_I(f_c, B) + \frac{MP}{kB} \leq T_L(f_c) \quad (2.3)$$

From the equation above, one can notice that the constraint is expressed in terms of the parameters in secondary system transmitter where the licensed receivers ones are unknown.

A comprehensive study on the achievable capacity under the interference temperature model has been proposed in [57,58], which shows that the achieved capacity is a simple function of the number of the nodes, the average bandwidth, and the fractional impact to the primary signal's coverage area. It is found that using the interference temperature model to constrain the transmit power results in very poor performance. The results are improved significantly if the ideal model is adopted in conjunction with spectrum shaping [59] where a waveform with non-uniform power spectral density is used. Therefore, the portions of the waveform that overlap the licensed signal could be attenuated, while those non-overlapping portions could use a higher transmit power.

### 2.1.5 Cognitive Radio Standardization

The standardization is a key aspect of the success of the current and future CR systems. IEEE started the development of the first international CR standard in 2006. Meanwhile, IEEE have several ongoing work to improve the current standards to support the cognitive capability. In addition to the underway work of the IEEE, International Telecommunication Union (ITU), European Telecommunications Standards Institute (ETSI) and European association for standardizing information and communication systems (ECMA) are examples of other international organizations or associations who have made or are making standards for various application [60]. Within the IEEE, two major standards on CR are *IEEE 802.22* and *IEEE P1900*.

- **IEEE 802.22:** this standard [61,62] is the first worldwide standard on CR technology.

The main target of this standard is to enable the sharing of the TV spectrum with broadcast service in the low population rural areas. In this standard, not only the PHY and MAC layers are considered. But unlike other standards, it addresses an additional functions like the spectrum sensing functions and the geo-location one. Using the spectrum sensing function, the spectrum holes are identified while the geo-location one is determining the location of the cognitive devices. The location information is combined with a database of the primary transmitters to determine the available channels. The network BS is covering a geotropical area with 30 km radius and can support a maximum of 255 fixed units of customer premises equipment (CPE). The minimum downlink (BS to CPE) throughput is 1.5 Mb/s while the minimum in the uplink (CPE to BS) is 384 kb/s.

- **IEEE P1900:** this standard focuses on the next generation radio and spectrum management [63]. The standard considers the the advanced radio system technologies such as the CR systems, policy defined radio system, adaptive radio systems and related technologies. The standards consists of six working groups: *IEEE P1900.1* to define the glossary of the terms, *IEEE P1900.2* for the interference coexistence analysis, *IEEE P1900.3* for the evaluation of software modules in SDR to guarantee the compliance in the software part, *IEEE P1900.4* is the major working group which relates to coexistence support for the reconfigurable heterogenous air interface, *IEEE P1900.5* for the definition of the policy language and policy architectures, and finally, *IEEE P1900.6* to define the spectrum sensing interfaces as well as data structures for DSA systems.

In relation to the existed IEEE standards, the *IEEE 802.11 TGaf* group is established to make amendments to the PHY and MAC layers to support the channel access and coexistence in the TV white space [64, 65]. Moreover, a coexistence mechanisms of the operation of the Worldwide Interoperability for Microwave Access (WiMAX) in the license-exempt bands is developed within *IEEE 802.16h* standard [66]. Furthermore, within the IEEE 802 standard committee, the wireless coexistence technical advisory group *IEEE 802.19* is established to deal with the issue of the coexistence of different wireless networks within the same location [60]. An extensive review on the standardization activity within IEEE and other organization can be found on [17, 60, 67].

## 2.2 Multicarrier Systems Overview

The history of the multicarrier systems dates back to mid 1960s when Chang and Saltzberg presented the theory and the analysis of the parallel data transmission technique [68, 69]. The idea behind that is dividing the broadband band into parallel sub-bands, called subcarriers, where the high data rate stream is split into low-rate streams. As the number of subcarriers increases, the bandwidth of each subchannel becomes narrower which increases the ability of the communication system to overcome the problem imposed by frequency-selective channels. Every subcarrier is affected by a flat fading channel which reduces the receiver complexity.

CR requires a flexible and efficient physical layer. Multicarrier communications has been recommended as a candidate for future CR systems due its ability to perform underlying sensing as well as its capability to fill the spectrum gaps left by the PU. Moreover, multicarrier based CR systems can meet the spectrum shape requirements by deactivating (i.e. nulling) the subcarriers where the PU is currently transmitting or the subcarriers that can potentially interfere with other users. Additionally, the different system resources can be distributed and utilized efficiently to adapt the different transmission environments. The multicarrier systems offers very flexible multiple access and spectral allocation of the available spectrum which can be performed in the CR system without any extra hardware complexity. Several parameters can be adjusted in the system like subcarrier spacing, subcarrier number, modulation, coding and powers.

The orthogonal frequency division multiplexing (OFDM) and filter bank multicarrier (FBMC) are considered as physical layers for the CR in this dissertation. Therefore, the principles of OFDM and FBMC systems are described in the following. The advantages and disadvantages of each scheme are highlighted. Furthermore, the generalized multicarrier (GMC) framework is discussed.

### 2.2.1 Orthogonal Frequency Division Multiplexing (OFDM) system

In OFDM systems, the frequency spectrum of the subcarriers are overlapped with minimum frequency spacing and the orthogonality is achieved between the different subcarriers. The schematic diagram of the OFDM system is depicted in Fig. 2.7. Each OFDM symbol can be generated as follows. The bit stream is split into parallel data streams using the serial-to-

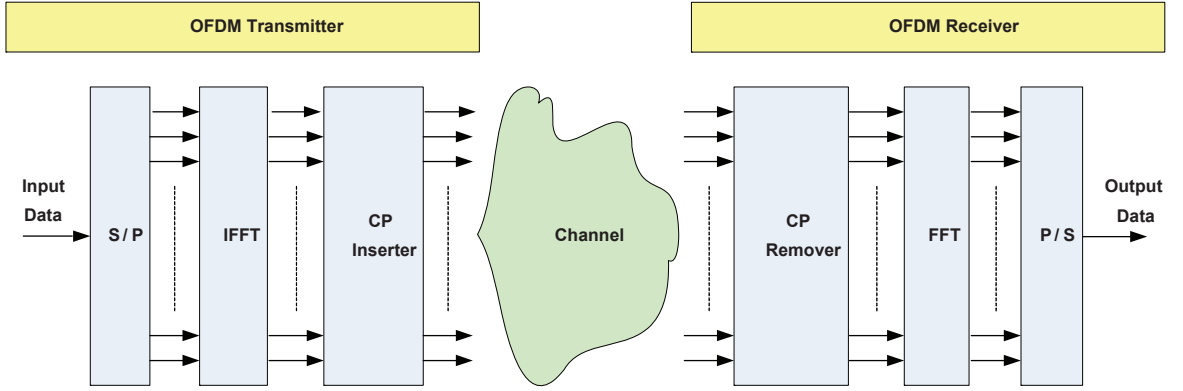


Figure 2.7: OFDM system block diagram.

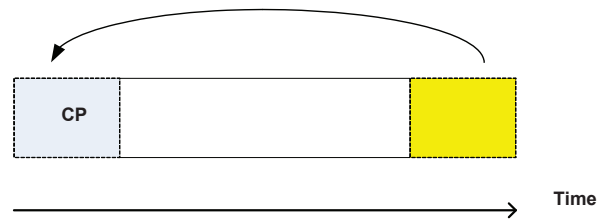


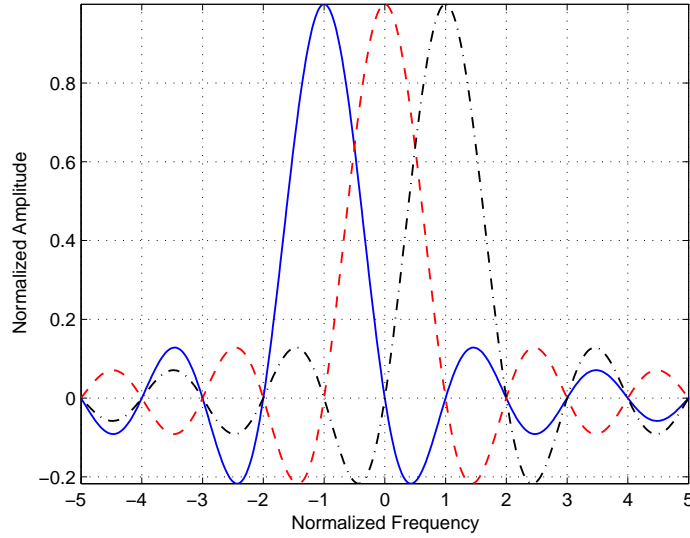
Figure 2.8: CP insertion in the OFDM symbol.

parallel (S/P) converter. Afterwards, the parallel streams are passed into an inverse fast Fourier transformation (IFFT) to generate a time sequence of the streams. Subsequently, the OFDM symbol time sequences are extended by adding a cyclic extension called the cyclic prefix (CP). The CP is a copy of the last part of the symbol that is added in the beginning of the sequences as given in Fig. 2.8 and should be larger than the network delay spread in order to mitigate the inter-symbol interference (ISI) generated by the arrival of different OFDM symbols with different delay. The resulting digital signal is converted into an analogue one and transmitted through the channel. At the receiver side, the signal is reconverted again into digital one and the fast Fourier transformation (FFT) is performed on the received streams after removing the CP. Finally, the parallel streams are gathered into single stream as the original transmitted one.

From the discussion above, the OFDM baseband equivalent is formed by taking the inverse discrete Fourier transform (IDFT) to a set of complex input symbols  $\{X_k\}$  and adding a cyclic prefix. This can be written mathematically as

$$x(n) = \sum_k \sum_{l \in \mathbb{Z}} X_{k,l} g_T(n - lT) e^{j2\pi(n-lT-C)k/N} \quad (2.4)$$

where  $\{k\}$  is the set of data subcarrier indices and is a subset of the set  $\{0, 1, \dots, N - 1\}$ ,  $N$  is the IDFT size,  $C$  is the length of the cyclic prefix in number of samples, and  $T = C + N$  is



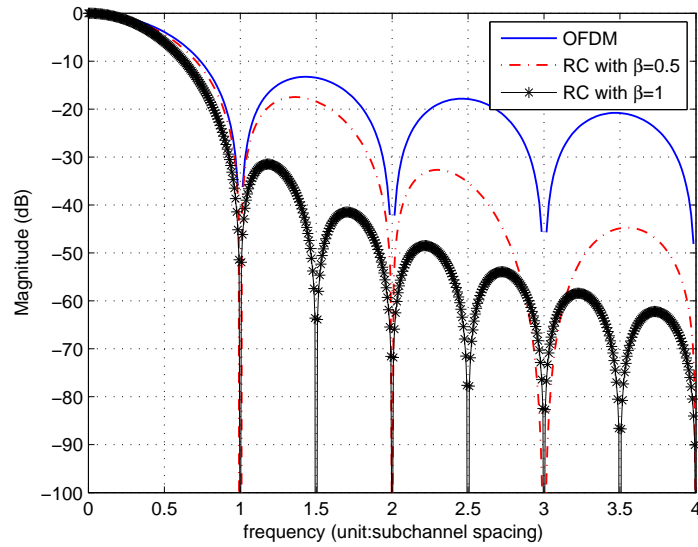
**Figure 2.9:** Frequency representation of three subcarriers in OFDM signal.

the length of the OFDM symbol in number of samples.  $l$  denotes the  $l^{\text{th}}$  OFDM symbol while  $g_T(n)$  is a rectangular pulse shape that can be expressed as

$$g_T(n) = \begin{cases} 1 & n = 0, 1, \dots, T - 1 \\ 0 & \text{otherwise} \end{cases} \quad (2.5)$$

Notice that any two subcarriers in OFDM are orthogonal in the time interval  $T$ . Fig. 2.9 shows the frequency representation of an OFDM signal. For each frequency multiple of  $\frac{1}{T}$ , there is only one of the subcarriers contribute to the OFDM signal whereas the rest are null at this frequency since the sinc shape in the frequency domain for a given subcarrier has zero matching with frequency allocation of the other subcarriers.

OFDM has been exploited in several wireless technologies due its attractive features. OFDM is considered currently in digital audio and video broadcasting standards, several wireless local access network (WLAN) (e.g. HIPERLAN2 and IEEE 802.11a/g) and broadband wireless access system (e.g. IEEE 802.16e, IEEE 802.20 and Long term evolution (LTE)). The multi-user version of the OFDM is called Orthogonal Frequency-Division Multiple Access (OFDMA). The multiple access is achieved by allocating a group of subcarriers to a given user. OFDMA and OFDM are used interchangeably throughout the dissertation.



**Figure 2.10:** Frequency response of OFDM and RC windowing OFDM with roll-off parameter  $\beta = 0.5$  and  $\beta = 1$ .

### Side-lobes Reduction in OFDM System

OFDM system is widely used due to its simple concept and low complexity. However, in addition to the CP insertion, the large sidelobes of the OFDM signal frequency response causes high interference to the adjacent unsynchronized subcarriers and considered as the major short-coming of the OFDM system specially in the CR context where the large sidelobes means more interference to the primary system. In the literature, many techniques have been developed to solve the large sidelobes problem [53, 70–80]. Instead of using a rectangular pulse to shape the OFDM symbol, a window with soft transition among successive symbols can be used. The raised cosine (RC) windowing is one of the well known techniques to reduce the OFDM sidelobes [70]. One of the drawback of this technique that it introduces a small reduction on sidelobes close to the mainlobe as given in Fig. 2.10. It is shown in [71] that the high sidelobe suppression using RC windowing requires a prohibitive length of the cosine tail (overhead). The windowing at the receiver side is another type of the windowing techniques that can be used as proposed in [72, 73]. It requires a suffix samples in addition to the CP which further reduces the bandwidth efficiency. Remark that windowing reduces delay spread tolerance too [74].

Adding a guard bands by nulling the subcarriers in the boundaries of the adjacent unsynchronized bands was proposed by Weiss et al. in [53]. Its clear that this method reduces the



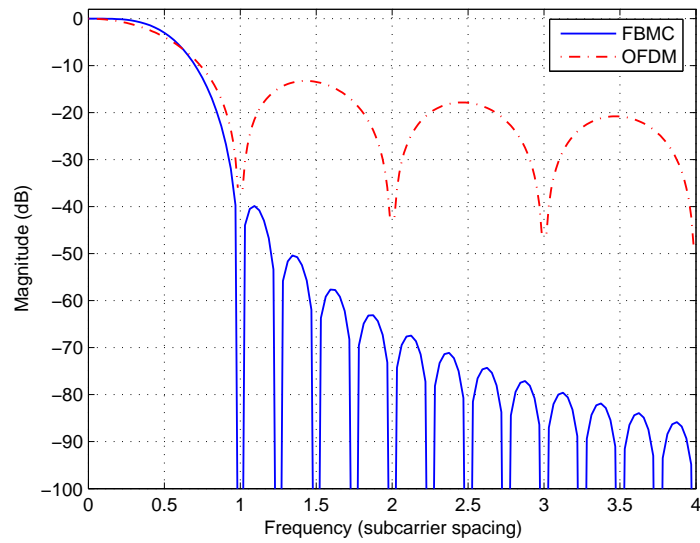
spectrum efficiency. Brandes et al. proposed a method to reduce the sidelobes by assigning non-zero values to the deactivated subcarriers in order to combine destructively with sidelobes of the transmitted data on the other subcarriers [75]. Similar concept is used by Cosovic et al. in [76] by applying weighting factors to the active subcarriers. The achieved sidelobe reduction in [75] and [76] is around 20 dB and 10 dB respectively. Note that no additional canceling subcarriers are used in [76]. Cosovic et al in [77,78] developed a multiple-choice sequence (MCS) method to obtain a 10 dB reduction. The method maps the transmitted symbol sequence to a set of sequencing in order to choose the sequence with the lowest side lobe.

In [79], a sidelobe reduction technique consists of a dual application of the constellation expansion and subcarrier cancelation. The low order constellations are mapped to subset of points in higher order constellation using the constellation expansion. Afterwards, the mapping that offer the lowest sidelobes is chosen where 16 dB sidelobe suppression is achieved using this technique.

Xu and Chen in [80] perform a data precoding before the IFFT at the transmitter. A complex optimization task is required to obtain the coding matrix at every time the configuration of the active channels varies. This method requires the addition of the precoding overhead and achieves around 20 dB sidelobe reduction.

### **2.2.2 Filter Bank Multicarrier (FBMC) system**

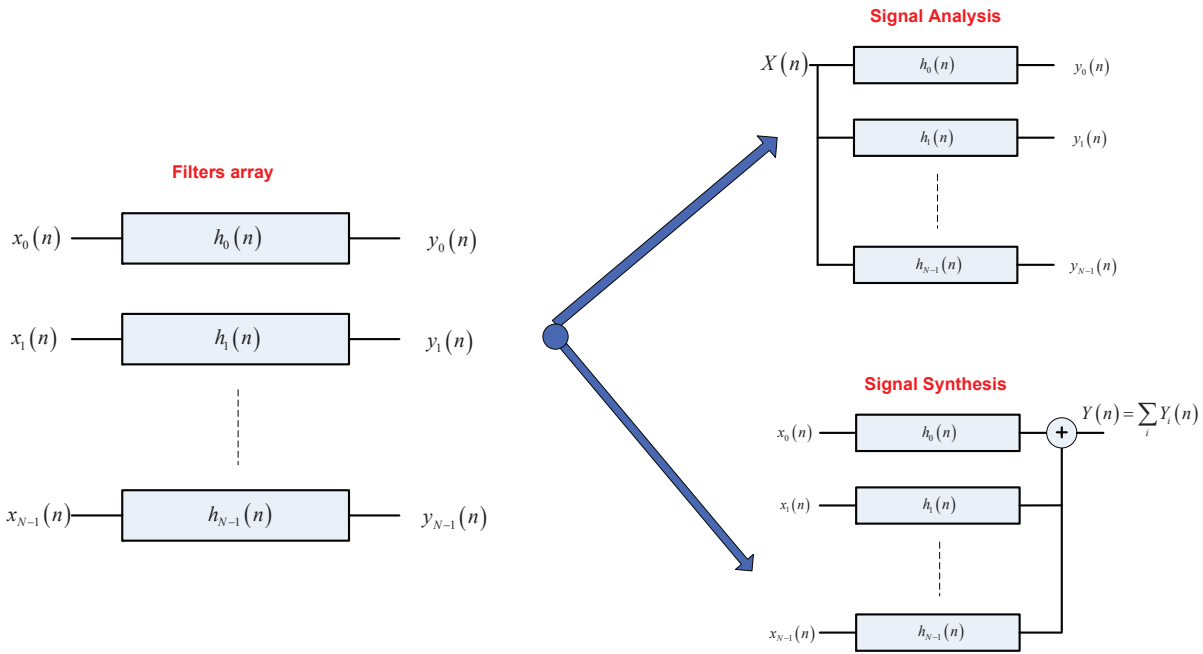
FBMC system can be considered as alternative solution to overcome the OFDM shortcomings by the addition of generalized symbol shaping filters. As discussed formerly, OFDM system uses CP to cope with the multiple path channel which reduces the effective throughput of the system in addition to the power wasting in the transmission of the CP part. Besides, the high spectral leakage of OFDM causes interference to the unsynchronized signal in the adjacent bands. These problems are addressed in FBMC by using a well designed shaping filters which produces a well localized subchannel in both time and frequency domain. Accordingly, FBMC systems have more spectral containment signals and provide more efficient use of the radio resources where no CP is needed. The spectra of OFDM and FBMC subcarriers are plotted in Fig. 2.11. The OFDM signal has larger sidelobes than the FBMC one. The first sidelobe in OFDM is 13 dB below the mainlobe. In FBMC, the first sidelobe is 40 dB below the mainlobe and the filter attenuation exceeds 60 dB for the frequency range above two subchannel spacings.



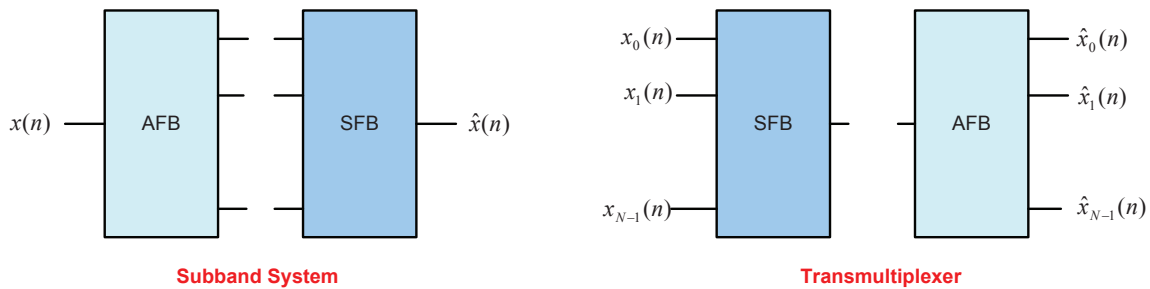
**Figure 2.11:** Frequency response of OFDM and FBMC filters [81].

Filter bank can be defined generally as an array of  $N$  filters that processes  $N$  (different or equal) input signals to produce  $N$  outputs as depicted in Fig. 2.12. If the inputs of these  $N$  filters are connected together, the system -in analogous manner- can be seen as analyzer to the the input signal based on each filter characteristics. Therefore, this type of filter bank is called analysis filter bank (AFB). On the other hand, by adding the outputs of the filter array, a new signal is synthesized and hence this type of filter bank is called synthesis filter bank (SFB) [82]. Note that any single output of the analysis filters represents a portion of the signal spectrum in the subband processing where further processing can be performed on it. To reduce the number of operation without missing the original data, the downsampling (decimation) can be used where the Nyquist-Sahnnon sampling theory should be fulfilled [83, 84]. Alternatively, by the upsampling (interpolation) of the inputs of the SFB, the signal can occupy the desired spectral region. Filter bank with different sampling rates are called multirate filter bank [85–89].

Depending on the AFB and SFB arrangement, two different systems are obtained as described in Fig. 2.13. In the analysis-synthesis configuration, a subband system is constructed. Audio/image compression system where subband signals are coded depending on their energies is an example of this system. Moreover, the single tap equalizer whereby the the different subbands of the signals are amplified differently according to the channel is using this type of configuration. Conversely, the synthesis-analysis configuration is called transmultiplexer and is applied in the multicarrier communication systems [86].



**Figure 2.12:** General filter bank structure.



**Figure 2.13:** AFB and SFB different arrangements.

When the system is designed so that the output is a time-delayed version of the input, i.e. no error in the output, the filter bank is called perfect reconstruction (PR) filter bank. Systems with limited aliasing or distortion are called near perfect reconstruction (NPR) filter bank [85, 86, 90].

The FBMC systems are classified into three main methods: offset quadrature amplitude modulated OFDM (OQAM-OFDM), cosine-modulated multitone (CMT) and filtered multitone (FMT). OQAM-OFDM was first proposed by Chang [91] in the mid 1960's and decoupled by Salzberg in [69]. The basic idea is to introduce a half symbol delay between the inphase and the quadrature components of the quadrature amplitude modulation (QAM) symbols. The discrete time implementation of the OQAM-OFDM is developed in [92]. Thereafter, Hirosaki in [93] developed an efficient polyphase discrete Fourier transform (DFT) structure for the im-

plementation of Salzberg's method. The isotropic orthogonal transfer algorithm (IOTA) has been presented in [94, 95] in order to adapt the FBMC system to match the channel time and frequency dispersion. See [96, 97] for further discussion about IOTA design.

The adjacent bands in OQAM-OFDM overlap among each other where the subcarrier bands are spaced by the symbol rate. The time staggering in addition to the well designed filters ensures the orthogonality between the adjacent subcarriers and guarantee the reception of the symbols free of ISI and inter carrier interference (ICI). OQAM-OFDM is adopted in TIA digital radio technical standards [98], which is the only radio transmission standard that uses FBMC [99]. Extended analysis and design issues can be found in [100–102]. In CMT, the subcarriers carry a sequence of pulse amplitude modulation (PAM) symbols and are modulated using the vestigial sideband (VSB) modulation. With the same symbol duration and number of subchannels, CMT uses half of the bandwidth used by OQAM-OFDM [103]. CMT is considered by the under-development IEEE P1901 standard for power line communication (PLC) systems [99]. Further details on CMT can be found in [104–106]. Different from OQAM-OFDM and CMT systems, FMT does not allow the subcarrier overlapping. To allow the transition between bands, guard bands are inserted. Therefore, FMT has the least bandwidth efficiency among the different FBMC types [103].

### **FBMC for Cognitive Radio**

The advantages of adopting FBMC systems in CR scenarios were discussed by Amini et al. in [103] and by Farhang-Boroujeny et al. in [107]. The FMT, CMT and OQAM-OFDM methods are compared in terms of the spectral efficiency. The spectral efficiency of FBMC is found to be higher than that of OFDM. The authors discuss that FMT has the simplest implementation but suffers from low spectral efficiency. Moreover, CMT offers the best frequency selectivity and has the capability of blind detection. Additionally, the authors states that OFDM-OQAM signal is the best suitable method for CR scenario since it achieves the highest stopband attenuation among the three methods which means lower interference to the adjacent bands and accurate spectrum sensing results. Farhang-Boroujeny in [108] proposed a filter bank multi-tapper based spectrum sensing method. The spectrum sensing is performed by measuring the signal powers at the outputs of the subcarrier channels at the receiver. Therefore, the spectrum sensing is performed at virtually no computational cost by reusing of the FBMC receiver.

In [109], Zhang et al. studied the spectral efficiency of OQAM-OFDM CR systems as well as the induced interference to the PU. Different OQAM-OFDM prototype filters are compared and the authors states that SUs with OQAM-OFDM physical layer achieve more throughput than those with OFDM or windowed OFDM ones. Afterwards, zhang et al. in [110] proposed a resource allocation algorithm in the uplink OQAM-OFDM based CR systems. They showed that the achieved capacity of the OQAM-OFDM system is higher than that of the OFDM system.

Ihalainen et al. in [111] addressed the reappearing PU detection problem during the ongoing secondary transmission. An energy based spectrum sensing technique is used. The high frequency containment of the OQAM-OFDM waveform is exploited to construct continuous silent subbands within the transmission band for spectrum monitoring. The authors suggest to distribute a reappeared PU detected message over the monitoring subbands to alarm SUs for quick channel vacation.

Due to the preference of using OQAM-OFDM<sup>1</sup> in the CR systems, the system structure is described next in detail.

### 2.2.3 Structure and Implementation of OQAM-OFDM

Each subcarrier in the OQAM-OFDM system is modulated with a staggered QAM as described previously. The basic idea is to transmit real-valued symbols instead of transmitting complex-valued ones. Due to this time staggering of the in-phase and quadrature components of the symbols, orthogonality is achieved between adjacent subcarriers. The modulator and the demodulator are implemented using the synthesis and analysis filter banks. The filters in SFB are AFB are obtained by frequency shifts of a single prototype filter. Figure 2.14 depicts the structure of the synthesis and analysis filter banks at the transmitter and receiver in OQAM-OFDM systems. The different blocks of this structure can be described as follows

1. **OQAM modulation:** the  $n^{\text{th}}$  QAM symbol at the  $k^{\text{th}}$  subcarrier can be expressed as  $Sym_k(n) = a_k(n) + jb_k(n)$ , where  $a_k(n)$  and  $b_k(n)$  are the real and imaginary parts respectively, and  $k = 0, \dots, N - 1$ . The inputs to SFB  $InSFB_k(n)$  are generated as

---

<sup>1</sup>In the next chapters, FBMC refers to OQAM-OFDM structure.

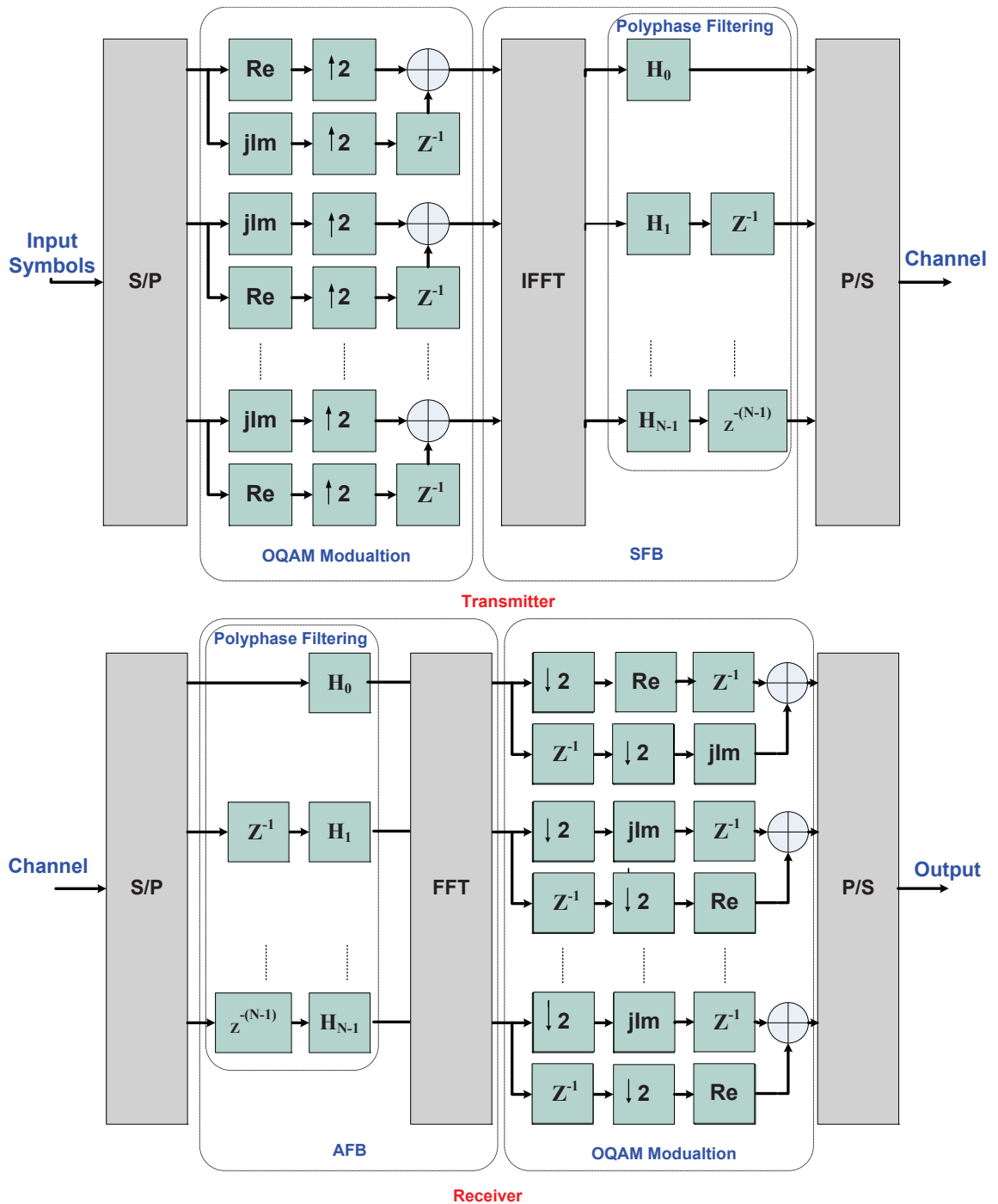
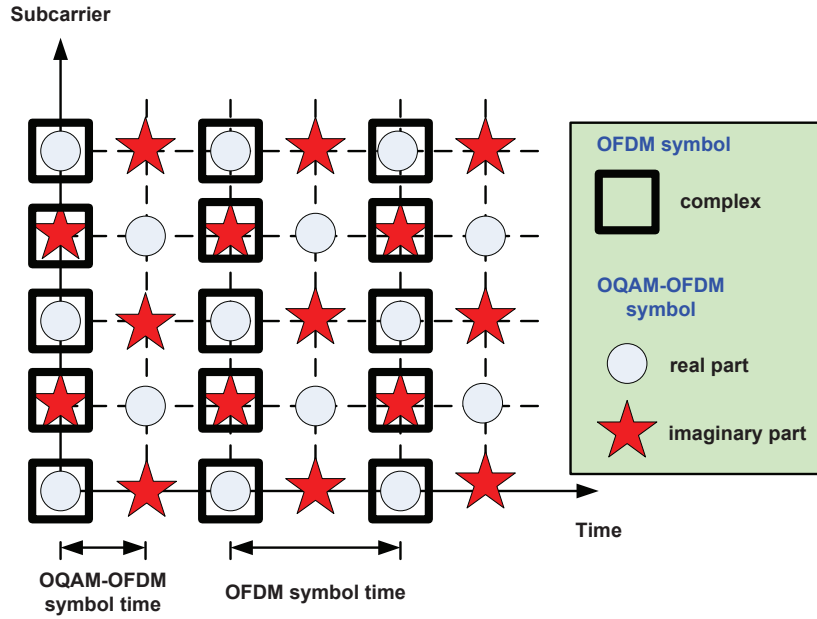


Figure 2.14: OQAM-OFDM system's transmitter and receiver.



**Figure 2.15:** Symbols distribution in time/subcarrier plan for OQAM-OFDM and OFDM systems.

follows

$$\begin{aligned} \text{InSFB}_k(2n) &= \begin{cases} a_k(n), & k \text{ even} \\ jb_k(n), & k \text{ odd} \end{cases}, \\ \text{InSFB}_k(2n+1) &= \begin{cases} jb_k(n), & k \text{ even} \\ a_k(n), & k \text{ odd} \end{cases} \end{aligned} \quad (2.6)$$

A mapping example using OQAM is plotted in Fig. 2.15. The grid showed the mapping of the real and imaginary parts of the different subcarrier at different time symbols [112].

2. **SFB:** the OQAM modulated symbols are filtered using SFB. In SFB, as well as the AFB, the filters are obtained by frequency shifts of single low pass prototype filter. The use of polyphase structure leads to efficient implementation. The input and output relation for a given FIR filter can be written as

$$y(k) = \sum_{i=0}^{L-1} h_i x(k-i) \quad (2.7)$$

where  $L$  is the number of filter coefficients. Therefore, the corresponding Z-transform function is

$$H(z) = \sum_{i=0}^{L-1} h_i z^{-i} \quad (2.8)$$

If the target is constructing N-bands filter bank where the center frequency of each band is  $\frac{2\pi i}{N}$ , the transfer function of the  $n^{th}$  band in the transmitter side can be expressed as

$$E_n(z) = \sum_{i=0}^{L-1} h_i z^{-i} W^{ni} \quad (2.9)$$

where  $W = e^{-j2\pi/N}$ . Letting  $L = KN$ , (2.9) becomes

$$E_n(z) = \sum_{i=0}^{KN-1} h_i z^{-i} W^{ni} = \sum_{n=0}^{N-1} z^{-l} H_n(z^N) \quad (2.10)$$

where

$$H_n(z^N) = \sum_{k=0}^{K-1} h_{kN+n} (z^{-Nk}) \quad (2.11)$$

Considering all the different filters with  $1/N$  frequency shifts, SFB operation can be represented in a matrix form as follows

$$\begin{bmatrix} E_0(z) \\ E_1(z) \\ \cdot \\ \cdot \\ E_{N-1}(z) \end{bmatrix} = \begin{bmatrix} 1 & 1 & \cdot & \cdot & 1 \\ 1 & W^{-1} & \cdot & \cdot & W^{-N+1} \\ \cdot & \cdot & \cdot & \cdot & \cdot \\ \cdot & \cdot & \cdot & \cdot & \cdot \\ 1 & W^{-N+1} & \cdot & \cdot & W^{-(N-1)^2} \end{bmatrix} \begin{bmatrix} H_0(z^N) \\ z^{-1}H_1(z^N) \\ \cdot \\ \cdot \\ z^{-(N-1)}H_{N-1}(z^N) \end{bmatrix} \quad (2.12)$$

Note that the square matrix is the IDFT matrix of order  $N$  and every subcarrier input is occupying the subchannel with the center frequency  $1/N$  filtered with a filter with frequency response shifted by  $1/N$  as well.

3. **AFB**: is the first part in the receiver side. Its function is producing output signals with spectrum centered in the zero frequency. Therefore, at each subcarrier, the input is shifted by  $1/N$  on the frequency axis and then filtered using the low pas prototype filter. By a similar analysis to that used in SFB, the matrix form representation of the AFB is as follows

$$\begin{bmatrix} E_0(z) \\ E_1(z) \\ \cdot \\ \cdot \\ E_{N-1}(z) \end{bmatrix} = \begin{bmatrix} 1 & 1 & \cdot & \cdot & 1 \\ 1 & W^1 & \cdot & \cdot & W^{N-1} \\ \cdot & \cdot & \cdot & \cdot & \cdot \\ \cdot & \cdot & \cdot & \cdot & \cdot \\ 1 & W^{N-1} & \cdot & \cdot & W^{(N-1)^2} \end{bmatrix} \begin{bmatrix} H_0(z^N) \\ z^{-1}H_1(z^N) \\ \cdot \\ \cdot \\ z^{-(N-1)}H_{N-1}(z^N) \end{bmatrix} \quad (2.13)$$

The square matrix here represents the DFT matrix of order  $N$ .



4. **OQAM demodulation:** in this part, the original QAM symbols are reconstructed from the OQAM symbols received at the  $k^{\text{th}}$  subcarrier according to the following rule

$$\text{SymOut}_k(n) = \begin{cases} \text{Re}[\text{OutAFB}_k(2n)] + j\text{Im}[\text{OutAFB}_k(2n+1)], & k \text{ even} \\ j\text{Im}[\text{OutAFB}_k(2n)] + \text{Re}[\text{OutAFB}_k(2n+1)], & k \text{ odd} \end{cases} \quad (2.14)$$

where  $\text{OutAFB}_k(n)$  is the output of AFB at the  $n^{\text{th}}$  symbol time on the  $k^{\text{th}}$  subcarrier.

The OQAM-OFDM baseband equivalent can be expressed mathematically as [113],

$$x(n) = \sum_k \sum_{l \in \mathbb{Z}} a_{k,l} h(n - w\tau_o) e^{j2\pi \frac{k}{N}n} e^{j\phi_{k,l}} \quad (2.15)$$

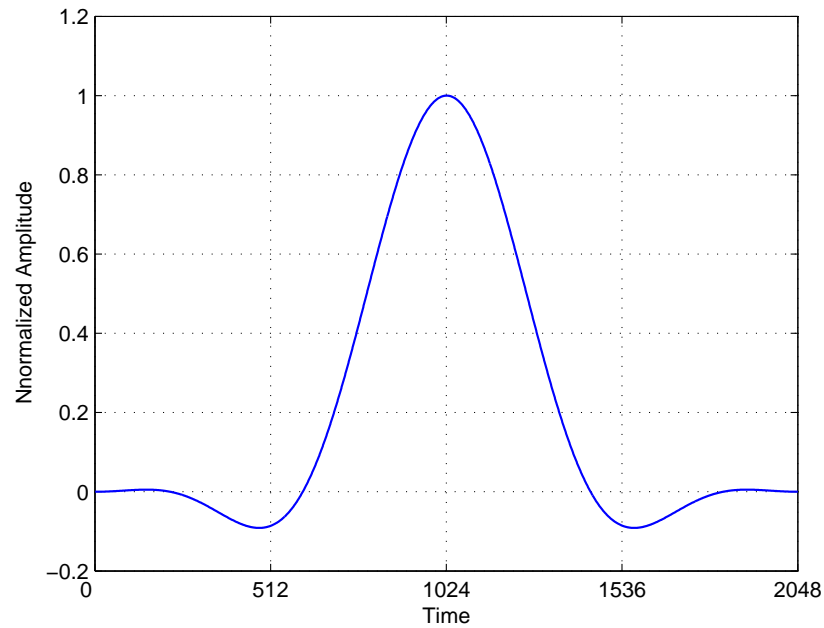
where  $\{k\}$  is the set of subcarrier indices,  $\phi_{k,l} = \frac{\pi}{2}(k+l) - \pi kn$  is an additional phase term represents the OQAM modulation and  $\tau_o$  is OQAM-OFDM symbol duration.  $a_{k,l}$  are the real symbols obtained from the complex QAM symbols and  $h(n)$  is the prototype filter. The prototype filter is designed depending on the application. As described in [114], in order to have a perfect recovery in an ideal noiseless channel, the prototype filters in SFB and AFB should be real filters, with a frequency response bandlimited within  $[-F, F]$  with  $F = \frac{1}{2\tau_o}$ , and half-Nyquist, i.e. the multiplication of the frequency responses of the SFB and AFB filters must satisfy the Nyquist criterion. Throughout this dissertation, the prototype filter considered in the European Project "PHYDYAS -physical layer for dynamic spectrum access and cognitive radio-" is used [81, 102]. Accordingly, by assuming an overlapping factor of  $K = 4$  and  $N$  subcarriers, the  $L = KN$  filter coefficients can be obtained as follows

$$h(0) = 0, h(n) = 1 + 2 \sum_{k=1}^{K-1} (-1)^k H\left(\frac{k}{L}\right) \cos\left(\frac{2\pi kn}{L}\right); 1 \leq n \leq L-1 \quad (2.16)$$

where  $H\left(\frac{k}{L}\right)$  are the desired  $L$  values in the frequency domain which are given by

$$\begin{aligned} H(0) &= 1 \\ H\left(\frac{1}{L}\right) &= 0.971960 \\ H\left(\frac{2}{L}\right) &= \frac{1}{\sqrt{2}} \\ H\left(\frac{3}{L}\right) &= \sqrt{1 - H^2\left(\frac{1}{L}\right)} = 0.235147 \\ H\left(\frac{k}{L}\right) &= 0; 4 \leq k \leq L-1 \end{aligned} \quad (2.17)$$

Fig. 2.16 plots the impulse response of the PHYDYAS prototype filter with overlapping factor  $K = 4$  and  $N = 512$  subcarriers. Fig. 2.17 plots the frequency response of the OFDM and



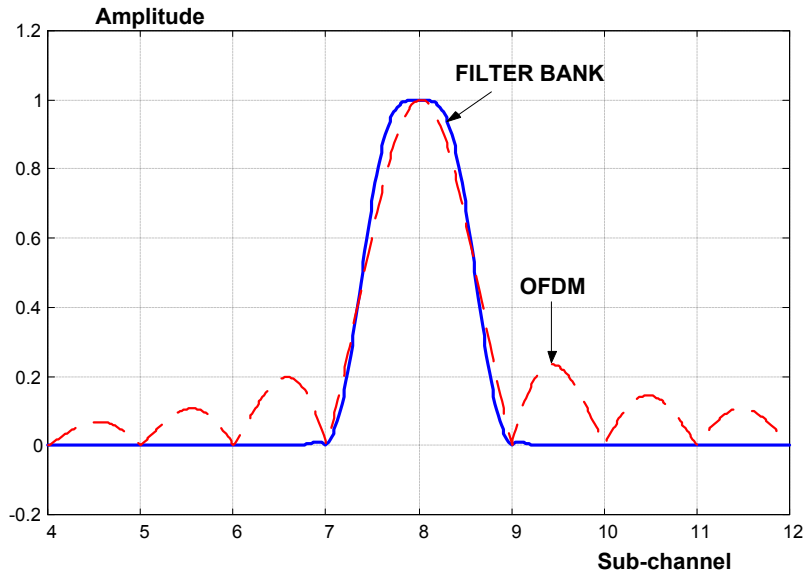
**Figure 2.16:** PHYDYAS filter impulse response.

the PHYDYAS prototype filters. It can be noted that the OQAM-OFDM system has very small side lobes in comparison with that of the OFDM system. Note that the OFDM system is a special case of the FBMC which can be generated by setting the filter coefficients equal to one, i.e. rectangular pulse shape.

### 2.2.4 Non Orthogonal Frequency Division Multiplexing (NOFDM) Systems

The non-orthogonal multicarrier modulation was first proposed in [115] as an approach for multicarrier transmission over doubly dispersive channels. In doubly dispersive channels, the transmission is affected by both the time dispersion due to the multipath propagation and by the frequency dispersion due to the doppler shift caused by the mobility of the terminals. NOFDM is a generalized multicarrier (GMC) framework where FBMC and OFDM systems are considered as special cases. The basic differences can be summarized as follows

- In OFDM and FBMC systems, the shaping pulses are designed to be orthogonal which is not the case in NOFDM. Note that the orthogonal basis functions are optimum basis in additive white Gaussian noise (AWGN) channels but not in the doubly dispersive



**Figure 2.17:** OFDM and PHYDYAS filters frequency responses.

channels.

- The signals in NOFDM can overlap each other in time and frequency (TF) domain as given in Fig. 2.18 where every circle - also referred to as atom- denotes the TF representation of the pulse. This overlapping reduces the distances between the pulses and allows more denser TF grid which leads to higher spectral efficiency.

The discrete-time representation of NOFDM signal is the Gabor discrete signal expansion and can be expressed as [115–119]

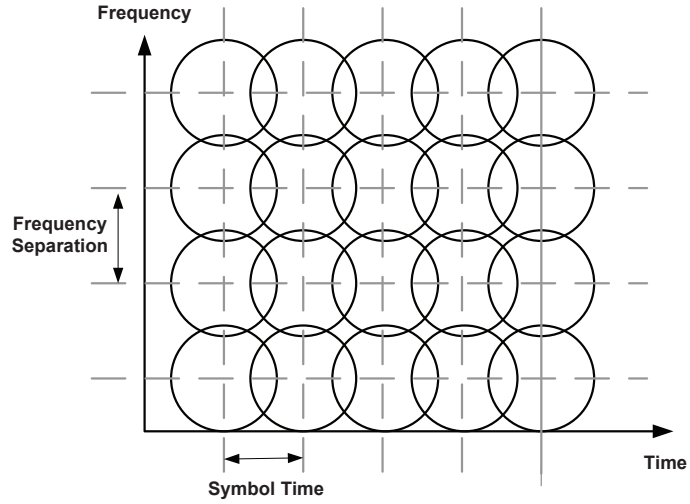
$$s[k] = \sum_{n \in \mathbb{Z}} \sum_{m=0}^{M-1} c_{n,m} g_{m,n}[k] \quad (2.18)$$

where  $M$  is total number of subcarriers,  $c_{n,m}$  is the frame coefficients,  $\mathbb{Z}$  is the set of integers, and  $\{g_{m,n}[k]\}$  is the sequence of basis function (Gabor atoms) and defined as

$$g_{m,n}[k] = g[k - nN] e^{j2\pi m(k-nN)/M} \quad (2.19)$$

where  $N$  is the symbol time and  $g[k]$  is the pulse shape. The sequence  $\{g_{m,n}[k]\}$  form the frame if the frame condition holds [118, 120, 121]. The frame condition is satisfied if there exists two real constants  $0 < A \leq B < \infty$ , referred to as frame bounds, such that

$$A \|s[k]\|^2 \leq |\langle s[k], g_{m,n}[k] \rangle| \leq B \|s[k]\|^2 \quad (2.20)$$



**Figure 2.18:** Time-Frequency representation of NOFDM transmission frame.

where  $\langle \cdot, \cdot \rangle$  denotes the inner product. A necessary condition for the sequence  $\{g_{m,n}[k]\}$  to complete a Gabor frame is that  $N \leq M$  which means that  $\{g_{m,n}[k]\}$  are sufficiently densely placed in the TF plane since the number of Gabor coefficient is greater than the number of signal samples, i.e. overcritical sampling. This also mean that dual Gabor frame exists [115, 117, 118, 120], i.e.  $\{\gamma_{m,n}[k]\}$ . From  $\{\gamma_{m,n}[k]\}$ , the coefficients  $\{c_{n,m}\}$  can be evaluated as

$$c_{n,m} = \sum_{k \in \mathbb{Z}} s[k] \gamma_{m,n}^*[k] \quad (2.21)$$

where

$$\gamma_{m,n}[k] = \gamma[k - nN] e^{j2\pi m(k-nN)/M} \quad (2.22)$$

and  $*$  denotes the complex conjugate.

$g[k]$  and  $\gamma[k]$  are dual real valued prototype filters (Gabor atoms) and referred to as synthesis window and analysis window respectively. Like the FBMC systems, NOFDM can be implemented efficiently using IFFT/polyphase structure and hence has higher complexity and peak-to-average power ratio (PAPR) than OFDM system at the price of good TF localization of the signals [119, 122, 123].

The prototype filters are designed according to the required application and objectives. For example, the prototype filter is deigned in order to have small sidelobes for overlay CR systems [122, 123]. Usually the design starts by determining the analysis filter as well as the number of channels. Afterwards, the dual synthesis pulse and the symbol time are derived. Various algorithms were developed to drive the dual prototype filters. The simplest but not

efficient one is the design in order to achieve biorthogonality between the pulses as described in [86, 124]. The least square error (LSE) can be used to design the dual pulses to be as similar as possible as given in [125, 126]. Low complexity algorithm is presented in [127] while other techniques can be found in [128, 129].

The use of NOFDM systems in CR systems is discussed in [118, 123]. The authors states that there exists a tradeoff between the high out of band interference in the OFDM systems and the higher implementation complexity and PAPR in NOFDM system. The authors suggests the development of an application-based analysis tool that can help in dealing with tradeoff during the decision-making process in the CR systems.

### 2.2.5 Summary of OFDM and FBMC Differences

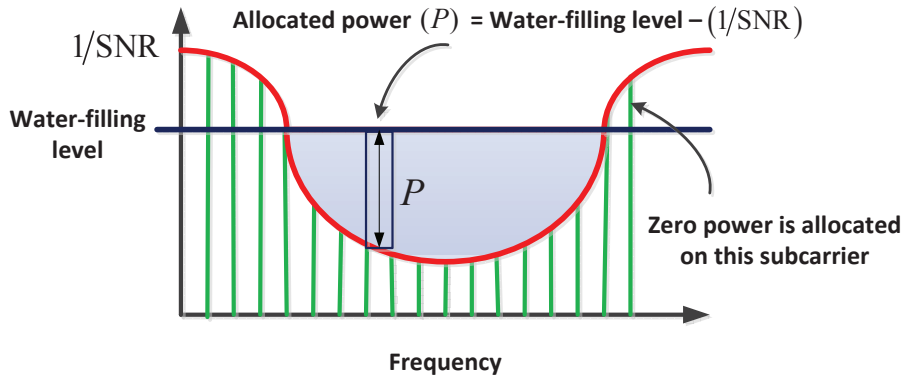
The main differences (advantgaes/disadvantages) between OFDM and FBMC systems can be summarized in the following points

- **CP extension:** unlike the FBMC, OFDM requires the addition of the CP in order to mitigate the effect of the multipath channel and avoid ISI. This addition reduces the OFDM bandwidth efficiency. However, the CP extension makes OFDM more robust to the timing-phase error, i.e. a phase rotation in the frequency domain, since it allows some variation of the timing phase [99].
- **Sidelobes:** OFDM systems suffers from the large sidelobes of the frequency response of its rectangular filters which causes high interference to the unsynchronized signals. The low sidelobes of FBMC makes it more attractive for CR overlay systems.
- **Synchronization:** the OFDM signals should arrive the receiver with perfect saucerization in order to be detected correctly. This is can be performed easily by the BS in downlink. In uplink, synchronizing the transmission signals from different users is not a trivial task and might be not possible. Therefore, additional processing techniques like the multiple access interference (MAI) cancelation should be performed in the receiver. In FBMC, MAI is suppressed mostly without any additional processing due to the excellent frequency localization of the subcarriers.
- **Doppler effect:** OFDM has high sensitively to the frequency offset than FBMC. Therefore, FBMC performs significantly better with the increase of the user mobility.

- **Multiple input multiple output (MIMO) systems:** the extension of OFDM to work with MIMO systems is straightforward but its not simple in FBMC. This is due to the interference introduced in time and frequency to a given symbol by the surrounding ones. Some limited work on MIMO-FBMC systems can be found in [130–133].
- **Spectrum sensing:** in both OFDM and FBMC, the spectrum sensing can be performed with no additional cost using the existing system components. However, the spectral leakage in OFDM signals degrades the performance of the spectrum sensing. Much larger dynamic range can be exploited in FBMC systems and high spectrum sensing resolution can be achieved.
- **Equalization:** in OFDM, single-tap equalizer is used with the flat gain channels when the length of CP is more than the channel impulse response as well as when the channel is constant over each subcarrier during the transmitting time. This flat gain assumption is approximately correct in FBMC when sufficiently large number of subcarriers is used.
- **Computational Complexity:** as shown in Fig. 2.7 and Fig. 2.14, the general structure of OFDM and FBMC is quite similar where the FFT block is common in both of them and the CP insertion/removing block in OFDM is replaced by the polyphase network in FBMC which requires more computational complexity. However, using of filtering or any other technique to solve the large sidelobes or synchronization problems in OFDM make the computational complexity of FBMC moderately higher than that of OFDM.

## 2.3 Resource Management in Multicarrier Systems

The distribution of the available resources is a fundamental aspect in the multicarrier systems. The target is to allocate the power and frequency spectrum as well as select the appropriate modulation type so that the system performance is maximized and the required quality of services is achieved. In this section, a general overview of the resource management in multicarrier systems is presented. Detailed review of the previous work in non-cognitive and cognitive systems is postponed to the next chapters.

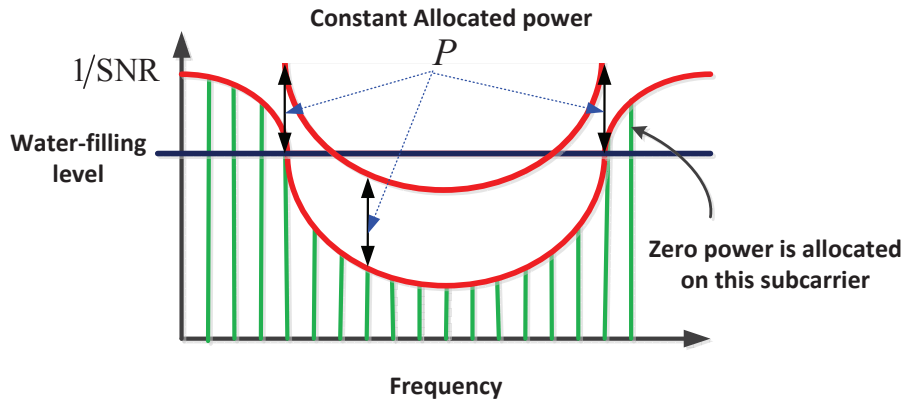


**Figure 2.19:** Description of the water-filling principle.  $1/\text{SNR}$  denotes the inverse of the subcarriers signal to noise ratio.

### 2.3.1 Resource Allocation in Single User Multicarrier systems

Two categories of problems are considered for optimization in single user multicarrier systems. The first is the *rate maximization problem* (RM) where the objective is to maximize the total data rate under a given power budget constraint. The other problem is called *margin maximization problem* (MM) where the objective is maximizing the achievable system margin by minimizing the transmit powers subject to rate constraint. In [134], the duality between rate and margin maximization problems is proved which means that the optimal solution for one yields to the optimal solution for the other. The optimal power and bit allocation in single user multicarrier systems (also called point to point systems) can be achieved by applying the *water-filling* (also called *water-pouring*) solution in which a large amount of power is loaded on the subcarriers with low attenuation compared with the others [135]. The water-filling principle is described in Fig. 2.19. As we can see, zero power is allocated to the subcarriers with high attenuation.

The water-filing algorithm in the single user systems has several variants. In *statistical water-filling* [136], the maximum capacity is achieved by performing the water-filling over time when the channel statistics are known. *Constant power water-filling* [137] simplifies the transmitter design by allocating zero power to the subchannels with zero power in the exact water-filling, while allocates constant power in the rest of the subchannels with positive power in the exact water-filling as described in Fig. 2.20. *Mercury water-filling* is proposed in [138] to deal with limitation introduced by having a discrete constellation. The signal to noise ration (SNR) gap is introduce to quantify the gap between the capacity practical system

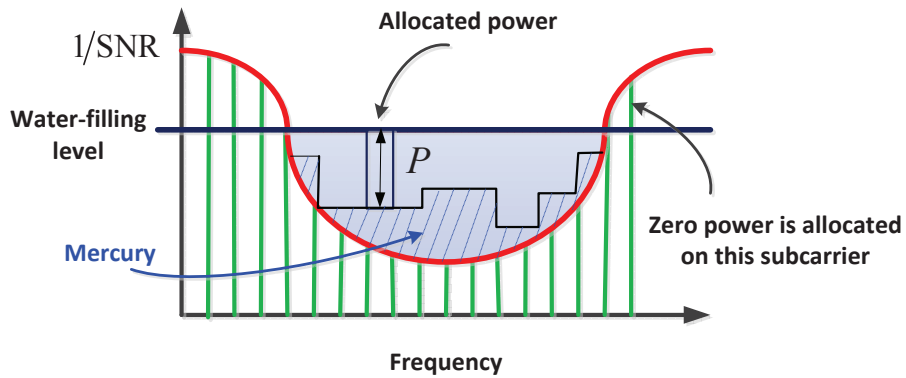


**Figure 2.20:** Description of the constant water-filling principle.

and the Shannon theoretical capacity. As depicted in Fig. 2.21, a mercury layer is poured over the subcarriers before the water. Each subchannel has different mercury height from the others to fit to the loaded constellation. Note that, like the conventional water-filling, the allocated power at each subchannel is the height to the water-filling level.

### 2.3.2 Resource Allocation in Multi-user Multicarrier systems

In multiple user multicarrier systems, the users transmissions/receptions may undergo variant fading attenuations due to the different locations of every user. This is called multi-user diversity. To benefit from this diversity, adequate resource allocation should be performed to achieve the maximum performance. Therefore, the allocation process includes not only power (bit) allocation like the single user case but also the subcarrier (frequency) allocation where a disjoint set of subcarriers should be allocated to each user. The disjoint set of subcarriers con-



**Figure 2.21:** Description of the mercury water-filling principle.



straint makes the problem not convex where the complexity of obtaining the optimal solution grows exponentially with the number of subchannels. In order to reduce the high complexity of obtaining the optimal solution, two different approaches are used: either to use a sub-optimal approach, like the allowing the subcarrier sharing, to solve the original joint optimization problem or split the original problem into two sub-problems; one for the frequency allocation and another for power allocation.

The addressed problems in multiuser multicarrier systems can be categorized in three different types [139]. The first is *Multi-user raw rate maximization* where the total sum-rate of all users is maximized subject to the total/individual power and disjoint subcarrier allocation constraints. This way of maximization suffers from the limited achieved fairness between users since the users located close to the transmitter/receiver, i.e. users with good channel, are allocated with more subcarriers than the distant ones, and in order to enhance the system fairness, the *rate adaptive optimization* approach is used by maximizing the rate of the weakest user subject to the powers and disjoint subcarrier allocation constraints. This *max-min fairness* is not well suited to scenarios with users require different rates corresponding to different service levels. Therefore, a non-linear *proportional fairness* constraints on the rate are imposed to guarantee probational rates among the different users as given in [140]. The third approach is the *margin adaptive optimization* where the transmit powers are reduced subject to per-user rate constraints. The *hard fairness* constraint might be added to force the users to have the same rate at each channel realization. To consider the trade-off between the different optimization parameters like spectral efficiency, fairness and quality of service (QoS), the utility function is used to map the resource use as well as the performance criteria into a price value and hence, utility-based resource allocation and scheduling algorithms are developed [141]. Besides, MIMO systems are capable of exploiting both transmitter and receiver diversity. By combining MIMO technology with multi-user multicarrier systems, the transmission rate, range and reliability are improved [142]. The trade-off between the different gains in the MIMO systems, i.e. diversity gain, multiplexing gain, and multiple-access gain, is studied in [143]. Many algorithms have been developed for the resource allocation in multicarrier systems with MIMO capability (see e.g. [144, 145] and references therein).

The research on resource allocation in multi-cell multicarrier networks has attracted many effort. The most common way to avoid the inter-cell interference is by applying what is called the frequency reuse. By the frequency reuse, each cell uses frequency bands different from that

used in the adjacent cells. The number of different channels between cells is called the reuse factor. By careful selection of the reuse factor value as well as the BSs locations, the interference between cell might be neglected or modeled as a noise. Accordingly, the algorithms developed to solve the resource allocation problem in single-cell scenarios can be adopted in the multi-cell scenario. The fixed reuse factor is developed in [146, 147] to be fractional, whereby the full band is assigned to users in the internal part of the cell while the frequency reuse is adopted at the edges of the cells. Moreover, random reuse factor based on the actual channel conditions is proposed in [148], where a given subcarrier is allocated to a certain BS if the overall capacity of the system will be increased. The dynamic frequency reuse improve the performance significantly with respect to the fixed frequency reuse scheme.

## 2.4 Constrained Optimization

The design of the communication system in order to achieve a given objective (maximize/minimize a cost function) subject to various resource constraints is an essential task. This type of problems is called constrained optimization which often appears in the multicarrier systems. Consider the optimization problem in the form

$$\begin{aligned} \max_{\mathbf{x}} \quad & f_0(\mathbf{x}) \\ \text{s.t.} \quad & f_i(\mathbf{x}) \leq 0; \quad i = 1, \dots, m \end{aligned} \tag{2.23}$$

where  $\mathbf{x} = [x_1, \dots, x_n]$  is the optimization variables,  $f_0(\cdot)$  and  $f_i(\cdot), i = 1, \dots, m$  are the objective function and the inequality constraints functions respectively.  $\mathbf{x}$  is called a *feasible point* if it satisfies the constraints and the union  $\mathcal{X}$  of all the feasible points is called *feasible set*.  $p^*$  is called the optimal value and referred to the value of the objective function at one of the points inside the optimal set.

If the objective and constraints functions are all linear, the problem is called linear programming (LP) and the global optimal point is easy to be found. Simplex algorithm is one of the most popular LP algorithms. Since the LP problem having a solution must have an optimal value that falls on the boundary of the feasible region, the algorithm starts with a given initial solution and moves to the neighboring vertex that best improve the objective function value. These movements are performed until obtaining the optimal point [149].

When the optimization problem is convex, the global optimal solution is equal to local op-

timal point. LP problem is a special kind the convex optimization problem. Different methods can be used to find the global optimal point. For the unconstrained convex problem, gradient and Newton's method are the known ones. Gradient method (also called gradient ascent method) moves from an initial feasible point towards the optimal value by updating iteratively the current optimization variables values in the direction of the gradient. Although the gradient method is simple and it guarantees locating the optimal point (if exists), it has slow convergence [150]. Newton's method normally converges faster than the gradient method but it requires computing the Hessian of the objective function. Newton's method is used to find the roots of the equation in one or more dimensions by approximating the objective function at a given point by a quadratic function and takes a step towards the maximum of that quadratic function.

In a constrained convex optimization problems, projected gradient algorithm, interior point method, and ellipsoid method can be applied. In projected gradient algorithm, the search direction is projected into the subspace tangent to the active constraints. Ellipsoid method generates a sequence of ellipses inside the feasible set whose volumes decreases at each iteration to enclose the maximum of the convex function. Ellipsoid method is used in low-dimensional problem due its poor performance in large ones. Interior point method is a search algorithm that adds a penalty to the objective function when the search point approaches the boundary of the feasible set. More description of this algorithm follows.

If the objective function or some of the constraints are non-linear, the optimization problem is called non-linear programming (NLP) problem. Interior point method, simulated annealing [151], and genetic algorithm [152] are widely employed to perform the global optimization of in NLP. The name of simulated annealing is inspired from the annealing process in metallurgy which consists of heating and control cooling of a material increase the size of the crystals. In simulated annealing, the current solution is replaced by a new nearby random solution generated according to pre-defined distribution. The probability by which the new solution is accepted or not depends on the difference between the objective function values and also on a global parameter called temperature. Genetic algorithms are class of evolutionary algorithms inspired by the evolution biology. It starts by constructing a population of a group of random candidate solution (called individuals). The fitness of this population is evaluated and multiple individuals are selected based on their fitness and modified to form a new population. The process is repeated until the terminating condition is met.

When the value of any of the optimization variables is restricted to be integer, the problem is called integer programming problem. In this category of problems, there are no optimality conditions that can be checked to declare that a given feasible solution is optimal. Relaxation and decomposition method is one of the ways of solving the integer programming problems. By this method, the complicated constraints are removed from the constraints set by forming a new suboptimal problem that is easier to solve. The suboptimal problem is solved repetitively until the optimal value is found [153]. The branch-and-bound method is another technique to solve the integer programming problems. This method tries to avoid the enumeration of all the possible solutions of the problem by eliminating the unfeasible or dominated solutions. The branching is used to cover the feasible region by smaller subregions while the bounding is used to exclude the solutions dominated by previous computations [149]. In the sequel, we review the related concepts that are used in the dissertation.

### 2.4.1 Lagrangian Method and Optimality Conditions

Consider the problem given by () where  $f_0(\cdot)$  and  $f_i(\cdot)$  are continuously differentiable functions but not necessarily convex or concave. Augmenting the objective function with a weighted sum of the constraint functions forms the *Lagrangian function* and can be expressed as

$$\mathcal{L}(\mathbf{x}, \lambda) = f_0(\mathbf{x}) - \sum_{i=1}^m \lambda_i f_i(\mathbf{x}) \quad (2.24)$$

where  $\lambda = [\lambda_1, \dots, \lambda_m]$  is the Lagrange multipliers vector. The Lagrangian function forms an upper bound on  $f_0(\cdot)$  within the feasible set, i.e.

$$\mathcal{L}(\mathbf{x}, \lambda) \geq f_0(\mathbf{x}) \quad \forall \mathbf{x} \in \mathcal{X} \quad (2.25)$$

Based on the Lagrangian function, the following necessary and sufficient conditions are formed to find the global maximum of the problem (2.4.1) as follows

- **Karush-Kuhn-Tucker (KKT) necessary conditions [149]:** let  $\mathbf{x}^*$  to be a local maximum of the problem (2.4.1), then there exists unique Lagrange multiplier vectors  $\lambda^* = [\lambda_1^*, \dots, \lambda_m^*]$  such that

$$\begin{aligned} \frac{\partial \mathcal{L}(\mathbf{x}^*, \lambda^*)}{\partial x_i} &= 0, \quad i = 1, \dots, n \\ \lambda_j^* &\geq 0, \quad j = 1, \dots, m \\ \lambda_j^* f_j(\mathbf{x}^*) &= 0, \quad j = 1, \dots, m \end{aligned} \quad (2.26)$$

Note that the necessary condition means that if a given point satisfies the KKT conditions, it might not be a local minimum of the problem (2.4.1).

- **General sufficient condition [149]:** if  $\mathbf{x}^*$  is a feasible point together with the Lagrange multipliers vector  $\lambda^*$  satisfies  $\lambda_j^* f_j(\mathbf{x}^*) = 0$ ,  $j = 1, \dots, m$  and maximizes the Lagrangian function  $\mathcal{L}(\mathbf{x}, \lambda^*)$  over  $\mathbf{x} \in \mathcal{X}$ , i.e.  $\mathbf{x}^* = \arg \max_{\mathbf{x} \in \mathcal{X}} \mathcal{L}(\mathbf{x}, \lambda^*)$ , then  $\mathbf{x}^*$  is a global maximum of the optimization problem (2.4.1).

If  $f_0(\cdot)$  and  $f_i(\cdot)$  are convex functions, the Lagrangian function is convex function as well and the necessary conditions become also sufficient. Therefore, the global maximum  $\mathbf{x}^*$  can be found by solving the system of equations formed by

$$\frac{\partial \mathcal{L}(\mathbf{x}^*, \lambda^*)}{\partial x_i} = 0, \quad i = 1, \dots, n \quad (2.27)$$

## 2.4.2 Interior Point Method

Although that the system of equations formed by the KKT conditions is solvable, but many times a closed form can not be obtained. Therefore, another iterative techniques might be used to find the optimal solution. Interior point method can be adopted to convert the original constrained problem to a sequence of simplified unconstrained maximization problems. A description of the *barrier method* is provided in this section as a particular interior point method.

The idea of the barrier method, also referred to as *path-following algorithm*, is to start from a point in the interior of the set  $\mathcal{S}$  defined by the inequality constraints, i.e.  $\mathcal{S} = \{\mathbf{x} \in \mathcal{X} \mid f_i(\mathbf{x}) < 0, \quad i = 1, \dots, m\}$ , and construct a barrier that prevents any optimization variable from reaching the boundary of the feasible set. The problem (2.4.1) can be rewritten as [150]

$$\max_{\mathbf{x}} f_0(\mathbf{x}) + \sum_{i=1}^m I(f_i(\mathbf{x})) \quad (2.28)$$

where  $I(f_i(\mathbf{x}))$  term causes the objective to decrease without bound as  $f_i(\mathbf{x})$  approaches zero from negative value and can be expressed as

$$I(u) = \begin{cases} 0 & u \leq 0 \\ -\infty & u > 0 \end{cases} \quad (2.29)$$

The objective function (2.28) is not differentiable. Therefore,  $I(u)$  can be approximated using the logarithmic barrier function as follows

$$\hat{I}(u) = -\frac{1}{t} \log(-u) \quad (2.30)$$

where  $t > 0$  is a parameter sets the accuracy of the approximation. Therefore, by setting that  $\phi(\mathbf{x}) = -\sum_{i=1}^m \log(-f_i(\mathbf{x}))$ , (2.28) can be expressed as

$$\max_{\mathbf{x}} t f_0(\mathbf{x}) + \phi(\mathbf{x}) \quad (2.31)$$

The vector  $\mathbf{x}^*$  evaluated at given  $t$  is called a central point and denoted by  $\mathbf{x}^*(t)$ . Moreover, the set of the central points  $\mathbf{x}^*, t > 0$  forms the central path of the problem (2.4.1). The central point  $\mathbf{x}(t)$  is  $\frac{m}{t}$  suboptimal, i.e.  $(f_0(\mathbf{x}^*(t)) - p^*) \leq \frac{m}{t}$ .

Let  $\epsilon = \frac{m}{t}$  to be the accuracy of the solution found by the barrier method, problem (2.31) can be solved directly using any unconstrained optimization technique like the Newton's method [150]. Good starting point as well as moderate accuracy, i.e.  $\epsilon$  is not too small, are required for excellent performance. However, this method does not work well for large problem. A simple extension can be made by solving the problem sequentially where each iteration commenced by evaluating the new central point starting from the previously computed central point in the last iteration. The variable  $t$  is increased in every iteration by factor  $\mu > 1$ . The algorithm terminates when  $\frac{m}{t} < \epsilon$ . The factor  $\mu$  controls the number of required iterations and practically preferred to be in the interval  $\mu \in [20, 30]$ . Finally, the initial value of  $t$  is adjusted to be approximately of the same order as  $f_0(x^{(0)}) - p^*$  or  $\mu$  times this amount where  $\mathbf{x}^{(0)}$  denotes the starting point [150].

### 2.4.3 Subgradient Method

When the objective function is nondifferentiable, the subgradient method can be used. This method is much slower than the interior point method and its performance depends on the problem scaling and conditioning. The subgradient of any function  $f$  at the point  $x$  is any vector  $g$  that satisfies the inequality

$$f(y) \geq f(x) + h^T(y - x), \quad \forall y \quad (2.32)$$

when  $f$  is differentiable,  $g$  is the gradient of  $f$  at  $x$ , i.e.  $\nabla f(x)$ .

To solve the problem (2.4.1), the algorithm performs the following update on the optimization variables  $\mathbf{x}$  at every iteration

$$\mathbf{x}^{(k+1)} = \mathbf{x}^{(k)} + \alpha_k h(\mathbf{x}^{(k)}) \quad (2.33)$$

where  $k$  denotes the iteration number,  $\alpha_k$  is the  $k^{\text{th}}$  step size, and  $h(\mathbf{x}^{(k)})$  is a subgradient of the objective function or one of constraint functions at  $\mathbf{x}^{(k)}$  and is given by [154]

$$h(\mathbf{x}^{(k)}) = \begin{cases} \partial f_0(\mathbf{x}^{(k)}) & f_i(\mathbf{x}^{(k)}) \leq 0, \quad i = 1, \dots, m \\ \partial f_j(\mathbf{x}^{(k)}) & \text{for some } j \text{ such that } f_j(\mathbf{x}^{(k)}) > 0 \end{cases} \quad (2.34)$$

where  $\partial f(x)$  denotes the set of subgradients of  $f$  at  $x$ . Therefore, from (2.34), if the current point is feasible, the objective subgradient is used while the subgradient of any violated constraint is used when the current point is infeasible.

The step size should be set before the starting of the algorithm. Many different types of step size rules like constant step size with  $\alpha_k = \alpha, \forall k$ , and diminishing step size rule. A typical example of the diminishing step size rule is  $\alpha_k = \frac{a}{\sqrt{k}}$  where  $a > 0$ .

Its worth mentioning that the iteration of the subgradient method can reduce the objective function and hence the algorithm should keep track of the best point found so far, i.e.

$$p^* = f_{best}^{(k)} = \max\{f_0(\mathbf{x}^{(k)}) \mid \mathbf{x}^{(k)} \text{ feasible}, \quad k = 1, \dots, K\} \quad (2.35)$$

#### 2.4.4 Duality

The concept of duality theory is used frequently in the communication systems. It can be used to bound a nonconvex problem, determine the stopping criteria of the algorithm, or decompose the large problem into smaller ones.

Consider the following primal problem

$$\begin{aligned} \max_x & f_0(x) \\ \text{s.t.} & h(x) \leq C \end{aligned} \quad (2.36)$$

where  $f_0(\cdot)$  and  $h(\cdot)$  are not necessarily convex or concave functions and  $C$  is a constant.  $x$  is the optimization variable and  $p^*$  is the optimal value. To construct the dual problem, we start by finding the Lagrangian function of the problem

$$\mathcal{L}(x, \lambda) = f_0(x) - \lambda(h(x) - C) \quad (2.37)$$

where  $\lambda$  is the Lagrange multiplier. The Lagrange dual function is the maximum value of the Lagrangian function and can be expressed as

$$g(x, \lambda) = \max_x \mathcal{L}(x, \lambda) \quad (2.38)$$

The Lagrange dual function gives an upper bound on the optimal value  $p^*$  of the problem (2.36) for every  $\lambda \geq 0$ . Therefore, to find the lowest upper bound, the dual problem is formed by minimizing the Lagrangian dual function as follows

$$\begin{aligned} g^* &= \min_{\lambda} g(x, \lambda) \\ \text{s.t.} \quad &\lambda > 0 \end{aligned} \quad (2.39)$$

Accordingly, the inequality  $g^* \geq p^*$  is always holds even if the original problem is not convex which called the *weak duality*. The difference  $g^* - p^* \geq 0$  is referred to as the *optimal duality gap* and it defines the gap between the optimal value of the primal problem and the lowest upper bound on it that can be obtained from the Lagrange dual function.

The *strong duality* holds if  $g^* = p^*$ , i.e. the optimal duality gap is zero. If the primal problem is convex, the strong duality usually holds. For problem (2.36), when  $f_0(\cdot)$  is concave and  $h(\cdot)$  is convex, and there exists a strictly feasible point in the constraints set, the primal and dual problems have the same solution [150].

When the primal problem is not convex, the zero duality gap cannot be assured. However, the strong duality holds for the nonconvex problems that satisfied the time sharing condition [155]. The time sharing condition can be described as follows [155]: Assume that  $x^*$  and  $y^*$  are the optimal solutions of the optimization problem (2.36) with  $C = C_x$  and  $C = C_y$  respectively. The optimization problem (2.36) satisfies the time sharing condition if for any  $C = C_x, C = C_y$  and for any  $0 \leq \theta \leq 1$ , there always exists a feasible solution  $z$ , such that  $h(z) \leq \theta C_x + (1 - \theta) C_y$  and  $f(z) \geq \theta f(x) + (1 - \theta) f(y)$ .

The time sharing implies that the maximum value of the optimization problem is a concave function of  $C$ . Therefore, if the primal problem satisfies the time sharing condition and there exists a strictly feasible solution in the constraints set, the strong duality holds regardless of the convexity of the problem. This condition is usually satisfied for the optimization problems appear in the multicarrier systems in the limit as the number of subcarriers goes to infinity.

Remark that the dual problem is always convex and the subgradient method is usually used to find its solution since it is not always continuously differentiable. Eventually, if the strong



duality holds, the dual problem can be solved instead of the primal one when its easier to be solved or when a closed form solution can be found.

## Bibliography

- [1] National Telecommunications and Information Administration (NTIA), “FCC Frequency Allocation Chart,” 2003. Available at: [www.ntia.doc.gov/osmhome/allochrt.pdf](http://www.ntia.doc.gov/osmhome/allochrt.pdf).
- [2] Federal Communication Commission, “Spectrum Policy Task Force,” Report of ET Docket 02-135, Nov. 2002.
- [3] I. Akyildiz, L. Won-Yeol, M.C. Vuran, and S. Mohanty, “NeXt generation/dynamic spectrum access/cognitive radio wireless networks: A survey,” *Computer Networks*, vol. 50, no. 13, pp. 2127 – 2159, 2006.
- [4] J. Mitola, III and G.Q. Maguire, Jr., “Cognitive radio: making software radios more personal,” *IEEE Personal Communications*, vol. 6, no. 4, pp. 13–18, Aug 1999.
- [5] S. Haykin, “Cognitive radio: brain-empowered wireless communications,” *IEEE Journal on Selected Areas in Communications*, pp. 201–220, Feb. 2005.
- [6] Joseph Mitola, *Software Radio Architecture: Object-Oriented Approaches to Wireless Systems Engineering*, Wiley-Interscience, 2000.
- [7] F. K. Jondral, “Software-defined radio: basics and evolution to cognitive radio,” *Eurasip Journal on Wireless Communications and Networking*, vol. 2005, pp. 275–283, August 2005.
- [8] Ekram Hossain, Dusit Niyato, and Zhu Han, *Dynamic Spectrum Access and Management in Cognitive Radio Networks*, Cambridge University Press, New York, NY, USA, 1st edition, 2009.
- [9] G. Ganesan and Ye Li, “Cooperative spectrum sensing in cognitive radio, part I: Two user networks,” *IEEE Transactions on Wireless Communications*, vol. 6, no. 6, pp. 2204 –2213, June 2007.
- [10] G. Ganesan and Li Ye, “Cooperative spectrum sensing in cognitive radio, part II: Multiuser networks,” *IEEE Transactions on Wireless Communications*, vol. 6, no. 6, pp. 2214–2222, June 2007.

- [11] Wei Zhang and Khaled, “Cooperative spectrum sensing with transmit and relay diversity in cognitive radio networks,” *IEEE Transactions on Wireless Communications*, vol. 7, no. 12, pp. 4761–4766, December 2008.
- [12] Shengli Xie, Yi Liu, Yan Zhang, and Rong Yu, “A parallel cooperative spectrum sensing in cognitive radio networks,” *IEEE Transactions on Vehicular Technology*, vol. 59, no. 8, pp. 4079–4092, Oct. 2010.
- [13] S. Atapattu, C. Tellambura, and Hai Jiang, “Energy detection based cooperative spectrum sensing in cognitive radio networks,” *IEEE Transactions on Wireless Communications*, vol. 10, no. 4, pp. 1232–1241, April 2011.
- [14] E. Visotsky, S. Kuffner, and R. Peterson, “On collaborative detection of TV transmissions in support of dynamic spectrum sharing,” in *First IEEE International Symposium on New Frontiers in Dynamic Spectrum Access Networks (DySPAN’05)*, nov. 2005, pp. 338–345.
- [15] S.M. Mishra, A. Sahai, and R.W. Brodersen, “Cooperative sensing among cognitive radios,” in *IEEE International Conference on Communications (ICC’06)*, June 2006, vol. 4, pp. 1658–1663.
- [16] T. Yucek and H. Arslan, “A survey of spectrum sensing algorithms for cognitive radio applications,” *IEEE Communications Surveys Tutorials*, vol. 11, no. 1, pp. 116–130, First quarter 2009.
- [17] Beibei Wang and K.J.R. Liu, “Advances in cognitive radio networks: A survey,” *IEEE Journal of Selected Topics in Signal Processing*, vol. 5, no. 1, pp. 5–23, Feb. 2011.
- [18] R. Tandra and A. Sahai, “Fundamental limits on detection in low snr under noise uncertainty,” in *International Conference on Wireless Networks, Communications and Mobile Computing*, June 2005, vol. 1, pp. 464–469.
- [19] Zhi Quan, S.J. Shellhammer, Wenyi Zhang, and A.H. Sayed, “Spectrum sensing by cognitive radios at very low SNR,” in *IEEE Global Telecommunications Conference (GLOBECOM’09)*, Dec. 2009, pp. 1–6.

- [20] P.D. Sutton, K.E. Nolan, and L.E. Doyle, "Cyclostationary signatures in practical cognitive radio applications," *IEEE Journal on Selected Areas in Communications*, vol. 26, no. 1, pp. 13–24, Jan. 2008.
- [21] Kae Won Choi, Wha Sook Jeon, and Dong Geun Jeong, "Sequential detection of cyclostationary signal for cognitive radio systems," *IEEE Transactions on Wireless Communications*, vol. 8, no. 9, pp. 4480–4485, September 2009.
- [22] J. Lunden, V. Koivunen, A. Huttunen, and H.V. Poor, "Collaborative cyclostationary spectrum sensing for cognitive radio systems," *IEEE Transactions on Signal Processing*, vol. 57, no. 11, pp. 4182–4195, nov. 2009.
- [23] K.-L. Du and Wai Ho Mow, "Affordable cyclostationarity-based spectrum sensing for cognitive radio with smart antennas," *IEEE Transactions on Vehicular Technology*, vol. 59, no. 4, pp. 1877–1886, May 2010.
- [24] B. Wild and K. Ramchandran, "Detecting primary receivers for cognitive radio applications," in *First IEEE International Symposium on New Frontiers in Dynamic Spectrum Access Networks (DySPAN'05)*, nov. 2005, pp. 124–130.
- [25] M.J. Marcus, "CR: cooperative radio or confrontational radio," in *2nd IEEE International Symposium on New Frontiers in Dynamic Spectrum Access Networks (DySPAN'07)*, April 2007, pp. 208–211.
- [26] O. Sallent, J. Perez-Romero, R. Agusti, and P. Cordier, "Cognitive pilot channel enabling spectrum awareness," in *IEEE International Conference on Communications Workshops*, June 2009, pp. 1–6.
- [27] M. Filo, A. Hossain, A.R. Biswas, and R. Piesiewicz, "Cognitive pilot channel: Enabler for radio systems coexistence," in *Second International Workshop on Cognitive Radio and Advanced Spectrum Management (CogART'09)*, May 2009, pp. 17–23.
- [28] R.V. Prasad, P. Pawelczak, J.A. Hoffmeyer, and H.S. Berger, "Cognitive functionality in next generation wireless networks: standardization efforts," *IEEE Communications Magazine*, vol. 46, no. 4, pp. 72–78, April 2008.

- [29] Qing Zhao and B.M. Sadler, "A survey of dynamic spectrum access," *IEEE Signal Processing Magazine*, vol. 24, no. 3, pp. 79–89, May 2007.
- [30] Lin Xu, R. Tonjes, T. Paila, W. Hansmann, M. Frank, and M. Albrecht, "DRiVE-ing to the internet: Dynamic radio for ip services in vehicular environments," in *Proceedings of 25th Annual IEEE Conference on Local Computer Networks (LCN 2000)*, 2000, pp. 281–289.
- [31] R. Keller, T. Lohmar, R. Tonjes, and J. Thielecke, "Convergence of cellular and broadcast networks from a multi-radio perspective," *IEEE Personal Communications*, vol. 8, no. 2, pp. 51–56, Apr 2001.
- [32] P. Demestichas, G. Vivier, K. El-Khazen, and M. Theologou, "Evolution in wireless systems management concepts: from composite radio environments to reconfigurability," *IEEE Communications Magazine*, vol. 42, no. 5, pp. 90–98, May 2004.
- [33] Yiping Xing, R. Chandramouli, S. Mangold, and S.S. N, "Dynamic spectrum access in open spectrum wireless networks," *IEEE Journal on Selected Areas in Communications*, vol. 24, no. 3, pp. 626–637, March 2006.
- [34] L. Kovacs and A. Vidacs, "Interference-tolerant spatio-temporal dynamic spectrum allocation," in *2nd IEEE International Symposium on New Frontiers in Dynamic Spectrum Access Networks (DySPAN'07)*, April 2007, pp. 403–411.
- [35] D.N. Hatfield and P.J. Weiser, "Property rights in spectrum: taking the next step," in *First IEEE International Symposium on New Frontiers in Dynamic Spectrum Access Networks (DySPAN'05)*, nov. 2005, pp. 43–55.
- [36] Jon M. Peha and Sooksan Panichpapiboon, "Real-time secondary markets for spectrum," *Telecommunications Policy*, vol. 28, no. 7-8, pp. 603–618.
- [37] D. Niyato and E. Hossain, "Spectrum trading in cognitive radio networks: A market-equilibrium-based approach," *IEEE Wireless Communications*, vol. 15, no. 6, pp. 71–80, December 2008.

- [38] Yao Xie, B. Armbruster, and Yinyu Ye, “Dynamic spectrum management with the competitive market model,” *IEEE Transactions on Signal Processing*, vol. 58, no. 4, pp. 2442–2446, April 2010.
- [39] Lin Gao, Xinbing Wang, Youyun Xu, and Qian Zhang, “Spectrum trading in cognitive radio networks: A contract-theoretic modeling approach,” *IEEE Journal on Selected Areas in Communications*, vol. 29, no. 4, pp. 843–855, April 2011.
- [40] R. Berry, M.L. Honig, and R. Vohra, “Spectrum markets: motivation, challenges, and implications,” *IEEE Communications Magazine*, vol. 48, no. 11, pp. 146–155, november 2010.
- [41] W. Lehr and J. Crowcroft, “Managing shared access to a spectrum commons,” in *First IEEE International Symposium on New Frontiers in Dynamic Spectrum Access Networks (DySPAN’05)*, nov. 2005, pp. 420–444.
- [42] J Brito, “The spectrum commons in theory and practice,” *Stanford Technology Law Review*, 2007.
- [43] C. Raman, R.D. Yates, and N.B. Mandayam, “Scheduling variable rate links via a spectrum server,” in *First IEEE International Symposium on New Frontiers in Dynamic Spectrum Access Networks (DySPAN’05)*, nov. 2005, pp. 110–118.
- [44] O. Ileri, D. Samardzija, and N.B. Mandayam, “Demand responsive pricing and competitive spectrum allocation via a spectrum server,” in *First IEEE International Symposium on New Frontiers in Dynamic Spectrum Access Networks (DySPAN’05)*, nov. 2005, pp. 194–202.
- [45] J. Huang, R.A. Berry, and M.L. Honig, “Spectrum sharing with distributed interference compensation,” in *First IEEE International Symposium on New Frontiers in Dynamic Spectrum Access Networks (DySPAN’05)*, Nov. 2005, pp. 88–93.
- [46] R. Etkin, A. Parekh, and D. Tse, “Spectrum sharing for unlicensed bands,” *IEEE Journal on Selected Areas in Communications*, vol. 25, no. 3, pp. 517–528, April 2007.

- [47] V. Brik, E. Rozner, S. Banerjee, and P. Bahl, “DSAP: a protocol for coordinated spectrum access,” in *First IEEE International Symposium on New Frontiers in Dynamic Spectrum Access Networks (DySPAN’05)*, nov. 2005, pp. 611–614.
- [48] L. Ma, X. Han, and C.C. Shen, “Dynamic open spectrum sharing MAC protocol for wireless ad hoc networks,” in *First IEEE International Symposium on New Frontiers in Dynamic Spectrum Access Networks (DySPAN’05)*, nov. 2005, pp. 203–213.
- [49] Y. Lee, “Opportunistic spectrum access in cognitive networks,” *Electronics Letters*, vol. 44, no. 17, pp. 1022–1024, 14 2008.
- [50] B. Hamdaoui, “Adaptive spectrum assessment for opportunistic access in cognitive radio networks,” *IEEE Transactions on Wireless Communications*, vol. 8, no. 2, pp. 922–930, Feb. 2009.
- [51] Xiangwei Zhou, G.Y. Li, Dongdong Li, Dandan Wang, and A.C.K. Soong, “Probabilistic resource allocation for opportunistic spectrum access,” *IEEE Transactions on Wireless Communications*, vol. 9, no. 9, pp. 2870–2879, September 2010.
- [52] Qian Chen, Ying-Chang Liang, M. Motani, and Wai-Choong Wong, “A two-Level MAC protocol strategy for opportunistic spectrum access in cognitive radio networks,” *IEEE Transactions on Vehicular Technology*, vol. 60, no. 5, pp. 2164–2180, June 2011.
- [53] T. Weiss and F. K. Jondral, “Spectrum pooling: An innovative strategy for the enhancement of spectrum efficiency,” *IEEE Communications Magazine*, vol. 42, pp. S8 – S14, March 2004.
- [54] Paul J. Kolodzy, “Interference temperature: a metric for dynamic spectrum utilization,” *International Journal of Network Management*, vol. 16, pp. 103–113, March 2006.
- [55] T. Charles Clancy, “Formalizing the interference temperature model,” *Wireless Communications and Mobile Computing*, vol. 7, no. 9, pp. 1077–1086, 2007.
- [56] A. Wagstaff and N. Merrick, “A subspace-based method for spectrum sensing,” in *SDR Forum Technical conference*, 2007.

- [57] T.C. Clancy, “Achievable capacity under the interference temperature model,” in *26th IEEE International Conference on Computer Communications (INFOCOM’07)*, May 2007, pp. 794–802.
- [58] T. Charles Clancy, “On the use of interference temperature for dynamic spectrum access,” *Annals of Telecommunications*, vol. 64, no. 7, pp. 573–585, 2009.
- [59] T.C. Clancy, “Spectrum shaping for interference management in cognitive radio networks,” in *SDR Forum Technical conference*, 2006.
- [60] Yonghong Zeng, Ying-Chang Liang, Zhongding Lei, Ser Wah Oh, F. Chin, and Sumei Sun, “Worldwide regulatory and standardization activities on cognitive radio,” in *5th IEEE Symposium on New Frontiers in Dynamic Spectrum (DySPAN’10)*, April 2010, pp. 1–9.
- [61] IEEE 802.22 Working Group, “IEEE 802.22 D1: Draft standard for wireless regional area networks,” March 2008.
- [62] C. Stevenson, G. Chouinard, Zhongding Lei, Wendong Hu, S. Shellhammer, and W. Caldwell, “IEEE 802.22: The first cognitive radio wireless regional area network standard,” *IEEE Communications Magazine*, vol. 47, no. 1, pp. 130–138, January 2009.
- [63] IEEE 1900, “in <http://www.ieeep1900.org>,” .
- [64] Supratim Deb, Vikram Srinivasan, and Ritesh Maheshwari, “Dynamic spectrum access in DTV whitespaces: design rules, architecture and algorithms,” in *Proceedings of the 15th annual international conference on Mobile computing and networking (MobiCom’09)*, New York, NY, USA, 2009, pp. 1–12, ACM.
- [65] Andrew Stirling, “White spaces – the new Wi-Fi?,” *International Journal of Digital Television*, vol. 1, no. 1, pp. 69–83, 2010.
- [66] P. Piggin and K.L. Stanwood, “Standardizing WiMAX solutions for coexistence in the 3.65 GHz band,” in *3rd IEEE Symposium on New Frontiers in Dynamic Spectrum (DySPAN’08)*, Oct. 2008, pp. 1–7.



- [67] M. Sherman, A.N. Mody, R. Martinez, C. Rodriguez, and R. Reddy, "IEEE standards supporting cognitive radio and networks, dynamic spectrum access, and coexistence," *IEEE Communications Magazine*, vol. 46, no. 7, pp. 72–79, July 2008.
- [68] RW Chang and R. Gibby, "A theoretical study of performance of an orthogonal multiplexing data transmission scheme," *IEEE Transactions on Communication Technology*, vol. 16, no. 4, pp. 529–540, 1968.
- [69] B. Saltzberg, "Performance of an efficient parallel data transmission system," *IEEE Transactions on Communication Technology*, vol. 15, no. 6, pp. 805–811, 1967.
- [70] Y. Wei, G. Bi, and G. Li, "Tone interference suppression in DS-SS systems with modified DFT," *Signal Processing*, vol. 88, no. 11, pp. 2817–2824, 2008.
- [71] T. Ihalainen, A. Viholainen, and M. Renfors, "On spectrally efficient multiplexing in cognitive radio systems," in *3rd International Symposium on Wireless Pervasive Computing (ISWPC'08)*. IEEE, pp. 675–679.
- [72] DG Mestdagh, M.R. Isaksson, and P. Odling, "Zipper VDSL: a solution for robust duplex communication over telephone lines," *IEEE Communications Magazine*, vol. 38, no. 5, pp. 90–96, 2000.
- [73] A.J. Redfern, "Receiver window design for multicarrier communication systems," *IEEE Journal on Selected Areas in Communications*, vol. 20, no. 5, pp. 1029–1036, 2002.
- [74] Renhui Xu and Ming Chen, "Spectral leakage suppression for DFT-based OFDM via adjacent subcarriers correlative coding," in *IEEE Global Telecommunications Conference (GLOBECOM'08)*, Dec. 2008, pp. 1–5.
- [75] S. Brandes, I. Cosovic, and M. Schnell, "Reduction of out-of-band radiation in OFDM systems by insertion of cancellation carriers," *IEEE Communications Letters*, vol. 10, no. 6, pp. 420–422, 2006.
- [76] I. Cosovic, S. Brandes, and M. Schnell, "Subcarrier weighting: a method for sidelobe suppression in OFDM systems," *IEEE Communications Letters*, vol. 10, no. 6, pp. 444–446, 2006.

- [77] I. Cosovic and V. Janardhanam, "Sidelobe suppression in OFDM systems," *Multi-Carrier Spread-Spectrum*, pp. 473–482, 2006.
- [78] I. Cosovic and T. Mazzoni, "Suppression of sidelobes in OFDM systems by multiple-choice sequences," *European transactions on telecommunications*, vol. 17, no. 6, pp. 623–630, 2006.
- [79] S. Pagadarai, A.M. Wyglinski, and R. Rajbanshi, "A novel sidelobe suppression technique for OFDM-Based cognitive radio transmission," in *3rd IEEE Symposium on New Frontiers in Dynamic Spectrum Access Networks (DySPAN'08)*. IEEE, 2008, pp. 1–7.
- [80] R. Xu and M. Chen, "A precoding scheme for DFT-based OFDM to suppress sidelobes," *IEEE Communications Letters*, vol. 13, no. 10, pp. 776–778, 2009.
- [81] "PHYDYAS-Physical layer for dynamic spectrum access and cognitive radio," Project website: [www.ict-phydyas.org](http://www.ict-phydyas.org).
- [82] T. Hidalgo Stitz, "Filter bank techniques for the physical layer in wireless communications," *Tampere University of Technology Publication; 919*, 2010.
- [83] H. Nyquist, "Certain topics in telegraph transmission theory," *Transactions of the American Institute of Electrical Engineers*, vol. 47, no. 2, pp. 617–644, 1928.
- [84] C.E. Shannon, "Communication in the presence of noise," *Proceedings of the IRE*, vol. 37, no. 1, pp. 10–21, 1949.
- [85] PP Vaidyanathan, "Multirate digital filters, filter banks, polyphase networks, and applications: A tutorial," *Proceedings of the IEEE*, vol. 78, no. 1, pp. 56–93, 1990.
- [86] PP Vaidyanathan, "Multirate systems and filter banks. 1993," .
- [87] N.J. Fliege, *Multirate digital signal processing: multirate systems, filter banks, wavelets*, John Wiley & Sons, Inc., 1994.
- [88] L.R. Rabiner, "Multirate digital signal processing," 1996.
- [89] F.J. Harris, *Multirate signal processing for communication systems*, Prentice Hall PTR, 2004.

- [90] PP Vaidyanathan, T.Q. Nguyen, Z. Doganata, and T. Saramaki, "Improved technique for design of perfect reconstruction FIR QMF banks with lossless polyphase matrices," *IEEE Transactions on Acoustics, Speech and Signal Processing*, vol. 37, no. 7, pp. 1042–1056, 1989.
- [91] RW Chang, "High-speed multichannel data transmission with bandlimited orthogonal signals," *Bell sys. Tech. J.*, vol. 45, pp. 1775–1796, 1966.
- [92] M. Bellanger and J. Daguët, "TDM-FDM transmultiplexer: Digital polyphase and FFT," *IEEE Transactions on Communications*, vol. 22, no. 9, pp. 1199–1205, 1974.
- [93] B. Hirosaki, "An orthogonally multiplexed QAM system using the discrete fourier transform," *IEEE Transactions on Communications*, vol. 29, no. 7, pp. 982–989, 1981.
- [94] B. Le Floch, M. Alard, and C. Berrou, "Coded orthogonal frequency division multiplex," *Proceedings of the IEEE*, vol. 83, no. 6, pp. 982–996, 1995.
- [95] M. ALARD, "Construction of a multicarrier signal," Nov 1996, WO Patent WO/1996/035,278.
- [96] P. Siohan and C. Roche, "Cosine-modulated filterbanks based on extended gaussian functions," *IEEE Transactions on Signal Processing*, vol. 48, no. 11, pp. 3052–3061, 2000.
- [97] T. Strohmer and S. Beaver, "Optimal OFDM design for time-frequency dispersive channels," *IEEE Transactions on Communications*, vol. 51, no. 7, pp. 1111–1122, 2003.
- [98] TIA Committee TR-8.5, "Wideband air interface isotropic orthogonal transform algorithm-public safety wideband data standards project digital radio technical standards," 2003.
- [99] B. Farhang-Boroujeny, "OFDM versus filter bank multicarrier," *IEEE Signal Processing Magazine*, vol. 28, no. 3, pp. 92–112, 2011.
- [100] P. Siohan, C. Siclet, and N. Lacaille, "Analysis and design of OFDM/OQAM systems based on filterbank theory," *IEEE Transactions on Signal Processing*, vol. 50, no. 5, pp. 1170–1183, 2002.

- [101] H. Bölcskei, “Orthogonal frequency division multiplexing based on offset QAM,” 2003.
- [102] M. Bellanger, “Filter banks and OFDM-OQAM for high throughput wireless LAN,” in *3rd International Symposium on Communications, Control and Signal Processing (ISCCSP’08)*, March 2008, pp. 758–761.
- [103] A. Amini, R. Kempter, and B. Farhang-Boroujeny, “A comparison of alternative filter-bank multicarrier methods in cognitive radios,” in *2006 Software Defined Radio Technical Conference and Product Exhibition (SDR’06)*, Orlando-Florida, Nov. 2006.
- [104] T.A. Ramstad and J.P. Tanem, “Cosine-modulated analysis-synthesis filterbank with critical sampling and perfect reconstruction,” in *ICASSP. IEEE*, 1991, pp. 1789–1792.
- [105] R.D. Koilpillai and PP Vaidyanathan, “Cosine-modulated FIR filter banks satisfying perfect reconstruction,” *IEEE Transactions on Signal Processing*, vol. 40, no. 4, pp. 770–783, 1992.
- [106] TQ Nguyen, “A class of generalized cosine-modulated filter bank,” in *IEEE International Symposium on Circuits and Systems (ISCAS’92)*. IEEE, 1992, vol. 2, pp. 943–946.
- [107] B. Farhang-Boroujeny and R. Kempter, “Multicarrier communication techniques for spectrum sensing and communication in cognitive radios,” *IEEE Commun. Mag. (Special Issue on Cognitive Radios for Dynamic Spectrum Access)*, vol. 48, no. 4, pp. 80–85, Apr. 2008.
- [108] B. Farhang-Boroujeny, “Filter bank spectrum sensing for cognitive radios,” *IEEE Transactions on Signal Processing*, vol. 56, no. 5, pp. 1801–1811, May 2008.
- [109] Haijian Zhang, Didier Le Ruyet, and Michel Terre, “Spectral efficiency comparison between OFDM/OQAM and OFDM-based CR networks,” *Wireless Communications and Mobile Computing*, 2008.
- [110] H. Zhang, D. Le Ruyet, D. Roviras, Y. Medjahdi, and H. Sun, “Spectral efficiency comparison of OFDM/FBMC for uplink cognitive radio networks,” *EURASIP Journal on Advances in Signal Processing*, vol. 2010, Article ID 621808, 14 pages, 2010.

- [111] T. Ihalainen, A. Viholainen, T.H. Stitz, and M. Renfors, “Reappearing primary user detection in FBMC/OQAM cognitive radios,” in *2010 Proceedings of the Fifth International Conference on Cognitive Radio Oriented Wireless Networks Communications (CROWNCOM)*, June 2010, pp. 1–5.
- [112] M. Trivellato, “Windowed/shaped OFDM and OFDM-OQAM: Alternative multicarrier modulations for wireless applications,” Master’s thesis, University of Padova, Italy, 2005.
- [113] A Skrzypczak, P Siohan, and JP Javaudin, “Power spectral density and cubic metric for the OFDM/OQAM modulation,” in *IEEE ISSPIT*, Vancouver-Canada, August 2006.
- [114] L. Vangelista and N. Laurenti, “Efficient implementations and alternative architectures for OFDM-OQAM systems,” *IEEE Transactions on Communications*, vol. 49, no. 4, pp. 664–675, 2001.
- [115] W. Kozek and A.F. Molisch, “Nonorthogonal pulseshapes for multicarrier communications in doubly dispersive channels,” *IEEE Journal on Selected Areas in Communications*, vol. 16, no. 8, pp. 1579–1589, 1998.
- [116] J.M. Morris and Y. Lu, “Discrete gabor expansion of discrete-time signals in via frame theory,” *Signal processing*, vol. 40, no. 2-3, pp. 155–181, 1994.
- [117] T. Hunziker and D. Dahlhaus, “Iterative symbol detection for bandwidth efficient nonorthogonal multicarrier transmission,” in *IEEE 51st Vehicular Technology Conference Proceedings (VTC-Spring 2000)*. IEEE, 2000, vol. 1, pp. 61–65.
- [118] S. Pagadarai, A. Kliks, H. Bogucka, and AM Wyglinski, “On non-contiguous multicarrier waveforms for spectrally opportunistic cognitive radio systems,” in *International Waveform Diversity and Design Conference (WDD’10)*. IEEE, 2010, pp. 177–181.
- [119] A. Kliks and H. Bogucka, “Improving effectiveness of the active constellation extension method for PAPR reduction in generalized multicarrier signals,” *Wireless Personal Communications*, pp. 1–12, 2010.
- [120] H.G. Feichtinger and T. Strohmer, *Gabor analysis and algorithms: Theory and applications*, Birkhauser, 1998.

- [121] O. Christensen, *An introduction to frames and Riesz bases*, Birkhauser, 2003.
- [122] H. Bölcskei, F. Hlawatsch, and H.G. Feichtinger, “Equivalence of DFT filter banks and gabor expansions,” in *SPIE Proc*, vol. 2569, pp. 128–139.
- [123] H. Bogucka, A.M. Wyglinski, S. Pagadarai, and A. Kliks, “Spectrally agile multicarrier waveforms for opportunistic wireless access,” *IEEE Communications Magazine*, vol. 49, no. 6, pp. 108–115, 2011.
- [124] J. Wexler and S. Raz, “Discrete gabor expansions,” *Signal processing*, vol. 21, no. 3, pp. 207–220, 1990.
- [125] S. Qian and D. Chen, “Discrete gabor transform,” *IEEE Transactions on Signal Processing*, vol. 41, no. 7, pp. 2429–2438, 1993.
- [126] S. Qian and D. Chen, “Optimal biorthogonal analysis window function for discrete gabor transform,” *IEEE Transactions on Signal Processing*, vol. 42, no. 3, pp. 694–697, 1994.
- [127] P. Prinz, “Calculating the dual gabor window for general sampling sets,” *IEEE Transactions on Signal Processing*, vol. 44, no. 8, pp. 2078–2082, 1996.
- [128] L. Auslander, I.C. Gertner, and R. Tolimieri, “The discrete zak transform application to time-frequency analysis and synthesis of nonstationary signals,” *IEEE Transactions on Signal Processing*, vol. 39, no. 4, pp. 825–835, 1991.
- [129] T. Genossar and M. Porat, “Can one evaluate the gabor expansion using gabor’s iterative algorithm?,” *IEEE Transactions on Signal Processing*, vol. 40, no. 8, pp. 1852–1861, 1992.
- [130] B. Farhang-Boroujeny and C. Schlegel, “Efficient multicarrier realization of full-rate space-time orthogonal block coded systems,” in *IEEE International Conference on Communications (ICC’03)*. IEEE, 2003, vol. 4, pp. 2267–2271.
- [131] M. El Tabach, J.P. Javaudin, and M. Héland, “Spatial data multiplexing over OFDM/OQAM modulations,” in *IEEE International Conference on Communications (ICC’07)*. IEEE, pp. 4201–4206.

- [132] C. L  l  , P. Siohan, and R. Legouable, “The alamouti scheme with CDMA-OFDM/OQAM,” *EURASIP Journal on Advances in Signal Processing*, vol. 2010, 2010.
- [133] N. Zorba and F. Bader, “Spatial diversity scheme to efficiently cancel ISI and ICI in OFDM-OQAM systems,” *Journal of Computer Networks and Communications*, vol. 2010, 2010.
- [134] A. Fasano and G. Di Blasio, “The duality between margin maximization and rate maximization discrete loading problems,” in *IEEE 5th Workshop on Signal Processing Advances in Wireless Communications (SPAWC’04)*, 2004, pp. 621–625.
- [135] A. Leke and J.M Cioffi, “A maximum rate loading algorithm for discrete multitone modulation systems,” in *IEEE Global Telecommunications Conference (GLOBECOM’97)*, 1997, vol. 3, pp. 1514–1518.
- [136] A.J. Goldsmith and P.P. Varaiya, “Capacity of fading channels with channel side information,” *IEEE Transactions on Information Theory*, vol. 43, no. 6, pp. 1986–1992, Nov 1997.
- [137] Wei Yu, Wonjong Rhee, S. Boyd, and J.M. Cioffi, “Iterative water-filling for gaussian vector multiple-access channels,” *IEEE Transactions on Information Theory*, vol. 50, no. 1, pp. 145–152, Jan. 2004.
- [138] A. Lozano, A.M. Tulino, and S. Verdu, “Optimum power allocation for parallel gaussian channels with arbitrary input distributions,” *IEEE Transactions on Information Theory*, vol. 52, no. 7, pp. 3033–3051, July 2006.
- [139] M. Bohge, J. Gross, A. Wolisz, and M. Meyer, “Dynamic resource allocation in OFDM systems: an overview of cross-layer optimization principles and techniques,” *IEEE Network*, vol. 21, no. 1, pp. 53–59, 2007.
- [140] Z. Shen, J.G. Andrews, and B.L. Evans, “Adaptive resource allocation in multiuser OFDM systems with proportional rate constraints,” *IEEE Transactions on Wireless Communications*, vol. 4, no. 6, pp. 2726 – 2737, Nov. 2005.



- [141] G. Song and Y. Li, "Utility-based resource allocation and scheduling in OFDM-based wireless broadband networks," *IEEE Communications Magazine*, vol. 43, no. 12, pp. 127–134, 2005.
- [142] M. Jiang and L. Hanzo, "Multiuser MIMO-OFDM for next-generation wireless systems," *Proceedings of the IEEE*, vol. 95, no. 7, pp. 1430–1469, 2007.
- [143] D.N.C. Tse, P. Viswanath, and L. Zheng, "Diversity-multiplexing tradeoff in multiple-access channels," *IEEE Transactions on Information Theory*, vol. 50, no. 9, pp. 1859–1874, 2004.
- [144] Y.J. Zhang and K.B. Letaief, "An efficient resource-allocation scheme for spatial multiuser access in MIMO/OFDM systems," *IEEE Transactions on Communications*, vol. 53, no. 1, pp. 107–116, 2005.
- [145] E.S. Lo, P.W.C. Chan, V.K.N. Lau, R.S. Cheng, KB Letaief, R.D. Murch, and W.H. Mow, "Adaptive resource allocation and capacity comparison of downlink multiuser MIMO-MC-CDMA and MIMO-OFDMA," *IEEE Transactions on Wireless Communications*, vol. 6, no. 3, pp. 1083–1093, 2007.
- [146] H. Jia, Z. Zhang, G. Yu, P. Cheng, and S. Li, "On the performance of IEEE 802.16 OFDMA system under different frequency reuse and subcarrier permutation patterns," in *IEEE International Conference on Communications (ICC'07)*, 2007, pp. 5720–5725.
- [147] J. Heo, I. Cha, and K.H. Chang, "Effective adaptive transmit power allocation algorithm considering dynamic channel allocation in reuse partitioning-based OFDMA system," *Springer Journal on Wireless Personal Communications*, vol. 43, no. 2, pp. 677–684, 2007.
- [148] S.G. Kiani, G.E. Oien, and D. Gesbert, "Maximizing multicell capacity using distributed power allocation and scheduling," in *IEEE Wireless Communications and Networking Conference (WCNC'07)*, 2007, pp. 1690–1694.
- [149] D.P. Bertsekas, *Nonlinear programming*, Athena Scientific Belmont, MA, 1999.
- [150] S. Boyd and L. Vandenberghe, *Convex optimization*, Cambridge Univ. Press, Cambridge, U.K., 2004.



- [151] P.J.M. Laarhoven and E.H.L. Aarts, *Simulated annealing: theory and applications*, vol. 37, Springer, 1987.
- [152] D.E. Goldberg, *Genetic algorithms in search, optimization, and machine learning*, Addison-wesley, 1989.
- [153] M.L. Fisher, “The lagrangian relaxation method for solving integer programming problems,” *Management science*, pp. 1–18, 1981.
- [154] S. Boyd and A. Mutapcic, “Subgradient methods,” *notes for EE364, Stanford University*, Winter. 2006-07.
- [155] Wei Yu and R. Lui, “Dual methods for nonconvex spectrum optimization of multicarrier systems,” *IEEE Transactions on Communications*, vol. 54, no. 7, pp. 1310–1322, 2006.

# Resource Allocation in Downlink Multicarrier Based Cognitive Radio Systems

*"The obvious is that which is never seen until someone expresses it simply"* **Kahlil Gibran.**

## Contents

---

<b>3.1 Introduction</b> . . . . .	<b>69</b>
<b>3.2 System Model</b> . . . . .	<b>73</b>
<b>3.3 Problem Formulation</b> . . . . .	<b>75</b>
<b>3.4 Proposed Low Complexity Algorithm</b> . . . . .	<b>78</b>
<b>3.5 Simulation Results</b> . . . . .	<b>85</b>
3.5.1 Case 1: Two Active PU Bands . . . . .	86
3.5.2 Case 2: Single Active PU Band . . . . .	91
<b>3.6 Chapter Summary and Conclusions</b> . . . . .	<b>93</b>
<b>3.A Appendix</b> . . . . .	<b>95</b>
3.A.1 Derivation of the Optimal Power Allocation Given By Equation (3.12)	95
<b>Bibliography</b> . . . . .	<b>97</b>

---

## 3.1 Introduction

Multicarrier communication systems have been suggested as a candidate for cognitive radio (CR) systems due to its flexibility to allocate resources among different secondary users (SUs).

The problem of resource allocation for conventional (non-cognitive) multiuser multicarrier systems has been widely studied (see e.g. [1–7] and references therein). In single user multicarrier systems, the data rate of the system is maximized under the total power constraint by adapting the transmit powers according to the waterfilling policy [1, 2]. A survey on bit and power allocation algorithms for single user multicarrier systems was presented in [3] where the main algorithms proposed to solve the main classes of loading problems, i.e. rate maximization problem (RM) and margin maximization problem (MM), are reviewed considering the total or individual power constraints. Additionally, the problem of the integer-bit loading is discussed and the optimal discrete solution as well as several low complexity algorithms are examined.

In the multiuser multicarrier systems, the overall capacity of the system can benefit from the available diversity where the probability of having the same subcarrier in deep fade for all the users is low. Jang et al. proved in [4] that the data rate of the downlink multiuser orthogonal frequency division multiplexing (OFDM) systems is maximized by assigning each subcarrier exclusively to the user with the highest signal-to-noise ratio (SNR). Afterwards, the transmit power is distributed using the waterfilling algorithm. This way of subcarrier allocation to the user with best channel may cause that the users with the higher average channel gain will be allocated most of the resources. To insure that all the users achieve similar data rate, Rhee et al. in [5] formulate a *max-min* problem to maximize the capacity of the user with the worse capacity. The authors allow the subcarrier sharing between users and write the problem in a standard convex form. Additionally, they propose an efficient suboptimal algorithm to reduce the computational complexity of the optimal scheme. In the suboptimal scheme, uniform power allocation is assumed in every subcarrier-user link and only the subcarrier with maximum achieved capacity is allocated to every user. Afterward, the rest of non-allocated subcarriers are assigned sequentially to the user with the lowest data rate. Shen et al. in [6] relaxed the equal data rate fairness constraint by proposing an algorithm that guarantees the proportional fairness between users in order to satisfy the different quality of service (QoS) requirements. Further details about the resource allocation problem in non-cognitive downlink multicarrier can be found in the recent survey [7] and the references therein.

In CR systems, two types of users (secondary users (SUs) and primary users (PUs)) and the mutual interference between them should be considered. The use of the resource allocation algorithms proposed for the non-cognitive is not always efficient because additional constraints should be introduced to keep the interference caused by the sidelobes in different subcarriers

below the maximum limit of the interference that can be tolerated by PUs. Therefore in CR systems, more power should be allocated to the good channels that at the same time introduce small amount of interference to the PUs which motivates the need of developing a wise resource allocation policy.

Wang et al. in [8] proposed an iterative partitioned single user waterfilling algorithm. The algorithm aims at maximizing the capacity of the CR system under the total power constraint as well as the per subcarrier power constraint formed by the PUs interference limit. The per subcarrier power constraint is evaluated based on the pathloss factor between the CR transmitter and the PU protection area. The mutual interference between the SU and PU was not considered. In [9] and [10], the authors proposed an optimal and two suboptimal power loading schemes using the Lagrange formulation. These loading schemes maximize the downlink transmission capacity of the CR system while keeping the interference induced to only one PU below a pre-specified interference threshold without considering the total power constraint. In [11], an algorithm called *RC algorithm* was presented for multiuser resource allocation in OFDM based CR systems. This algorithm uses a greedy approach for the subcarrier and power allocations by successively assigning bits, one at a time, based on the minimum SU power and minimum interference to PUs. The algorithm has a high computational complexity and a limited performance in comparison with the optimal solution. In [12], a risk return model is employed to consider the probability of PUs appearance and the misdirection errors. Based on this model, an energy-aware capacity expression is developed to take into account the subcarriers availability. The algorithm allocates the available power selectively to the underutilized subcarriers. Setoodeh and Haykin formulated in [13] the transmit power adaptation problem as a noncooperative game and use tools from control theory to study the equilibrium and transient of the proposed scheme. A robust version of the iterative water-filling algorithm (IWFA) is developed to address the variation in the spectrum occupancy and guarantee an acceptable level of performance of the CR system. Furthermore in [13], It is proved that the IWFA algorithm can prevent violating the permissible interference power levels even with outdated, i.e. delayed, channel information.

Recently, Almalfouh et al. in [14] considered the imperfect spectrum sensing errors in the allocation process, and proposed suboptimal algorithms to solve the problem. The powers are initially determined according to pre-defined criteria and based on that, the subcarriers are allocated to the users by solving a multiple-choice Knapsack problem (MCKP). In [15], a low

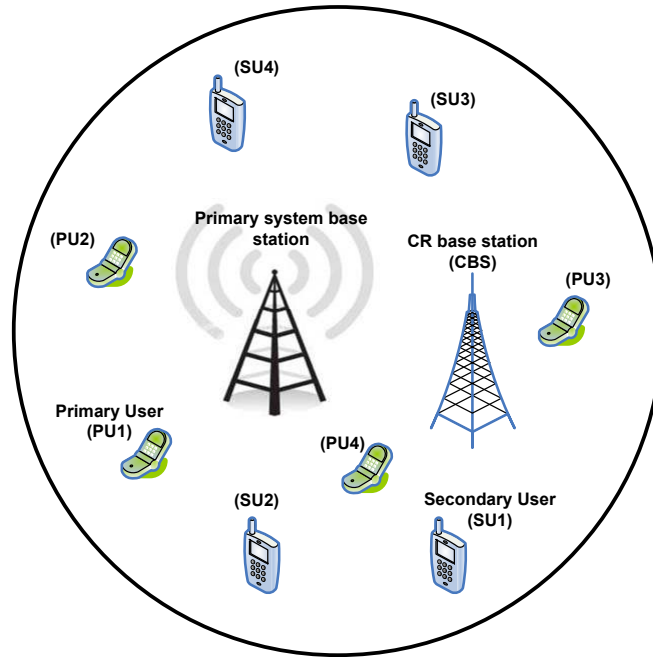
complexity suboptimal solution is proposed. The algorithm initially assumes that the maximum power that can be allocated to each subcarrier is equal to the power found by the conventional waterfilling, and it then modifies these values by applying a power reduction algorithm in order to satisfy the interference constraints. Experimental results like [16], emphasize the need for low interference constraints, where this algorithm has a limited performance. Moreover, the non transmission of the data over the subcarriers below the waterfilling level or the deactivated subcarriers due to the power reduction algorithm decreases the overall capacity of the CR system. An overview of the state-of-art results on resource allocation over space, time, and frequency for emerging CR wireless networks can be found in [17].

OFDM based CR systems suffer from high interference to the PUs due to large sidelobes of its filter frequency response. The insertion of the cyclic prefix (CP) in each OFDM symbol decreases the system capacity. The leakage among the frequency sub-bands has a serious impact on the performance of FFT-based spectrum sensing. In order to combat the leakage problem of OFDM, a very tight and hard synchronization implementation has to be imposed among the network nodes [18].

Filter bank multicarrier system (FBMC) can overcome the spectral leakage problem by minimizing the sidelobes of each subcarrier and therefore lead to high efficiency (in terms of spectrum and interference) [18,19]. Moreover, efficient use of filter banks for spectrum sensing when compared with the FFT-based periodogram and the Thomson's multitaper (MT) spectrum sensing methods have been recently discussed in [18] and [20].

In this chapter, we propose a resource allocation algorithm in order to maximize the downlink capacity of multicarrier based CR systems. We address the scenario in which the CR system is interfering with several PUs and hence, the different resources should be allocated to the SUs subject to both total power and interference constraints. The hybrid underlay and overlay spectrum access scheme is employed by the cognitive network so that the CR system is able to use the active as well as the non-active PU bands. The chapter contribution is summarized in the following points

- Because of the high complexity of the joint optimal scheme, a two-step suboptimal algorithm is proposed to perform the subcarrier and power allocation separately. We show that the proposed algorithm achieves a near optimal performance with a significant reduction in the computational complexity. The higher efficiency of the proposed algorithm



**Figure 3.1:** Cognitive Radio Network.

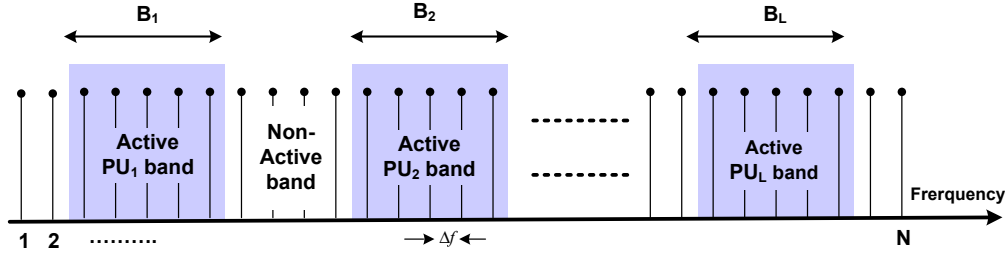
with respect to those presented in [11, 15] is also demonstrated.

- We investigate the efficiency of using FBMC-based physical layer in CR systems and compare it with that of OFDM-based systems.
- The advantage of enable the CR to access the active and non-active bands is verified and compared with an opportunistic access method that allow access to the non-active PU bands only.

This chapter encompasses research published in [21–26] and is organized as follows: Section 3.2 gives the system model while Section 3.3 formulates the problem. The proposed algorithm is presented in Section 3.4. Numerical results are presented in Section 3.5. Finally, Section 3.6 summarizes the chapter.

## 3.2 System Model

In this chapter, the downlink scenario shown in Fig. 3.1 will be considered. The CR system coexists with the PUs radio in the same geographical location. The cognitive base station (CBS) transmits to its SUs and causes interference to the PUs. Moreover, the PUs base station interferes with the SUs. The CR system’s frequency spectrum is divided into  $N$  subcarriers



**Figure 3.2:** Frequency distribution of the active and non-active primary bands.

each having a  $\Delta f$  bandwidth. The side by side frequency distribution of the PUs and SUs will be assumed (see Fig. 3.2). The frequency bands  $B_1, B_2, \dots, B_L$  have been occupied by the PUs (active PU bands) while the other bands represent the non-active PU bands. It's assumed that the CR system can use the non-active and active PU bands provided that the total interference introduced to the  $l^{th}$  PU band does not exceed the value  $I_{th}^l$  which is the maximum interference power that can be tolerated by  $PU_l$ .

The interference introduced by the  $i^{th}$  subcarrier to  $l^{th}$  PU,  $I_i^l(d_i, P_i)$ , is the integration of the power spectral density (PSD),  $\Phi_i(f)$ , of the  $i^{th}$  subcarrier across the  $l^{th}$  PU band,  $B_l$ , and can be expressed as [27]

$$I_i^l(d_i, P_i) = \int_{d_i - B_l/2}^{d_i + B_l/2} |g_i^l|^2 P_i \Phi_i(f) df \triangleq P_i \Omega_i^l \quad (3.1)$$

where  $P_i$  is the total transmit power emitted by the  $i^{th}$  subcarrier and  $d_i$  is the spectral distance between the  $i^{th}$  subcarrier and the  $l^{th}$  PU band.  $g_i^l$  denotes the channel gain between the CBS and the  $l^{th}$  PU on the subcarrier  $i$ .  $\Omega_i^l$  denotes the interference factor of the  $i^{th}$  subcarrier to the  $l^{th}$  PU band.

The interference power introduced by the  $l^{th}$  PU signal into the band of the  $i^{th}$  subcarrier is [27]

$$J_i^l(d_i, P_{PU_l}) = \int_{d_i - \Delta f/2}^{d_i + \Delta f/2} |y_i^l|^2 \psi_l(e^{j\omega}) d\omega \quad (3.2)$$

where  $\psi_l(e^{j\omega})$  is the PSD of the  $PU_l$  signal and  $y_i^l$  is the channel gain between the  $i^{th}$  subcarrier and  $l^{th}$  PU signal. The PSD expression,  $\Phi_i(f)$ , depends on the used multicarrier technique.

As described in the previous chapter, the OFDM PSD is expressed as follows

$$\Phi_{OFDM}(f) = \frac{\sigma_x^2}{T} \sum_k \left| G_T \left( f - \frac{k}{N} \right) \right|^2 \quad (3.3)$$

where  $G_T(f)$  is the Fourier transform of the pulse shape  $g_T(n)$ ,  $T = C + N$  is the length of the OFDM symbol in number of samples where  $C$  is the length of CP in number of samples and  $N$  is the IDFT size,  $\sigma_x^2$  is the variance of the zero mean (symmetrical constellation) and uncorrelated input symbols and  $\{k\}$  is the set of subcarrier indices. The pulse shape  $g_T(n)$  can be chosen as

$$g_T(n) = \begin{cases} 1 & n = 0, 1, \dots, T-1 \\ 0 & \text{otherwise} \end{cases} \quad (3.4)$$

and hence its Fourier transform is

$$|G_T(f)|^2 = T + 2 \sum_{r=1}^{T-1} (T-r) \cos(2\pi fr) \quad (3.5)$$

Additionally, the PSD of the FBMC can be expressed by [28]

$$\Phi_{FBMC} = \frac{\sigma_r^2}{\tau_o} \sum_k \left| H\left(f - \frac{k}{N}\right) \right|^2 \quad (3.6)$$

where  $H(f)$  is the frequency response of the prototype filter with coefficients  $h[n]$  with  $n = 0, \dots, W-1$ , where  $W = KN$ , and  $K$  is the length of each polyphase components (overlapping factor) while  $N$  is the number of the subcarriers. Additionally,  $\{k\}$  is the set of subcarrier indices,  $\sigma_r^2 = \frac{\sigma_x^2}{2}$  is the FBMC symbol variance, and  $\tau_o$  is FBMC symbol duration. Assuming that the prototype coefficients have even symmetry around the  $(\frac{KN}{2})^{th}$  coefficient, and the first coefficient is zero [29, 30], we get

$$|H(f)| = h[W/2] + 2 \sum_{r=1}^{\frac{W}{2}-1} h[(W/2) - r] \cos(2\pi fr) \quad (3.7)$$

To make a parallel between OFDM and FBMC, we place ourselves in the situation where both systems transmit the same quantity of information. This is the case if they have the same number of subcarriers  $N$  together with duration of  $\tau_o$  samples for FBMC real data and  $T = 2\tau_o$  for the complex QAM ones [28, 29].

### 3.3 Problem Formulation

The maximum achievable transmission rate of the  $i^{th}$  subcarrier,  $R_i$ , with the transmit power  $P_i$  can be evaluated using the Shannon capacity formula and is given by

$$R_i(P_i, h_i) = \Delta f \log_2 \left( 1 + \frac{P_i |h_i|^2}{\sigma_i^2} \right) \quad (3.8)$$



where  $h_i$  is the subcarrier fading gain from the CBS to the user.  $\sigma_i^2 = \sigma_{AWGN}^2 + \sum_{l=1}^L J_i^l$  where  $\sigma_{AWGN}^2$  is the mean variance of the additive white Gaussian noise (AWGN) and  $J_i^l$  is the interference introduced by the  $l^{th}$  PUs band into the  $i^{th}$  subcarrier of the CR system. The interference from PUs to the  $i^{th}$  subcarrier is assumed to be the superposition of large number of independent components, i.e.  $\sum_{l=1}^L J_i^l$ . Hence, by using central limit theorem, we can model the interference as AWGN. This assumption may not be valid for a low number of PU bands but can be considered as a good approximation for a large number of PU bands. This assumption is generally taken in this research area (e.g. [10, 15, 18]). Remark that the nature of the PUs interference on SUs band is the same on both OFDM and FBMC systems. The difference is only in the SUs interference to the PU bands, where FBMC has significantly lower interference, because its sidelobes are significantly smaller than those of OFDM.

Assuming that each subcarrier band is narrow, subcarriers can be approximated as channel with flat fading gains [31, 32]. It will be assumed that the channel changes slowly so that the channel gains remain constant during transmission. The total achievable rate for OFDM and FBMC systems is evaluated by summing the transmission rate across the different subcarriers [19, 33]. All the instantaneous fading gains are assumed to be perfectly known at the CR system. Remark that the channel gains between the CR system nodes can be obtained practically by means of classical channel estimation techniques while the channel gains between the CR system and PUs can be obtained by estimating the received signal power from the primary terminal when it transmits, under the assumptions of pre-knowledge on the primary transmit power levels and the channel reciprocity [34–37]. In [38], a blind parameter extraction algorithm is proposed to estimate the symbol period, useful symbol period, length of the cyclic prefix, number of subcarriers and the carrier frequency offset of the received OFDM signals when affected by additive Gaussian noise, time-dispersive channel, timing and frequency offsets.

Let  $v_{i,m}$  to be a subcarrier allocation indicator, i.e.  $v_{i,m} = 1$  if and only if the subcarrier  $i$  is allocated to the  $m^{th}$  user, and zero otherwise. It is assumed that each subcarrier can be used for transmission to at most one user at any given time. Our objective is to maximize the total capacity of the CR system subject to the instantaneous interference introduced to the PUs and total transmit power constraints. Therefore, the optimization problem can be formulated as follows

$$\begin{aligned}
 P1 : \quad & \max_{P_{i,m}} \sum_{m=1}^M \sum_{i=1}^N v_{i,m} R_{i,m} (P_{i,m}, h_{i,m}) \\
 \text{s.t.} \quad & v_{i,m} \in \{0, 1\}, \forall i, m \\
 & \sum_{m=1}^M v_{i,m} \leq 1, \forall i \\
 & \sum_{m=1}^M \sum_{i=1}^N v_{i,m} P_{i,m} \leq P_T \\
 & P_{i,m} \geq 0, \forall i \in \{1, 2, \dots, N\} \\
 & \sum_{m=1}^M \sum_{i=1}^N v_{i,m} P_{i,m} \Omega_i^l \leq I_{th}^l, \forall l \in \{1, 2, \dots, L\}
 \end{aligned} \tag{3.9}$$

where  $N$  denotes the total number of subcarriers,  $M$  is the number of users,  $I_{th}^l$  denotes the interference threshold prescribed by the  $l^{th}$  PU and  $P_T$  is the total SUs power budget.  $L$  is the number of the active PU bands. Inequality  $\sum_{m=1}^M v_{i,m} \leq 1, \forall i$  ensures that any given subcarrier can be allocated to at most one user.

The optimization problem  $P1$  is a combinatorial optimization problem and its complexity grows exponentially with the input size. In order to reduce the computational complexity, the problem is solved in two steps by many of the suboptimal algorithms in the scientific literature (see e.g. [4, 39–41] and references therein). In the first step, the subcarriers are assigned to the users and then the power is allocated for these subcarriers in the second step. Once the subcarriers are allocated to the users, the multiuser system can be viewed virtually as a single user multicarrier system. As proven in [4], the maximum data rate in downlink can be obtained if each subcarrier is assigned to the user who has the best channel gain for that subcarrier. The proof given in [4] is presented considering the non-cognitive multicarrier systems. The main difference between the optimization problem in the non-cognitive and cognitive systems is the existence of the interference constraints in the latter. However, the CBS has common interference factor for all the SUs, i.e. the value of  $\Omega_i^l$  is SU independent and hence, the proof is valid for the cognitive case as well. The subcarrier allocation algorithm is described in Algorithm 3.1. No fairness or data rate constraints are considered in this chapter. However, the fairness between users can be achieved by adopting the algorithms proposed for the non-cognitive multicarrier systems like ([5, 6] and references therein).

By applying Algorithm 3.1, the values of the channel indicators  $v_{i,m}$  are determined and hence for notation simplicity, the single user notation can be used. The values of the channel

---

**Algorithm 3.1** Subcarriers to User Allocation

---

**Initialization:**

Set  $v_{i,m} = 0 \forall i, m$

**Subcarrier Allocation:**

**for**  $i = 1$  to  $N$  **do**

$m^* = \arg \max_m \{h_{i,m}\}; v_{i,m^*} = 1$

**end for**

---

gains can be determined from the subcarrier allocation step as follows

$$h_i = \sum_{m=1}^M v_{i,m} h_{i,m} \quad (3.10)$$

Therefore, problem  $P1$  in (3.9) can be reformulated as follows

$$\begin{aligned} P2 : \quad & \max_{P_i} \sum_{i=1}^N \log_2 \left( 1 + \frac{P_i |h_i|^2}{\sigma_i^2} \right) \\ \text{s.t.} \quad & \sum_{i=1}^N P_i \Omega_i^l \leq I_{th}^l \quad \forall l \in \{1, 2, \dots, L\} \\ & \sum_{i=1}^N P_i \leq P_T \\ & P_i \geq 0 \quad \forall i \in \{1, 2, \dots, N\} \end{aligned} \quad (3.11)$$

The problem  $P2$  is a convex optimization problem. Solving for the optimal solution (See Appendix 3.A.1 for the derivation), we get

$$P_i^* = \left[ \frac{1}{\sum_{l=1}^L \alpha^l \Omega_i^l + \beta} - \frac{\sigma_i^2}{|h_i|^2} \right]^+ \quad (3.12)$$

where  $[x]^+ = \max(0, x)$ .  $\alpha^l, l \in \{1, 2, \dots, L\}$  and  $\beta$  are the Lagrange multipliers related to the interference and power constraints respectively. Solving for  $L + 1$  Lagrangian multipliers is computationally complex. The powers can be found numerically using ellipsoid or interior point method with a complexity  $\mathcal{O}(N^3)$  [15, 42]. In what follows, a low complexity algorithm that achieves near optimal performance is proposed.

### 3.4 Proposed Low Complexity Algorithm

The optimal solution for the optimization problem has a high computational complexity which makes it unsuitable for problems with a high number of subcarriers. A low complexity algo-

rithm is proposed by Zhang et al. in [15]. The subcarriers nulling and deactivating throughout this algorithm degrade the system capacity and cause the algorithm to have a limited performance in case of low interference constraints. To overcome the drawbacks of this algorithm, a low complexity power allocation algorithm is presented.

As described in [27] and [15], most of the interference affecting the PU bands is induced by the cognitive transmission in the subcarriers where the PU is active as well as in the subcarriers that are directly adjacent to the PU bands. Considering this fact, it can be assumed that each subcarrier belongs to the closest PU band and only introducing interference to it, and accordingly the optimization problem  $P2$  can be reformulated as follows

$$\begin{aligned}
 P3 : \quad & \max_{P'_i} \sum_{i=1}^N \log_2 \left( 1 + \frac{P'_i |h_i|^2}{\sigma_i^2} \right) \\
 \text{s.t.} \quad & \sum_{i \in N_l} P'_i \Omega_i^l \leq I_{th}^l \quad \forall l \in \{1, 2, \dots, L\} \\
 & \sum_{i=1}^N P'_i \leq P_T \\
 & P'_i \geq 0 \quad \forall i \in \{1, 2, \dots, N\}
 \end{aligned} \tag{3.13}$$

where  $N_l$  denotes the set of the subcarriers belonging to the  $l^{th}$  PU band. Using the same derivation leading to (3.12), we get

$$P'_i = \left[ \frac{1}{\alpha'_l \Omega_i^l + \beta'} - \frac{\sigma_i^2}{|h_i|^2} \right]^+ \tag{3.14}$$

where  $\alpha'_l$  and  $\beta'$  are the non-negative dual variables corresponding to the interference and power constraints respectively. The solution of the problem still has high computational complexity which encourages us to find a faster and more efficient power allocation algorithm.

If the interference constraints are ignored in  $P3$ , the solution of the problem will follow the well known waterfilling interpretation [2],

$$P_i^{(P_T)} = \left[ \lambda - \frac{\sigma_i^2}{|h_i|^2} \right]^+ \tag{3.15}$$

where  $\lambda$  is the waterfilling level. On the other hand, if the total power constraint is ignored, the Lagrangian of the problem can be written as

$$G^{(Int)} = - \sum_{i \in N_l} \log_2 \left( 1 + \frac{P_i^{(Int)} |h_i|^2}{\sigma_i^2} \right) + \alpha'_l{}^{(Int)} \left( \sum_{i \in N_l} P_i^{(Int)} \Omega_i^l - I_{th}^l \right) \tag{3.16}$$

where  $\alpha'_l$  is the Lagrange multiplier. Equating  $\frac{\partial G^{(Int)}}{\partial P_i^{(Int)}}$  to zero, we get

$$P_i^{(Int)} = \left[ \frac{1}{\alpha'_l{}^{(Int)} \Omega_i^l} - \frac{\sigma_i^2}{|h_i|^2} \right]^+ \tag{3.17}$$

where the value of  $\alpha_l'$  can be calculated by substituting (3.17) into  $\sum_{i \in N_l} P_i^{(Int)} \Omega_i^l = I_{th}^l$  to get

$$\alpha_l^{(Int)} = \frac{|N_l|}{I_{th}^l + \sum_{i \in N_l} \frac{\Omega_i^l \sigma_i^2}{|h_i|^2}} \quad (3.18)$$

It is clear that if the summation of the allocated power under only the interference constraints is lower than or equal to the available total power, i.e.  $\sum_{i=1}^N P_i^{(Int)} \leq P_T, \forall i \in \{1, 2, \dots, N\}$ , then (3.17) and (3.18) will be the optimal solution for the optimization problem *P3*. In most of the cases, the total power budget is considerably lower than this summation, and hence the **Power Interference (PI) constrained algorithm**, referred to as *PI-Algorithm*, is proposed to allocate the power under both total power and interference constraints. A flowchart that describes the *PI-Algorithm* is depicted in Fig. 3.3 where the following stages are performed

- **Maximum power determination:** we can start by assuming that the maximum power that can be allocated for a given subcarrier  $P_i^{Max}$  is determined according to the interference constraints only by using (3.17) and (3.18) for every set of subcarriers  $N_l, \forall l \in \{1, 2, \dots, L\}$ . By this assumption, we can guarantee that the interference introduced to the PU bands will be under the pre-specified thresholds.
- **Power constraint testing:** once the maximum power  $P_i^{Max}$  is determined, the total power constraint is tested. If the total power constraint is satisfied, then the solution has been found and is equal to the maximum power that can be allocated to each subcarrier, i.e.  $P_i' = P_i^{Max}$ . Otherwise, continue to the next steps.
- **Power budget distribution:** the available power budget should be distributed among the subcarriers ensuring that the power allocated to each subcarrier is lower than or equal to the maximum power that can be allocated to each subcarrier  $P_i^{Max}$ , and hence the following problem should be solved

$$\begin{aligned} P4 : \quad & \max_{P_i^{W.F.}} \sum_{i=1}^N \log_2 \left( 1 + \frac{P_i^{W.F.} |h_i|^2}{\sigma_i^2} \right) \\ \text{s.t.} \quad & \sum_{i=1}^N P_i^{W.F.} \leq P_T \\ & 0 \leq P_i^{W.F.} \leq P_i^{Max} \end{aligned} \quad (3.19)$$

The problem *P4* is called "*cap-limited*" waterfilling [3]. The problem can be solved efficiently using the concept of the conventional waterfilling. As described in Fig. 3.4, given

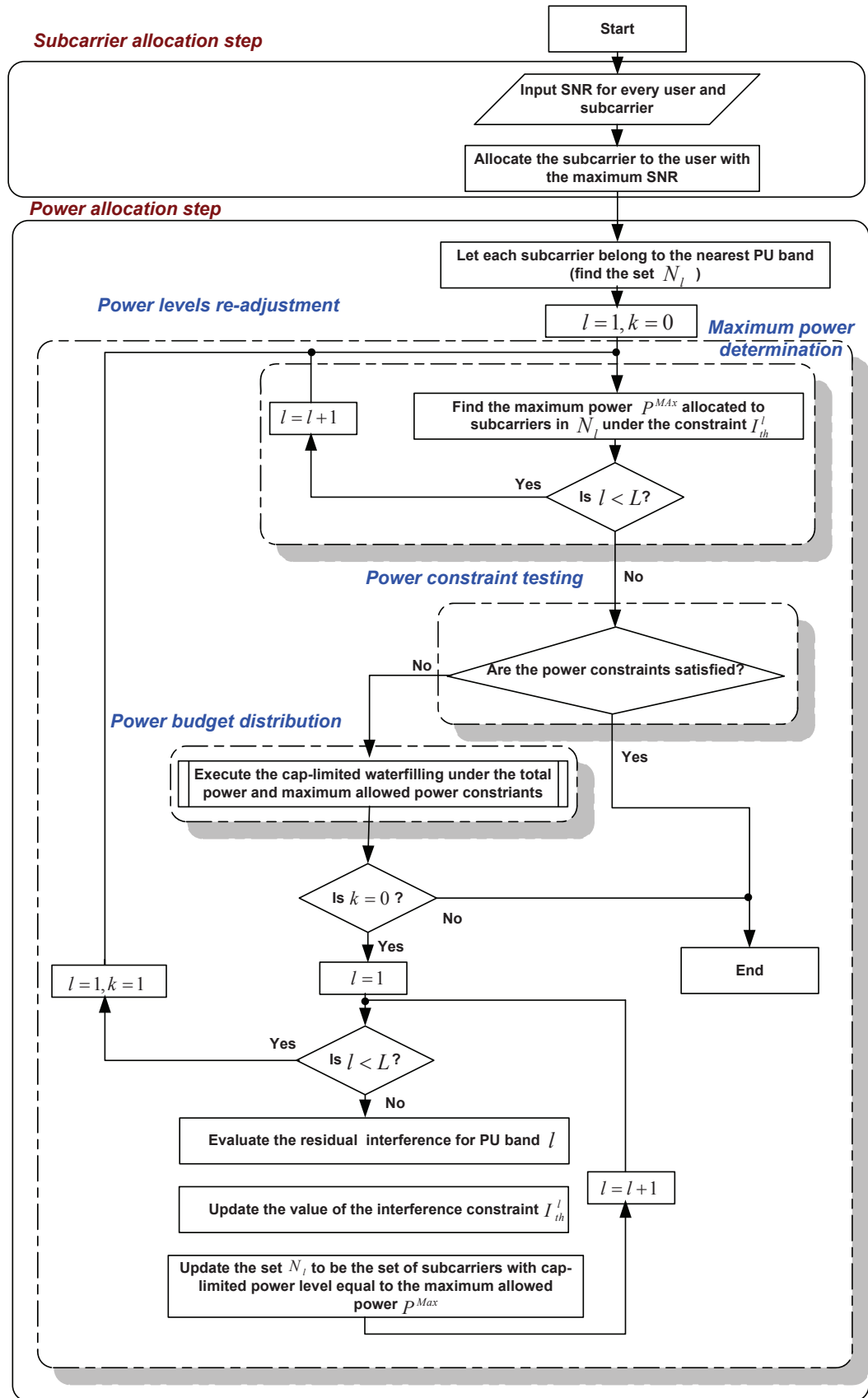
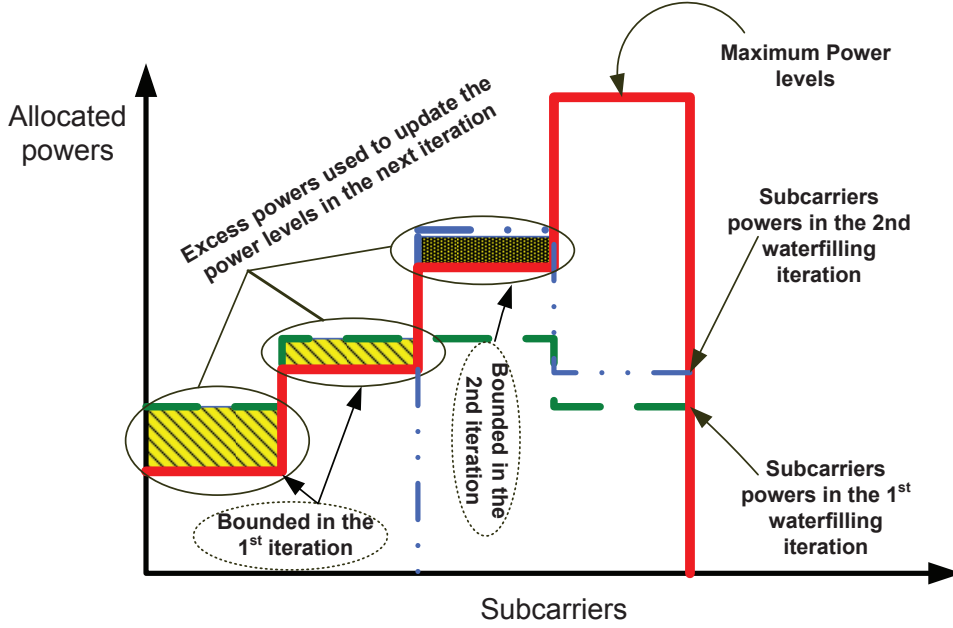


Figure 3.3: Flowchart of the proposed subcarrier and power allocation algorithm.



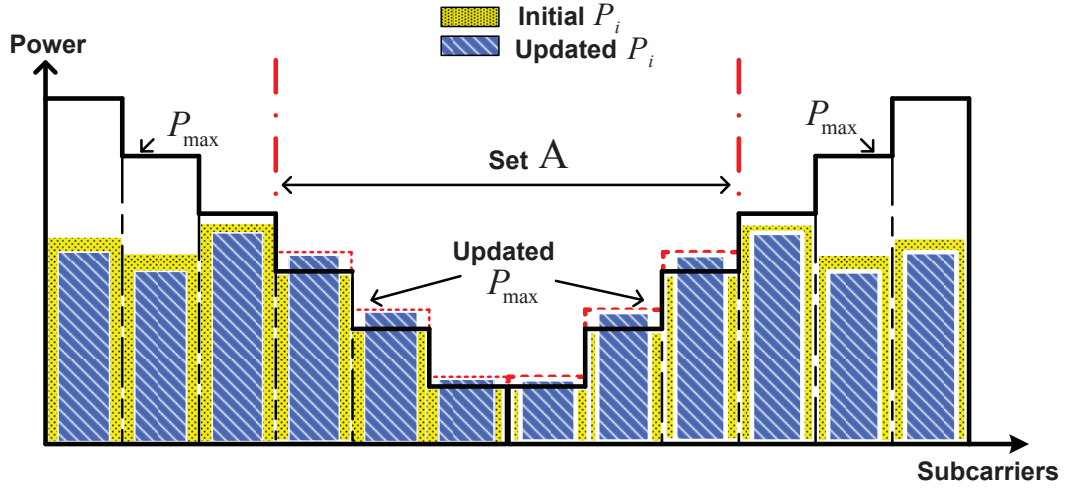
**Figure 3.4:** Cap-Limited waterfilling graphical example.

the initial waterfilling solution, the channels that violate the maximum power  $P_i^{Max}$  are determined and upper bounded with  $P_i^{Max}$ . The total power budget is reduced by subtracting the power assigned so far. At the next step, the algorithm proceeds to successive waterfilling over the subcarriers that did not violate the maximum power  $P_i^{Max}$  in the last step. These procedures are repeated until the allocated power  $P_i^{W.F}$  doesn't violate the maximum power  $P_i^{Max}$  in any of the subcarriers in the new iteration. Low computational complexity implementation of the "cap-limited" waterfilling can be found in [43].

- **Power levels re-adjustment:** the solution  $P_i^{W.F}$  of the problem  $P4$  satisfies the total power constraint of the problem  $P3$  with equality which is not the case for the different interference constraints  $I_{th}^l$ . Since it is assumed that  $P_i^{W.F} \leq P_i^{Max}$ , some of the powers allocated to the subcarriers will not reach the maximum allowable values. This will make the interference introduced to the PU bands below the thresholds  $I_{th}^l$ . In order to take advantage of all the allowable interference, the values of the maximum power that can be allocated to each subcarrier  $P_i^{Max}$  should be updated depending on the residual interference. The residual interference can be determined as follows

$$I_{Residual}^l = I_{th}^l - \sum_{i \in N_l} P_i^{W.F} \Omega_i^l \quad (3.20)$$

Assuming that  $A_l \subset N_l$  is the set of the subcarriers that reach their maximum, i.e.



**Figure 3.5:** Example of the SUs allocated power using proposed *PI-Algorithm*.

$P_i^{W.F} = P_i^{Max}, \forall i \in A_l$ , then,  $P_i^{Max}, \forall i \in A_l$  can be updated by applying the equations (3.17) and (3.18) on the subcarriers whose indices are in the set  $A_l$  with the following interference constraints

$$I_{th}^l = I_{Residual}^l + \sum_{i \in A_l} P_i^{W.F} \Omega_i^l \quad (3.21)$$

After determining the updated values of  $P_i^{Max}$ , the "cap-limited" waterfilling is performed again to find the final solution  $P_i' = P_i^{W.F}$ . Now, the solution  $P_i'$  satisfies approximately the interference constraints with equality and guarantees that the total power used is equal to  $P_T$ .

Fig.3.5 describes graphically the *PI-Algorithm* where the maximum powers are determined firstly, and followed by specifying the subcarriers in the set  $\mathcal{A}$  with allocated powers equals to the maximum allowed powers. The maximum powers are updated to the subcarriers in the set  $\mathcal{A}$  and finally, the "cap-limited" waterfilling is performed to find the final power allocation. The implementation procedures of the *PI-Algorithm* and the "cap-limited" algorithm are described in Algorithm 3.2 and Algorithm 3.3 respectively.

The computational complexity of Step 2 in the proposed *PI-Algorithm* (Algorithm 3.2) is  $\sum_{l=1}^L \mathcal{O}(|N_l| \log |N_l|) \leq \mathcal{O}(N \log N)$ . Steps 4 and 6 of the algorithm execute the "cap-limited" waterfilling which has a complexity of  $\mathcal{O}(N \log N)$ . Step 5 has a complexity of  $\sum_{l=1}^L \mathcal{O}(|A_l| \log |A_l|) + \mathcal{O}(L) \leq \mathcal{O}(N \log N) + \mathcal{O}(L)$ . Therefore, the overall complexity of the algorithm is lower than  $\mathcal{O}(N \log N) + \mathcal{O}(L)$ . In comparison with the computational complexity of the optimal solution, i.e.  $\mathcal{O}(N^3)$ , the proposed algorithm has much lower computational



---

**Algorithm 3.2 PI-Algorithm**

---

1. **Initialize**  $\mathcal{N} = \{1, 2, \dots, N\}$ ,  $\mathcal{N}_l = N_l$ ,  $I_{Residual}^l = 0$ ,  $S = P_T$  and  $\mathcal{A}_l = \emptyset$ .
  2.  $\forall l \in \{1, 2, \dots, L\}$ , sort  $\left\{ H_i = \frac{\sigma_i^2}{|h_i|^2} \Omega_i, i \in \mathcal{N}_l \right\}$  in decreasing order with  $k$  being the sorted index. Find the  $P_i^{Max}$  as follows:
    - (a)  $H_{sum} = \sum_{i \in \mathcal{N}_l} H_i$ ,  $\alpha_l'^{(Int)} = |\mathcal{N}_l| / (I_{th}^l + H_{sum})$ ,  $n = 1$ .
    - (b) **while**  $\alpha_l'^{(Int)} > H_{k(n)}^{-1}$  **do**  
 $H_{sum} = H_{sum} - H_{k(n)}$ ,  $\mathcal{N}_l = \mathcal{N}_l \setminus \{k(n)\}$ ,  $\alpha_l'^{(Int)} = |\mathcal{N}_l| / (I_{th}^l + H_{sum})$ ,  
 $n = n + 1$   
**end while**
    - (c) Set  $P_i^{Max} = \left[ \frac{1}{\alpha_l'^{(Int)} \Omega_i^l} - \frac{\sigma_i^2}{|h_i|^2} \right]^+$
  3. **if**  $\sum_{i \in \mathcal{N}} P_i^{Max} \leq P_T$   
Let  $P_i' = P_i^{Max}$  and stop the algorithm.  
**end if**
  4. Execute the "cap-limited" waterfilling (Algorithm 3.3) and find the set  $\mathcal{A}_l \subset N_l$  where  $P_i^{W.F} = P_i^{Max}$ .
  5. Evaluate  $I_{Residual}^l = I_{th}^l - \sum_{i \in N_l} P_i^{W.F} \Omega_i^l$  and set  $\mathcal{N}_l = \mathcal{A}_l$ ,  $I_{th}^l = I_{Residual}^l + \sum_{i \in \mathcal{A}_l} P_i^{W.F} \Omega_i^l$  and apply again only step 2 to update  $P_i^{Max}$ .
  6. Execute the "cap-limited" waterfilling (Algorithm 3.3) and set  $P_i' = P_i^{W.F}$ .
-

---

**Algorithm 3.3** Cap-Limited Waterfilling

---

1. **Initialize**  $\mathcal{F} = \mathcal{M} = \mathcal{N} = \{1, 2, \dots, N\}$ ,  $\bar{P}_i = P_i^{Max}$ , and  $S = P_T$ .
  2. Sort  $\left\{ T_i = \frac{\sigma_i^2}{|h_i|^2}, i \in \mathcal{N} \right\}$  in decreasing order with  $J$  being the sorted index. Find the waterfilling  $\lambda$  as follows:
    - (a)  $T_{sum} = \sum_{i \in \mathcal{N}} T_i$ ,  $\lambda = (T_{sum} + S) / |\mathcal{N}|$ ,  $n = 1$ .
    - (b) **while**  $T_{J(n)} > \lambda$  **do**  
 $T_{sum} = T_{sum} - T_{J(n)}$ ,  $\mathcal{N} = \mathcal{N} \setminus \{J(n)\}$ ,  $\lambda = (T_{sum} + S) / |\mathcal{N}|$ ,  $n = n + 1$   
**end while**
    - (c) Set  $P_i^{W.F} = [\lambda - T_i]^+$ ,  $\forall i \in \mathcal{F}$
  3. **repeat**  
**if**  $P_i^{W.F} \geq \bar{P}_i$   
Let  $P_i^{W.F} = \bar{P}_i$ ,  $S = S - P_i^{W.F}$ ,  $\mathcal{M} = \mathcal{M} \setminus \{i\}$ ,  $\mathcal{N} = \mathcal{M}$ , and go to step 2;  
**end if**  
**until**  $P_i^{W.F} \leq \bar{P}_i, \forall i \in \mathcal{F}$
- 

complexity specially when the number of the subcarriers  $N$  is high. Table. 3.1 summarizes the complexity of the different algorithms.

**Table 3.1:** Computational complexity comparison

Algorithm	Complexity
<i>Exhaustive enumeration</i>	$\mathcal{O}(N^3 M^N)$
<i>Optimal</i>	$\mathcal{O}(N^3)$
<i>Zhang [15]</i>	$\mathcal{O}(N \log N) + \mathcal{O}(LN)$
<i>PI-Algorithm</i>	$\mathcal{O}(N \log N) + \mathcal{O}(L)$

### 3.5 Simulation Results

In the simulations, a scenario like the one depicted in Fig.3.1 is considered. A multicarrier system of  $M = 3$  cognitive users and  $N = 32$  subcarriers is assumed. The values of  $\Delta f$

and  $P_T$  are assumed to be 0.3125 MHz and 1 watt respectively. AWGN of variance  $10^{-6}$  is assumed. Without loss of generality, the interference induced by the PUs to the SUs band is assumed to be negligible. The channel gains  $h$  and  $g$  are outcomes of independent, identically distributed (i.i.d) Rayleigh random variables (rv's) with mean equal to 1, and assumed to be perfectly known at the CBS. OFDM and FBMC based cognitive radio systems are evaluated. The OFDM system is assumed to have a 6.67% of its symbol time as CP. For FBMC system, the prototype coefficients are assumed to be equal to PHYDYAS coefficients with overlapping factor  $K = 4$ , are defined by [44] [30]

$$\begin{aligned} h[0] &= 0; \\ h[n] &= 1 - 1.94392 \cos\left(\frac{2\pi n}{128}\right) + \sqrt{2} \cos\left(\frac{4\pi n}{128}\right) - 0.470294 \cos\left(\frac{6\pi n}{128}\right); 1 \leq n \leq 127 \end{aligned} \quad (3.22)$$

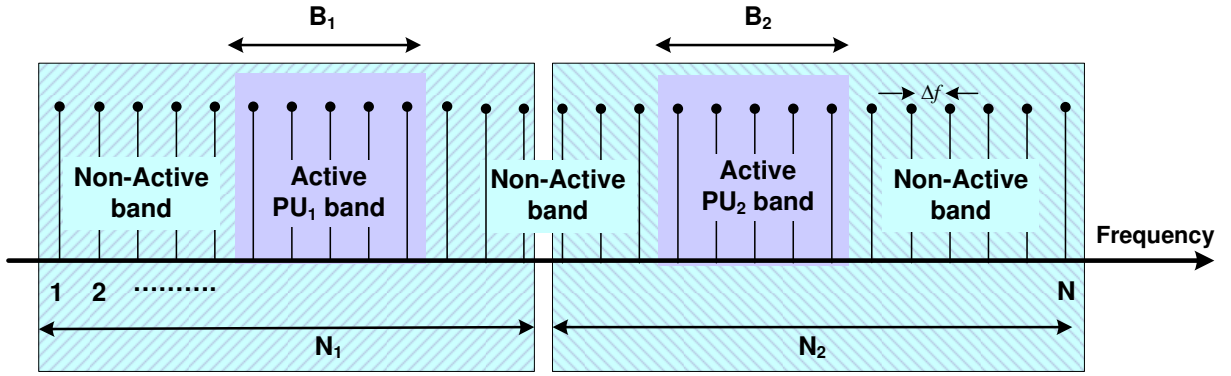
For the purpose of performance comparison, the following algorithms are considered:

1. **Optimal**: the subcarriers are allocated by Algorithm 3.1 while the powers are allocated by using the interior point method.
2. **PI**: the subcarriers are allocated by Algorithm 3.1 while the powers are allocated by the proposed algorithm described in Algorithm 3.2.
3. **Zhang** [15]: the subcarriers are allocated by Algorithm 3.1 while the power allocation is performed in two steps. The powers are allocated initially according to the conventional waterfilling and then modified to satisfy the interference constraints by applying a power reduction algorithm.
4. **RC** [11]: the algorithm uses a greedy approach for the subcarrier and power allocation. The algorithm assigns one bit a time to the SUs based on the required power by SUs as well as the induced interference to the PUs.

All the results have been averaged over 1000 iterations. The cases of single and two active PU bands are considered in the simulation.

### 3.5.1 Case 1: Two Active PU Bands

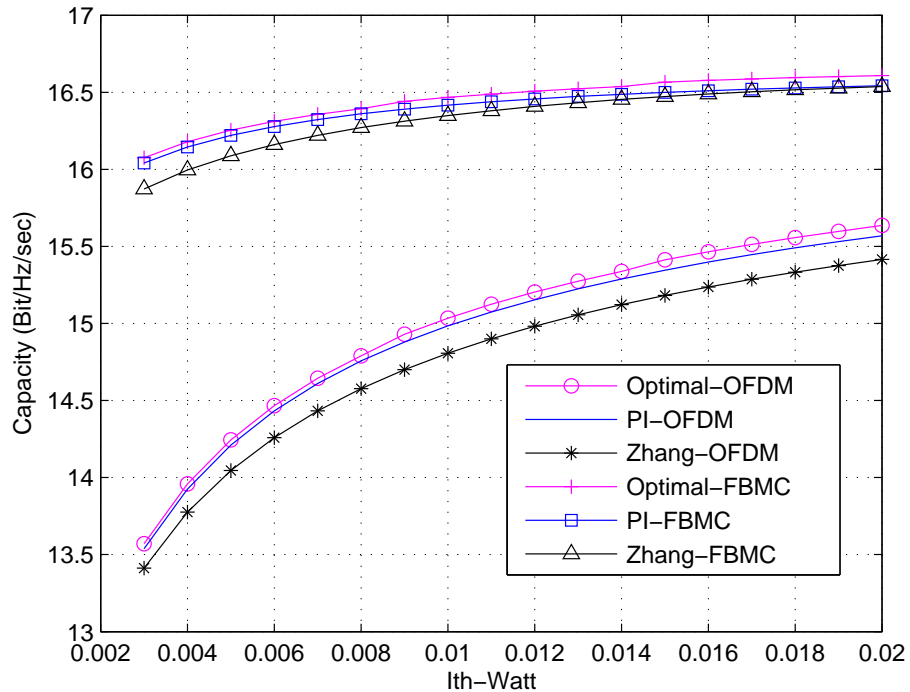
In this case, two interference constraints belonging to two active PU bands, i.e.  $L = 2$ , are assumed as depicted in Fig. 3.6. Each active PU band is assumed to have six subcarriers



**Figure 3.6:** Frequency distribution with two active PU bands.

( $|N_1| = |N_2| = 16$ ). The achieved capacity using *optimal*, *PI* and *Zhang* algorithms for different interference constraints where  $I_{th}^1 = I_{th}^2$  is plotted in Fig. 3.7. It can be noted that the proposed *PI-algorithm* approaches the optimal solution and outperforms *Zhang* algorithm.

The effect of assuming that every subcarrier belongs to the closest PU band and introducing interference to it only on the net interference introduced to the active PU bands is studied in Fig.3.8 and Fig. 3.9 for  $PU_1$  and  $PU_2$  respectively.



**Figure 3.7:** Achieved capacity vs allowed interference threshold for OFDM and FBMC based CR systems - Two active PU bands.

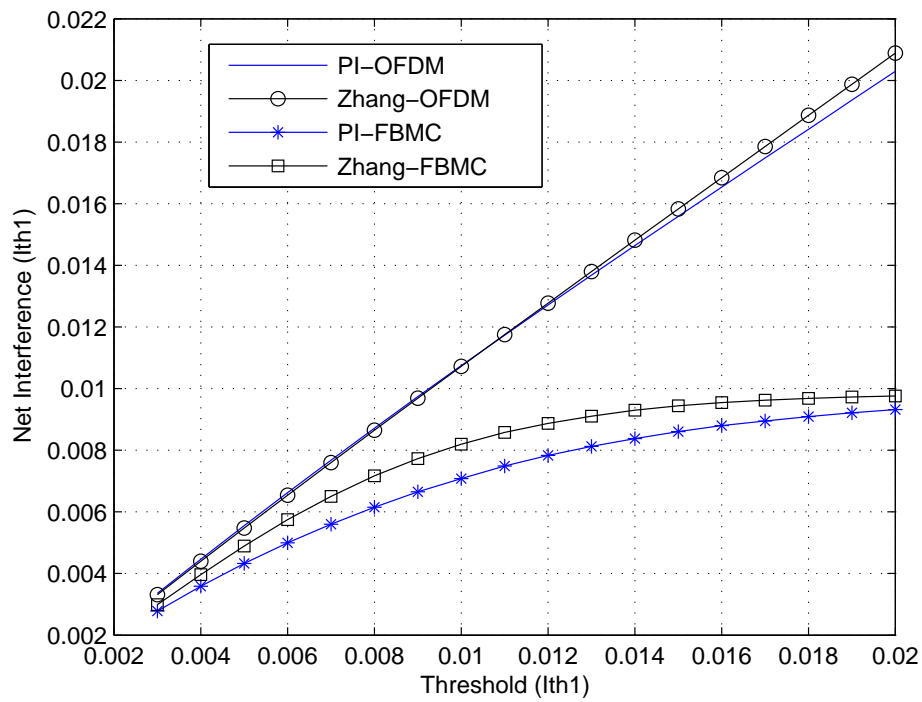


Figure 3.8: Total interference introduced to the  $PU_1$  vs interference threshold.

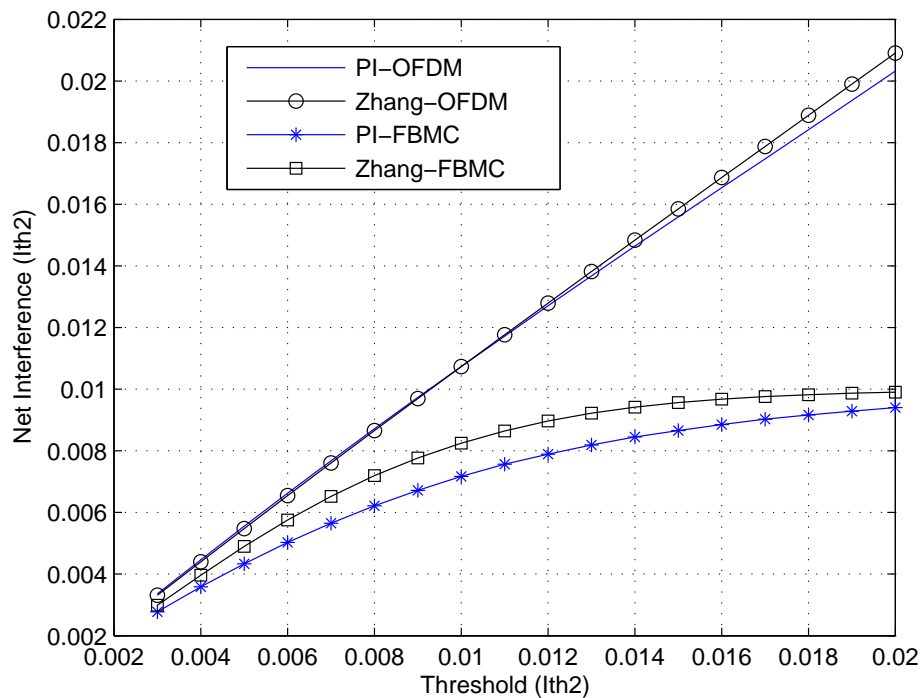
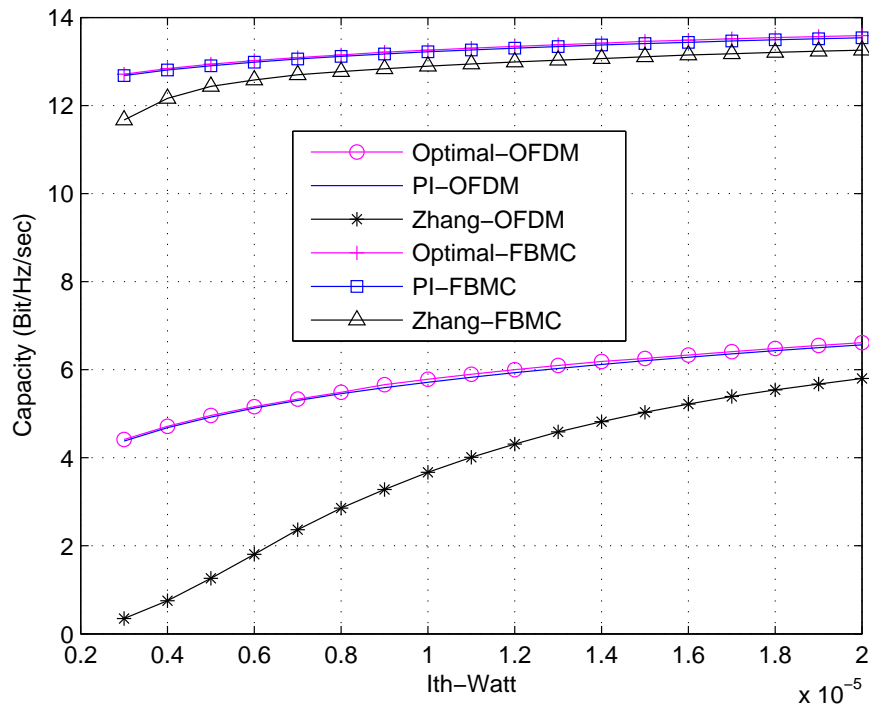


Figure 3.9: Total interference introduced to the  $PU_2$  vs interference threshold.

It can be observed that the net interference induced using the *PI-algorithm* approximately satisfies the pre-specified interference constraints which makes the assumption reasonable. Unlike the OFDM based CR system, the interference induced by the FBMC based system does not reach the pre-specified thresholds. This is because the FBMC based CR system reaches the maximum interference that can be introduced to the PU using the given power budget. Moreover, the interference induced by the proposed algorithm is less than that using *Zhang* algorithm. Returning to Fig.3.7, one can notice that the interference constraints above  $I_{th}^l = 10$  mWatt start to have no effect on the achieved capacity of the FBMC system. This indicates also that the FBMC system reaches the maximum interference for the given power budget. The small difference between the net interference values above  $I_{th}^l = 10$  mWatt is due to the averaging over different channel realizations.

The achieved capacity of the different algorithms is plotted in Fig. 3.10 with lower values of the interference constraints. It can be noticed that *Zhang* algorithm has a limited performance with low interference constraints because the algorithm turns off the subcarriers that have a noise level which is higher than the initial waterfilling level and never uses these subcarriers again even if the new waterfilling level exceeds its noise level. Moreover, the algorithm

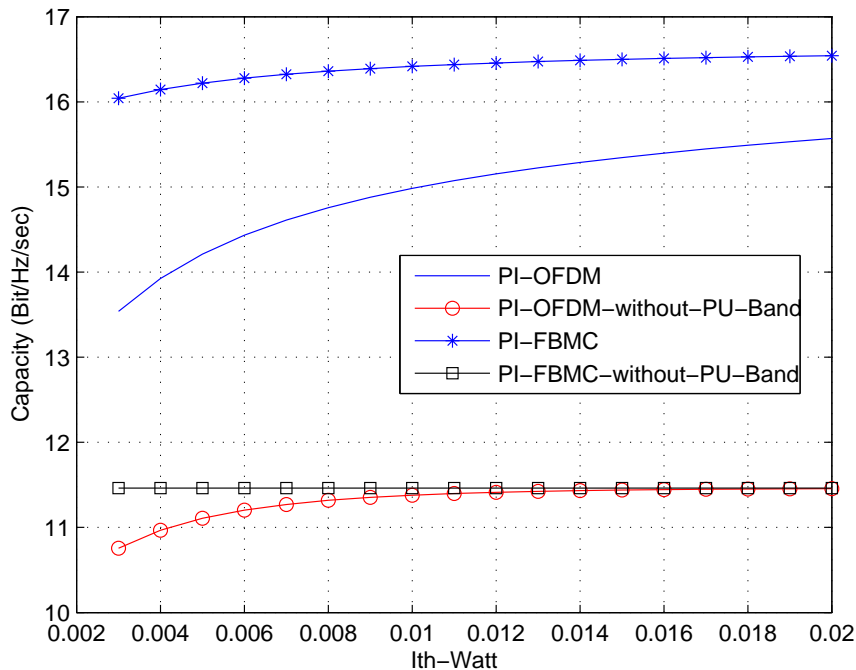


**Figure 3.10:** Achieved CR vs allowed interference threshold (low) for OFDM and FBMC based CR systems - Two active bands.

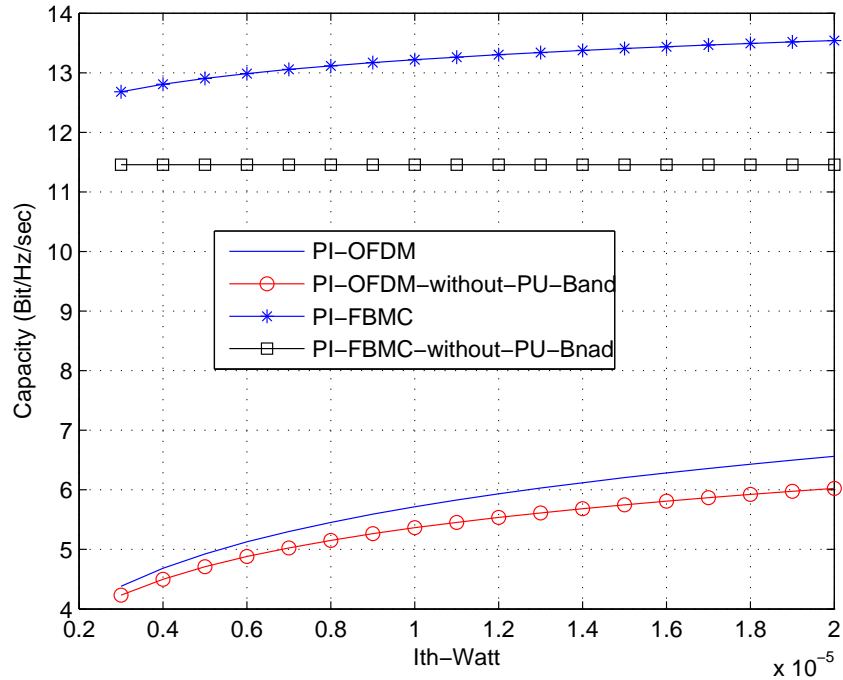
deactivates some subcarriers, i.e. transmit zero power, in order to ensure that the interference introduced to PU bands is below the pre-specified thresholds. The lower the interference constraints, the higher the number of deactivated subcarriers is, which justifies the limited performance of this algorithm in case of low interference constraints.

To show the efficiency of transmitting over the active PU bands as well as the non-active bands, Fig.3.11 and Fig.3.12 show the achieved capacity using the PI algorithm with and without allowing the SUs to transmit over the PU active bands. The capacity of the CR system transmitting on both the active and non-active bands is higher than that of the system in which the transmission takes place on the non-active bands only. Since the cognitive transmission in the active PU band introduces more interference to the PUs than the other subcarriers, low power levels can be used in these bands with low interference constraints. This justifies why the difference between the two systems decreases when the interference constraints decrease.

For all the presented results, the capacity of FBMC based CR system is higher than that of the one based on OFDM because the sidelobes in FBMC's PSD are smaller than those in OFDM, which introduces less interference to the PUs. Moreover, the inserted CP in OFDM



**Figure 3.11:** Achieved capacity vs allowed interference threshold with and without transmitting over active bands- Two active PU bands.



**Figure 3.12:** Achieved capacity vs allowed interference threshold (low) with and without transmitting over active bands - Two active PU bands.

based CR systems reduces the total capacity of the system. It can be noticed also that the interference condition introduces a small restriction on the capacity of FBMC based CR systems which is not the case in OFDM based CR systems.

### 3.5.2 Case 2: Single Active PU Band

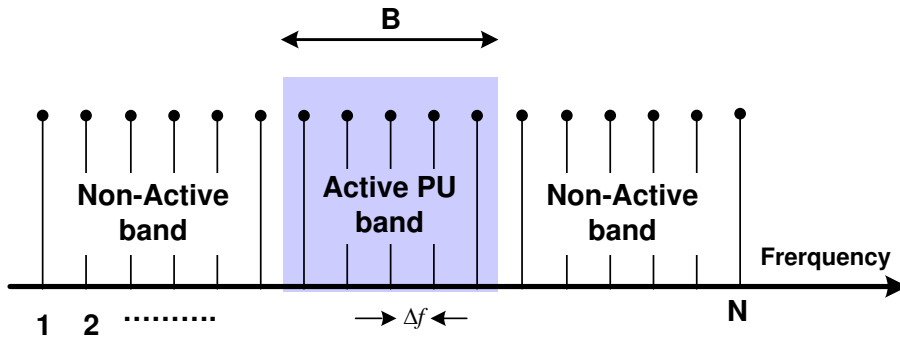
The *RC* algorithm can be used if there is only one active PU band, i.e.  $L = 1$ . The *RC* algorithm allocates the subcarriers and bits considering the relative importance between the power needed to transmit and the interference induced to the PU band. In order to compare the proposed *PI-algorithm* with *RC* algorithm, One active PU band with 12 subcarriers is assumed in this case as depicted in Fig. 3.13.

For fair comparison, the same bit mapping used in [11] is considered, that is

$$b_i = \left\lfloor \log_2 \left( 1 + \frac{P'_i |h_i|^2}{\sigma_i^2} \right) \right\rfloor \quad (3.23)$$

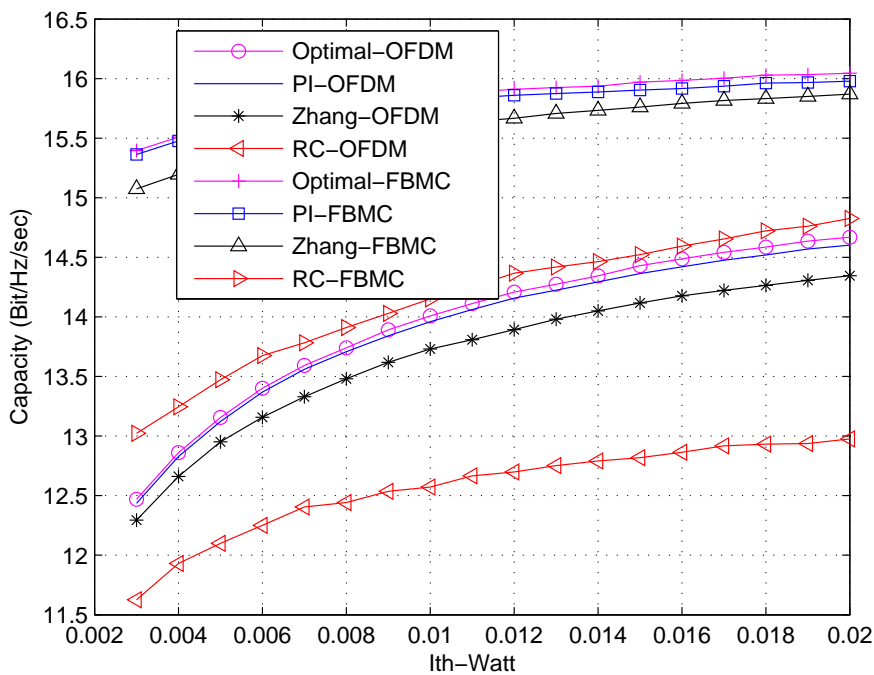
where  $b_i$  denotes the maximum number of bits in the symbol transmitted in the  $i^{th}$  subcarrier and  $\lfloor \cdot \rfloor$  denotes the floor function.



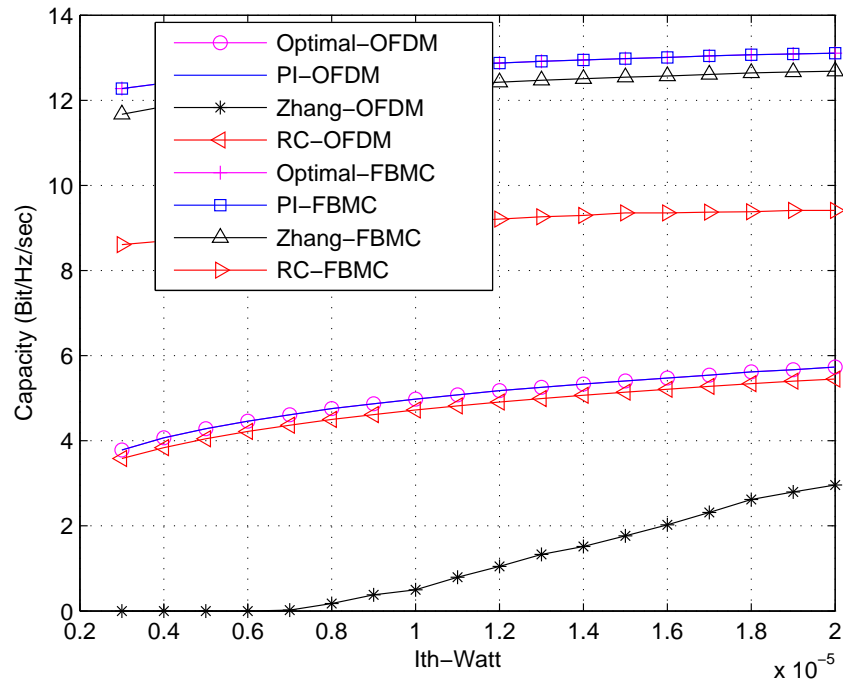


**Figure 3.13:** Frequency distribution with one active PU band.

Fig. 3.14 and Fig. 3.15 show that the proposed *PI-algorithm* performs better than the *RC* and *Zhang* algorithms. In low interference constraints, *RC* algorithm performs better than *Zhang* algorithm because of the limited performance of *Zhang* algorithm in such conditions.



**Figure 3.14:** Achieved capacity vs allowed interference threshold for OFDM and FBMC based CR systems - One active PU band.



**Figure 3.15:** Achieved capacity vs allowed interference threshold (low) for OFDM and FBMC based CR systems - One active PU band.

### 3.6 Chapter Summary and Conclusions

In this chapter, a low complexity sub-optimal resource allocation algorithm for multicarrier based CR networks is presented. Our objective was to maximize the total downlink capacity of the CR network while respecting the available power budget and guaranteeing that no excessive interference is caused to the PUs. The problem is formulated as a combinatorial optimization problem that has an exponential time computational complexity. To reduce the computational complexity, the problem is divided into two steps. In the first step, the different subcarriers are allocated exclusively to the users with the highest channel gain. In the second step, every subcarrier is assumed to belong to the closest PU band and then a convex optimization problem is generated for every PU band in order to evaluate the optimal subcarriers power levels. Multiple Lagrangian multipliers have to be determined in order to find the optimal solution by using any of the numerical methods like interior point or ellipsoid method with  $\mathcal{O}(N^3)$  complexity. To further reduce the computational complexity of the algorithm, an iterative algorithm called *PI-algorithm* is presented. The algorithm consists of four stages. In the first stage, the maximum power that can be allocated to every subcarrier is determined by optimizing subject

to the interference constraints only. Afterwards, the power constraint is tested in the second stage and if it is not satisfied, the third stage is executed to distribute the power budget without exceeding the maximum levels determined on the first stage. Finally, the allocated powers are readjusted in the fourth stage in order to increase the system capacity. With a significant reduction in the computational complexity from  $\mathcal{O}(N^3)$  to  $\mathcal{O}(N \log N) + \mathcal{O}(L)$ , it is shown that the proposed *PI-algorithm* achieves a near optimal performance and outperforms the sub-optimal algorithms proposed so far. It is found that the net total interference introduced to the PUs band is relatively not affected by assuming that each subcarrier belongs to the closest PU band and only introducing interference to it. It is also demonstrated that the capacity of the CR system which uses the non-active as well as the active bands is more than that only uses the non-active bands. Simulation results prove that the FBMC based CR systems have more capacity than OFDM based ones. FBMC offers more spectral efficiency and introduces small interference to the PUs. The significant increase in the capacity of FBMC-based CR systems over the OFDM-based ones recommends the FBMC physical layer as a candidate for the future CR systems.

## 3.A Appendix

### 3.A.1 Derivation of the Optimal Power Allocation Given By Equation (3.12)

We want to find the optimal solution for the following optimization problem

$$\max_{P_i} \sum_{i=1}^N \log_2 \left( 1 + \frac{P_i |h_i|^2}{\sigma_i^2} \right) \quad (3.24)$$

subject to

$$\sum_{i=1}^N P_i \Omega_i^l \leq I_{th}^l \quad \forall l \in \{1, 2, \dots, L\} \quad (3.25)$$

$$\sum_{i=1}^N P_i \leq P_T \quad (3.26)$$

$$P_i \geq 0 \quad \forall i \in \{1, 2, \dots, N\} \quad (3.27)$$

The problem above is a convex optimization problem. The Lagrangian can be written as

$$G = - \sum_{i=1}^N \log_2 \left( 1 + \frac{P_i^* |h_i|^2}{\sigma_i^2} \right) + \sum_{l=1}^L \alpha^l \left( \sum_{i=1}^N P_i^* \Omega_i^l - I_{th}^l \right) + \beta \left( \sum_{i=1}^N P_i^* - P_T \right) - \sum_{i=1}^N P_i^* \mu_i \quad (3.28)$$

where  $\alpha^l, l \in \{1, 2, \dots, L\}$ ,  $\mu_i, i \in \{1, 2, \dots, N\}$ , and  $\beta$  are the Lagrange multipliers. The Karush-Kuhn-Tucker (KKT) conditions can be written as follows

$$\begin{aligned} P_i^* &\geq 0, \forall i \in \{1, 2, \dots, N\} \\ \alpha^l &\geq 0, \forall l \in \{1, 2, \dots, L\} \\ \beta &\geq 0 \\ \mu_i &\geq 0, \forall i \in \{1, 2, \dots, N\} \\ \alpha^l \left( \sum_{i=1}^N P_i^* \Omega_i^l - I_{th}^l \right) &= 0, \forall l \in \{1, 2, \dots, L\} \\ \beta \left( \sum_{i=1}^N P_i^* - P_T \right) &= 0 \\ \mu_i P_i^* &= 0, \forall i \in \{1, 2, \dots, N\} \\ \frac{\partial G}{\partial P_i^*} &= \frac{-1}{\frac{\sigma_i^2}{|h_i|^2} + P_i^*} + \sum_{l=1}^L \alpha^l \Omega_i^l + \beta - \mu_i = 0 \end{aligned} \quad (3.29)$$

Furthermore, the solution should satisfy the total power and interference constraints given by (3.26) and (3.25). Rearranging the last condition in (3.29) we get

$$P_i^* = \frac{1}{\sum_{l=1}^L \alpha^l \Omega_i^l + \beta - \mu_i} - \frac{\sigma_i^2}{|h_i|^2} \quad (3.30)$$

Since  $P_i^* \geq 0$ , we get

$$\frac{\sigma_i^2}{|h_i|^2} \leq \frac{1}{\sum_{l=1}^L \alpha^l \Omega_i^l + \beta - \mu_i} \quad (3.31)$$

If  $\frac{\sigma_i^2}{|h_i|^2} < \frac{1}{\sum_{l=1}^L \alpha^l \Omega_i^l + \beta}$ , then  $\mu_i = 0$  and hence

$$P_i^* = \frac{1}{\sum_{l=1}^L \alpha^l \Omega_i^l + \beta} - \frac{\sigma_i^2}{|h_i|^2} \quad (3.32)$$

Moreover, if  $\frac{\sigma_i^2}{|h_i|^2} > \frac{1}{\sum_{l=1}^L \alpha^l \Omega_i^l + \beta}$ , from (3.30) we get

$$\frac{1}{\sum_{l=1}^L \alpha^l \Omega_i^l + \beta - \mu_i} \geq \frac{\sigma_i^2}{|h_i|^2} \geq \frac{1}{\sum_{l=1}^L \alpha^l \Omega_i^l + \beta} \quad (3.33)$$

and since  $\mu_i P_i^* = 0$  and  $\mu_i \geq 0$ , we get that  $P_i^* = 0$ .

Therefore, the optimal solution can be written as

$$P_i^* = \begin{cases} \frac{1}{\sum_{l=1}^L \alpha^l \Omega_i^l + \beta} - \frac{\sigma_i^2}{|h_i|^2} & \text{if } \frac{\sigma_i^2}{|h_i|^2} < \frac{1}{\sum_{l=1}^L \alpha^l \Omega_i^l + \beta} \\ 0 & \text{if } \frac{\sigma_i^2}{|h_i|^2} \geq \frac{1}{\sum_{l=1}^L \alpha^l \Omega_i^l + \beta} \end{cases} \quad (3.34)$$

or more simply, (3.34) can be; written as the following

$$P_i^* = \left[ \frac{1}{\sum_{l=1}^L \alpha^l \Omega_i^l + \beta} - \frac{\sigma_i^2}{|h_i|^2} \right]^+ \quad (3.35)$$

where  $[x]^+ = \max(0, x)$ .

## Bibliography

- [1] T.J. Willink and P.H. Wittke, "Optimization and performance evaluation of multicarrier transmission," *IEEE Transactions on Information Theory*, vol. 43, no. 2, pp. 426–440, Mar 1997.
- [2] A. Leke and J.M Cioffi, "A maximum rate loading algorithm for discrete multitone modulation systems," in *IEEE Global Telecommunications Conference (GLOBECOM'97)*, 1997, vol. 3, pp. 1514–1518.
- [3] N. Papandreou and T. Antonakopoulos, "Bit and power allocation in constrained multicarrier systems: The single-user case," *EURASIP Journal on Advances in Signal Processing*, vol. 2008, Article ID 643081, 4 pages, 2008.
- [4] J. Jang and K.B. Lee, "Transmit power adaptation for multiuser OFDM systems," *IEEE Journal on Selected Areas in Communications*, vol. 21, no. 2, pp. 171–178, Feb. 2003.
- [5] W. Rhee and J.M. Cioffi, "Increase in capacity of multiuser OFDM system using dynamic subchannel allocation," in *IEEE 51st Vehicular Technology Conference Proceedings, (VTC-Spring 2000)*, Tokyo-Japan, 2000, vol. 2, pp. 1085 –1089.
- [6] Z. Shen, J.G. Andrews, and B.L. Evans, "Adaptive resource allocation in multiuser OFDM systems with proportional rate constraints," *IEEE Transactions on Wireless Communications*, vol. 4, no. 6, pp. 2726 – 2737, Nov. 2005.
- [7] S. Sadr, A. Anpalagan, and K. Raahemifar, "Radio resource allocation algorithms for the downlink of multiuser OFDM communication systems," *IEEE Communications Surveys Tutorials*, vol. 11, no. 3, pp. 92 –106, quarter 2009.
- [8] P. Wang, M. Zhao, L. Xiao, Sh. Zhou, and J. Wang, "Power allocation in OFDM-Based cognitive radio systems," in *IEEE Global Telecommunications Conference (GLOBECOM'07)*, 2007, pp. 4061–4065.
- [9] G. Bansal, M. J. Hossain, and V. K. Bhargava, "Adaptive power loading for OFDM-Based cognitive radio systems," in *IEEE international conference on communication (ICC'07)*, 2007, pp. 5137–5142.

- [10] G. Bansal, M. J. Hossain, and V. K. Bhargava, "Optimal and suboptimal power allocation schemes for OFDM-based cognitive radio systems," *IEEE Transactions on Wireless Communications*, vol. 7, no. 11, pp. 4710–4718, November 2008.
- [11] T. Qin and C. Leung, "Fair adaptive resource allocation for multiuser OFDM cognitive radio systems," in *Second International Conference on Communications and Networking in China (CHINACOM '07)*, Aug. 2007.
- [12] Z. Hasan, G. Bansal, E. Hossain, and V. Bhargava, "Energy-efficient power allocation in OFDM-based cognitive radio systems: A risk-return model," *IEEE Transactions on Wireless Communications*, vol. 8, no. 12, pp. 6078–6088, december 2009.
- [13] P. Setoodeh and S. Haykin, "Robust transmit power control for cognitive radio," *Proceedings of the IEEE*, vol. 97, no. 5, pp. 915–939, May 2009.
- [14] S.M. Almalfouh and G.L. Stuber, "Interference-aware radio resource allocation in OFDMA-Based cognitive radio networks," *IEEE Transactions on Vehicular Technology*, vol. 60, no. 4, pp. 1699–1713, May 2011.
- [15] Y. Zhang and C. Leung, "An efficient power-loading scheme for OFDM-Based cognitive radio systems," *IEEE Transactions on Vehicular Technology*, vol. 59, no. 4, pp. 1858–1864, May 2010.
- [16] G.L. Stuber, S.M. Almalfouh, and D. Sale, "Interference analysis of TV-band whitespace," *Proceedings of the IEEE*, vol. 97, no. 4, pp. 741–754, April 2009.
- [17] R. Zhang, Y-C. Liang, and S. Cui, "Dynamic resource allocation in cognitive radio networks," *IEEE Signal Processing Magazine*, vol. 27, no. 3, pp. 102–114, May 2010.
- [18] B. Farhang-Boroujeny and R. Kempter, "Multicarrier communication techniques for spectrum sensing and communication in cognitive radios," *IEEE Commun. Mag. (Special Issue on Cognitive Radios for Dynamic Spectrum Access)*, vol. 48, no. 4, pp. 80–85, Apr. 2008.
- [19] H. Zhang, D. LE Ruyet, and M. Terre, "On spectral efficiency analysis between OFDM/OQAM and OFDM based CR networks," in *Vehicular Technology Conference (VTC'09-Spring)*, Barcelona-Spain, 2009.

- [20] B. Farhang-Boroujeny, "Filter bank spectrum sensing for cognitive radios," *IEEE Transactions on Signal Processing*, vol. 56, no. 5, pp. 1801–1811, May 2008.
- [21] M. Shaat and F. Bader, "Computationally efficient power allocation algorithm in multicarrier-based cognitive radio networks: OFDM and FBMC systems," *EURASIP Journal on Advances in Signal Processing*, vol. 2010, Article ID 528378, 13 pages, 2010.
- [22] M. Shaat and F. Bader, "Low complexity power loading scheme in cognitive radio networks: FBMC capability," in *IEEE 20th International Symposium on Personal, Indoor and Mobile Radio Communications (PIMRC'09)*, Tokyo-Japan, Sept. 2009.
- [23] M. Shaat and F. Bader, "A two-step resource allocation algorithm in multicarrier based cognitive radio systems," in *IEEE Wireless Communications and Networking Conference (WCNC)*, Sydney-Australia, April 2010, pp. 1–6.
- [24] M. Shaat and F. Bader, "Power allocation with interference constraint in multicarrier based cognitive radio systems," *Book Title: Multi-Carrier Systems and Solutions. Chapter 4: Adaptive Transmission*. Eds. Plass, S.; Dammann, A.; Kaiser, S.; Fazel, K. Springer © 2009. ISBN: 978-90-481-2529-6 (HB). Netherlands.
- [25] M. Shaat and F. Bader, "Power allocation and throughput comparison in OFDM and FBMC based cognitive radio," in *Proceeding of 22nd Meeting of the Wireless World Research Forum (WWRF'09)*, Paris-France, May 2009.
- [26] M. Shaat and F. Bader, "Downlink resource allocation algorithm in OFDM/FBMC cognitive radio networks," in *the 3rd Mosharaka International Conference on Communications, Signals and Coding (MIC-CSC'09)*, Amman-Jordan, Nov. 2009.
- [27] T. Weiss and J. Hillenbrand, "Mutual interference in OFDM-based spectrum pooling systems," in *Vehicular Technology Conference (VTC'04-Spring)*, May 2004, vol. 4.
- [28] A Skrzypczak, P Siohan, and JP Javaudin, "Power spectral density and cubic metric for the OFDM/OQAM modulation," in *IEEE ISSPIT*, Vancouver-Canada, August 2006.
- [29] Leonardo Baltar, Dirk Waldhauser, and Josef Nossek, "Out-of-band radiation in multicarrier systems: A comparison," in *Multi-Carrier Spread Spectrum 2007*, Simon Plass,



Armin Dammann, Stefan Kaiser, and Khaled Fazel, Eds., vol. 1 of *Lecture Notes in Electrical Engineering*, pp. 107–116. Springer Netherlands, 2007.

- [30] M. Bellanger, “Filter banks and OFDM-OQAM for high throughput wireless LAN,” in *3rd International Symposium on Communications, Control and Signal Processing (ISCCSP’08)*, March 2008, pp. 758–761.
- [31] A. Amini, R. Kempter, L. Lin, and B. Farhang-Boroujeny, “Filter bank multitone: a candidate for physical layer of cognitive radio,” in *2005 Software Defined Radio Technical Conference and Product Exhibition (SDR’05)*, Orange County-California, Nov. 2005.
- [32] A. Amini, R. Kempter, and B. Farhang-Boroujeny, “A comparison of alternative filterbank multicarrier methods in cognitive radios,” in *2006 Software Defined Radio Technical Conference and Product Exhibition (SDR’06)*, Orlando-Florida, Nov. 2006.
- [33] Haijian Zhang, Didier Le Ruyet, and Michel Terre, “Spectral efficiency comparison between OFDM/OQAM and OFDM-based CR networks,” *Wireless Communications and Mobile Computing*, 2008.
- [34] M. Guillaud, D.T.M. Slock, and R. Knopp, “A practical method for wireless channel reciprocity exploitation through relative calibration,” in *Proceedings of the Eighth International Symposium on Signal Processing and Its Applications, 2005.*, 2005, vol. 1, pp. 403–406.
- [35] R. Zhang, S. Cui, and Y-C. Liang, “On ergodic sum capacity of fading cognitive multiple-access and broadcast channels,” *IEEE Transactions on Information Theory*, vol. 55, no. 11, pp. 5161–5178, Nov. 2009.
- [36] A.G. Marques, Xin Wang, and G.B. Giannakis, “Dynamic resource management for cognitive radios using limited-Rate feedback,” *IEEE Transactions on Signal Processing*, vol. 57, no. 9, pp. 3651–3666, Sept. 2009.
- [37] Haijian Zhang, D. Le Ruyet, D. Roviras, and Hong Sun, “Capacity analysis of OFDM / FBMC based cognitive radio networks with estimated CSI,” in *Proceedings of the Fifth International Conference on Cognitive Radio Oriented Wireless Networks Communications (CROWNCOM’10)*, June 2010, pp. 1–5.

- [38] A. Punctihewa, V.K. Bhargava, and C. Despins, “Blind estimation of OFDM parameters in cognitive radio networks,” *IEEE Transactions on Wireless Communications*, vol. 10, no. 3, pp. 733–738, March 2011.
- [39] D. Kivanc, G. Li, and H. Liu, “Computationally efficient bandwidth allocation and power control for OFDMA,” *IEEE Transactions on Wireless Communications*, vol. 2, no. 6, pp. 1150–1158, 2003.
- [40] Z. Shen, J. Andrews, and B. Evans, “Optimal power allocation in multiuser OFDM systems,” in *IEEE Global Telecommunications Conference (GLOBECOM’03)*, 2003, vol. 1.
- [41] C. Wong, R. Cheng, K. Lataief, and R. Murch, “Multiuser OFDM with adaptive subcarrier, bit, and power allocation,” *IEEE Journal on Selected Areas in Communications*, vol. 17, no. 10, pp. 1747–1758, 1999.
- [42] S. Boyd and L. Vandenberghe, *Convex optimization*, Cambridge Univ. Press, Cambridge, U.K., 2004.
- [43] Chengshi Zhao and Kyungsup Kwak, “Power/Bit loading in OFDM-Based cognitive networks with comprehensive interference considerations: The single-SU case,” *IEEE Transactions on Vehicular Technology*, vol. 59, no. 4, pp. 1910–1922, May 2010.
- [44] “PHYDYAS-Physical layer for dynamic spectrum access and cognitive radio,” Project website: [www.ict-phydyas.org](http://www.ict-phydyas.org).



# Resource Allocation in Uplink Multicarrier Based Cognitive Radio Systems

*"Each success only buys an admission ticket to a more difficult problem"* **Henry Kissinger.**

## Contents

---

<b>4.1</b>	<b>Introduction</b> . . . . .	<b>104</b>
<b>4.2</b>	<b>System Model and Problem Formulation</b> . . . . .	<b>106</b>
<b>4.3</b>	<b>Proposed Subcarrier and Power Allocation Algorithms (Single PU Case)</b> . . . . .	<b>110</b>
4.3.1	Proposed Subcarrier Allocation Algorithm with Fairness Consideration	111
4.3.2	Proposed Power Allocation Algorithm . . . . .	114
<b>4.4</b>	<b>Generalization of the Proposed Algorithms (Multiple PUs Case)</b> . . . . .	<b>117</b>
<b>4.5</b>	<b>Computational Complexity Analysis</b> . . . . .	<b>121</b>
<b>4.6</b>	<b>Simulation Results</b> . . . . .	<b>122</b>
4.6.1	Case 1: OFDM with Small Number of SUs and Subcarriers . . . . .	123
4.6.2	Case 2: OFDM with High Number of SUs and Subcarriers . . . . .	124
4.6.3	Case 3: OFDM and FBMC with Low/High Number of SUs and Subcarriers . . . . .	129
<b>4.7</b>	<b>Chapter Summary and Conclusions</b> . . . . .	<b>131</b>
<b>4.A</b>	<b>Appendix</b> . . . . .	<b>133</b>
4.A.1	Derivation of the Optimal Power Allocation Given By Equations (4.15) and (4.23) . . . . .	133
	<b>Bibliography</b> . . . . .	<b>135</b>

---

## 4.1 Introduction

By virtue of its flexibility in the allocation of different resources among different users as well as its ability to fill the spectrum holes left by PUs, multicarrier communication systems have been considered as an appropriate candidate for cognitive radio (CR) systems [1,2]. Uncounted research work has been done to find optimal/efficient resource allocation techniques in conventional (non-cognitive) multicarrier systems. As described in chapter 3, in non-cognitive downlink scenario (see, e.g. [3–7] and references therein), the maximum throughput can be achieved by allocating each subcarrier to the user with the maximum signal to noise ratio (SNR) and then distributing the power according to waterfilling solution. Additionally, many algorithms to solve resource allocation problem in uplink non-cognitive systems have been proposed (see, e.g. [8–11] and references therein). In [10], Kim et al. proposed a greedy subcarrier allocation algorithm based on marginal rate function and iterative waterfilling power allocation algorithm. This algorithm is developed in [11] to consider fairness among different users. The algorithms used in non-cognitive multicarrier systems are not efficient in CR ones due to the existence of the interference temperature constraints.

For single channel (carrier) CR systems, the optimal resource allocation schemes in uplink and downlink have been presented for both single and multiuser systems (see, e.g. [12–16]). In multicarrier based CR systems, the downlink scenario has been addressed well recently (see, e.g. [2, 17–21]), while less existed research on subcarrier and power allocation in the uplink one [22–28].

In [23] and [28], game theory based approaches has been applied. In the former [23], a network-assisted resource allocation problem is modeled and analyzed using cooperative game theory. Both the primary users (PUs) and the secondary users (SUs) inform the primary base station (BS) of their channel state information (CSI) and the primary BS utilize this information to perform the allocation [23]. In the latter [28], a joint resource allocation algorithm is developed to achieve a good trade-off between the fairness and efficiency [28]. A competitive fairness among users is enforced based on Blotto game [29]. In Blotto game, the SUs are tasked to distribute their limited power budgets over several subcarriers while taking into consideration the interference introduced to the PUs. The user who is allocating the most resources to a certain subcarrier wins the subcarrier. Therefore, the SUs need to allocate their budget judiciously to win as many good subcarriers as possible. In [22], Fadel proposed an

algorithm for jointly allocating channels and powers among different users under individual user's power constraints. The problem is relaxed to obtain a convex version. Then, the solution is quantized to yield a binary channel allocation. Afterwards, the solution is modified to consider the constraints on the in-band interference to the licensed system. Wang et al. proposed in [24] an algorithm to allocate resources in uplink OFDMA based CR systems under per subcarrier power constraints (in-band interference constraints). Subcarriers are allocated initially to the users with the best channel quality and then adjusted according to different user's waterfilling levels. The algorithm has high computational complexity and limited performance. In [25], Zhang et al. proposed a resource allocation algorithm in which subcarrier assignment and power allocation are carried out sequentially under mutual interference and per user power constraints. The proposed scheme requires pre-knowledge about the number of subcarriers that should be allocated to each user as well as the capacity that can be achieved by each subcarrier. The power allocation was performed using the gradient projection algorithm. Nam et al. proposed in [26] a location-based low-complexity algorithms which use the relative location information between PUs and SUs to estimate the interference. The imperfect sensing errors are considered in [27]. The authors determine the initial power levels according to different criteria, then formulate the subcarrier allocation part as a generalized assignment problem (GAP). Instantaneous fairness among users was not taken into consideration in the algorithms previously mentioned in [22, 24–27].

In [30], the mutual interference between PU and SU was studied. The mutual interference depends on the transmitted power as well as the spectral distance between PUs and SUs. OFDM based CR system suffers from high interference to the PUs due to large sidelobes of its filter frequency response. Moreover, the insertion of the cyclic prefix (CP) in each OFDM symbol decreases the system capacity. Filter bank multicarrier system (FBMC) with the offset quadrature amplitude modulation (OQAM) can achieve smaller intersymbol interference (ISI) and intercarrier interference (ICI) without using the CP by utilizing well designed pulse shapes that satisfy the perfect reconstruction conditions. Moreover, the problem of the spectral leakage can be solved by minimizing the sidelobes of each subcarrier which leads to high efficiency (in terms of spectrum and interference) [25, 31].

In this chapter, an efficient resource allocation algorithm in uplink OFDM-based CR systems is proposed. The scenario in which the SUs are transmitting on the unused PU bands and causing interference to the active ones is considered. The objective is to maximize the capacity

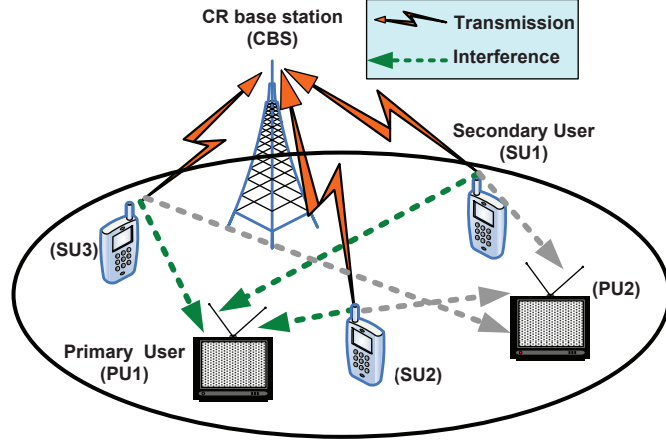
while respecting the per-user power constraints and guaranteeing that no excessive interference is induced to the PUs. The chapter contributions are summarized in the following points:

- As the resource allocation algorithm is a mixed-integer optimization problem, we proposed an efficient algorithm that reduces the computational complexity by separating the subcarrier and power allocation processes into two different steps. The proposed algorithm is shown to have a near-optimal performance and outperforms the algorithms presented in [22, 24]. Additionally, the performance of the algorithm used in non-cognitive multicarrier systems is discussed.
- Different from the algorithms developed in [22, 24], the fairness among users is considered within the subcarrier allocation by reducing the probability of having users whose instantaneous rate is below the minimum required value.
- The efficiency of the proposed algorithm is investigated for OFDM and FBMC based systems to show the capability of using FBMC in the cognitive networks.

The contents of this chapter have been partially published in references [32–35]. This chapter is organized as follows: Section 4.2 introduces the system model and formulates the problem. The proposed algorithm for single PU is presented in Section 4.3, and then generalized for multiple PUs in Section 4.4. The computational complexity of the algorithm is discussed in Section 4.5 while selected numerical results are presented in Section 4.6. Finally, Section 4.7 summarizes and concludes the chapter.

## 4.2 System Model and Problem Formulation

In this chapter, the PUs and SUs are co-existing in the same geographical location as described in Fig.4.1. For the CR system, uplink transmission will be assumed in which SUs are opportunistically accessing the unused PU bands and transmitting to their cognitive base station (CBS) without causing harmful interference to PUs. As shown in Fig.4.2, the frequency bands  $B_1, B_2, \dots, B_L$  represent the  $L$  active PU bands while the non-active bands represent the bands that can be used by CR system (CR band). The CR band is divided into  $N$  subcarriers each having a  $\Delta f$  bandwidth. There is no synchronization between the primary and secondary sys-



**Figure 4.1:** Uplink Cognitive Radio Network.

tems. The interference induced to the  $l^{th}$  PU band should not exceed the predefined interference temperature limit  $I_{th}^l$ .

Assume that  $\Phi_i(f)$  is the power spectral density (PSD) of the  $i^{th}$  subcarrier. The expression of the PSD depends on the used multicarrier technique. If an OFDM based CR is assumed, the PSD of the  $i^{th}$  subcarrier can be written as

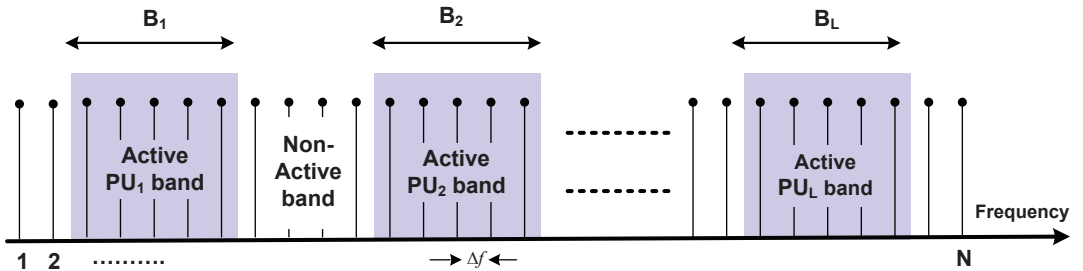
$$\Phi_i(f) = |G_i(f)|^2 \quad (4.1)$$

where  $|G_i(f)|^2$  is the Fourier transform of the used pulse shape  $g_T$ . Assuming a rectangular pulse with length  $T_s = N + C$  where  $N$  is the number of subcarriers (IDFT size) and  $C$  is the length of the CP,  $|G_i(f)|^2$  can be expressed as follows

$$|G_i(f)|^2 = T_s + 2 \sum_{r=1}^{T_s-1} (T_s - r) \cos(2\pi fr) \quad (4.2)$$

If FBMC based CR system is assumed, the PSD of the  $i^{th}$  subcarrier can be written as

$$\Phi_i(f) = |H_i(f)|^2 \quad (4.3)$$



**Figure 4.2:** Frequency distribution of active and non-active primary bands.



where  $|H_i(f)|$  is the frequency response of the prototype filter with coefficients  $h[n]$  with  $n \in \{0, \dots, W-1\}$ , where  $W = KN$  and  $K$  is the length of each polyphase component (overlapping factor). Assuming that the prototype coefficients have even symmetry around the  $(\frac{KN}{2})^{th}$  coefficient, and the first coefficient is zero [36], we get

$$|H_i(f)| = h[W/2] + 2 \sum_{r=1}^{\frac{W}{2}-1} h[(W/2) - r] \cos(2\pi fr) \quad (4.4)$$

The interference  $I_{i,m}^l(d_i^l, P_{i,m})$  introduced by the transmission of the  $i^{th}$  subcarrier of the Cr system -which is allocated to the  $m^{th}$  SU- to the  $l^{th}$  PU band is the integration of the PSD of the  $i^{th}$  subcarrier across the  $l^{th}$  PU band, and can be expressed as [30]

$$I_{i,m}^l(d_i^l, P_{i,m}) = P_{i,m} \Omega_{i,m}^l; \quad \Omega_{i,m}^l = \int_{d_i^l - B_l/2}^{d_i^l + B_l/2} |g_{i,m}^l|^2 \Phi_i(f) df \quad (4.5)$$

where  $d_i^l$  is the spectral distance between the  $i^{th}$  subcarrier and the  $l^{th}$  PU band.  $g_{i,m}^l$  denotes the channel gain -may include path loss and shadowing part- between the  $i^{th}$  subcarrier and the  $l^{th}$  PU band while  $P_{i,m}$  is the total transmit power emitted by the  $i^{th}$  subcarrier.  $\Omega_{i,m}^l$  denotes the interference factor of the  $i^{th}$  subcarrier to the  $l^{th}$  PU band.  $B_l$  is the bandwidth of the PU band. The subscript  $m$  denotes the case when the  $i^{th}$  subcarrier is allocated to the  $m^{th}$  SU. Similarly, the interference power introduced by the  $l^{th}$  PU signal into the band of the  $i^{th}$  subcarrier is [30]

$$J_{i,m}^l = \int_{d_i^l - \Delta f/2}^{d_i^l + \Delta f/2} |y_{i,m}^l|^2 \psi_l(e^{j\omega}) d\omega \quad (4.6)$$

where  $\psi_l(e^{j\omega})$  is the PSD of the  $l^{th}$  PU signal and  $y_{i,m}^l$  is the channel gain between the  $i^{th}$  subcarrier and  $l^{th}$  PU signal.

The maximum achievable transmission rate of the  $i^{th}$  subcarrier,  $R_i$  can be evaluated by

$$R_i(P_{i,m}, h_{i,m}) = \Delta f \log_2 \left( 1 + \frac{P_{i,m} |h_{i,m}|^2}{\sigma_i^2} \right) \quad (4.7)$$

where  $P_{i,m}$  is the transmission power and  $h_{i,m}$  is the  $i^{th}$  subcarrier fading gain from the  $m^{th}$  SU to the CBS. Additionally,  $\sigma_i^2 = \sigma_{AWGN}^2 + \sum_{l=1}^L J_i^l$  where  $\sigma_{AWGN}^2$  is the variance of the additive white Gaussian noise (AWGN) and  $J_i^l$  is the interference introduced by the  $l^{th}$  PU band into the  $i^{th}$  subcarrier which is evaluated using (4.6) and can be modeled as AWGN as described in [2]. Throughout this chapter, all the instantaneous fading gains are assumed to be perfectly

known at the CBS. Practically, the channel gains between SUs and the CBS can be obtained by classical channel estimation techniques while the channel gains between SUs and PUs can be obtained by estimating the received signal power from each primary terminal when it transmits, under the assumptions of pre-knowledge on the primary transmit power levels and the channel reciprocity [16, 37]. Based on the channel gains, the CBS assigns the subcarriers and powers to each SU through a reliable low-rate signaling channel.

It is assumed that each subcarrier can be used for transmission to at most one user at any given time. Fairness among SUs is guaranteed by assuming that every SU has a minimum instantaneous rate  $R_{min}$ . Our objective is to maximize the total data rate of the CR system subject to the constraints on the interference introduced to the PUs, the per-user transmit power constraints and the per-user minimum rate constraints. Therefore, the optimization problem can be formulated as follows

$$\begin{aligned}
 P1 : \quad & \max_{P_{i,m}, v_{i,m}} \sum_{m=1}^M \sum_{i=1}^N v_{i,m} R_i(P_{i,m}, h_{i,m}) \\
 s.t. \quad & \sum_{m=1}^M \sum_{i=1}^N v_{i,m} P_{i,m} \Omega_{i,m}^l \leq I_{th}^l \quad \forall l \in \{1, \dots, L\} \\
 & \sum_{i=1}^N v_{i,m} P_{i,m} \leq \overline{P}_m, \quad \forall m \\
 & P_{i,m} \geq 0, \quad \forall i, m \\
 & v_{i,m} \in \{0, 1\}, \quad \forall i, m \\
 & \sum_{m=1}^M v_{i,m} \leq 1, \quad \forall i \\
 & \sum_{i=1}^N v_{i,m} R_i(P_{i,m}, h_{i,m}) \geq R_{min}, \quad \forall m
 \end{aligned} \tag{4.8}$$

where  $N$  denotes the total number of subcarriers while  $M$  denotes the number of SUs.  $v_{i,m}$  is the subcarrier allocation indicator, i.e.  $v_{i,m} = 1$  if and only if the  $i^{th}$  subcarrier is allocated to the  $m^{th}$  user.  $L$  is the number of active PU bands and  $I_{th}^l$  is the interference threshold prescribed by the  $l^{th}$  PU.  $\overline{P}_m$  is the  $m^{th}$  SU total power budget. Without loss of generality, the minimum instantaneous rate  $R_{min}$  is assumed constant for all users. The solution can be easily extended to consider different minimum instantaneous rates for the different SUs. The CBS performs the subcarrier and power allocation and then diffuse the result to the different SUs.

The optimization problem  $P1$  is a mixed-integer optimization problem; in which achieving the optimal solution needs high computational complexity. Additionally, the minimum rate constraints increase the complexity of the problem. In order to solve the problem, an algorithm to perform the resource allocation in two steps is proposed. In the first step, a heuristic

sub-optimal algorithm is used to allocate the subcarriers to the different users. Afterwards, the optimal power allocation is evaluated in the second step. The optimal power allocation algorithm requires high computational complexity. Thus, a low complexity power algorithm is proposed to perform the power allocation step. Depending on the values of the constraints and the channel gains, the CR system may not be able to satisfy the minimum rate  $R_{min}$  for all the users. Therefore, the last constraint in the optimization problem  $P1$  is relaxed by reducing the probability of having users whose rates are below the minimum rate. The outage probability can be defined as

$$P_{outage} = Pr\{M_{low} \geq 1\} \quad (4.9)$$

where  $M_{low}$  is the number of SUs whose instantaneous rate are below  $R_{min}$ .

The proposed algorithm is discussed in the next section. For sake of description clarity, the single PU case is firstly explained then, the solution is generalized for multiple PUs case.

### 4.3 Proposed Subcarrier and Power Allocation Algorithms (Single PU Case)

The optimal downlink subcarrier to users allocation scheme in cognitive and non-cognitive multicarrier systems is achieved by allocating each subcarrier to the user with the maximum signal to noise ratio (SNR) [4–7]. This scheme of subcarrier allocation is inefficient in the uplink case due to the per-user power constraints. Moreover, the interference introduced to the primary system by each SU should be considered in CR context which makes the schemes used in classical multicarrier systems inefficient. In this section, a heuristic subcarrier and power allocation algorithm is presented. For better description of the proposed algorithm, only one PU band, i.e. single interference constraint, is considered in this section. The solution is generalized in the next section to consider multiple interference constraints. We refer to the single interference constraint by  $I_{th}^{l*}$  and hence, the first constraint in the optimization problem  $P1$  can be rewritten as follows

$$\sum_{m=1}^M \sum_{i=1}^N v_{i,m} P_{i,m} \Omega_{i,m}^{l*} \leq I_{th}^{l*} \quad (4.10)$$

where  $\Omega_{i,m}^{l*}$  denotes the interference factor of the  $i^{th}$  subcarrier to the PU band ( $l^*$ ) when the  $i^{th}$  subcarrier is allocated to  $m^{th}$  SU. In the sequel, the proposed subcarrier to user assign-

ment scheme with low outage probability is introduced, and then an efficient power allocation algorithm is presented.

### 4.3.1 Proposed Subcarrier Allocation Algorithm with Fairness Consideration

To achieve an efficient subcarrier allocation, the proposed algorithm should assign the subcarriers to different SUs considering not only their channel quality and per-user power constraints but considering also the induced interference to the PU band. Moreover, the probability of having users with instantaneous rates below the minimum rate should be reduced.

The scheme assumes that the interference introduced to the primary system, i.e.  $I_{th}^{l*}$ , is divided uniformly among the different subcarriers [2]. Accordingly, the maximum amount of interference,  $I_{Uniform}^{l*}$ , that can be introduced by any subcarrier is

$$I_{Uniform}^{l*} = \frac{I_{th}^{l*}}{N} \quad (4.11)$$

Using (4.5), the maximum power,  $P_{i,m}^{Uni}$ , that can be allocated to the  $i^{th}$  subcarrier when it is allocated to the  $m^{th}$  SU is

$$P_{i,m}^{Uni} = \frac{I_{Uniform}^{l*}}{\Omega_{i,m}^{l*}} \quad (4.12)$$

Let us define the following sets

- $\mathcal{C}$  : the set of unassigned subcarriers.
- $\mathcal{U}$  : the set that contains the indices of the users whose rates are below  $R_{min}$ .
- $\mathcal{A}_m$  : the set that includes the subcarriers already allocated to the  $m^{th}$  user with powers equal to the maximum power  $P_{i,m}^{Uni}$ .
- $\mathcal{B}_m$  : the set that includes the subcarriers already allocated to the  $m^{th}$  user with powers equal to the average power. The average power means here that the remaining power for the  $m^{th}$  user after allocating the powers to the subcarriers in  $\mathcal{A}_m$  is divided equally among the subcarriers in the set  $\mathcal{B}_m$ , i.e.  $P_m^{avg} = \frac{\bar{P}_m - \sum_{x \in \mathcal{A}_m} P_{x,m}^{Uni}}{|\mathcal{B}_m|}$  where  $|\mathcal{B}_m|$  means the cardinality of the set  $\mathcal{B}_m$ .

According to the previous definition, the instantaneous rate of the  $m^{th}$  user,  $R(m, \mathcal{A}_m, \mathcal{B}_m)$ , is the summation of the rates of the subcarriers in the sets  $\mathcal{A}_m$  and  $\mathcal{B}_m$  and is given by

$$R(m, \mathcal{A}_m, \mathcal{B}_m) = \sum_{i \in \mathcal{A}_m} R_i(P_{i,m}^{Uni}, h_{i,m}) + \sum_{i \in \mathcal{B}_m} R_i(P_m^{avg}, h_{i,m}) \quad (4.13)$$

where  $R_i(P_{i,m}, h_{i,m})$  is evaluated using (4.7). Note that the allocated powers according to either the maximum or the average power are only used to simplify the calculation of the increment in the data rate. The optimal power allocation will be derived later based on the subcarrier allocation information.

The algorithm commences by allocating the subcarriers that are located next to the PU band, i.e. subcarriers that may have more interference to the PU, and moving towards the distant ones. The subcarriers are allocated sequentially to the users until all the subcarriers are assigned. In order to reduce the probability of having users whose rates are below the minimum value, the allocation of the subcarriers will be confined within the users in the set  $\mathcal{U}$ . Initially the set  $\mathcal{U}$  is assumed to contain all SUs. Throughout the allocation of the different subcarriers, if the rate of the  $m^{th}$  user becomes more than the minimum required rate  $R_{min}$ , the user is removed from the set  $\mathcal{U}$ . If the minimum rate constraints are satisfied for all the users, i.e.  $\mathcal{U}$  is empty, the subcarrier can be allocated to any one of the SUs. If the optimization problem is assumed to be solved without any minimum rate constraints, the set  $\mathcal{U}$  is assumed always empty. Accordingly, the subcarrier can be allocated to any one of the SUs. It is worth mentioning that the subcarriers with high interference gains will potentially have a low transmitting power even when they have a good channel quality. Therefore, the limitation that will be introduced to any subcarrier assignment due the interference constraints should be considered and the subcarriers should be classified according to their interference gains. To allocate a given subcarrier, the algorithm initially assigns the subcarrier to the set  $\mathcal{B}_m$  and evaluates new average power,  $P_{Test}$ . If the average power exceeds the maximum power, i.e.  $P_{Test} \geq P_{i,m}^{Uni}$ , then the subcarrier should be moved to the set  $\mathcal{A}_m$ . Afterwards, the increments of the individual data rates due to the allocation of a particular subcarrier to different SUs are evaluated and the subcarrier is allocated to the SU with maximum data rate increment. The scheme is repeated until the allocation of all subcarriers. Note that the final set of allocated subcarriers to  $m^{th}$  SU is  $\mathcal{N}_m = \mathcal{A}_m \cup \mathcal{B}_m$ . By assuming initially that  $\mathcal{U} = \{1, \dots, M\}$ , and both sets  $\mathcal{A}_m$  and  $\mathcal{B}_m$  are empty sets, the assigning procedures of a particular subcarrier  $i^* \in \mathcal{C}$  are described in Algorithm 4.4.

---

**Algorithm 4.4** Subcarrier to User Allocation

---

1.  $\forall m \in \mathcal{U}$ ,  
 Evaluate  $P_{Test} = \frac{\overline{P}_m - \sum_{r \in \mathcal{A}_m} P_{r,m}^{Uni}}{|\mathcal{B}_m|+1}$   
**if**  $P_{Test} \geq P_{i^*,m}^{Uni}$   
 let  $\mathcal{A}_m^* = \mathcal{A}_m \cup \{i^*\}$  and  $\mathcal{B}_m^* = \mathcal{B}_m$   
**else** let  $\mathcal{B}_m^* = \mathcal{B}_m \cup \{i^*\}$  and  $\mathcal{A}_m^* = \mathcal{A}_m$ .
2. Compute the amount of increment  $\Delta_m$  in the data rate when the subcarrier  $\{i^*\}$  is assigned to  $m^{th}$  SU, i.e.,

$$\Delta_m = R_m^{new} - R_m^{old} = R(m, \mathcal{A}_m^*, \mathcal{B}_m^*) - R(m, \mathcal{A}_m, \mathcal{B}_m)$$

where  $R(m, \mathcal{A}_m^*, \mathcal{B}_m^*)$  and  $R(m, \mathcal{A}_m, \mathcal{B}_m)$  are evaluated using (4.13).

3. Find  $m^*$  satisfying  $m^* = \arg \max_m (\Delta_m)$ , set  $v_{i^*,m^*} = 1$ , and update the sets  $\mathcal{A}_{m^*} = \mathcal{A}_{m^*}^*$  and  $\mathcal{B}_{m^*} = \mathcal{B}_{m^*}^*$ .
  4. If  $R(m^*, \mathcal{A}_{m^*}, \mathcal{B}_{m^*}) \geq R_{min}$ , remove  $m^*$  from the set  $\mathcal{U}$ . If  $\mathcal{U}$  is empty, let  $\mathcal{U} = \{1, \dots, M\}$ .
  5. Remove the subcarrier  $i^*$  from the set  $\mathcal{C}$ .
-

### 4.3.2 Proposed Power Allocation Algorithm

By the subcarrier to users assignment step, the subcarriers are allocated to different users with the consideration of minimum rates constraints. Therefore, the values of the subcarriers indicators, i.e.  $v_{i,m}$ , are already known from the previous step. The multiuser system can be viewed virtually as a single user multicarrier system and the power allocation problem can be formulated as follows

$$\begin{aligned}
 P2 : \quad & \max_{P_{i,m}} \sum_{i=1}^N R_i(P_{i,m}, h_{i,m}) \\
 \text{s.t.} \quad & \sum_{i=1}^N P_{i,m} \Omega_{i,m}^{l*} \leq I_{th}^{l*} \\
 & \sum_{i \in \mathcal{N}_m} P_{i,m} \leq \overline{P}_m \quad \forall m \\
 & P_{i,m} \geq 0 \quad \forall i
 \end{aligned} \tag{4.14}$$

where  $m$  refers to the user who has already got the subcarrier  $i$ , i.e.  $v_{i,m} = 1$ .  $\mathcal{N}_m$  denotes the set of subcarriers allocated to the  $m^{\text{th}}$  SU. Remark that having too much power in relative with the interference constraint leads to an interference-only optimization problem while having high interference constraint in relative with the total power leads to non-cognitive (classical) resource allocation problem.

The problem  $P2$  is a convex optimization problem. Solving for the optimal solution (See Appendix 4.A.1 for the derivation), one gets

$$P_{i,m}^* = \left[ \frac{1}{\alpha^{l*} \Omega_{i,m}^{l*} + \beta_m} - \frac{\sigma_i^2}{|h_{i,m}|^2} \right]^+ \tag{4.15}$$

where  $\alpha^{l*}$  and  $\beta_m$  are the non-negative Lagrange multipliers and  $[x]^+ = \max(0, x)$ . Solving for  $(M + 1)$  Lagrangian multipliers is computational complex. The optimal solution can be found numerically using ellipsoid or interior point method with a complexity  $\mathcal{O}(N^3)$  [38]. The high computational complexity makes the optimal solution unsuitable for practical application and hence a low complexity algorithm is proposed.

On one side, ignoring the interference constraint in problem  $P2$  lets the optimal solution to be the distribution of the per-user power budget  $\overline{P}_m$  among the set of subcarriers  $\mathcal{N}_m$  according to the well known waterfilling solution [39]. On the other side, if the per-user power constraints are ignored, the analysis given in [2] can be followed where the Lagrangian of the problem (4.14) can be written as

$$G^{(Int)}(l^*) = - \sum_{i=1}^N R_i(P_{i,m}^{(Int)}, h_{i,m}) + \gamma_{l^*}^{(Int)} \left( \sum_{i=1}^N P_{i,m}^{(Int)} \Omega_{i,m}^{l*} - I_{th}^{l*} \right) \tag{4.16}$$

where  $\gamma_{l^*}^{(Int)}$  is the Lagrange multiplier.  $(Int)$  stands for optimization under the interference constraint only. Equating  $\frac{\partial G^{(Int)}(l^*)}{\partial P_{i,m}^{(Int)}}$  to zero, we get

$$P_{i,m}^{(Int)}(l^*) = \left[ \frac{1}{\gamma_{l^*}^{(Int)} \Omega_{i,m}^{l^*}} - \frac{\sigma_i^2}{|h_{i,m}|^2} \right]^+ \quad (4.17)$$

Hence, substituting (4.17) into  $\sum_{i=1}^N P_{i,m}^{(Int)} \Omega_{i,m}^{l^*} = I_{th}^{l^*}$  we get

$$\gamma_{l^*}^{(Int)} = \frac{|N|}{I_{th}^{l^*} + \sum_{i=1}^N \frac{\Omega_{i,m}^{l^*} \sigma_i^2}{|h_{i,m}|^2}} \quad (4.18)$$

One can note that if the solution found by (4.17) and (4.18) satisfies the different per-user power constraints, i.e.  $\sum_{i \in \mathcal{N}_m} P_{i,m}^{(Int)}(l^*) \leq \overline{P}_m, \forall m$ , then (4.17) and (4.18) is composing the optimal solution for the optimization problem  $P2$  where the case of interference-only optimization problem occurred. In most of the cases, this relation doesn't hold which motivates developing an efficient algorithm considering both the interference and per-user power constraints.

In the previous chapter, we dealt with the downlink power allocation problem considering one total power constraint. The *PI-algorithm* presented in the previous chapter is extended here to consider the uplink scenario with several per-user power constraints. The power allocation step is performed throughout the following stages:

- **Maximum power determination:** assume that the maximum power,  $P_{i,m}^{Max}$ , that can be allocated to each subcarrier is determined according to the interference constraint only using (4.17) and (4.18), i.e.  $P_{i,m}^{Max} = P_{i,m}^{(Int)}(l^*)$ .
- **Power constraints testing:** test the per-user power constraints to check whether the relation  $\sum_{i \in \mathcal{N}_m} P_{i,m}^{(Int)}(l^*) \leq \overline{P}_m, \forall m$  holds or not. If the relation is satisfied, then the solution is found where  $P_{i,m}^* = P_{i,m}^{Max}$ . Otherwise, continue.
- **Power budgets distribution:** the available power  $\overline{P}_m$  for each SU should be distributed among the subcarriers in  $\mathcal{N}_m$  given that the power allocated to each subcarrier is lower than or equal to  $P_{i,m}^{Max}$ . For every SU, the following problem should be solved

$$\begin{aligned} P3 : \quad & \max_{P_{i,m}^{W.F}} \sum_{i \in \mathcal{N}_m} R_i(P_{i,m}^{W.F}, h_{i,m}) \\ s.t. \quad & \sum_{i \in \mathcal{N}_m} P_{i,m}^{W.F} \leq \overline{P}_m; \\ & 0 \leq P_{i,m}^{W.F} \leq P_{i,m}^{Max} \end{aligned} \quad (4.19)$$



The problem  $P3$  is called "cap-limited" waterfilling [40, 41] where  $P_{i,m}^{W.F}$  is the cap-limited waterfilling allocated power. More detailed description about the "cap-limited" waterfilling can be found in Section 3.4.

- **Power levels re-adjustment:** the solution  $P_{i,m}^{W.F}$  of the problem  $P3$  satisfies the per-user power constraints of the problem  $P2$  with equality which is not the case for the interference constraint  $I_{th}^*$ . Due to that, some of the powers allocated to subcarriers is not reach the maximum allowable values which makes the interference introduced to the primary system below the threshold  $I_{th}^*$ . In order to take the advantage of the allowable interference, some amount of power can be taken from one subcarrier and given to another; hoping to increase the total system capacity. Therefore, the values of the maximum power that can be allocated to each subcarrier  $P_{i,m}^{Max}$  should be updated depending on the remaining interference. The residual interference can be determined as follows

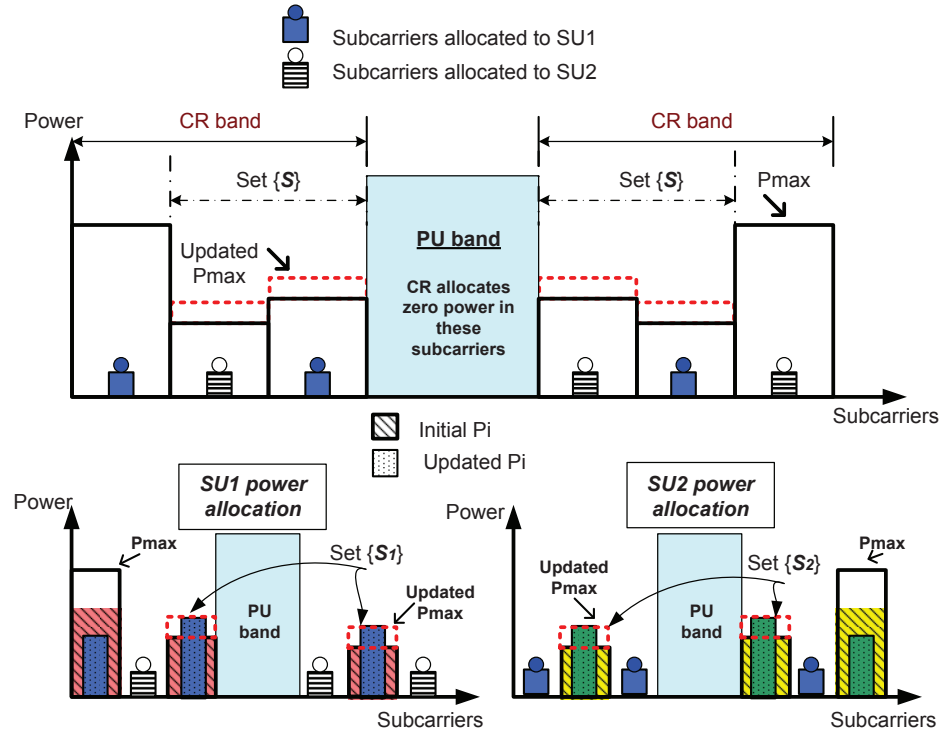
$$I_{Residual}^{l*} = I_{th}^{l*} - \sum_{i=1}^N P_{i,m}^{W.F} \Omega_{i,m}^{l*} \quad (4.20)$$

Assuming that  $\mathcal{S}_m \subset \mathcal{N}_m$  is the set of the subcarriers that reach its maximum, i.e.  $P_{i,m}^{W.F} = P_{i,m}^{Max}, \forall i \in \mathcal{S}_m$ , then,  $P_{i,m}^{Max}, \forall i \in \mathcal{S}_m$  can be updated by applying the equations (4.17)-(4.18) on the subcarriers in the set  $\mathcal{S} = \{S_1 \cup S_2 \cdots \cup S_m\}$  with the following interference constraint

$$I_{updated}^{l*} = I_{Residual}^{l*} + \sum_{i \in \mathcal{S}} P_{i,m}^{W.F} \Omega_{i,m}^{l*} \quad (4.21)$$

After determining the updated values of  $P_{i,m}^{Max}$ , the "cap-limited" waterfilling is performed again for every SU to find the final solution  $P_{i,m}^* = P_{i,m}^{W.F}$ .

A graphical description of the proposed power allocation algorithm is given in Fig. 4.3 where the subcarriers are distributed between two SUs, named SU1 and SU2. Two levels of allocation are performed, the upper one is performed on a global way while the lower ones are performed on an individual (per user) way. In the global level, the interference constraint is considered where the interference is accumulated by all subcarriers while the power constraints are considered in the lower level where the different users distribute the powers among their allocated subcarriers. The algorithm starts by determining the maximum powers that can be allocated to each subcarrier. Afterwards, every SU distributes the power budget on its own



**Figure 4.3:** Example of the SUs allocated power using proposed power allocation algorithm.

subcarriers considering the pre-specified maximum powers. Thereafter, the allocation process returns back to the global level to update the maximum power according to the residual interference. Finally, the per-user power is allocated on different subcarriers considering the updated maximum values.

## 4.4 Generalization of the Proposed Algorithms (Multiple PUs Case)

The algorithm presented in the Section 4.3 to solve the optimization problem  $P1$  considering only one interference constraint is generalized in this section to consider  $L$  interference constraints, i.e. multiple PU bands. In the previous chapter, we assumed that the CR can induce interference to the primary bands slightly more than the value of the interference constraint. This simplifies the original problem by assuming that the subcarrier belongs to the closest PU band and introducing interference to it only. The numerical simulations show that this assumption is reasonable. In this chapter, a more restrictive primary system is assumed where no violation of the interference constraints is allowed. This type of restriction is considered in the

generalization of the subcarrier and power allocation algorithms by selecting always the power that generates the minimum interference to the PU bands.

For the subcarrier allocation step, considering the same assumption in which every subcarrier is able to introduce the same amount of interference to the different PU bands, the value of the maximum power that can be allocated to each subcarrier, i.e.  $P_{i,m}^{Uni}$ , is determined by choosing the minimum among the different maximum powers evaluated according to the different interference constraints. Therefore, equation (4.12) can be generalized as follows

$$P_{i,m}^{Uni} = \min \left\{ \frac{I_{Uniform}^1}{\Omega_{i,m}^1}, \frac{I_{Uniform}^2}{\Omega_{i,m}^2}, \dots, \frac{I_{Uniform}^L}{\Omega_{i,m}^L} \right\} \quad (4.22)$$

Once the maximum power  $P_{i,m}^{Uni}$  is determined, the same subcarrier assigning procedures presented previously can be used for the multiple PU bands case.

In the power allocation step, if multiple interference constraints are considered in the optimization problem  $P2$ , the solution given in (4.15) can be generalized as follows

$$P_{i,m}^* = \left[ \frac{1}{\sum_{l=1}^L \alpha^l \Omega_{i,m}^l + \beta_m} - \frac{\sigma_i^2}{|h_{i,m}|^2} \right]^+ \quad (4.23)$$

where  $\alpha^l$  and  $\beta_m$  are the non-negative Lagrange multipliers. Therefore, the problem becomes more computationally complex where  $(M + L)$  Lagrangian multipliers should be determined. To find a suboptimal solution for the multiple PUs case, the values of the allocated power  $P_{i,m}^{(Int)}(l)$  under every interference constraint  $I_{th}^l$  are determined using (4.17) and (4.18). Then, the maximum power  $P_{i,m}^{Max}$  that can be allocated to each subcarrier is determined according to the following formula

$$P_{i,m}^{Max} = \min \{ P_{i,m}^{(Int)}(1), P_{i,m}^{(Int)}(2), \dots, P_{i,m}^{(Int)}(L) \} \quad (4.24)$$

Afterwards, the per-user power constraints are tested and the "cap-limited" waterfilling is applied for every user  $m$ . Using (4.20) and (4.21), the updated values of the interference thresholds can be found. Afterwards, (4.17) and (4.18) are applied to find the values of  $P_{i,m}^{(Int)}(l) \forall i \in \mathcal{S}$ . Accordingly, the new values of  $P_{i,m}^{Max}$  can be determined using (4.24). The "cap-limited" waterfilling is performed again for every SU considering the updated maximum values to find the final solution. The flowcharts of the generalized power allocation algorithm is given in Fig. 4.4 and detailed in Algorithm 4.5.

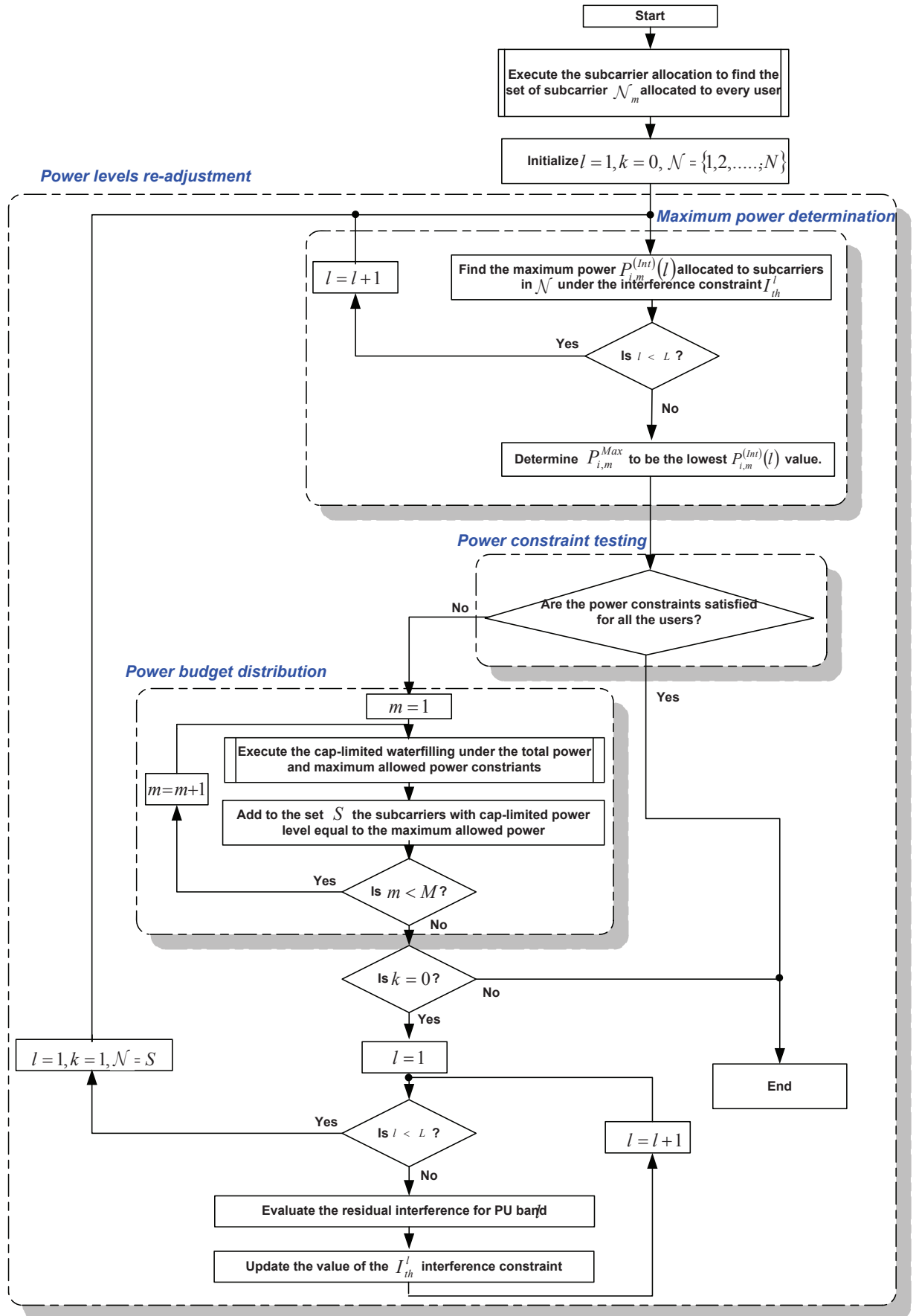


Figure 4.4: Flowchart of the proposed power allocation algorithm.

---

**Algorithm 4.5** Power Allocation Algorithm
 

---

1. **Initialize**  $\mathcal{N} = \{1, 2, \dots, N\}$ ,  $I_{Residual}^l = 0$  and  $\mathcal{S} = \emptyset$ .
  2.  $\forall l \in \{1, \dots, L\}$ , Sort  $\left\{ H_i = \frac{\sigma_i^2}{|h_{i,m}|^2} \Omega_{i,m}^l, i \in \mathcal{N} \right\}$  in decreasing order with  $k$  being the sorted index. Find the  $P_i^{Max}$  as follows:
    - (a)  $H_{sum} = \sum_{i \in \mathcal{N}_l} H_i$ ,  $\gamma_l^{(Int)} = |\mathcal{N}| / (I_{th}^l + H_{sum})$ ,  $n = 1$ .
    - (b) **while**  $\gamma_l^{(Int)} > H_{k(n)}^{-1}$  **do**

$$H_{sum} = H_{sum} - H_{k(n)}, \mathcal{N} = \mathcal{N} \setminus \{k(n)\}, \gamma_l^{(Int)} = |\mathcal{N}| / (I_{th}^l + H_{sum}), n = n + 1$$
**end while**
    - (c) Set  $P_{i,m}^{(Int)}(l) = \left[ \frac{1}{\gamma_l^{(Int)} \Omega_{i,m}^l} - \frac{\sigma_i^2}{|h_{i,m}|^2} \right]^+$
  3. Evaluate  $P_{i,m}^{Max} = \min\{P_{i,m}^{(Int)}(1), P_{i,m}^{(Int)}(2), \dots, P_{i,m}^{(Int)}(L)\}$
  4. **if**  $\sum_{i \in \mathcal{N}_m} P_{i,m}^{Max} \leq \overline{P}_m; \forall m$   
 Let  $P_{i,m}^* = P_{i,m}^{Max}$  and stop the algorithm.  
**end if**
  5.  $\forall m$ , Perform the "cap-limited" waterfilling on the set of subcarriers  $\mathcal{N}_m$  under the per-user constraint  $\overline{P}_m$  and the maximum power that can be allocated to each subcarrier  $P_{i,m}^{Max}$  and find the set  $\mathcal{S}_m \subset \mathcal{N}_m$  where  $P_{i,m} i^{W.F} = P_{i,m}^{Max}$ .
  6. Let  $\mathcal{S} = \{S_1 \cup S_2 \dots \cup S_m\}$ , evaluate  $I_{Residual}^l = I_{th}^l - \sum_{i=1}^N P_{i,m}^{W.F} \Omega_{i,m}^l$ , set  $\mathcal{N} = \mathcal{S}$ ,  $I_{updated}^l = I_{Residual}^l + \sum_{i \in \mathcal{S}} P_{i,m}^{W.F} \Omega_{i,m}^l$  and apply again only the second and third steps to update  $P_{i,m}^{Max}$ .
  7.  $\forall m$ , Perform the "cap-limited" waterfilling on the set of subcarriers  $\mathcal{N}_m$  under the per-user constraint  $\overline{P}_m$  and the maximum power that can be allocated to each subcarrier  $P_{i,m}^{Max}$  and set  $P_{i,m}^* = P_{i,m}^{W.F}$ .
- 

In Fig. 4.4, the maximum power determination block applies (4.24) to find the maximum power that can be allocated to every subcarrier. Afterwards, the power constraints are tested and when one of them is violated, the per-user power budget is distributed between the subcar-

riers in the power budget distribution block. Afterwards, the residual interference is evaluated for each interference constraint and the power levels are re-adjusted by performing again the commands in the maximum power determination and power budgets distribution blocks.

## 4.5 Computational Complexity Analysis

The exhaustive enumeration scheme needs to iterate  $M^N$  times to exhaust all the cases, and its complexity of  $\mathcal{O}(N^3 M^N)$  is very hard to afford. The algorithm proposed in [22] has a complexity of  $\mathcal{O}(NM)$  with the assumption of sorted channel gains matrices. Therefore, including the sorting complexity of the different matrices as well as the iterative nature of the algorithm, the complexity will be more than  $\mathcal{O}(N \log N) + \mathcal{O}(NM)$ . Moreover, the algorithm proposed by Wang et al. in [24] has a complexity larger than  $\mathcal{O}(N^2 M)$  and lower than  $\mathcal{O}(N^3 M)$ . Note that the algorithms presented in [22, 24] are not considering fairness among users and are dealing with interference temperature constraint as several per-subcarrier maximum power constraints.

Recall that our proposed algorithm to solve problem  $P1$  is divided into two steps: the subcarriers to users allocation step and the power allocation step. Each subcarrier in the first step requires no more than  $M$  function evaluations to be assigned to one user depending on the size of the set  $\mathcal{U}$ . Hence, the computational complexity of the proposed subcarrier to user allocation algorithm is lower than or equal  $\mathcal{O}(NM)$ . In the power allocation algorithm, Step 2 in Algorithm 4.5 has a computational complexity of  $\mathcal{O}(N \log N)$  while Steps 5 and 7 of the algorithm execute the "cap-limited" waterfilling for every SU with a complexity of  $\sum_{m=1}^M \mathcal{O}(\mathcal{N}_m) \leq \mathcal{O}(N) \leq \mathcal{O}(N \log N)$  [41]. Step 6 has a complexity of  $\mathcal{O}(|\mathcal{S}| \log |\mathcal{S}|) \leq \mathcal{O}(N \log N)$ . Hence, the complexity of the power allocation algorithm is lower than  $\mathcal{O}(N \log N)$ . Thus, the overall asymptotic complexity of the proposed uplink resource allocation algorithm is lower than  $\mathcal{O}(N \log N) + \mathcal{O}(NM)$ . Table. 4.1 summarizes the complexity of the different algorithms.

**Table 4.1:** Computational complexity comparison

Algorithm	Complexity
<i>Optimal</i>	$\mathcal{O}(N^3M^N)$
<i>Wang [24]</i>	$\in [\mathcal{O}(N^2M), \mathcal{O}(N^3M)]$
<i>Fadel [22]</i>	$\mathcal{O}(N \log N) + \mathcal{O}(NM)$
<i>Proposed</i>	$\mathcal{O}(N \log N) + \mathcal{O}(NM)$
<i>Classical+Pr</i>	$\mathcal{O}(N \log N) + \mathcal{O}(NM)$

## 4.6 Simulation Results

The simulations are performed under the scenario given in Fig.4.1. The values of  $T_s$ ,  $\Delta f$ , and  $\sigma_i^2$  are assumed to be  $4\mu$  seconds, 0.3125 MHz and  $10^{-6}$  respectively. The OFDM system is assumed to have 6.67% of its symbol time as cyclic prefix (CP). For FBMC system, the prototype coefficients are assumed to be equal to PHYDYAS coefficients [42] [43] with overlapping factor  $K = 4$  as given by (2.16) and (2.17).

The channel gains  $h$  and  $g$  are outcomes of independent Rayleigh random variables with mean equal to 1. Perfect synchronization is assumed between SUs. All the results have been averaged over 1000 iterations. For the purpose of performance comparison, the following algorithms are considered:

1. **Optimal:** the subcarriers are allocated by exhaustive enumeration while the powers are allocated by solving  $P2$ . The optimal capacity is found without considering the minimum rate requirements.
2. **Classical+Pr:** the subcarriers are allocated according to the scheme used in non-cognitive OFDM systems [10], while the powers are allocated by solving  $P2$ . In [10], uniform powers are assumed on the subcarriers allocated to a given user. Based on this, the subcarriers are allocated sequentially to the user with the highest capacity.
3. **Fadel [22]:** the per SU maximum power constraint is generated by converting the interference constraint into per-subcarrier power constraints using (4.22). The algorithm allows initially the subcarrier sharing between the users to have a convex problem, and then approximated to have a binary channel allocation. Afterwards, the interference is

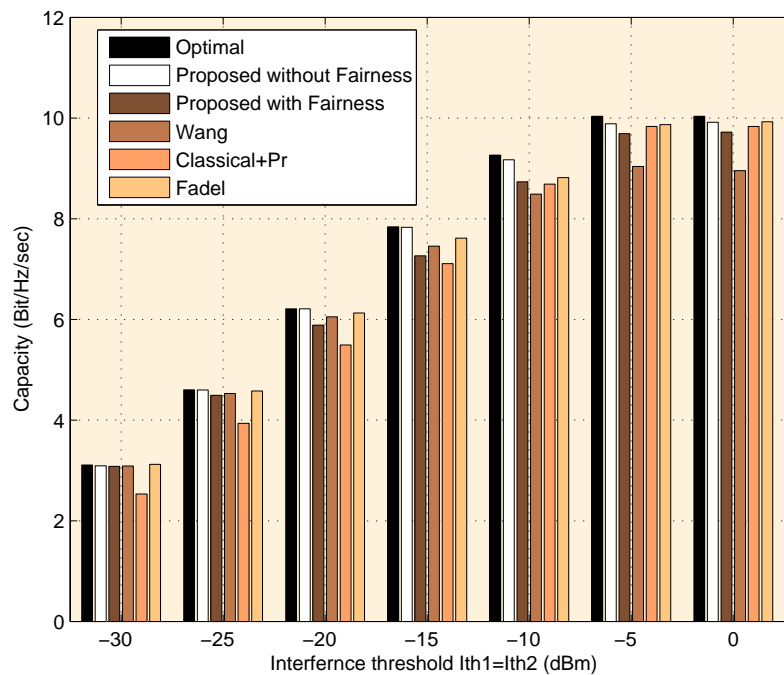
considered by limiting the allocated powers in order not to exceed the maximum allowed in-band interference.

4. **Wang** [24]: this algorithm allocated initially the subcarriers to the users with best channel. The initial allocation is adjusted based on change of the waterfilling levels when the subcarrier is assigned to another user. The interference constraint is converted into per-subcarrier power constraints using (4.22) to fit with algorithm formulation.

The simulation results are divided for three cases, the first two cases deal with an OFDM based CR system with low and high number of subcarriers and SUs, respectively. The third case compares the performance of the OFDM and FBMC systems.

#### 4.6.1 Case 1: OFDM with Small Number of SUs and Subcarriers

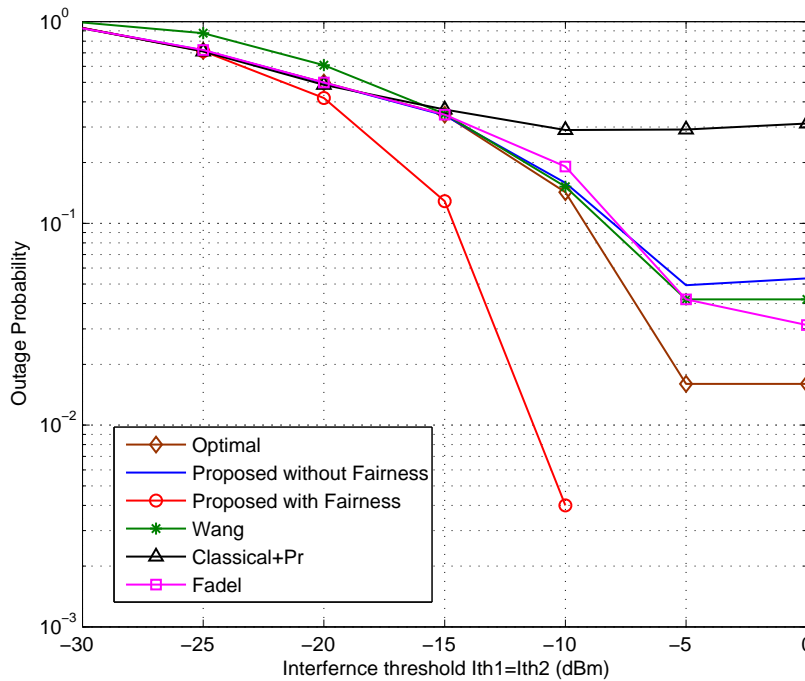
Two interference constraints belonging to two active PU bands , i.e.  $L = 2$ , are assumed with  $B^1 = B^2$  and  $I_{th}^1 = I_{th}^2$  (see Fig. 4.2). Fig. 4.5 plots the average capacity of a CR system with  $M = 3$  SUs versus the interference thresholds when the number of subcarriers



**Figure 4.5:** Three SUs Achieved capacity vs interference threshold when  $N = 8$  subcarriers,  $\overline{P}_m = 1$  mWatt,  $B^1 = B^2 = 1.25$  MHz, and  $R_{min} = 4$  Mbits/sec.



is  $N = 8$ , the per-user power budget  $\overline{P}_m = 1$  mWatt and  $B^1 = B^2 = 1.25$  MHz. The proposed algorithm without fairness achieves good performance in comparison with optimal and outperforms the other algorithms. When the minimum user's rate constraint of 4 Mbits/s is applied, i.e.  $R_{min} = 16$  bits per OFDM symbol, the proposed algorithm with fairness still performs well where the outage probability of having users below  $R_{min}$  is reduced as described in Fig. 4.6.

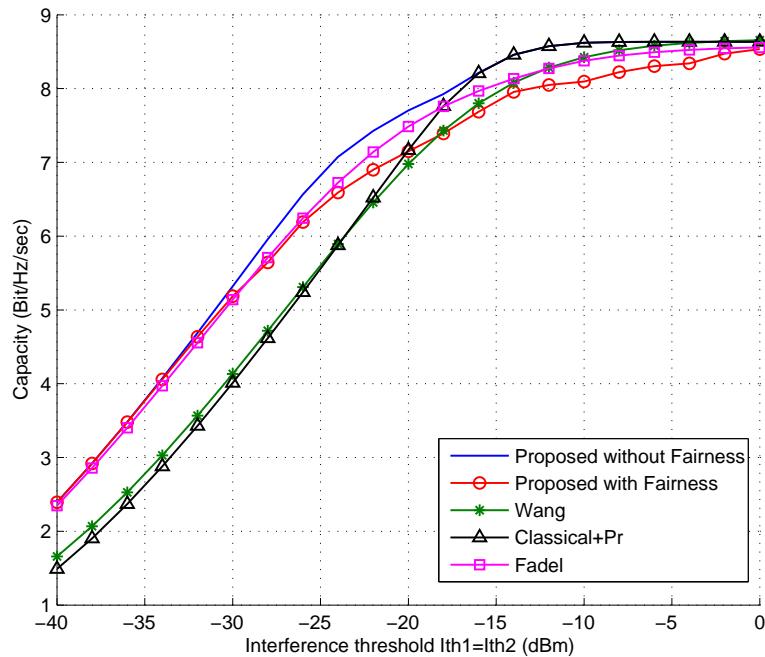


**Figure 4.6:** Outage probability vs allowed interference thresholds when  $N = 8$  subcarriers,  $\overline{P}_m = 1$  mWatt,  $B^1 = B^2 = 1.25$  MHz, and  $R_{min} = 4$  Mbits/sec.

#### 4.6.2 Case 2: OFDM with High Number of SUs and Subcarriers

In this case, the optimal solution is not simulated due to its extremely high computational complexity when the numbers of subcarriers and users are increased. The CR system is assumed to have  $M = 10$  SUs and  $N = 128$  subcarriers. The per-user power budget is set to be  $\overline{P}_m = 1$  mWatt. Two active PU bands are assumed with  $I_{th}^1 = I_{th}^2$  and  $B^1 = B^2 = 10$  MHz. The minimum rate for each user is set to be 20 Mbits/s, i.e.  $R_{min} = 80$  bits per OFDM symbol.

Fig. 4.7 plots the average capacity vs. the interference thresholds with  $I_{th}^1 = I_{th}^2$ . It can be observed that as the interference thresholds increase, the average sum rate increases since each



**Figure 4.7:** Achieved capacity vs allowed interference thresholds when  $N = 128$  subcarriers,  $M = 8$  SUs,  $\overline{P_m} = 1$  mWatt,  $B^1 = B^2 = 10$  MHz, and  $R_{min} = 20$  Mbits/sec.

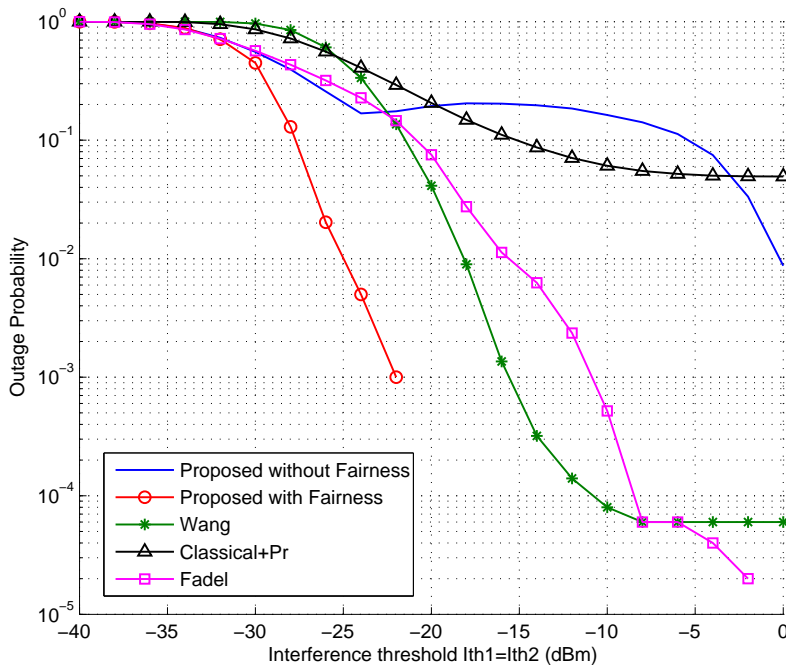
SU is allowed to have more flexibility in allocating more power on its subcarriers. Remark that the algorithms *Wang*, *Fadel* and *Classical+Pr* are not considering any fairness among users. The performance of the proposed algorithm without considering the fairness among the users outperforms the reference algorithms. Moreover, it is worth noting that the performance of the proposed algorithm without fairness is considered as an upper bound for the case when fairness is considered. From this fact, numerical results reveal that the proposed algorithm with fairness consideration achieves a very good performance. The behavior of the different algorithms in Fig. 4.7 can be separated into two main regions

1. When  $I_{th}^1 = I_{th}^2 \leq -20$  dBm: in this region, the proposed algorithm and *Fadel* algorithm significantly improves the achievable capacity of the CR system in comparison with the other algorithms. This is because the interference constraint value in this region highly affects the optimization problem. This reduces the achieved capacity by the *Classical+Pr* algorithm which does not take the interference constraint into consideration while allocating the subcarriers. This is also reveals the limited performance of *Wang* algorithm.

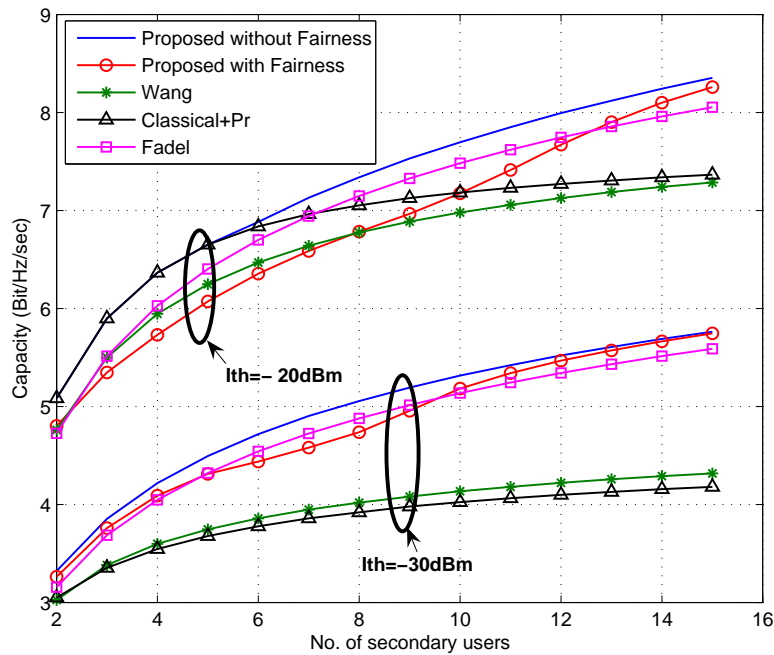
2. When  $I_{th}^1 = I_{th}^2 > -20$  dBm: in this region, the *Classical+Pr* algorithm has approximately the same performance of the proposed algorithm. This reflects that the system is behaving like a non-cognitive one due to the high interference constraint value. With sufficient power budgets, the proposed algorithm with fairness can perform as the one without fairness constraints with high interference threshold value.

Fig. 4.8 plots the outage probability of different algorithms. The outage probability of the proposed algorithm with fairness is much lower than that of the reference algorithms. Moreover, the outage probability decreases with the increase of the interference constraints because the different algorithms become more able to fulfill the minimum instantaneous rate for the different users. By using the proposed algorithm, the minimum rate is always achieved by all SUs when the interference constraint is more than  $-20$  dBm. This justified by the increase of the system ability to use more powers on the good CR channels even if they have high interference gain to the primary system.

Fig. 4.9 shows the average capacity versus the number of SUs when the interference thresholds are  $-20$ dBm and  $-30$ dBm. The capacity increases with the number of users due to



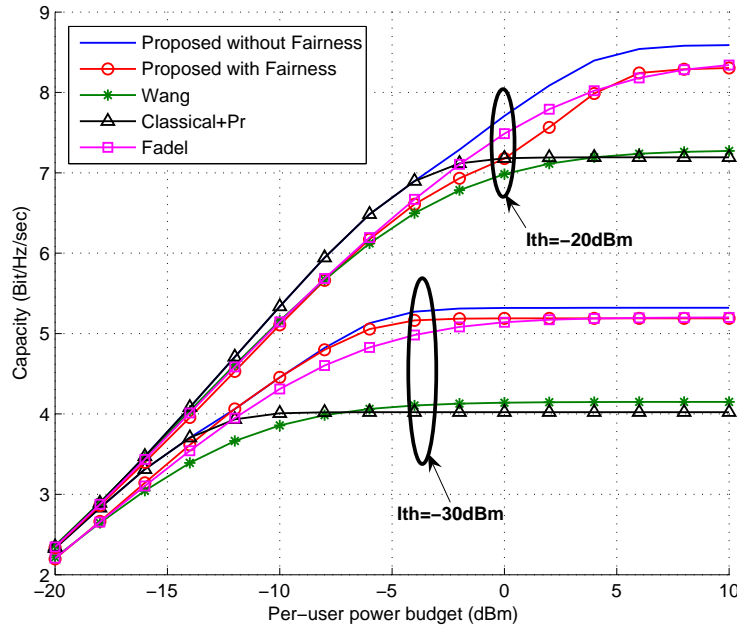
**Figure 4.8:** Outage probability vs allowed interference thresholds when  $N = 128$  subcarriers,  $M = 8$  SUs,  $\overline{P}_m = 1$  mWatt,  $B^1 = B^2 = 10$  MHz, and  $R_{min} = 20$  Mbits/sec.



**Figure 4.9:** Achieved capacity vs No. of SUs when  $N = 128$  subcarriers,  $\overline{P}_m = 1$  mWatt,  $B^1 = B^2 = 10$  MHz, and  $R_{min} = 20$  Mbits/sec.

the multiuser diversity. The lower the number of SUs, the smaller the difference between the proposed and *Classical+Pr* algorithms is. This is because the number of subcarriers that will be allocated to each user will increase which reduces the amount of power that will be allocated to each subcarrier and consequently the amount of interference imposed to the primary system. This causes the CR system to act as a non-cognitive system. The gap between the different algorithms decreases with the interference thresholds as the CR system becomes closer to the classical (non-cognitive) system.

Fig. 4.10 shows the average capacity versus per-user power constraint,  $\overline{P}_m$ , when the interference thresholds are  $-20$  dBm and  $-30$  dBm. The proposed algorithm outperforms the reference algorithms. The capacity of the CR system increases as the per-user power budget increases up to certain total power value. After this value, the capacity remains constant regardless of the increase of the per-user power because the system reaches to the maximum power that can be used with the given interference threshold. It is worth noticing that when the available SUs power is too low and unable to cause the pre-defined interference constraint, the CR system acts as a non-cognitive one where the proposed algorithm performs very close to the *Classical+Pr* algorithm. The gap between the curves with different interference constraints

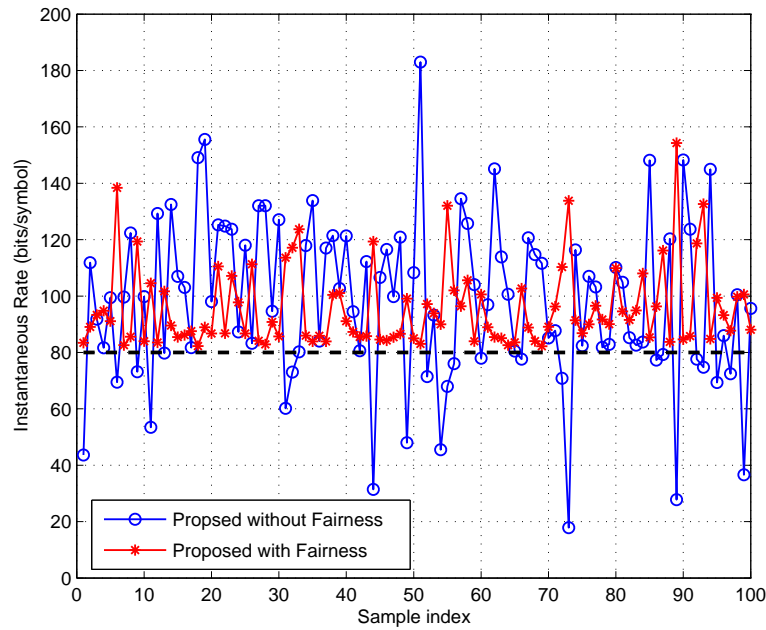


**Figure 4.10:** Achieved capacity vs per-user power  $\overline{P}_m$  when  $N = 128$  subcarriers,  $M = 8$  SUs,  $B^1 = B^2 = 10$  MHz, and  $R_{min} = 20$  Mbits/sec.

is increased with the increase of the power constraints, where the behavior of the algorithms performance can be described according to two main regions

1. When  $\overline{P}_m \leq -10$  dBm: in this region, the available power budgets is not able to introduce the maximum allowable interference to the primary system. Therefore, all the algorithms has close performance even with the increase of the interference constraint.
2. When  $\overline{P}_m > -10$  dBm: the CR system in this region becomes more able to introduce harmful interference to the primary system. Accordingly, as the interference constraint increased, the performance of the different algorithms is also increased where the efficiency of the proposed algorithm appears. Unlike to the previous region, the *Classical+Pr* algorithm and *Wang* algorithms has limited performance in comparison with the other algorithms.

Fig.4.11 plots an example of the instantaneous data rate for a given user over time for the proposed algorithm with and without fairness consideration when  $I_{th}^1 = I_{th}^2 = -20$  dBm. It can be noted that the proposed algorithm with fairness keeps the instantaneous rate above  $R_{min} = 80$  bits/symbol.

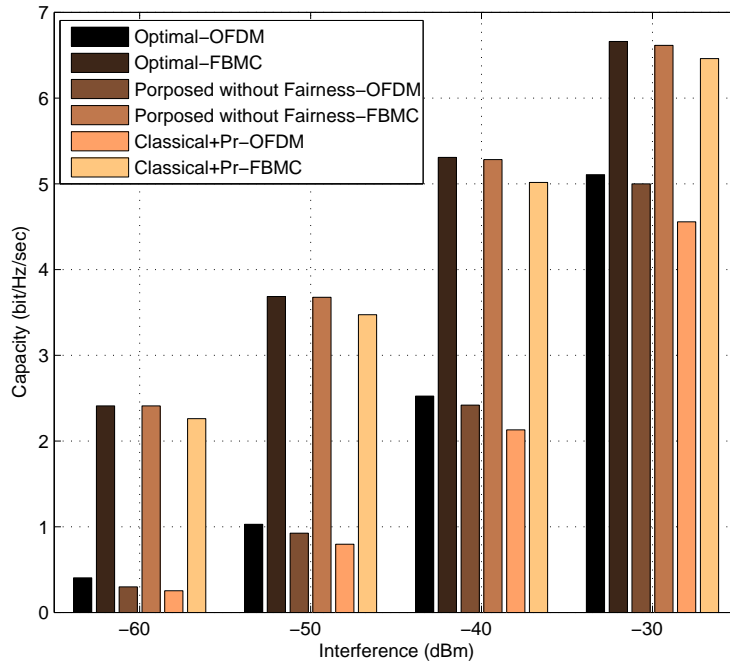


**Figure 4.11:** Instantaneous rates over time when  $N = 128$  subcarriers,  $M = 8$  SUs,  $\overline{P_m} = 1$  mWatt,  $B^1 = B^2 = 10$  MHz,  $I_{th}^1 = I_{th}^2 = -20$  dBm and  $R_{min} = 20$  Mbits/sec (80 bits per OFDM symbol).

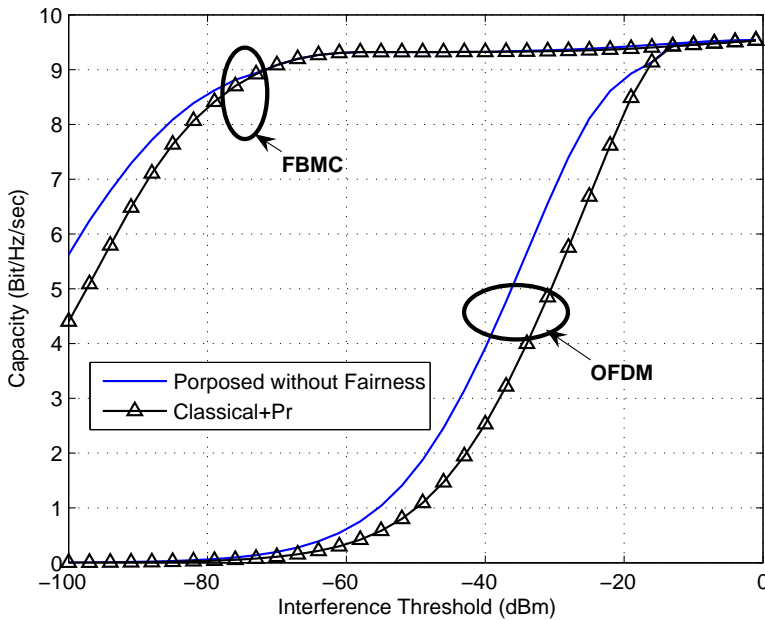
### 4.6.3 Case 3: OFDM and FBMC with Low/High Number of SUs and Subcarriers

Fig. 4.12 plots the average capacity of a CR system with  $M = 2$  SUs versus the interference threshold when the number of subcarriers is  $N = 8$ , the per-user power budget  $\overline{P_m} = 1$  mWatt. Single PU band with bandwidth  $B = 2.5$  MHz is assumed. The fairness constraint is omitted in this case. The proposed algorithm achieves a good performance in comparison with optimal and outperforms the *Classical+Pr* algorithm. Moreover, the capacity of FBMC based CR system is higher than that of OFDM based one since the sidelobes in FBMC's PSD are smaller than that in OFDM which introduces less interference to the PU's. Moreover, the CP insertion in OFDM based CR systems reduces the total capacity of the system.

Fig. 4.13 plots the average capacity versus the interference threshold when the number of subcarriers is  $N = 64$ , the number of SUs is  $M = 10$ , the per-user power budget is  $\overline{P_m} = 1$  mWatt and  $B = 10$  MHz. It can be observed that the gap between the different algorithms decreases with the interference threshold as the CR system becomes closer to the classical (non-cognitive) system. The capacity of FBMC based CR system is higher than that of OFDM.



**Figure 4.12:** Achieved capacity vs allowed interference threshold when  $N = 8$  subcarriers,  $M = 2$  SUs,  $\overline{P}_m = 1$  mWatt and  $B = 2.5$  MHz.



**Figure 4.13:** Achieved capacity vs allowed interference threshold when  $N = 64$  subcarriers,  $M = 10$  SUs,  $\overline{P}_m = 1$  mWatt and  $B = 10$  MHz.

In the case of OFDM system, the interference has a high effect on the system performance where the efficiency of the proposed algorithm appears. Moreover, the inefficiency of the *Classical+Pr* algorithm is shown when the interference constraint affects the optimization problem. In FBMC systems, the difference between the *Classical+Pr* algorithm and the proposed algorithm is very small because the FBMC system induces small amount of interference to the primary system which makes the CR system behaves very close to the non-cognitive one. In FBMC CR system with an extremely small interference threshold (or with high power budget), the proposed algorithm will be useful and achieves more capacity than the *Classical+Pr* algorithm as in the region below  $-70$  dBm in Fig. 4.13. Since the *Classical+Pr* algorithm and the proposed algorithm apply the same power allocation algorithm, it is clear that the capacity increase of the proposed algorithm over the *Classical+Pr* algorithm one results from the subcarrier allocation step.

## 4.7 Chapter Summary and Conclusions

In this chapter, we proposed an efficient resource allocation algorithm for uplink in multicarrier based CR networks with fairness consideration. The resource allocation problem is a mixed integer optimization problem in which achieving the optimal solution is hard to afford. To reduce the computational complexity, the allocation process is separated into two steps. In the first step, the subcarriers are allocated sequentially to the users according to their channel quality as well as the interference that they may introduce to the primary system. Afterwards, the multi-user system can be treated as a single user system where the per-user power budget is distributed in the second step among the subcarriers so that the total system capacity is maximized without causing excessive interference to the primary system. The fairness among users is considered within the subcarrier allocation by reducing the probability of having users whose instantaneous rates are below the given minimum rate. Without applying the fairness constraints, the proposed algorithm can achieve lower computational complexity along with better performance in comparison with the reference algorithms in which the fairness among users are not considered. The proposed algorithm achieves superior outage performance when the fairness among users is considered. We noticed that the gap among the different algorithms decreases with interference constraints as the CR system acts similar to non-cognitive system. This also happens when the available power budget is limited and able to introduce the max-



imum allowable interference. The proposed algorithm reduces the computational complexity from  $\mathcal{O}(N^3 M^N)$  required by the optimal solution to  $\mathcal{O}(N \log N) + \mathcal{O}(NM)$ . Moreover, simulation results prove that the FBMC based CR systems have more capacity than OFDM based ones which highlights the importance of considering the use of the FBMC in CR physical layer.

## 4.A Appendix

### 4.A.1 Derivation of the Optimal Power Allocation Given By Equations (4.15) and (4.23)

We want to find the optimal solution for the following optimization problem

$$\max_{P_{i,m}} \sum_{i=1}^N \log_2 \left( 1 + \frac{P_{i,m} |h_{i,m}|^2}{\sigma_i^2} \right) \quad (4.25)$$

$$s.t. \quad \sum_{i=1}^N P_{i,m} \Omega_{i,m}^l \leq I_{th}^l \quad \forall l \in \{1, \dots, L\} \quad (4.26)$$

$$\sum_{i \in \mathcal{N}_m} P_{i,m} \leq \overline{P}_m \quad \forall m \quad (4.27)$$

$$P_{i,m} \geq 0 \quad \forall i \quad (4.28)$$

The problem above is a convex optimization problem. Introducing the lagrange multipliers  $\alpha^l$ ,  $\mu_i$ , and  $\beta_m$  for the inequality constraints in (4.26), (4.27) and (4.28) respectively, the Lagrangian can be written as

$$G = - \sum_{i=1}^N R_i(P_{i,m}, h_{i,m}) + \sum_{l=1}^L \alpha^l \left( \sum_{i=1}^N P_{i,m} \Omega_{i,m}^l - I_{th}^l \right) + \sum_{m=1}^M \beta_m \left( \sum_{i \in \mathcal{N}_m} P_{i,m} - \overline{P}_m \right) - \sum_{i=1}^N P_{i,m} \mu_i \quad (4.29)$$

The Karush-Kuhn-Tucker (KKT) conditions can be written as follows

$$\begin{aligned} \alpha^l &\geq 0 \quad \forall l \in \{1, 2, \dots, L\}; & \beta_m &\geq 0 \quad \forall m \in \{1, 2, \dots, M\}; \\ \mu_i &\geq 0 \quad \forall i \in \{1, 2, \dots, N\}; & P_{i,m}^* &\geq 0; \\ \alpha^l &\left( \sum_{i=1}^N P_{i,m}^* \Omega_{i,m}^l - I_{th}^l \right) = 0 \\ \beta_m &\left( \sum_{i \in \mathcal{N}_m} P_{i,m}^* - \overline{P}_m \right) = 0; \quad \forall m \in \{1, 2, \dots, M\} \\ \mu_i P_{i,m}^* &= 0; \quad \forall i \in \{1, 2, \dots, N\} \\ \sum_{i=1}^N P_{i,m} \Omega_{i,m}^l - I_{th}^l &\leq 0 \\ \sum_{i \in \mathcal{N}_m} P_{i,m} - \overline{P}_m &\leq 0; \quad \forall m \in \{1, 2, \dots, M\} \\ \frac{\partial G}{\partial P_{i,m}^*} &= \frac{-1}{\frac{\sigma_i^2}{|h_{i,m}|^2} + P_{i,m}^*} + \sum_{l=1}^L \alpha^l \Omega_{i,m}^l + \beta_m - \mu_i = 0 \end{aligned} \quad (4.30)$$

Rearranging the last condition in (4.30) we get

$$P_{i,m}^* = \frac{1}{\sum_{l=1}^L \alpha^l \Omega_{i,m}^l + \beta_m - \mu_i} - \frac{\sigma_i^2}{|h_{i,m}|^2} \quad (4.31)$$

Since  $P_{i,m}^* \geq 0$ , we get

$$\frac{\sigma_i^2}{|h_{i,m}|^2} \leq \frac{1}{\sum_{l=1}^L \alpha^l \Omega_{i,m}^l + \beta_m - \mu_i} \quad (4.32)$$

If  $\frac{\sigma_i^2}{|h_{i,m}|^2} < \frac{1}{\sum_{l=1}^L \alpha^l \Omega_{i,m}^l + \beta_m}$ , then  $\mu_i = 0$  and hence

$$P_{i,m}^* = \frac{1}{\sum_{l=1}^L \alpha^l \Omega_{i,m}^l + \beta_m} - \frac{\sigma_i^2}{|h_{i,m}|^2} \quad (4.33)$$

Moreover, if  $\frac{\sigma_i^2}{|h_{i,m}|^2} > \frac{1}{\sum_{l=1}^L \alpha^l \Omega_{i,m}^l + \beta_m}$ , from (4.31) we get

$$\frac{1}{\sum_{l=1}^L \alpha^l \Omega_{i,m}^l + \beta_m - \mu_i} \geq \frac{\sigma_i^2}{|h_{i,m}|^2} > \frac{1}{\sum_{l=1}^L \alpha^l \Omega_{i,m}^l + \beta_m} \quad (4.34)$$

and since  $\mu_i P_{i,m}^* = 0$  and  $\mu_i \geq 0$ , we get that  $P_{i,m}^* = 0$ .

Therefore, the optimal solution can be written as follows

$$P_{i,m}^* = \left[ \frac{1}{\sum_{l=1}^L \alpha^l \Omega_{i,m}^l + \beta_m} - \frac{\sigma_i^2}{|h_{i,m}|^2} \right]^+ \quad (4.35)$$

where  $[x]^+ = \max(0, x)$ . If only one PU is assumed with interference constraint  $I_{th}^{l*}$ , (4.35) is reduced to

$$P_{i,m}^* = \left[ \frac{1}{\alpha^{l*} \Omega_{i,m}^{l*} + \beta_m} - \frac{\sigma_i^2}{|h_{i,m}|^2} \right]^+ \quad (4.36)$$

## Bibliography

- [1] T. Weiss and F. K. Jondral, "Spectrum pooling: An innovative strategy for the enhancement of spectrum efficiency," *IEEE Communications Magazine*, vol. 42, pp. S8 – S14, March 2004.
- [2] G. Bansal, M. J. Hossain, and V. K. Bhargava, "Optimal and suboptimal power allocation schemes for OFDM-based cognitive radio systems," *IEEE Transactions on Wireless Communications*, vol. 7, no. 11, pp. 4710–4718, November 2008.
- [3] S. Sadr, A. Anpalagan, and K. Raahemifar, "Radio resource allocation algorithms for the downlink of multiuser OFDM communication systems," *IEEE Communications Surveys and Tutorials*, vol. 11, no. 3, pp. 92 –106, quarter 2009.
- [4] J. Jang and K.B. Lee, "Transmit power adaptation for multiuser OFDM systems," *IEEE Journal on Selected Areas in Communications*, vol. 21, no. 2, pp. 171–178, Feb. 2003.
- [5] D. Kivanc, G. Li, and H. Liu, "Computationally efficient bandwidth allocation and power control for OFDMA," *IEEE Transactions on Wireless Communications*, vol. 2, no. 6, pp. 1150–1158, 2003.
- [6] Z. Shen, J. Andrews, and B. Evans, "Optimal power allocation in multiuser OFDM systems," in *IEEE Global Telecommunications Conference (GLOBECOM'03)*, 2003, vol. 1.
- [7] C. Wong, R. Cheng, K. Lataief, and R. Murch, "Multiuser OFDM with adaptive subcarrier, bit, and power allocation," *IEEE Journal on Selected Areas in Communications*, vol. 17, no. 10, pp. 1747–1758, 1999.
- [8] Wei Yu, Wonjong Rhee, S. Boyd, and J.M. Cioffi, "Iterative water-filling for gaussian vector multiple-access channels," *IEEE Transactions on Information Theory*, vol. 50, no. 1, pp. 145 – 152, Jan. 2004.
- [9] G. Munz, S. Pfletschinger, and J Speidel, "An efficient waterfilling algorithm for multiple access OFDM," in *IEEE Global Telecommunications Conference (GLOBECOM'02)*, Nov. 2002, vol. 1, pp. 681– 685.

- [10] Keunyoung Kim, Youngnam Han, and Seong-Lyun Kim, "Joint subcarrier and power allocation in uplink OFDMA systems," *IEEE Communications Letters*, vol. 9, no. 6, pp. 526–528, June 2005.
- [11] Long Gao and Shuguang Cui, "Efficient subcarrier, power, and rate allocation with fairness consideration for OFDMA uplink," *IEEE Transactions on Wireless Communications*, vol. 7, no. 5, pp. 1507–1511, May 2008.
- [12] L. Musavian and S. Aissa, "Capacity and power allocation for spectrum-sharing communications in fading channels," *IEEE Transactions on Wireless Communications*, vol. 8, no. 1, pp. 148–156, Jan. 2009.
- [13] X. Kang, Y-C. Liang, A. Nallanathan, H.K. Garg, and R. Zhang, "Optimal power allocation for fading channels in cognitive radio networks: Ergodic capacity and outage capacity," *IEEE Transactions on Wireless Communications*, vol. 8, no. 2, pp. 940–950, Feb. 2009.
- [14] R. Zhang, "On peak versus average interference power constraints for protecting primary users in cognitive radio networks," *IEEE Transactions on Wireless Communications*, vol. 8, no. 4, pp. 2112–2120, April 2009.
- [15] Rui Zhang and Y-C. Liang, "Exploiting multi-antennas for opportunistic spectrum sharing in cognitive radio networks," *IEEE Journal of Selected Topics in Signal Processing*, vol. 2, no. 1, pp. 88–102, Feb. 2008.
- [16] R. Zhang, S. Cui, and Y-C. Liang, "On ergodic sum capacity of fading cognitive multiple-access and broadcast channels," *IEEE Transactions on Information Theory*, vol. 55, no. 11, pp. 5161–5178, Nov. 2009.
- [17] P. Wang, M. Zhao, L. Xiao, Sh. Zhou, and J. Wang, "Power allocation in OFDM-Based cognitive radio systems," in *IEEE Global Telecommunications Conference (GLOBECOM'07)*, 2007, pp. 4061–4065.
- [18] G. Bansal, M. J. Hossain, and V. K. Bhargava, "Adaptive power loading for OFDM-Based cognitive radio systems," in *IEEE international conference on communication (ICC'07)*, 2007, pp. 5137–5142.

- [19] Yonghong Zhang and C. Leung, “Resource allocation in an OFDM-based cognitive radio system,” *IEEE Transactions on Communications*, vol. 57, no. 7, pp. 1928–1931, July 2009.
- [20] Z. Hasan, G. Bansal, E. Hossain, and V. Bhargava, “Energy-efficient power allocation in OFDM-based cognitive radio systems: A risk-return model,” *IEEE Transactions on Wireless Communications*, vol. 8, no. 12, pp. 6078–6088, December 2009.
- [21] M. Shaat and F. Bader, “Computationally efficient power allocation algorithm in multicarrier-based cognitive radio networks: OFDM and FBMC systems,” *EURASIP Journal on Advances in Signal Processing*, vol. 2010, Article ID 528378, 13 pages, 2010.
- [22] F.F. Digham, “Joint power and channel allocation for cognitive radios,” in *IEEE Wireless Communications and Networking Conference, WCNC’08*, April 2008, pp. 882–887.
- [23] A. Attar, M.R. Nakhai, and A.H. Aghvami, “Cognitive radio game for secondary spectrum access problem,” *IEEE Transactions on Wireless Communications*, vol. 8, no. 4, pp. 2121–2131, April 2009.
- [24] Wei Wang, Wenbo Wang, Qianxi Lu, and Tao Peng, “An uplink resource allocation scheme for OFDMA-based cognitive radio networks,” *International Journal of Communication Systems*, vol. 22, no. 5, pp. 603–623, 2009.
- [25] H. Zhang, D. Le Ruyet, D. Roviras, Y. Medjahdi, and H. Sun, “Spectral efficiency comparison of OFDM/FBMC for uplink cognitive radio networks,” *EURASIP Journal on Advances in Signal Processing*, vol. 2010, Article ID 621808, 14 pages, 2010.
- [26] Haewoon Nam, M.B. Ghorbel, and M. Alouini, “Location-based resource allocation for OFDMA cognitive radio systems,” in *Proceedings of the Fifth International Conference on Cognitive Radio Oriented Wireless Networks Communications (CROWNCOM)*, June 2010, pp. 1–5.
- [27] S.M. Almalfouh and G.L. Stuber, “Interference-aware radio resource allocation in OFDMA-Based cognitive radio networks,” *IEEE Transactions on Vehicular Technology*, vol. 60, no. 4, pp. 1699–1713, May 2011.

- [28] C.K. Tan, T.C. Chuah, and S.W. Tan, “Fair subcarrier and power allocation for multiuser orthogonal frequency-division multiple access cognitive radio networks using a Colonel Blotto game,” *IET Communications*, vol. 5, no. 11, pp. 1607–1618, 22 2011.
- [29] T. Adamo and A. Matros, “A Blotto game with incomplete information,” *Economics Letters*, vol. 105, no. 1, pp. 100–102, 2009.
- [30] T. Weiss and J. Hillenbrand, “Mutual interference in OFDM-based spectrum pooling systems,” in *Vehicular Technology Conference (VTC’04-Spring)*, May 2004, vol. 4.
- [31] B. Farhang-Boroujeny and R. Kempter, “Multicarrier communication techniques for spectrum sensing and communication in cognitive radios,” *IEEE Commun. Mag. (Special Issue on Cognitive Radios for Dynamic Spectrum Access)*, vol. 48, no. 4, pp. 80–85, Apr. 2008.
- [32] M. Shaat and F. Bader, “Efficient resource allocation algorithm for uplink in multicarrier-based cognitive radio networks with fairness consideration,” *Accepted in IET Communications*.
- [33] M. Shaat and F. Bader, “An uplink resource allocation algorithm for OFDM and FBMC based cognitive radio systems,” in *Proceedings of the Fifth International Conference on Cognitive Radio Oriented Wireless Networks Communications (CROWNCOM)*, June 2010, pp. 1–6.
- [34] M. Shaat and F. Bader, “Fair and efficient resource allocation algorithm for uplink multicarrier based cognitive networks,” in *IEEE 21st International Symposium on Personal Indoor and Mobile Radio Communications (PIMRC)*, Sept. 2010, pp. 1212–1217.
- [35] M. Shaat and F. Bader, “Efficient uplink subcarrier and power allocation algorithm in cognitive radio networks,” in *7th International Symposium on Wireless Communication Systems (ISWCS)*, Sept. 2010, pp. 223–227.
- [36] A. Skrzypczak, P. Siohan, and J.P. Javardin, “Power spectral density and cubic metric for the OFDM/OQAM modulation,” in *IEEE ISSPIT*, Vancouver-Canada, August 2006.

- [37] Rui Zhang, “Optimal power control over fading cognitive radio channel by exploiting primary user CSI,” in *IEEE Global Telecommunications Conference (IEEE GLOBECOM’08)*, Dec. 2008, pp. 1–5.
- [38] S. Boyd and L. Vandenberghe, *Convex optimization*, Cambridge Univ. Press, Cambridge, U.K., 2004.
- [39] A. Leke and J.M Cioffi, “A maximum rate loading algorithm for discrete multitone modulation systems,” in *IEEE Global Telecommunications Conference (GLOBECOM’97)*, 1997, vol. 3, pp. 1514–1518.
- [40] N. Papandreou and T. Antonakopoulos, “Bit and power allocation in constrained multicarrier systems: The single-user case,” *EURASIP Journal on Advances in Signal Processing*, vol. 2008, Article ID 643081, 4 pages, 2008.
- [41] Chengshi Zhao and Kyungsup Kwak, “Power/Bit loading in OFDM-Based cognitive networks with comprehensive interference considerations: The single-SU case,” *IEEE Transactions on Vehicular Technology*, vol. 59, no. 4, pp. 1910–1922, May 2010.
- [42] “PHYDYAS-Physical layer for dynamic spectrum access and cognitive radio,” Project website: [www.ict-phydyas.org](http://www.ict-phydyas.org).
- [43] M. Bellanger, “Filter banks and OFDM-OQAM for high throughput wireless LAN,” in *3rd International Symposium on Communications, Control and Signal Processing (IS-CCSP’08)*, March 2008, pp. 758–761.





# Resource Allocation in Multicarrier Based Relayed Cognitive Radio Systems

*"Real unselfishness consists in sharing the interests of others"* **George Santayana.**

## Contents

---

<b>5.1</b>	<b>Introduction</b>	<b>141</b>
<b>5.2</b>	<b>System Model</b>	<b>145</b>
<b>5.3</b>	<b>Problem Formulation</b>	<b>147</b>
<b>5.4</b>	<b>Asymptotically Optimal Solution Using Dual Decomposition Technique</b>	<b>150</b>
<b>5.5</b>	<b>Suboptimal Algorithm and Complexity Comparison</b>	<b>154</b>
<b>5.6</b>	<b>Simulation Results</b>	<b>157</b>
5.6.1	Case 1: Multi-relay CR System with Direct Link Transmission Ability	158
5.6.2	Case 2: Single-relay CR System with Blocked Direct Link Transmission	163
<b>5.7</b>	<b>Chapter Summary and Conclusions</b>	<b>166</b>
<b>5.A</b>	<b>Appendix</b>	<b>168</b>
5.A.1	Power Allocation Under the Interference Constraint Only with Known Subcarrier Pairs	168
	<b>Bibliography</b>	<b>171</b>

---

## 5.1 Introduction

Combining cognitive radio (CR) with cooperative communications can further improve the spectrum utilization and enhance the network performance. Different relays in the network can

collaborate in the spectrum sensing and assist the network transmissivity [1]. An overview of the cooperative communication in cognitive scenario has been presented in [2, 3].

The relay assisted transmission can be categorized into two basic strategies; amplify and forward (AF) and decode and forward (DF). In the AF strategy, the relay amplifies the received signal and then forwards it to the destination. On the other hand, in DF scheme, the relay decodes the received message before the retransmission. In multicarrier based relay networks, in addition to the power and subcarrier allocation required in non-cooperative networks, proper relay selection and subcarrier coupling in the different hops are required to improve the system performance.

The resource allocation problem in multicarrier based non-cognitive relay systems has been received much attention over the past years (see e.g. [4–14] and references therein). In [4], Wang et al. studied the optimal joint subcarrier matching and power allocation in a single relay system under the global power constraints. By making use of the equivalent channel power gains, a low complexity scheme is proposed. The algorithm matches the subcarriers according to order of their equivalent channel gains and applies the waterfilling among the matched pairs to find the optimal power allocation. The work in [4] is developed in [5] by the same authors to consider the individual power constraints in the source and relay where the matching is performed by pairing the subcarriers according to their channel qualities order. Afterwards, the waterfilling is performed separately at the nodes. The imbalance between the matched links capacities is removed by applying the waterfilling again to the side with the less capacity. In [6], Boostanimehr et al. developed a subcarrier selection, matching, and power allocation algorithm in single relay dual-hop networks. The algorithm formulates a linear assignment problem to select and match some subcarriers for relayed transmission and use the rest only for direct transmission. Based on the subcarrier matching and selection information, the power allocation is evaluated by solving the resulting convex optimization problem. Two different transmission protocols have been analyzed by Vandendrope et al. in [7] for a single relay dual-hop scenario with direct link. The difference between the two protocols is in the use of the non-relayed subcarriers not in the second time slot. The authors prove the efficiency of using these subcarrier to transmit new symbols from the source to the destination in the second time slot. In [9–12], the dual approach has been used to allocate the different system resources where Dang et al. in [9] dealt with multiple AF relays system while Hsu et al. considered DF single relay system in [10]. Additionally, Wang et al. in [11] optimize the transmission mode and allocate

the different resources considering multiple DF relays. The transmission at each subcarrier can be either in direct mode without any relay assisting, or can be relayed through one or several relays. Each one of the relays is eligible for assisting the transmission which exploits all the degree of freedom in the network and improve the system performance. The fairness between the nodes is considered in [12]. The transmission duration is optimized along with the other resources in [13] where the transmission durations at the source and the relay are designed to be asymmetric, which enhances the degree of freedom for transmission. The asymmetric time allocation has a significant impact on the system capacity when the system has a larger number of users (destinations) and a longer distance between the source and destinations. The resource allocation problem in multi-hop relay network is considered in [14]. The authors proved that under a fixed power allocation, the optimal subcarrier matching at each relay is achieved by matching the incoming and the outgoing channels according to their signal to noise ratios (SNR). Using this results, they showed that the joint power allocation and subcarrier matching can be decoupled into two independent steps where the subcarrier matching is performed first and followed by the power allocation. This separation principle is shown to hold for a variety of scenarios including AF and DF relaying strategies under either total or individual power constraints.

The CR should not disturb the operation of the primary system or negatively altering its performance and hence, the different resources should be distributed adequately so that the interference introduced to the primary system is not harmful. Mietzner et al. developed in [15] a fully decentralized and a distributed feedback-assisted power allocation schemes to maximize the output signal to interference plus noise ratio (SINR) or minimize the overall transmit power subject to predefined SINR target. Jia et al. proposed in [16] a centralized heuristic algorithm to select the most profitable pair of nodes and to allocate the different channels based on the availability of the spectrum. The interference to the primary system was not considered. In [17], a power allocation algorithm in a single relay DF orthogonal frequency division multiplexing (OFDM) based CR system has been proposed. Under the assumption of prior perfect subcarrier matching in the two hops, the authors treated the optimization problem in the source and the relay individually. The algorithm performance degrades significantly if the relay has to forward the receiving message on the same subcarrier, i.e. there is no subcarrier pairing. The work is developed in [18] to deal with the bit loading problem in relay. In [19], the CR network use the same spectrum of the primary network so that the transmission time and

power of relay-assisted CR network is optimized to reduce its generated interference while still guaranteeing its quality-of-service (QoS) level. Additionally, the authors of [20] proposed a distributed relay selection and power control algorithm. A stochastic optimization formulation is used where the tradeoff between the achievable rate and the network life time is considered. Liying et al. presented in [21] a joint relay selection and power allocation algorithm where the cognitive relay system is prevented from inducing severe interference to the primary system by limiting its maximum transmission power. In [22], the authors proposed an algorithm to select the best transmit way between the network nodes. The algorithm can select direct, dual or diversity transmission based on the available spectrum as well as the maximum allowable transmission powers. The systems in [21] and [22] are considering single carrier channels. To the best of our knowledge, the resource allocation with the consideration of the interference constraint in OFDM based multi-relay CR has not been investigated before.

Although that a considerable attention has been devoted to the use of OFDM systems, OFDM systems has several disadvantages like the sensitivity to the fast time variation of the radio channel in addition to the synchronization error problems. Furthermore, the cyclic prefix (CP) insertion in each OFDM symbol reduces the spectral efficiency. Additionally, in CR context, the large sidelobes of the OFDM signal causes high interference to the primary system. Filter bank multicarrier (FBMC) is an alternative multicarrier transmission scheme that can overcome the OFDM disadvantages by replacing the rectangular pulse used in OFDM by another prototype filter with better frequency localization [23, 24]. OFDM and FBMC are considered as a transmission techniques in this chapter.

This chapter considers the resource allocation problem in a dual-hop multi-relay DF multicarrier based CR system. The different system resources, i.e. powers, subcarriers and relays, are optimized jointly in order to maximize the system capacity. The resource allocation process is performed under the per-node power constraint as well as the interference to the primary system constraint. The chapter contributions are summarized as follows

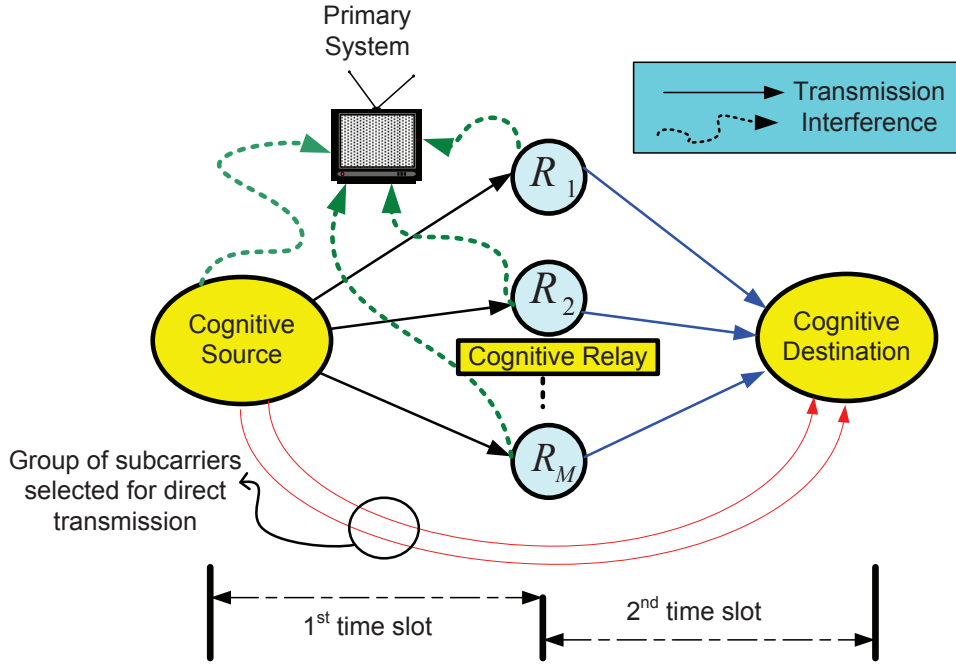
- We formulate the resource allocation problem as a mixed-integer programming problem. Thanks to the fulfillment of the time sharing condition, the dual decomposition technique is used to find jointly the optimal subcarrier pairs, selected relays and allocated powers. The group of subcarriers used for the direct transmission (without relaying) is determined as well.

- Due to the high computational complexity of the optimal algorithm, we proposed a heuristic suboptimal algorithm. The suboptimal algorithm allocates jointly the different resources taking into consideration the channel qualities, interference to the primary system, individual power budgets and the limitation introduced from applying the DF relaying strategy.
- We compare the performance of the OFDM and FBMC based CR systems. Moreover, the impact of the different constraints values on the system performance is investigated.

The contents of this chapter have been partially published in references [25–30]. This chapter is organized as follows: Section 5.2 gives the system model while the problem is formulated in Section 5.3. The asymptotically optimal solution is derived in Section 5.4. Next, the sub-optimal scheme is presented and the computational complexity is discussed in Section 5.5. Section 5.6 demonstrates selected numerical results. Finally, Section 5.7 concludes the chapter.

## 5.2 System Model

In this chapter, a multicarrier based relayed CR system is considered. Non-overlapping portions of the primary system bands are available to the CR system. The CR frequency spectrum accommodates  $N$  subcarriers each of them has  $\Delta f$  bandwidth. The CR system can use this frequency spectrum under the condition of not inducing severe interference to primary system, i.e. lower than the maximum interference the can be tolerated by the primary system  $I_{th}$ . As shown in Fig. 5.1, The CR system consists of source, destination and  $M$  relays. The source can transmit to the destination directly or through relays where each subcarrier can be used either for the relayed or direct transmission. The relayed transmission is used when it can improve the system performance. This enhancement occurs when the direct link is blocked due to the exitance of an obstacle or when the direct link has severe channel attenuation. The relays are assumed to operate in half-duplex mode with DF-protocol, thus receiving and transmitting in two different time slots. In the first time slot, the source transmits to the different relays over the subcarriers selected for the relayed transmission or to the destination over the subcarriers selected for the direct transmission. In the second time slot, the source remains silent in the second time slot, and the relays decode the received messages in the first time slot, re-encode it,



**Figure 5.1:** Cooperative relay cognitive radio network.

and then forward it to the destination. The  $j^{\text{th}}$  subcarrier in the source side which is selected for relayed transmission should be paired with only one subcarrier  $k$  in the destination side which may not be the same as  $j$  to form the  $(j, k)$  pair that should be assigned to only one relay  $m$ . The maximum total transmission powers that can be used in the source and the different relays are  $P_S$  and  $P_{R_m}$  respectively.

Let  $\Omega_i$  represents the interference factor experienced by the transmission of the CR over the  $i^{\text{th}}$  subcarrier and can be expressed by [31]

$$\Omega_i = \int_{d_i - B/2}^{d_i + B/2} |g_i|^2 \Phi_i(f) df \quad (5.1)$$

where  $\Phi_i$  is the power spectrum density (PSD) of the  $i^{\text{th}}$  subcarrier, and  $d_i$  is the spectral distance between the  $i^{\text{th}}$  subcarrier and the primary band.  $g_i$  denotes the channel gain between the  $i^{\text{th}}$  subcarrier and the primary band. Accordingly, the mutual interference power generated by the subcarrier  $i$  of the CR system to the primary band is

$$I_i = P_i \Omega_i \quad (5.2)$$

The expression of the PSD, i.e.  $\Phi_i$ , depends on the used multicarrier technique and can be

expressed as follows

$$\Phi_i = \begin{cases} T_s + 2 \sum_{r=1}^{T_s-1} (T_s - r) \cos(2\pi fr) & \text{OFDM} \\ |H_i(f)|^2 & \text{FBMC} \end{cases} \quad (5.3)$$

where  $|H_i(f)| = h[W/2] + 2 \sum_{r=1}^{W/2-1} h[(W/2) - r] \cos(2\pi fr)$ , where  $W$  is the length of each polyphase component and  $h[\cdot]$  are the filter coefficients defined by the PHYDYAS [32, 33] prototype filter defined by equations (2.16)-(2.17).  $T_s$  denotes the length of the OFDM symbol in number of samples.

By the same way, the interference power introduced by primary signal with PSD  $\psi(e^{j\omega})$  into the band of the  $i^{th}$  subcarrier is [31]

$$J_i = \int_{d_i - \Delta f/2}^{d_i + \Delta f/2} |y_i|^2 \psi(e^{j\omega}) d\omega \quad (5.4)$$

where  $y_i$  is the channel gain between the  $i^{th}$  subcarrier and the primary signal.

## 5.3 Problem Formulation

The relayed transmission rate of the  $j^{th}$  subcarrier in the source coupled with the  $k^{th}$  subcarrier in the destination and assigned to the  $m^{th}$  relay,  $R_{Relayed}(j, k, m)$ , can be evaluated as follows

$$R_{Relayed}(j, k, m) = \frac{1}{2} \min \left\{ \begin{array}{l} \log_2 \left( 1 + \frac{P_S^j \overline{H_{SR_m}^j}}{\sigma_{j,m}^2} \right) \\ \log_2 \left( 1 + \frac{P_{R_m D}^k \overline{H_{R_m D}^k}}{\sigma_{k,m}^2} \right) \end{array} \right. \quad (5.5)$$

where  $P_S^j$  is the power transmitted over the  $j^{th}$  subcarrier while in  $P_{R_m D}^k$  is the power transmitted over the  $k^{th}$  in the  $R_m$  to Destination link.  $R_m$  means the  $m^{th}$  relay. Moreover,  $\overline{H_{SR_m}^j} \overline{H_{R_m D}^k}$ <sup>1</sup> is the square of the  $j^{th}(k^{th})$  subcarrier fading gain over source to  $R_m$ ( $R_m$  to destination) link.  $\sigma_{j,m(k,m)}^2 = \sigma_{AWGN_{j,m(k,m)}}^2 + J_{j(k)}$ , where  $\sigma_{AWGN_{j,m(k,m)}}^2$  is the variance of the additive white Gaussian noise (AWGN) on the source to  $R_m$ ( $R_m$  to destination) link, and  $J_{j(k)}$  is the interference introduced by the PU signal into the  $j^{th}(k^{th})$  subcarrier which is evaluated using (5.4) and can be modeled as AWGN as described in [34]. If the source transmits to

<sup>1</sup>This notation is used in this chapter to indicate that the sentence is valid for the terms inside and outside the parentheses, i.e. the sentence can be read with the terms inside the parentheses and also the meaning is correct when it is read with the terms outside the parentheses.



the destination over the direct link, the transmission rate of the  $j^{th}$  subcarrier is given by

$$R_{Direct}(j) = \frac{1}{2} \log_2 \left( 1 + \frac{P_S \overline{H_{SD}^j}}{\sigma_{j,D}^2} \right) \quad (5.6)$$

where  $\overline{H_{SD}^j}$  is the square of the  $j^{th}$  subcarrier fading gain over source to destination link.  $\sigma_{j,D}^2$  is the variance of the noise in the direct link. The factor  $\frac{1}{2}$  in (5.5) and (5.6) accounts for the two time slots in each transmission frame.

To make the analysis more clear and without loss of generality, the following variables substitutions are considered:  $H_{SR_m}^j = \frac{\overline{H_{SR_m}^j}}{\sigma_{j,m}^2}$ ,  $H_{R_m D}^k = \frac{\overline{H_{R_m D}^k}}{\sigma_{k,m}^2}$ , and  $H_{SD}^j = \frac{\overline{H_{SD}^j}}{\sigma_{j,D}^2}$ .

Our objective is to maximize the CR system throughput by determining the subcarriers that will be used for the direct transmission and those which will be used for relayed transmission, and optimize the subcarrier pairing and relays assignment for the subcarriers used for relayed transmission. The available power budgets in the source and the different relays should be distributed among the subcarriers so that the instantaneous interference introduced to the primary system is below the maximum limit. Therefore, the optimization problem can be formulated as follows

$$\begin{aligned} & \max_{P_S^j \geq 0, P_{R_m D}^k \geq 0, \alpha_j, \pi_{j,k}^m, t_{j,k}} \mathcal{R} \\ & s.t. \\ & - \text{(C1: Source power constraint):} \quad \sum_{j=1}^N P_S^j \leq P_S \\ & - \text{(C2: Relays individual power constraints):} \quad \sum_{k=1}^N P_{R_m D}^k \leq P_{R_m}, \quad \forall m \\ & - \text{(C3: Interference at the first time slot):} \quad \sum_{j=1}^N P_S^j \Omega_j \leq I_{th} \\ & - \text{(C4: Interference at the second time slot):} \quad \sum_{m=1}^M \sum_{k=1}^N P_{R_m D}^k \Omega_{k,m} \leq I_{th} \\ & - \text{(C5: Relayed/Direct transmission constraint):} \quad \alpha_j \in \{0, 1\}, \quad \forall j \\ & - \text{(C6: Subcarrier pairing constraint):} \quad \sum_{k=1}^N t_{j,k} \leq 1, \quad \forall j; \\ & \quad \quad \quad \sum_{j=1}^N t_{j,k} \leq 1, \quad \forall k \\ & - \text{(C7: Relay Assignment constraint):} \quad \sum_{m=1}^M \pi_{j,k}^m = 1 \quad \forall j, k \end{aligned} \quad (5.7)$$

where

$$\mathcal{R} \triangleq \left[ \sum_{m=1}^M \sum_{j=1}^N \sum_{k=1}^N \frac{1}{2} \alpha_j \pi_{j,k}^m t_{j,k} R_{Relayed}(j, k, m) + \sum_{j=1}^N \frac{1}{2} (1 - \alpha_j) R_{Direct}(j) \right] \quad (5.8)$$

and  $N$  denotes the total number of subcarriers while  $I_{th}$  is the interference threshold prescribed by PU.  $P_S$  and  $P_{R_m}$  are the available power budgets in the source and the  $m^{th}$  relay respectively.  $\Omega_j$  and  $\Omega_{k,m}$  are the  $j^{th}$  ( $k^{th}$ ) subcarrier interference factor to the PU band from the source and the  $m^{th}$  relay respectively.  $\alpha_j \in \{0, 1\}$  is the subcarrier transmission mode indicator which has a value of one when the subcarrier is used for relayed transmission while equals zero if the subcarrier is used for the direct transmission. The subcarrier pairing constraint ensures that each relayed transmission subcarrier in the source is paired with only one subcarrier in the destination where  $t_{j,k} \in \{0, 1\}$  is the subcarrier pairing indicator, i.e.  $t_{j,k} = 1$  if the  $j^{th}$  subcarrier in the source is paired with the  $k^{th}$  in the destination, and zero otherwise. Additionally,  $\pi_{j,k}^m$  is the relay assignment indicator which equals to one when the pair  $(j, k)$  is assigned to the  $m^{th}$  relay and zero otherwise. The source performs the resource allocation where all the instantaneous fading gains are assumed to be perfectly known. The assumption of perfect knowledge of all the channels is a typical assumption for researchers in this area [34–36] and it is assumed in this chapter too. The result of the ideal case can serve as an upper-bound for the work include another assumption or relaxation. Remark that the channel gains between the CR system nodes can be obtained practically by the classical channel estimation techniques, while the channel gains between the CR system and the PU can be obtained by estimating the received signal power from the primary terminal when it transmits; under the assumptions of pre-knowledge on the primary transmit power levels and the channel reciprocity [37].

Assume that the subcarrier  $j$  is used for the relayed transmission, i.e.  $\alpha_j = 1$ , and paired with the  $k^{th}$  subcarrier in the destination side. From (5.5), the maximum capacity over the  $(j, k)$  subcarrier pair which is allocated to the  $m^{th}$  relay can be achieved when  $P_S^j H_{SR_m}^j = P_{R_m D}^k H_{R_m D}^k$ . Therefore, the power allocated at  $R_m$  can be expressed as function of the power at the source as  $P_{R_m D}^k = \frac{P_S^j H_{SR_m}^j}{H_{R_m D}^k}$ . Hence, the optimization problem in (5.7) can be re-written as follows

$$\begin{aligned}
 & \max_{P_S^j \geq 0, \alpha_j, \pi_{j,k}^m, t_{j,k}} \widehat{\mathcal{R}} \\
 & s.t. \quad (C1), (C3), (C5), (C6), (C7) \\
 & - \widehat{C2}: \quad \sum_{j=1}^N \sum_{k=1}^N \alpha_j \pi_{j,k}^m t_{j,k} \frac{P_S^j H_{SR}^j}{H_{RD}^k} \leq P_{R_m}; \quad \forall m \\
 & - \widehat{C4}: \quad \sum_{m=1}^M \sum_{j=1}^N \sum_{k=1}^N \alpha_j \pi_{j,k}^m t_{j,k} \frac{P_S^j H_{SR}^j}{H_{RD}^k} \Omega_{k,m} \leq I_{th}
 \end{aligned} \tag{5.9}$$

where

$$\widehat{\mathcal{R}} \triangleq \left[ \sum_{m=1}^M \sum_{j=1}^N \sum_{k=1}^N \frac{1}{2} \alpha_j \pi_{j,k}^m t_{j,k} \log_2 (1 + P_S^j H_{SR_m}^j) + \sum_{j=1}^N \frac{1}{2} (1 - \alpha_j) \log_2 (1 + P_S^j H_{SD}^j) \right] \quad (5.10)$$

## 5.4 Asymptotically Optimal Solution Using Dual Decomposition Technique

Finding the optimization variables  $P_S^j$ ,  $\alpha_j$ ,  $t_{j,k}$  and  $\pi_{j,k}^m$  in (5.9) is a mixed-integer programming problem where the complexity is prohibitive for large number of subcarriers. The problem in (5.9) is satisfying the time sharing condition described in [38] and hence, the duality gap of the problem is negligible as the number of subcarrier is sufficiently large, i.e.  $N > 8$ , regardless of the convexity of the problem. (refer to Section 2.4.4 for more details about the time sharing condition). The solution obtained by the dual method is asymptotically optimal [38].

The dual problem associated with the primal problem (5.9) can be written as

$$\min_{\beta \geq 0; \gamma_m \geq 0; \lambda \geq 0; \mu \geq 0} g(\beta, \gamma_m, \lambda, \mu) \quad (5.11)$$

where  $\beta$  and  $\gamma_m$  are the dual variables associated with the power constraints at the source and at the different relays respectively. Moreover, the dual variables  $\lambda$  and  $\mu$  are related to the interference constraints at the first and second time slots respectively. The dual function  $g(\beta, \gamma_m, \lambda, \mu)$  is defined as follows

$$g(\beta, \gamma_m, \lambda, \mu) \triangleq \max_{P_S^j > 0, \alpha_j, t_{j,k}, \pi_{j,k}^m} \mathcal{L} \quad (5.12)$$

s.t. (C5), (C6), (C7)

where the Lagrangian  $\mathcal{L}$  is given by

$$\begin{aligned} \mathcal{L} = & \sum_{m=1}^M \sum_{j=1}^N \sum_{k=1}^N \frac{1}{2} \alpha_j \pi_{j,k}^m t_{j,k} \log_2 (1 + P_S^j H_{SR_m}^j) + \sum_{j=1}^N (1 - \alpha_j) \log_2 (1 + P_S^j H_{SD}^j) + \\ & \beta \left( P_S - \sum_{m=1}^M \sum_{j=1}^N P_S^j \right) + \sum_{m=1}^M \gamma_m \left( P_{R_m} - \sum_{j=1}^N \sum_{k=1}^N \alpha_j \pi_{j,k}^m t_{j,k} \frac{P_S^j H_{SR_m}^j}{H_{R_m D}^k} \right) + \\ & \lambda \left( I_{th} - \sum_{m=1}^M \sum_{j=1}^N P_S^j \Omega_j \right) + \mu \left( I_{th} - \sum_{m=1}^M \sum_{j=1}^N \sum_{k=1}^N \alpha_j \pi_{j,k}^m t_{j,k} \frac{P_S^j H_{SR_m}^j}{H_{R_m D}^k} \Omega_{k,m} \right) \end{aligned} \quad (5.13)$$

The dual function in (5.12) can be rewritten as follows

$$g(\beta, \gamma_m, \lambda, \mu) = \max_{P_S^j > 0, \alpha_j, t_{j,k}, \pi_{j,k}^m} \left[ \sum_{m=1}^M \sum_{j=1}^N \sum_{k=1}^N \alpha_j \pi_{j,k}^m t_{j,k} \mathcal{D}_{relay}(P_S^j, k, m) + \sum_{j=1}^N (1 - \alpha_j) \mathcal{D}_{direct}(j) + \beta P_S + \sum_{m=1}^M \gamma_m P_{R_m} + I_{th}(\lambda + \mu) \right] \quad (5.14)$$

*s.t.* (C5), (C6), (C7)

where

$$\mathcal{D}_{relay}(P_S^j, k, m) = \frac{1}{2} \log_2(1 + P_S^j H_{SR_m}^j) - \beta P_S^j - \lambda P_S^j \Omega_j - \gamma_m \frac{P_S^j H_{SR_m}^j}{H_{R_mD}^k} - \mu \frac{P_S^j H_{SR_m}^j}{H_{R_mD}^k} \Omega_{k,m} \quad (5.15)$$

and

$$\mathcal{D}_{direct}(j) = \frac{1}{2} \log_2(1 + P_S^j H_{SD}^j) - \beta P_S^j - \lambda P_S^j \Omega_j \quad (5.16)$$

Therefore, to get the solution, we can start by assuming any initial values for the different dual variables and also assuming that the value of the variable  $\alpha_j$  is known. Hence, (5.14) is decomposed into  $N(NM + 1)$  independent power allocation sub-problems. Depending on the value of the variable  $\alpha_j$ , we have the following two cases:

- **Case 1: when the  $j^{th}$  subcarrier is used for relayed transmission, i.e.  $\alpha_j = 1$**

Assume  $(j, k)$  to be a valid subcarrier pair and is already matched and allocated to the  $m^{th}$  relay. Hence, the optimal power allocation can be determined by solving the following sub-problem for every  $(j, k, m)$  assignment

$$\max_{P_S^j} \mathcal{D}_{relay}(P_S^j, k, m) \quad s.t. \quad P_S^j \geq 0 \quad (5.17)$$

Equating  $\frac{\partial \mathcal{D}_{relay}(P_S^j, k, m)}{\partial P_S^j} = 0$ , the optimal power in (5.17) is expressed as follows

$$P_S^{*j} = \left[ \frac{1}{\beta + \gamma_m \frac{H_{SR_m}^j}{H_{R_mD}^k} + \lambda \Omega_j + \mu \frac{H_{SR_m}^j}{H_{R_mD}^k} \Omega_{k,m}} - \frac{1}{H_{SR_m}^j} \right]^+ \quad (5.18)$$

where  $[x]^+ = \max(0, x)$ . As the value of the variable  $\alpha_j$  is assumed to be one in this case, the optimal power allocation found by (5.18) can be substituted in the first part of (5.14) to eliminate the power variable and hence the following problem should be solved

for every  $(j, k)$  pair

$$g(\beta, \gamma_m, \lambda, \mu) = \max_{\pi_{j,k}^m} \left[ \sum_{m=1}^M \sum_{j=1}^N \sum_{k=1}^N \pi_{j,k}^m t_{j,k} \mathcal{D}_{relay}(P_S^{*j}, k, m) + \beta P_S + \sum_{m=1}^M \gamma_m P_{R_m} + I_{th}(\lambda + \mu) \right] \quad (5.19)$$

*s.t.* (C7)

Therefore, the optimal relay assignment strategy is achieved by allocating the  $(j, k)$  pair to the relay which maximizes the function  $\mathcal{D}_{relay}(P_S^{*j}, k, m)$ , i.e.  $\pi_{j,k}^{m^*} = 1$  if  $m = \arg \max_m \mathcal{D}_{relay}(P_S^{*j}, k, m)$  and zero otherwise. By performing this allocation, the best relay is determined for every possible subcarrier pair .

- **Case 2: when the  $j^{th}$  subcarrier is used for direct transmission, i.e.  $\alpha_j = 0$**

The following sub-problem should be solved for every subcarrier  $j$

$$\max_{P_S^j} \mathcal{D}_{direct}(j) \quad s.t. \quad P_S^j \geq 0 \quad (5.20)$$

Solving (5.20) for the optimal power we can find

$$P_S^{*j} = \left[ \frac{1}{\beta + \lambda \Omega_j} - \frac{1}{H_{SD}^j} \right]^+ \quad (5.21)$$

Using the previous analysis, and for given dual variables values, we can find the optimal power levels and relay assignment of the pair  $(j, k)$  when the subcarrier is used for relayed transmission, and we can evaluate the optimal power allocation when it is used for direct transmission. The last remaining step is to determine the optimal subcarrier pairs and to decide whether the  $j^{th}$  subcarrier should be used for direct transmission or for relayed one. Therefore, the following problem should be solved

$$g(\beta, \gamma_m, \lambda, \mu) = \max_{\alpha_j, t_{j,k}} \left[ \sum_{j=1}^N \sum_{k=1}^N \alpha_j t_{j,k} \mathcal{D}_{relay}(P_S^{*j}, k, m^*) + \sum_{j=1}^N (1 - \alpha_j) \mathcal{D}_{direct}(j) + \beta P_S + \sum_{m=1}^M \gamma_m P_{R_m} + I_{th}(\lambda + \mu) \right] \quad (5.22)$$

*s.t.* (C5), (C6)

where  $m^*$  in  $\mathcal{D}_{relay}(P_S^{*j}, k, m^*)$  denotes the best relay selected for the  $(j, k)$  pair as described previously. For a possible  $(j, k, m^*)$  assignment, i.e.  $t_{j,k} = 1$  and  $\pi_{j,k}^{m^*} = 1$ , (5.22) is reduced to

$$\max_{\alpha_j} \alpha_j \mathcal{D}_{relay}(P_S^j, k, m^*) + (1 - \alpha_j) \mathcal{D}_{direct}(j) \quad (5.23)$$

where  $P_S^{*j}$  in  $\mathcal{D}_{relay}$  is given by (5.17) while  $P_S^{*j}$  in  $\mathcal{D}_{direct}$  is given by (5.20). By solving problem (5.23), we found

$$\alpha_j = \begin{cases} 1 & \text{if } \mathcal{D}_{relay}(P_S^{*j}, k, m^*) \geq \mathcal{D}_{direct}(j) \\ 0 & \text{otherwise} \end{cases} \quad (5.24)$$

Accordingly, the maximum value between  $\mathcal{D}_{direct}(j)$  and  $\mathcal{D}_{relay}(P_S^{*j}, k, m^*)$  decides whether the subcarrier  $j$  should be used for direct transmission or for relayed transmission based on to the assignment  $(j, k, m^*)$ . Therefore, (5.22) can be rewritten as follows

$$g(\beta, \gamma_m, \lambda, \mu) \triangleq \max_{t_{j,k}} \left[ \sum_{j=1}^N \sum_{k=1}^N t_{j,k} \mathcal{D}_{max}(P_S^{*j}, k, m^*) + \beta P_S + \sum_{m=1}^M \gamma_m P_{R_m} + I_{th}(\lambda + \mu) \right] \quad (5.25)$$

s.t. (C6)

where  $\mathcal{D}_{max}(P_S^{*j}, k, m^*) = \max\{\mathcal{D}_{relay}(P_S^{*j}, k, m^*), \mathcal{D}_{direct}(j)\}$ . The problem in (5.25) is a linear assignment problem that can be solved efficiently by the Hungarian method with a complexity of  $O(N^3)$  [39]. Note that the set of subcarriers used for direct transmission can be determined from the optimal solution  $t_{j,k}^*$  when the profit value associated with the optimal pair  $(j, k)$  with  $t_{j,k}^* = 1$  is  $\mathcal{D}_{max}(P_S^{*j}, k, m^*) = \mathcal{D}_{direct}(j)$ .

The subgradient method can be used to solve the dual problem with guaranteed convergence. After finding the optimal solution, i.e.  $P_S^{*j}$ ,  $\pi_{j,k}^{m^*}$ ,  $t_{j,k}^*$  and  $\alpha_j$  of the dual function at a given dual points  $\beta$ ,  $\gamma_m$ ,  $\lambda$  and  $\mu$ , the dual variables at the  $(i+1)^{th}$  iteration are updated as

$$\begin{aligned} \beta^{(i+1)} &= \beta^{(i)} - \delta^{(i)} \left( P_S - \sum_{j=1}^N P_S^{*j} \right) \\ \gamma_m^{(i+1)} &= \gamma_m^{(i)} - \delta^{(i)} \left( P_{R_m} - \sum_{k=1}^N \sum_{j=1}^N \alpha_j^* t_{j,k}^* \frac{P_S^{*j} H_{SR_m}^j}{H_{R_m D}^k} \right); \forall m \\ \lambda^{(i+1)} &= \lambda^{(i)} - \delta^{(i)} \left( I_{th} - \sum_{j=1}^N P_S^{*j} \Omega_j \right) \\ \mu^{(i+1)} &= \mu^{(i)} - \delta^{(i)} \left( I_{th} - \sum_{m=1}^M \sum_{k=1}^N \sum_{j=1}^N \alpha_j^* \pi_{j,k}^{m^*} t_{j,k}^* \frac{P_S^{*j} H_{SR_m}^j}{H_{R_m D}^k} \Omega_{k,m} \right) \end{aligned} \quad (5.26)$$

where  $\delta^{(i)}$  is the step size that can be updated according to the nonsummable diminishing step size policy [40].

## 5.5 Suboptimal Algorithm and Complexity Comparison

In order to solve the problem efficiently, we propose in this section a suboptimal greedy algorithm by which the different system resources are allocated jointly with lower computational complexity than that of the optimal solution.

We commence the description of the suboptimal algorithm by defining the sets  $\mathcal{A}$  and  $\mathcal{B}$  to include all the non-assigned subcarriers in the source and the destination sides respectively. Moreover, define the set  $\mathcal{M}$  to contain all the relays in the network. In the source side, assume that the available source power is distributed uniformly over the subcarriers, i.e.  $P_j^{uni} = \frac{P_S}{N}$ , and also assume that the interference introduced to the primary system by every subcarrier is equal and hence from (5.2), the maximum allowable power that can be allocated to the  $j^{th}$  subcarrier is  $P_j^{max} = \frac{I_{th}}{N\Omega_j}$ . Therefore, the allocated power to the  $j^{th}$  subcarrier in the source side is  $P_S^j = \min(P_j^{uni}, P_j^{max})$ . The assigning procedures of a particular subcarrier  $j \in \mathcal{A}$  are detailed in Algorithm 5.6.

---

### Algorithm 5.6 Sub-optimal Algorithm

---

1. For every relay  $m \in \mathcal{M}$ , evaluate the rate  $R_{j,m}^{Source} = \frac{1}{2} \log_2 (1 + P_S^j H_{SR_m}^j)$  achieved by allocating the subcarrier  $j$  to the  $m^{th}$  relay.
  2. For every relay  $m \in \mathcal{M}$  and subcarrier  $k \in \mathcal{B}$ , compute the required power to achieve a rate in the relay to destination link equal to that in the source to relay link, i.e.  $P_{j,k,m}^{rate} = \frac{(2^{(2R_{j,m}^{Source})} - 1)}{H_{R_m D}^k}$ . Then, evaluate  $P_{k,m}^{uni} = \frac{P_{R_m}}{|\mathcal{B}|}$  and  $P_{k,m}^{max} = \frac{I_{th}}{N\Omega_{k,m}}$  where  $|\mathcal{B}|$  means the cardinality of the set  $\mathcal{B}$ . Afterwards, set  $Power_{j,k,m} = \min(P_{j,k,m}^{rate}, P_{k,m}^{uni}, P_{k,m}^{max})$ .
  3. Find  $k^*$  and  $m^*$  satisfying  $(k^*, m^*) = \arg \max_{k,m} (Power_{j,k,m} H_{R_m D}^k)$ . If  $P_S^j H_{SD}^j > Power_{j,k^*,m^*} H_{R_{m^*} D}^{k^*}$ , the direct link is selected. Otherwise, set  $t_{j,k^*} = 1$ ,  $\pi_{(j,k^*)}^{m^*}$  and  $P_{R_{m^*} D}^k = Power_{j,k^*,m^*}$  and update the  $m^{*th}$  relay power budget as  $P_{R_{m^*}} = P_{R_{m^*}}^* - Power_{j,k^*,m^*}$ .
  4. Remove the subcarriers  $j$  and  $k^*$  (in case of relayed transmission) from the sets  $\mathcal{A}$  and  $\mathcal{B}$  respectively and repeat the procedures until the set  $\mathcal{A}$  is empty.
- 

The first step in the proposed algorithm determines the achieved capacity by allocating a

given subcarrier  $j$  in the source side to a specific relay. From (5.5), the rate achieved on the relay to destination link should be equal to that in the source to relay link in order to avoid the capacity imbalance. Therefore, the amount of power required to achieve this equality is evaluated in the second step. The limitation of the power and interference constraints are considered by the third step where the relayed or direct transmission is determined. The subcarrier pairing and relay selection indicators as well as the remaining relays power are updated in the last step.

In the optimal solution derived in the previous section,  $(M + 3)$  dual variables are updated in every iteration. Using these values,  $N(NM + 1)$  function evaluations are performed to find the power allocation. Afterwards,  $M$  function evaluations are performed for every possible subcarrier pair where there are  $N!$  subcarrier matching possibilities. By including the computational complexity of the Hungarian method and the  $N$  functions evaluations required to classify the subcarrier into the direct or relayed transmission, the optimal solution derived in the previous section has a complexity of  $\mathcal{O}(T(MN^2 + M(N!) + 2N + N^3))$  where  $T$  is the number of iterations required to converge which is usually high [38]. In the proposed scheme, every subcarrier in the source side requires no more than  $(M + MN)$  function evaluations to be paired and assigned to the relay or selected for the direct transmission. Therefore, the complexity of the proposed algorithm is  $\mathcal{O}(MN + MN^2)$ . Table. 5.1 summarizes the complexity of the algorithms.

If the direct link between the source and the destination is blocked in all the subcarriers due to large distance or existence of an obstacle, the dual decomposition technique is adopted after assuming that all the subcarrier are used for relayed transmission, i.e.  $\alpha_j = 1, \forall j$ . Moreover, the third step in Algorithm 5.6 should be modified accordingly by removing the part related to direct transmission selection. Additionally, if the CR system has only one relay, i.e.  $M = 1$ , the relay selection step in the optimal solution should be omitted. The Algorithm 5.6 is still valid and can be used to find jointly the subcarrier pairs and the allocated powers. However, in case of single relay CR system, the scheme used in non-cognitive system can be adapted.

**Table 5.1:** Computational complexity comparison

Algorithm	Complexity
<i>Asymptotically Optimal</i>	$\mathcal{O}(T(MN^2 + M(N!) + 2N + N^3))$
<i>Proposed suboptimal</i>	$\mathcal{O}(MN + MN^2)$



Specifically, the optimal subcarrier pairing strategy in non-cognitive DF networks is achieved by ordering the subcarriers in the source and the destination sides according to their signal to noise ratio (SNR), and pair the subcarriers with the same order together [5]. Conversely, this strategy is not optimal in CR systems due to the existence of the interference constraints and can be modified to get a suboptimal solution as follows

1. **Fix the subcarriers powers:** assume that the interference induced to the primary system is divided uniformly on the subcarriers, i.e. every subcarrier is able to induce interference to PU equal to  $\frac{I_{th}}{N}$ . Therefore, from (5.2), the maximum power that can be allocated to the  $j^{th}(k^{th})$  subcarrier in source(destination) side is

$$P_j^{max}(P_k^{max}) = \frac{I_{th}}{N\Omega_j(\Omega_k)} \quad (5.27)$$

Remark that the subscript  $m$  is removed since we are considering the single relay case. Similarly, the power constraints can be distributed uniformly on the different subcarriers to get

$$P_j^{uni}(P_k^{uni}) = \frac{P_S(P_R)}{N} \quad (5.28)$$

and hence, the allocated power to the  $j^{th}(k^{th})$  subcarrier is

$$P_S^j(P_{RD}^k) = \min(P_j^{max}(P_k^{max}), P_j^{uni}(P_k^{uni})) \quad (5.29)$$

2. **Match the subcarriers:** The already fixed powers in (5.29) are considering the interference and the power constraints, therefore, the channel qualities should be considered also in order to achieve a good subcarrier matching criteria. Hence, the subcarriers in the source and destination sides are ordered according to the product of the powers found using (5.29) and the channel gains, i.e.  $P_S^j(P_{RD}^k) \times H_{SR}^j(H_{RD}^k)$ . Afterwards, every subcarrier in the source side is matched with the subcarrier with the same order in the destination side.
3. **Re-adjust the assigned powers:** given the subcarrier matching found by the previous step, the original optimization problem can be solved to find the optimal power allocation vector according to this matching. In the case when the transmit powers of the CR system is limited by the interference constraints only where the available power budgets is high enough, the algorithm described in chapter 3 can be adopted in this step in order to find the solution efficiently as described in Appendix 5.A.1.

## 5.6 Simulation Results

The simulations are performed under the scenario given in Fig.5.1. A multicarrier system of  $N = 64$  subcarriers is assumed. The values of  $T_s$  and  $\Delta f$  are assumed to be  $4\mu$  seconds and 0.3125 MHz respectively. The OFDM system is assumed to have a 6.67% of its symbol time as cyclic prefix (CP). For FBMC system, the prototype coefficients are assumed to be equal to PHYDYAS coefficients with overlapping factor  $K = 4$  and are defined by (2.16) and (2.17). The channel gains are outcomes of independent Rayleigh distributed random variables with mean equal to 1. All the results have been averaged over 1000 iterations. In the simulations, the following algorithms are considered

1. **Optimal with direct:** apply the solution based on the dual decomposition technique presented in Sec. 5.3.
2. **Optimal without direct:** apply the solution based on the dual decomposition technique presented in Sec. 5.3 when the relayed transmission is allowed only while the direct link is always blocked, i.e. the direct/relayed transmission indicator  $\alpha_j$  is assumed to be  $\alpha_j = 1, \forall j$ .
3. **Suboptimal:** apply the proposed suboptimal algorithm described in Sec. 5.5.
4. **SNR:** the subcarriers are paired and assigned to the relays based on their SNR. The powers are evaluated by solving (5.9) with the known values of  $\alpha_j, t_{j,k}$  and  $\pi_{j,k}^m$ .
5. **Random:** the subcarriers are paired and assigned to the relays randomly. The powers are evaluated by solving (5.9) with the known values of  $\alpha_j, t_{j,k}$  and  $\pi_{j,k}^m$ .

The simulation considers two different cases, the first case deal with multi-relay system which is able to use either the relayed or direct transmission while the second case considers the relayed transmission in single relay CR system under both the interference and power constraint, and under the interference constraint only.

### 5.6.1 Case 1: Multi-relay CR System with Direct Link Transmission Ability

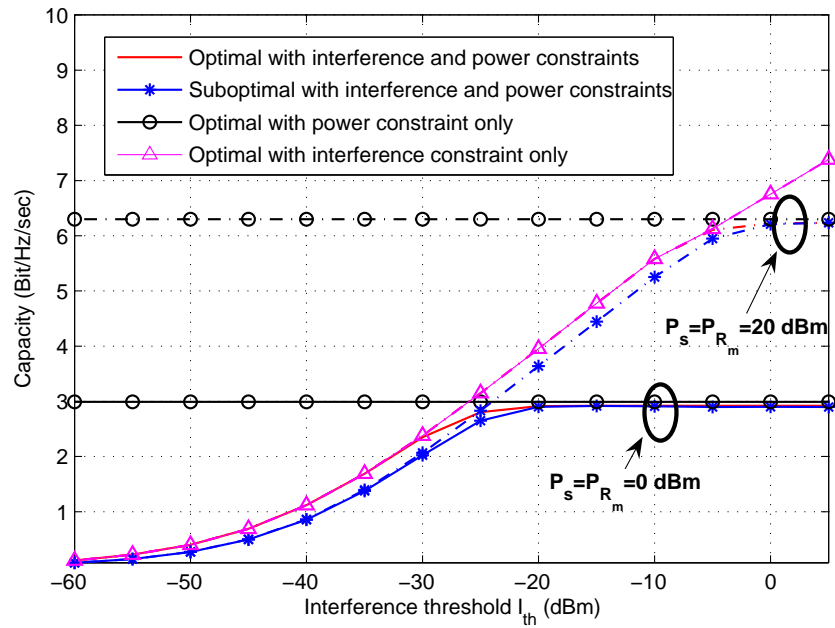
Consider an OFDM based CR system with  $M = 5$  relays. Fig. 5.2 depicts the achieved capacity of the optimal and suboptimal schemes vs. the interference constraint. The solid lines plots the case when  $P_S = P_R = 0$  dBm, while the dashed ones when  $P_S = P_R = 20$  dBm. The achieved capacity is compared with that when only one of interference or power constraint is applied. The interference (power) only performance forms an upper bound for that with both constraints. To that end, the performance of the optimal solution under both constraints has three different regions. Considering the case of  $P_S = P_R = 0$  dBm, the three region could be explained as follows

1. If  $I_{th} \leq -30$  dBm : the performance is equal to that of the interference only case. The limited effect of the power constraints comes from the small value of the allowed interference since only a small quantity of the available power can induce the maximum allowed interference.
2. If  $I_{th} \geq -20$  dBm : the performance is equal to that of the power only. The system in this region performs like a non-cognitive one since the available power budgets cannot induce the maximum allowed interference threshold.
3. If  $-30 < I_{th} \leq -20$  dBm : in this region both the power and interference constraints are affecting the optimization problem. The optimal solution performs close to the upper bound formed by the interference (power) only curves.

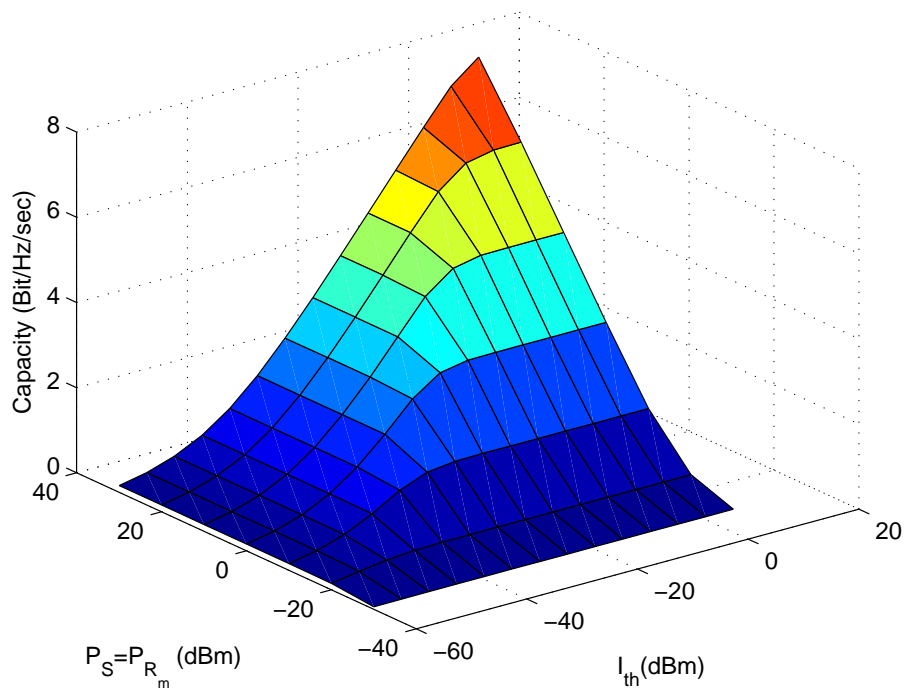
The same observations can be applied on the case of  $P_S = P_R = 20$  dBm but with different ranges of the regions.

To more clarify the different regions, Fig. 5.3 plots the *optimal with direct* achieved capacity for different interference and power constraints. By fixing one of the constraints, one can see that the achieved capacity increases with the other up to certain point. After this point, the change of the constraint value does not affect the achieved capacity. This is can be justified as follows

1. With fixed power constraint, the CR capacity become constant because the induced interference to the primary system using the fixed power budget is equal or lower than the



**Figure 5.2:** Achieved capacity vs allowed interference threshold. The solid lines when  $P_S = P_R = 0$  dBm while the dashed ones when  $P_S = P_R = 20$  dBm.

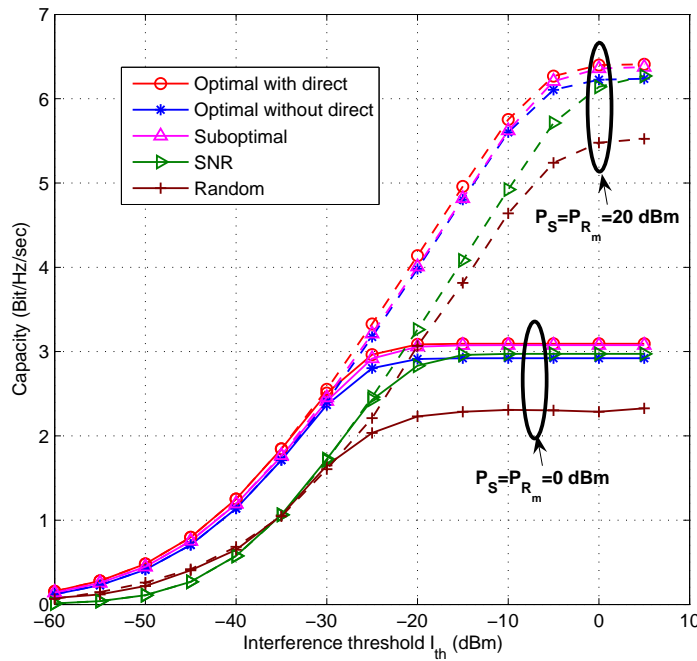


**Figure 5.3:** Achieved capacity vs allowed interference thresholds and power budget constraints.

maximum interference specified by the interference constraint.

2. With fixed interference constraint, the CR capacity become constant because the increment in the available power will not be used by the CR system where the maximum power that can be used without violating the interference constraint is reached at this point.

Fig. 5.4 shows the achieved capacity of the different algorithms vs. the interference threshold. It can be noticed that the capacity is increased by considering the relayed transmission with ability of using the direct link in some subcarriers. Moreover, the CR system capacity increases with the interference threshold as the CR system become able to use more power on the different subcarriers. Additionally, the throughput increases -as expected- with the increase of the available power budgets. However, the increment in the throughput by changing the available power from 0 dBm to 20 dBm is very small when the interference threshold is low since both systems use approximately the same amount of power to induce the maximum allowed interference to the PU. Moreover, the *suboptimal* algorithm with low computational complexity has a near optimal performance and outperforms *SNR* and *random* algorithms. It is worth mention-

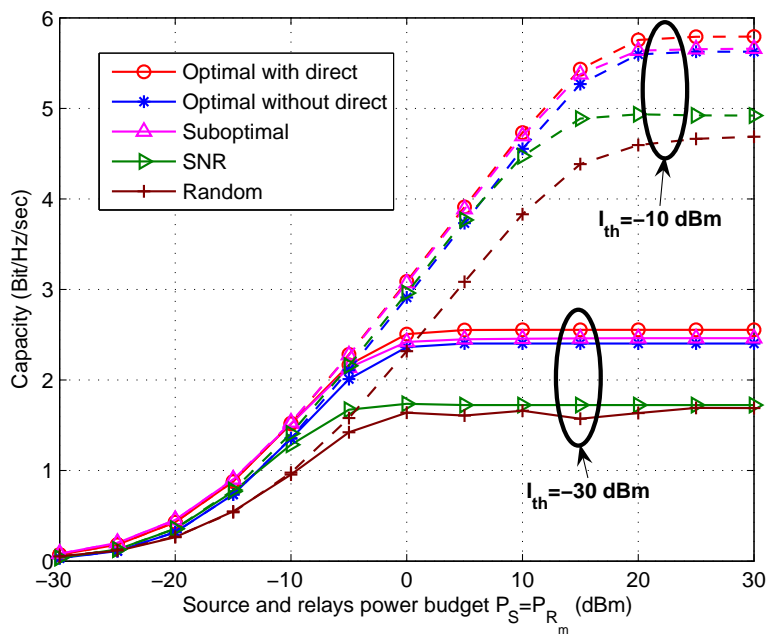


**Figure 5.4:** Achieved capacity vs the interference threshold. The solid lines when with  $P_S = P_{R_m} = 0$ . dBm while the dashed ones when with  $P_S = P_{R_m} = 20$ . dBm.

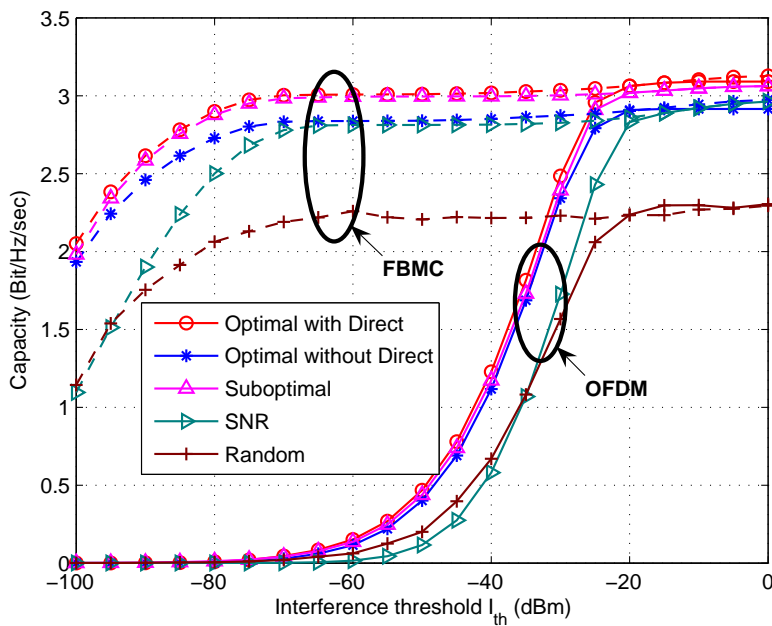
ing that the performance loss of the *suboptimal* algorithm relative to the *optimal with direct* one is caused by different factors. In the *suboptimal* algorithm, the available power budgets in the source and the destination are distributed equally between the subcarrier which is not always optimal depending on whether the system is operating on high or low SNR. Moreover, the step ladder power allocation in which every subcarrier is assumed to induce the same amount of interference to the PU is shown to create some performance degradation as presented in [34]. Additionally, the *suboptimal* algorithm performs the subcarrier pairing and the power allocation in sequential way starting from the first subcarrier up to the last one. When a given subcarrier in the source side is paired with another one in destination side, the latter cannot be used anymore for the next steps. Hence, the order of the subcarrier assignment process may slightly degrades the performance of the *suboptimal* scheme. In the low interference thresholds region, the *SNR*-based matching criteria applied in the non-cognitive system has limited performance in comparison with *optimal* because it does not take the interference to the primary system into account. Furthermore, the gap between the *optimal* algorithm and the *SNR* algorithm is decreased with the interference threshold as the system behaves closer to the non-cognitive one. The same interpretation can be applied on Fig. 5.5 in which the achieved capacities are plotted vs. the available power budgets in the source and the relays. In this figure, the non-cognitive behavior lies on the low power region where the available power budgets are not able to induce the pre-specified interference threshold.

To compare the performance of OFDM and FBMC based system in cooperative relay networks, Fig. 5.6 and Fig. 5.7 plot the achieved capacity of the algorithms against different interference thresholds and different power constraints, respectively. In Fig. 5.6, two different performance regions can be identified as follows

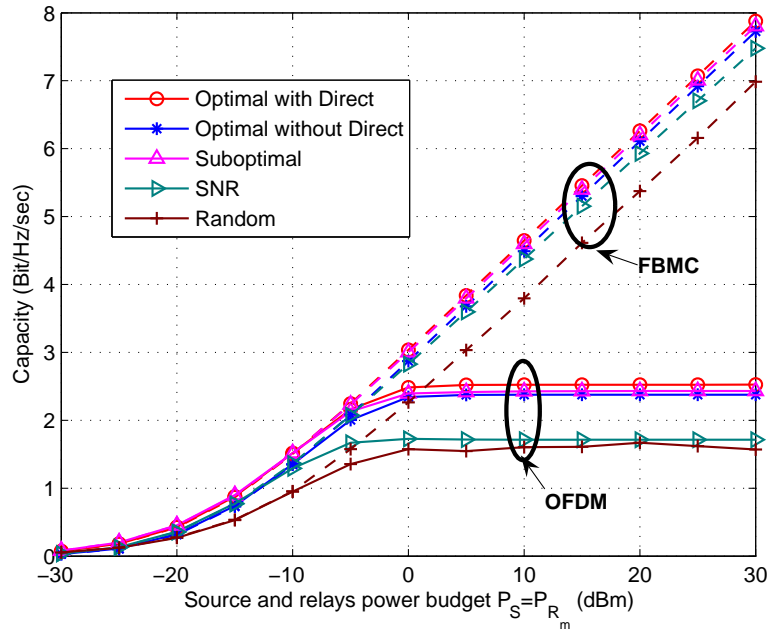
1. When  $I_{th} \leq -30$  dBm: the capacity of the FBMC based CR systems is more that that of the OFDM based ones. This is because of the small sidelobes of the FBMC systems as well as because of loss of the spectrum efficiency in OFDM due to the use of the CP. Therefore, the interference constraint generally has small effect on the performance of the FBMC based systems which is not the case in OFDM ones.
2. When  $I_{th} > -30$  dBm: both of the system has almost the same performance when operating with high interference thresholds or low power budgets. This is can be justified by noting that the systems in this region operate in noncognitive-like environment.



**Figure 5.5:** Achieved capacity vs available power budget with  $P_S = P_{R_m}$ . The solid lines when  $I_{th} = -30$  dBm while the dashed ones when  $I_{th} = -10$  dBm.



**Figure 5.6:** Achieved capacity vs the interference threshold with  $P_S = P_{R_m} = 0$  dBm. OFDM based system is plotted by the solid lines while the dashed ones represent the FBMC based systems



**Figure 5.7:** Achieved capacity vs available power budget with  $P_S = P_{R_m}$  when  $I_{th} = -30$  dBm. OFDM based system is plotted by the solid lines while the dashed ones represent the FBMC based systems.

Similarly, in Fig. 5.7, the region when  $P_S = P_{R_m} \leq -5$  dBm represents the noncognitive-like environment; where the available power budget is not able to introduce high interference. When the power constraints increase more than this value, FBMC system has significantly improves the CR capacity since FBMC based systems can use more transmission power which increase the total system capacity.

### 5.6.2 Case 2: Single-relay CR System with Blocked Direct Link Transmission

In this case, only one relay is considered to assist the transmission where the direct link between the source and the destination is blocked. In addition to the *suboptimal* and *SNR* which is defined previously in the beginning of this section, the following algorithms are considered

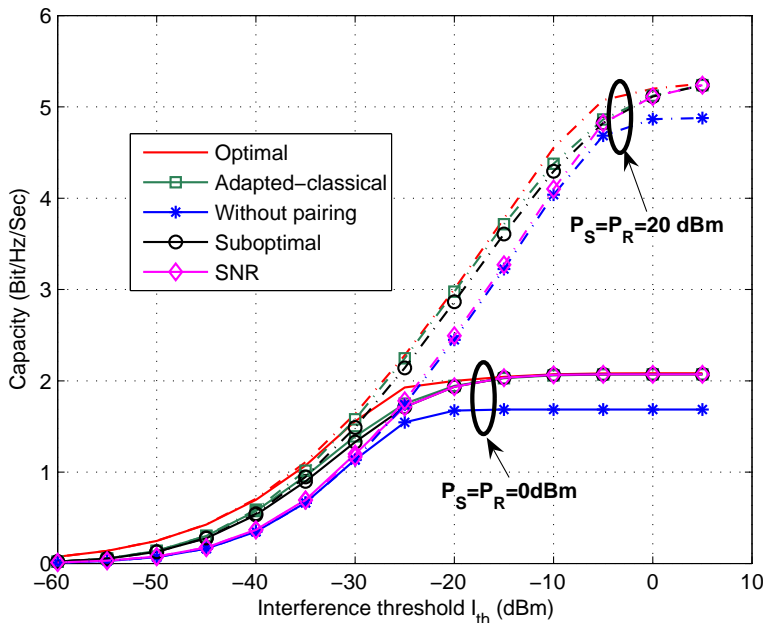
1. **Optimal:** apply the solution based on the dual decomposition technique presented in Sec. 5.3 considering one relay and relayed transmission only.
2. **Adapted-classical:** apply the scheme proposed at the end of Sec. 5.5 by adapting the



scheme used in non-cognitive systems.

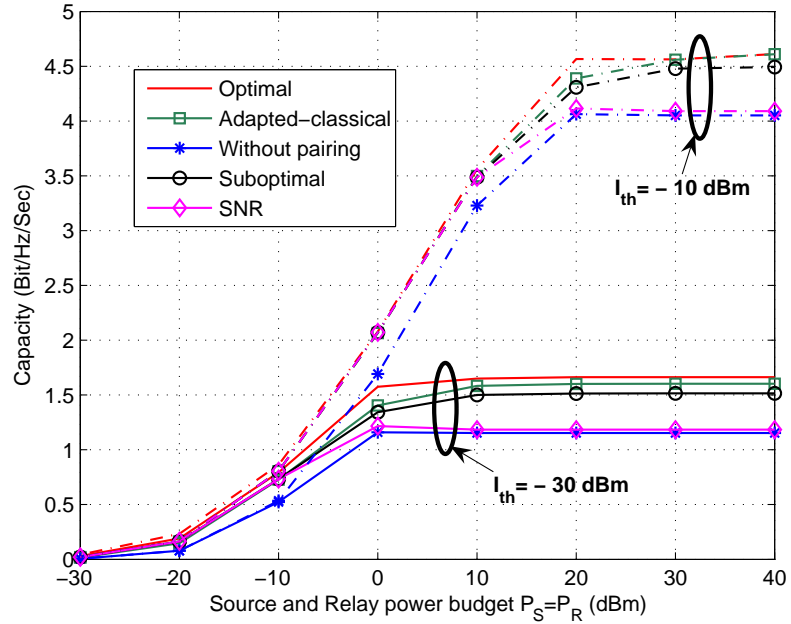
3. **Without pairing:** assume that the data transmitted by the source over a given subcarrier in the first time slot is forwarded by the relay over the same subcarrier in the second time slot. The powers are evaluated by solving the optimization problem with  $t_{j,k} = 1$  for every  $j = k$  and zero otherwise.

Fig. 5.8 and Fig. 5.9 show the achieved capacity of the different algorithms vs. the interference threshold and the available power budgets respectively. In addition to the comments about the previous figures, we can notice that the performance of the *adapted-classical* has more computational complexity than the *suboptimal* algorithm and its performance lies between the *optimal* and the *suboptimal* algorithms. Moreover, the limited performance of the *without pairing* algorithm confirms the performance enhancement that gained by allowing the subcarrier pairing. Remark that as the interference constraint increases, the SNR algorithm and the *adapted-classical* algorithms become very close to the optimal solution. This is because the system with high interference constraint work in the noncognitive-like region, where the subcarrier pairing according the channel qualities is optimal.

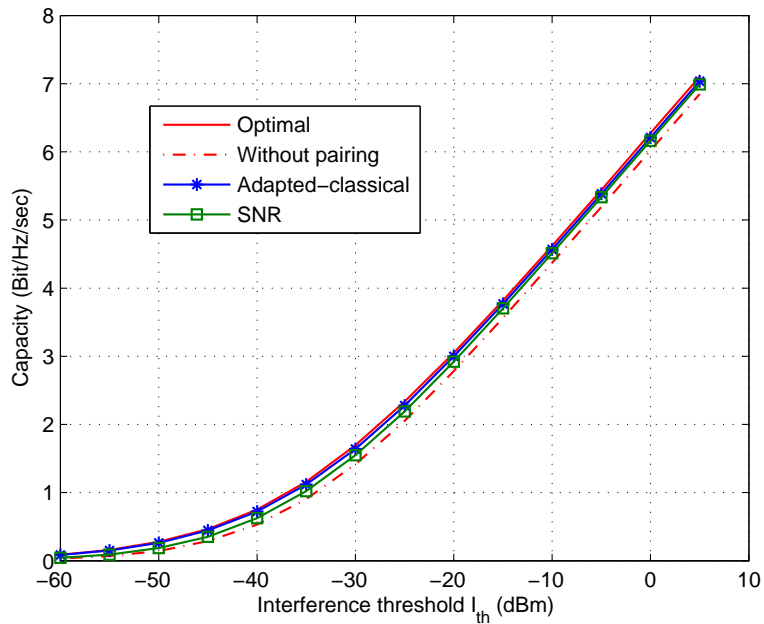


**Figure 5.8:** Achieved capacity vs the interference threshold in single-relay CR system. The solid lines when with  $P_S = P_{R_m} = 0$ . dBm while the dashed ones when with  $P_S = P_{R_m} = 20$ . dBm.

Fig. 5.10 plots the average capacity of the CR system vs. the interference threshold when there is no power budget limit, i.e. interference constraint only. The *adapted-classical*



**Figure 5.9:** Achieved capacity vs available power budget with  $P_S = P_{R_m}$  in single-relay CR system. The solid lines when  $I_{th} = -30$  dBm while the dashed ones when  $I_{th} = -10$  dBm.



**Figure 5.10:** Achieved capacity vs the interference threshold in single-relay CR system with interference constraint only.

here apply the scheme proposed at the end of Sec. 5.5 and use the power allocation strategy described in Appendix 5.A.1. The *adapted-classical* algorithm has a close performance to optimal algorithm and performs better than the other algorithms which confirm the efficiency of the applied scheme. The *without pairing* algorithm has the worst performance which reveals the importance of the subcarrier matching in the relay networks. Remark that the performance of the SNR algorithm is enhanced by increasing the interference constraint due to the optimality of this scheme in the non-cognitive radio scenario.

## 5.7 Chapter Summary and Conclusions

In this chapter, we have considered the resource allocation problem in multi-relay multicarrier based CR system. Two time slot transmission is considered where the relays employ the DF strategy. The objective is to maximize the CR achieved capacity while maintain the interference introduced to the primary system in every time slot below a pre-specified threshold. Additionally, the separate source and per-relay power constraints are considered. The source can transmit to the destination directly or via relay. The problem is a mixed integer programming problem which is hard to solve. Therefore, the dual decomposition technique is used to find jointly the subcarrier pairing, relay assignment and power allocation. Based on the result that when the time sharing constraint is satisfied, and the number of subcarrier is high enough, the duality gap between the solution of the primal and the dual problems is zero regardless of the convexity of the problem. Accordingly, the solution of the dual problem is asymptotically optimal. The dual decomposition technique evaluates iteratively the solution where the subgradient method is used to update the different dual variables. In each iteration, the power levels are determined firstly for every relay and subcarrier pair in case of relayed transmission and for every subcarrier in the source side in case of direct transmission. Afterwards, the best relay is selected for a given subcarrier pair in the relayed transmission. Based on that, the profit of the relayed and direct transmission is compared and finally the Hungarian method is used to find the optimal subcarrier pairs as well as to determine the subcarriers used for the direct transmission. The iterations are repeated until convergence.

To reduce the computational complexity of the dual decomposition technique, a greedy suboptimal algorithm is proposed to allocate the different resources jointly. The suboptimal

algorithm starts with evaluating the achieved capacity by allocating a given subcarrier in the source side to a specific relay. To avoid the capacity imbalance in the source to relay and the relay to destination links, the power required to achieve the same rate in both sides is determined. Afterwards, the limitation of the power and interference constraint is considering by choosing the minimum allowable power and then the best subcarrier pair and relay are determined for every subcarrier and relay. Finally, the direct transmission is selected if its achieved capacity is better than the relayed one. The suboptimal algorithm achieves a near optimal performance with much less complexity and outperforms the SNR and random based methods. The suboptimal algorithm reduces the complexity from  $O(T(MN^2 + M(N!) + 2N + N^3))$  required by the dual decomposition technique to  $O(MN + MN^2)$ . The performance of the different algorithms as well as the impact of the different constraints on the system capacity is discussed in the simulation part. Additionally, the capacities achieved by OFDM and FBMC based systems is compared to prove the efficiency of using FBMC in the CR systems.

## 5.A Appendix

### 5.A.1 Power Allocation Under the Interference Constraint Only with Known Subcarrier Pairs

By applying the subcarrier pairing step and ordering the subcarriers in the source and the relay sides, the subcarrier index in both sides can be changed from  $j$  and  $k$  to  $i$  for notation simplicity, i.e. the  $i^{th}$  subcarrier in the source side is paired with the  $i^{th}$  subcarrier in destination side. Therefore, the power optimization problem can be written as follows

$$\begin{aligned}
 & \max_{P_S^i > 0} \sum_{i=1}^N \frac{1}{2} \log_2 (1 + P_S^i H_{SR}^i) \\
 & s.t. \quad - \text{(Interference in the first time slot):} \\
 & \quad \sum_{i=1}^N P_S^i \Omega_S^i \leq I_{th}; \\
 & \quad - \text{(Interference in the second time slot):} \\
 & \quad \sum_{i=1}^N \frac{P_S^i H_{SR}^i}{H_{RD}^i} \Omega_R^i \leq I_{th};
 \end{aligned} \tag{5.30}$$

The above problem is a convex optimization problem. Applying the KKT conditions and solving for the optimal power, we can get

$$P_S^{i*} = \left[ \frac{1}{\eta \Omega_S^i + \gamma \frac{H_{SR}^i}{H_{RD}^i} \Omega_R^i} - \frac{1}{H_{SR}^i} \right]^+ \tag{5.31}$$

where  $\eta, \gamma$  are the non-negative Lagrange multipliers. Solving for multiple Lagrange multipliers is still computationally complex. To develop a computationally efficient power allocation algorithm, the following stages can be performed

- **Maximum power determination:** we can commence by assuming that the maximum power that can be allocated to each subcarrier  $P_{max}^i$  is determined subject to the interference constraint in the first time slot only. Therefore, the following problem is addressed

$$\begin{aligned}
 & \max_{P_{S(T1)}^i > 0} \sum_{i=1}^N \frac{1}{2} \log_2 (1 + P_{S(T1)}^i H_{SR}^i) \\
 & s.t. \quad \sum_{i=1}^N P_{S(T1)}^i \Omega_S^i \leq I_{th}
 \end{aligned} \tag{5.32}$$

where  $(T1)$  stands for optimization under the interference constraint in the first time slot

only. Following the analysis given in [34], we get

$$\begin{aligned} P_{S(T1)}^i &= \left[ \frac{1}{\lambda_1 \Omega_S^i} - \frac{1}{H_{SR}^i} \right]^+ \\ \lambda_1 &= \frac{|N|}{I_{th} + \sum_{i=1}^N \frac{\Omega_S^i}{H_{SR}^i}} \end{aligned} \quad (5.33)$$

where  $\lambda_1$  is the non-negative Lagrange multiplier.

- **Interference in the second time slot testing:** once the maximum allowed power is determined, i.e.  $P_{max}^i = P_{S(T1)}$ , the interference in the second time slot is tested to check whether  $\sum_{i=1}^N (P_{max}^i H_{SR}^i \Omega_R^i) / H_{RD}^i \leq I_{th}$  holds or not. If the relation holds, then the solution is found where  $P_S^{i*} = P_{max}^i$ . Otherwise, the next step is performed.
- **Interference in the second time slot consideration:** the power should be distributed according to the interference in the second time slot only given that the power allocated to each subcarrier is lower than or equal to  $P_{max}^i$ . Hence, the following problem should be solved

$$\begin{aligned} \max_{P_{S(W.F)}^i} \quad & \sum_{i=1}^N \frac{1}{2} \log_2 \left( 1 + P_{S(W.F)}^i H_{SR}^i \right) \\ \text{s.t.} \quad & \sum_{i=1}^N \frac{P_{S(W.F)}^i H_{SR}^i \Omega_R^i}{H_{RD}^i} \leq I_{th} \\ & 0 \leq P_{S(W.F)}^i \leq P_{max}^i \end{aligned} \quad (5.34)$$

The former problem can be solved efficiently by using the concept of the "cap-limited" waterfilling [41]. If the interference in the second time slot is considered only, the following optimization problem is formulated

$$\begin{aligned} \max_{P_{S(T2)}^i > 0} \quad & \sum_{i=1}^N \frac{1}{2} \log_2 \left( 1 + P_{S(T2)}^i H_{SR}^i \right) \\ \text{s.t.} \quad & \sum_{i=1}^N \frac{P_{S(T2)}^i H_{SR}^i \Omega_R^i}{H_{RD}^i} \leq I_{th} \end{aligned} \quad (5.35)$$

where (T2) stands for optimization under the interference constraint in the second time slot only. The solution can be given as follows

$$\begin{aligned} P_{S(T2)}^i &= \left[ \frac{1}{(\lambda_2 H_{SR}^i \Omega_R^i) / H_{RD}^i} - \frac{1}{H_{SR}^i} \right]^+ \\ \lambda_2 &= \frac{|N|}{I_{th} + \sum_{i=1}^N \frac{\Omega_R^i}{H_{SR}^i}} \end{aligned} \quad (5.36)$$

where  $\lambda_2$  is the non-negative Lagrange multiplier. Given the initial solution evaluated by (5.36), the channels that violate the maximum power  $P_{max}^i$  are determined and upper

bounded with  $P_{max}^i$ . The total interference  $I_{th}$  is reduced by subtracting the interference induced by the powers assigned so far. At the next step, the algorithm proceeds to successive applying of (5.36) over the subcarriers that did not violate the maximum power  $P_{max}^i$  in the last step. These procedures are repeated until the allocated power  $P_{S(W.F)}^i$  doesn't violate the maximum power  $P_{max}^i$  in any of the subcarriers in the new iteration.

- **Power levels re-adjustment:** The solution  $P_{S(W.F)}^i$  satisfies the interference constraint in the second time slot with equality which is not the case for the interference constraint in the first time slot. Since it's assumed that  $P_{S(W.F)}^i \leq P_{max}^i$ , some of the powers allocated to subcarriers is not reaching the maximum allowable values which make the interference introduced to the PU system in the first time slot below the threshold  $I_{th}$ . In order to take advantage of the allowable interference, some power can be taken from one subcarrier and given to another hoping to increase the total system capacity. Therefore, the values of the maximum power that can be allocated to each subcarrier  $P_{max}^i$  should be updated depending on the left interference. The left interference can be determined as follows

$$I_{Left} = I_{th} - \sum_{i=1}^N P_{S(W.F)}^i \Omega_S^i \quad (5.37)$$

Assuming that  $\mathcal{S} \subset N$  is the set of the subcarriers whose power  $P_{S(W.F)}$  that reach the maximum  $P_{max}^i$ , i.e.  $P_{S(W.F)}^i = P_{max}^i, \forall i \in \mathcal{S}$ , then,  $P_{max}^i, \forall i \in \mathcal{S}$  can be updated by applying (5.33) on the subcarriers in the set  $\mathcal{S}$  with the following interference constraints

$$I_{updated} = I_{Left} + \sum_{i \in \mathcal{S}} P_{S(W.F)}^i \Omega_S^i \quad (5.38)$$

After determining the updated values of  $P_{max}^i$ , (5.34) is solved again to find the final solution  $P_S^{i*} = P_{S(W.F)}^i$ .

## Bibliography

- [1] O. Simeone, Y. Bar-Ness, and U. Spagnolini, “Stable throughput of cognitive radios with and without relaying capability,” *IEEE Transactions on Communications*, vol. 55, no. 12, pp. 2351–2360, Dec. 2007.
- [2] S. Golrezaei-Khuzani and M. Nasiri-Kenari, “Orthogonal frequency division multiple access-based cognitive radio networks with relaying capability,” *IET Communications*, vol. 4, no. 4, pp. 395–409, Mar. 2010.
- [3] Tao Luo, Fei Lin, Tao Jiang, M. Guizani, and Wen Chen, “Multicarrier modulation and cooperative communication in multihop cognitive radio networks,” *IEEE Wireless Communications*, vol. 18, no. 1, pp. 38–45, Feb. 2011.
- [4] Wenyi Wang, Shefeng Yan, and Shuyuan Yang, “Optimally joint subcarrier matching and power allocation in OFDM multihop system,” *EURASIP Journal on Advances in Signal Processing*, vol. 2008, January 2008.
- [5] Wenyi Wang and Renbiao Wu, “Capacity maximization for OFDM two-Hop relay system with separate power constraints,” *IEEE Transactions on Vehicular Technology*, vol. 58, no. 9, pp. 4943–4954, Nov. 2009.
- [6] H. Boostanimehr, O. Duval, V.K. Bhargava, and F. Gagnon, “Selective subcarrier pairing and power allocation for decode-and-Forward OFDM relay systems,” in *IEEE International Conference on Communications (ICC)*, May 2010, pp. 1–5.
- [7] Luc Vandendorpe, Jérôme Louveaux, Onur Oguzand, and Abdellatif Zaidi, “Rate-optimized power allocation for DF-Relayed OFDM transmission under sum and individual power constraints,” *EURASIP Journal on Wireless Communications and Networking*, vol. 2009, Article ID 814278, 11 pages, 2009.
- [8] Hong-Xing Li, Hui Yu, Han-Wen Luo, Jia Guo, and Chisheng Li, “Dynamic subchannel and power allocation in OFDMA-Based DF cooperative relay networks,” in *IEEE Global Telecommunications Conference (GLOBECOM'08)*, Nov. 2008, pp. 1–5.



- [9] Wenbing Dang, Meixia Tao, Hua Mu, and Jianwei Huang, "Subcarrier-pair based resource allocation for cooperative multi-relay OFDM systems," *IEEE Transactions on Wireless Communications*, vol. 9, no. 5, pp. 1640–1649, May 2010.
- [10] Chih-Ning Hsu, Hsuan-Jung Su, and Pin-Hsun Lin, "Joint subcarrier pairing and power allocation for OFDM transmission with decode-and-forward relaying," *IEEE Transactions on Signal Processing*, vol. 59, no. 1, pp. 399–414, Jan. 2011.
- [11] Tao Wang and Luc Vandendorpe, "Sum rate maximized resource allocation in multiple DF relays aided OFDM transmission.," *IEEE Journal on Selected Areas in Communications*, vol. 29, no. 8, pp. 1559–1571, 2011.
- [12] Wanlu Sun, Lihua Li, Wei Yang, and Lei Song, "Joint subcarrier pairing, relay selection and power allocation in OFDM relay systems," in *IEEE International Conference on Communications (ICC)*, June 2011, pp. 1–5.
- [13] N. Zhou, X. Zhu, and Y. Huang, "Optimal asymmetric resource allocation and analysis for OFDM-based multideestination relay systems in the downlink," *IEEE Transactions on Vehicular Technology*, vol. 60, no. 3, pp. 1307–1312, 2011.
- [14] M. Hajiaghayi, Min Dong, and Ben Liang, "Jointly optimal channel pairing and power allocation for multichannel multihop relaying," *IEEE Transactions on Signal Processing*, vol. 59, no. 10, pp. 4998–5012, Oct. 2011.
- [15] J. Mietzner, L. Lampe, and R. Schober, "Distributed transmit power allocation for multihop cognitive-radio systems," *IEEE Transactions on Wireless Communications*, vol. 8, no. 10, pp. 5187–5201, October 2009.
- [16] J. Jia, J. Zhang, and Q. Zhang, "Cooperative relay for cognitive radio networks," in *IEEE INFOCOM 2009*, Apr. 2009, pp. 2304–2312.
- [17] T. Nadkar, V. Thumar, U.B. Desai, and S.N. Merchant, "Judicious power loading for a cognitive relay scenario," in *International Symposium on Intelligent Signal Processing and Communication Systems (ISPACS 2009)*, Jan. 2009, pp. 327–330.

- [18] T. Nadkar, V. Thumar, U.B. Desai, and S.N. Merchant, "Optimum bit loading for cognitive relaying," in *IEEE Wireless Communications and Networking Conference (WCNC'10)*, Apr. 2010, pp. 1–6.
- [19] Yin Sun, Yunzhou Li, Xiaofeng Zhong, Shidong Zhou, and Xibin Xu, "Resource allocation for the cognitive coexistence of ad-hoc and cooperative relay networks," in *IEEE International Conference on Communications (ICC)*, May 2010, pp. 1–5.
- [20] Changqing Luo, F.R. Yu, Hong Ji, and V. C. M. Leung, "Distributed relay selection and power control in cognitive radio networks with cooperative transmission," in *IEEE International Conference on Communications (ICC'10)*, May. 2010, pp. 1–5.
- [21] Liying Li, Xiangwei Zhou, Hongbing Xu, G.Y. Li, D. Wang, and A. Soong, "Simplified relay selection and power allocation in cooperative cognitive radio systems," *IEEE Transactions on Wireless Communications*, vol. 10, no. 1, pp. 33–36, 2011.
- [22] Guodong Zhao, Chenyang Yang, G.Y. Li, Dongdong Li, and A.C.K. Soong, "Power and channel allocation for cooperative relay in cognitive radio networks," *IEEE Journal of Selected Topics in Signal Processing*, vol. 5, no. 1, pp. 151–159, 2011.
- [23] B. Farhang-Boroujeny and R. Kempter, "Multicarrier communication techniques for spectrum sensing and communication in cognitive radios," *IEEE Commun. Mag. (Special Issue on Cognitive Radios for Dynamic Spectrum Access)*, vol. 48, no. 4, pp. 80–85, Apr. 2008.
- [24] Haijian Zhang, Didier LE Ruyet, and Michel Terre, "On spectral efficiency analysis between OFDM/OQAM and OFDM based CR networks," in *Vehicular Technology Conference (VTC'09-Spring)*, Barcelona-Spain, 2009.
- [25] M. Shaat and F. Bader, "Asymptotically optimal resource allocation in OFDM-based cognitive networks with multiple relays," *accepted in IEEE Transactions on Wireless Communications*.
- [26] M. Shaat and F. Bader, "Optimal power allocation algorithm for OFDM-Based decode-and-Forward dual-Hop cognitive systems," in *IEEE 73rd Vehicular Technology Conference (VTC Spring)*, May 2011, pp. 1–5.

- [27] M. Shaat and F. Bader, "Optimal and suboptimal resource allocation for two-Hop OFDM-Based multi-Relay cognitive networks," in *IEEE 22nd International Symposium on Personal, Indoor and Mobile Radio Communications (PIMRC'11)*, Toronto-Canada, Sept. 2011, pp. 477–481.
- [28] M. Shaat and F. Bader, "Optimal resource allocation in multi-Relay cognitive networks using dual decomposition," in *ICT-ACROPOLIS Network of Excellence Workshop on "Cognitive Radio and Networking: Challenges and Solutions Ahead" jointly located with IEEE 22nd International Symposium on Personal, Indoor and Mobile Radio Communications (PIMRC'11)*, Toronto-Canada, Sept. 2011, pp. 2335–2339.
- [29] M. Shaat and F. Bader, "Joint subcarrier pairing and power allocation for DF-Relayed OFDM cognitive systems," in *IEEE Global Telecommunications Conference (GLOBECOM'11)*, Houston-USA, Dec. 2011.
- [30] M. Shaat and F. Bader, "Joint resource optimization in decode and forward multi-relay cognitive network with direct link," *Submitted to IEEE Wireless Communications and Networking Conference, (WCNC'12)*, Apr. 2012.
- [31] T. Weiss and J. Hillenbrand, "Mutual interference in OFDM-based spectrum pooling systems," in *Vehicular Technology Conference (VTC'04-Spring)*, May 2004, vol. 4.
- [32] "PHYDYAS-Physical layer for dynamic spectrum access and cognitive radio," Project website: [www.ict-phydyas.org](http://www.ict-phydyas.org).
- [33] M. Bellanger, "Filter banks and OFDM-OQAM for high throughput wireless LAN," in *3rd International Symposium on Communications, Control and Signal Processing (IS-CCSP'08)*, March 2008, pp. 758–761.
- [34] G. Bansal, M. J. Hossain, and V. K. Bhargava, "Optimal and suboptimal power allocation schemes for OFDM-based cognitive radio systems," *IEEE Transactions on Wireless Communications*, vol. 7, no. 11, pp. 4710–4718, November 2008.
- [35] Cheng-Xiang Wang, Hsiao-Hwa Chen, Xuemin Hong, and M. Guizani, "Cognitive radio network management," *IEEE Vehicular Technology Magazine*, vol. 3, no. 1, pp. 28–35, March 2008.

- [36] P. Gong, P. Xue, D. Park, and D. K. Kim, "Optimum power allocation in a nonorthogonal amplify-and-forward relay-assisted network," *IEEE Transactions on Vehicular Technology*, vol. 60, no. 3, pp. 890–900, 2011.
- [37] Rui Zhang, Shuguang Cui, and Ying-Chang Liang, "On ergodic sum capacity of fading cognitive multiple-access and broadcast channels," *IEEE Transactions on Information Theory*, vol. 55, no. 11, pp. 5161–5178, Nov. 2009.
- [38] Wei Yu and R. Lui, "Dual methods for nonconvex spectrum optimization of multicarrier systems," *IEEE Transactions on Communications*, vol. 54, no. 7, pp. 1310–1322, 2006.
- [39] Harold W. Kuhn, "The hungarian method for the assignment problem," in *50 Years of Integer Programming 1958-2008*, pp. 29–47. Springer Berlin Heidelberg, 2010.
- [40] S. Boyd and A. Mutapcic, "Subgradient methods," *notes for EE364, Stanford University*, Winter. 2006-07.
- [41] Chengshi Zhao and Kyungsup Kwak, "Power/Bit loading in OFDM-Based cognitive networks with comprehensive interference considerations: The single-SU case," *IEEE Transactions on Vehicular Technology*, vol. 59, no. 4, pp. 1910–1922, May 2010.



## General Conclusions and Future Work

*"Not knowing when the dawn will come, I open every door"* **Emily Dickinson.**

### Contents

---

<b>6.1</b>	<b>Conclusions . . . . .</b>	<b>178</b>
<b>6.2</b>	<b>Future Work . . . . .</b>	<b>181</b>
	<b>Bibliography . . . . .</b>	<b>185</b>

---

This dissertation has tackled the resource management problem in multicarrier based cognitive radio (CR) systems. Specifically, three scenarios have been considered: downlink transmission, uplink transmission, and relay assisted transmission. For the different scenarios, the optimal solution of the problem is investigated and low complexity efficient algorithms are proposed. Furthermore, the impact of the different constraints is studied. Eventually, the performance of using orthogonal frequency division multiplexing (OFDM) and filter bank multicarrier (FBMC) in the CR physical layer is compared. The following assumptions are always considered in this dissertation: *i*) the channel state information (CSI) is known at the cognitive base station (CBS) -or at the source in the relayed transmission- which is in charge of performing the resource allocation process. *ii*) the CSI as well as the channel occupancy status are assumed to be constant during the frame transmission. In the following, the main results of each chapter and some future work points are summarized.

## 6.1 Conclusions

### Chapter 3

In this chapter, the downlink scenario is considered. The objective is to maximize the capacity achieved by the CBS subject to the total power and interference constraints. As the problem is formulated as a mixed-integer optimization problem which is hard to solve, a two step algorithm is applied in order to reduce the computational complexity. The subcarriers are assigned sequentially to the user with the maximum signal to noise ratio (SNR) in the first step, while the available power budget is allocated to different subcarriers in the second step. To further reduce the computational complexity of the power allocation part, every subcarrier is assumed to belong to the nearest primary band and introduces interference to it only. Accordingly, *PI-algorithm* is proposed to solve the power allocation problem efficiently. As a result, the two steps separation reduces the original problem complexity to be solvable with  $\mathcal{O}(N^3)$  complexity where  $N$  is the number of subcarriers. Moreover, the *PI-algorithm* in addition to the assumption of the nearest primary band assignment further reduce the complexity from  $\mathcal{O}(N^3)$  to  $\mathcal{O}(N \log N) + \mathcal{O}(L)$  where  $L$  is the number of primary bands. By simulating the different algorithms, the following results are outlined:

- The proposed *PI-algorithm* approaches the optimal solution and outperforms the previously proposed algorithms in the literature.
- The assumption that every subcarrier is belonging to the nearest primary band is reasonable as the maximum interference constraints are slightly violated. This implies that when such an assumption is applied, the considered interference constraints should be marginally lower than the pre-specified one by the primary system.
- While respecting the interference constraints, it is verified that transmitting over both active and non-active primary bands simultaneously achieves higher capacity than transmitting over active bands only, i.e. overlay spectrum access. The difference is highly dependent on the channel status between primary and secondary users. Channels with high attenuation result less interference to the primary system and allow the secondary users (SUs) to use more powers which improves the overall CR capacity.
- Due to its small sidelobes and due to the loss caused by the cyclic prefix (CP) insertion in the OFDM symbols, FBMC achieves higher performance than OFDM. It is worth

mentioning that using FBMC with the assumption of that the subcarrier is introducing interference to the nearest primary band only will not probably violate the interference constraints due to the almost negligible interference introduced by the FBMC.

## Chapter 4

This chapter considers the resource management problem in uplink scenario. Therefore, the global power constraint in the downlink case is replaced by multiple per-user power constraints. Additionally, the interference to the primary bands is not only induced by one source, i.e. CBS, as in the case of downlink but it is induced from different SUs. The channel conditions between each SU and the primary bands are different. The consideration of fairness constraint between the SUs complicates more the problem. As the problem is a mixed-integer optimization problem, efficient low complexity algorithm is proposed. The algorithm performs the allocation in two sperate steps. The subcarrier to users allocation is performed first and followed by the power allocation on the subcarriers. Unlike the downlink case, allocating the subcarrier to the user with the best channel condition is not optimal in uplink. Accordingly, we developed an algorithm that performing the subcarrier allocation taking into account the different constraints. The fairness is considered in the first step by reducing the outage probability of having users whose instantaneous rate is below the minimum required rate. After that, the per-user power is distributed among the subcarriers by modifying the *PI-algorithm* to fit into the uplink configuration. The following results are outlined:

- The capacity achieved by the proposed algorithm is near the optimal one evaluated by the exhaustive search algorithm. Additionally, the proposed algorithm outperforms the algorithms presented in literature. The proposed algorithm reduces the computational complexity from  $\mathcal{O}(N^3M^N)$  required in the exhaustive search to  $\mathcal{O}(N \log N) + \mathcal{O}(NM)$  where  $N$  is the number of subcarriers and  $M$  is the number of SUs.
- By comparing the achieved capacities of the proposed algorithm with and without applying the fairness constraints and also comparing the outage probability curves of them, one can notice that although the capacity loss from introducing the fairness constraint is small, the proposed algorithm with fairness can maintain the fairness between the users which reveals the excellent overall performance of the proposed algorithm.
- Simulations show that the resource allocation used in the conventional (non-cognitive)



multicarrier systems is inefficient in the cognitive ones except in the cases when the CR system is acting similar to the non-cognitive system. This happens when the interference constraint is high or when the power constraints are low. This is because the available power is not able to induce interference to the primary bands more than the maximum allowable limit. Additionally, since the number of subcarriers allocated to every SU is inversely related with the number of SUs, the CR system with few SUs might be close to the non-cognitive one because less power is allocated to each subcarrier and consequently small amount of interference is introduced to the primary bands.

## Chapter 5

Unlike the previous chapters, this chapter deals with the relayed transmission scenario. The resource management problem in a dual-hop multi-relay decode-and-forward (DF) multicarrier based CR system is tackled. The transmission from the source to destination is performed in two time slots. The interference introduced to the primary system at every time slot should not exceed the maximum interference temperature limit that can be tolerated by the primary system. The source can transmit directly to the destination or via relays. If the relayed transmission is selected, the subcarrier in the source should be paired with another one in the destination side. This subcarrier pair has to be assigned to one relay exclusively. Therefore, to decide the transmission way, i.e. direct or relayed, and to find the subcarrier pairs, relay assignment and power levels, the problem is formulated as an optimization problem. Although that the formulated problem is not convex, the problem satisfies the time sharing condition and hence, the dual decomposition technique is applied to obtain asymptotically optimal solution with zero duality gap in the limit of having sufficiently large number of subcarriers. By the dual decomposition technique, the power is evaluated for every possible subcarrier pair and relay assignment and for the direct transmission as well. Afterwards, the best relay is determined when the subcarrier is used for the relayed transmission. Eventually, the Hungarian method is adopted to determine the best transmission way for every subcarrier and to find the final subcarrier pairs. The subgradient method is applied to update the dual variables in every iteration. As the subgradient algorithm requires high numbers of iterations to converge to the optimal solution, a heuristic suboptimal algorithm is proposed to reduce the complexity. The following results are outlined

- By applying the dual decomposition technique, the original mixed-integer problem can

be solved in polynomial time. The suboptimal algorithm further reduces the computational complexity of the dual decomposition scheme and has a near optimal performance and outperform the algorithm used in the non-cognitive systems. The suboptimal algorithm reduces the complexity from  $O(T(MN^2 + M(N!) + 2N + N^3))$  required by the dual decomposition technique to  $\mathcal{O}(MN + MN^2)$  where  $T$  denotes the number of iterations required to converge,  $M$  denotes the number of relays, and  $N$  is the number of subcarriers.

- The capacity of the system which is able to transmit over the direct link is more than that when the direct link is blocked for all the subcarriers in the source side. This is expected since the source has more flexibility to choose the best transmission way.
- A special case of having single-relay is studied. The algorithm used in non-cognitive systems is adapted to solve the cognitive one. This can be done by assuming that the power budgets is distributed uniformly on the subcarriers and the subcarriers are able to induce the same amount of interference. The minimum between these two quantities is selected and the subcarriers are paired according to the order of multiplication of the powers and channel gains in the source and the relay. This algorithm has excellent performance compared with the optimal and outperform the case when there is no subcarrier pairing, i.e. the relay have to forward the information on the same subcarriers used by the source.

## 6.2 Future Work

Different CR scenarios has been considered in this dissertation. However, there are still many open issues to analyze. In the following, some important future research directions are listed

- The work presented in chapter 3 and chapter 4 considers that the primary and secondary systems are located in the same cell and there is only one CBS. Considering the multi-cell scenario is a possible future work extension where the subcarrier, powers and users should be distributed properly between the different BSs. Me et al. in [1] studied the co-existence between the primary and cognitive networks in multicell orthogonal frequency division multiple access (OFDMA) systems. Each CBS is assumed to be collocated with

one primary BS and transmitting in different frequencies (overlay access). Additionally, CR system can use overlapping channels with the neighboring cells. One of the limitation of this work is that it assumes that the CR can transmit only when the primary network is operating in the uplink mode. This assumption is used by the authors to limit the interference constraint to be related only to the primary BS and not to the users. Although this assumption simplifies the problem, it introduces more limitations on the time of the spectrum usage. More work should be performed to consider the case where all/part of the primary BSs are operating in the downlink mode where more careful resource allocation is required to avoid the interference. This relaxation requires more deep study on the way of reducing the coordination communications between the nodes. Additionally, the inter-cell overlay access should consider the out of band interference to adjacent bands which is not considered by the authors. More recent work has been presented by Choi et al. in [2] to consider the downlink subchannel and power allocation in multi-cell OFDMA CR networks. The proposed scheme consists of three different blocks: 1) fairness block which allocates more resources to the cell with high data rate requirements, 2) power allocation block to allocate the powers to different users in such a way that limited interference is induced to the primary users (PUs), and 3) subchannel allocation block to distribute the available frequency bands between cells. The authors assume an exclusive channel allocation, i.e. the channel allocated to one cell is not used by any of the nearby cells. The PUs use point-to-point communication and the interference constraints to them are converted into several maximum transmit power constraints for every CBS and subchannel. Extension of this work to consider the uplink scenario is not trivial. In uplink, the interference induced by every user should be considered in the scheduling process which is different from the downlink case where the selection of users does not affect the interference constraints. Additionally, adaptive frequency reuse factor might be applied. Specifically, the spectrum can be shared between the cells when there is no users in the cell edges while exclusive allocation is preferred when severe inter-cell interference is expected. The door is still open for developing low complexity and efficient algorithms in both downlink and uplink scenarios.

- In this dissertation, it is considered that the resource management is performed in a centralized way. Distributed resource allocation algorithms is of great interest. Depending

on the problem formulation, the distributed algorithms might be derived from the centralized one as given by [3–5]. In [3, 4], the dual decomposition framework is adopted to find the centralized solution which gives rise to the realization of the distributed solutions. Limited coordination is assumed between the participating network elements and the opportunistic scheduling can be performed by using the concept of virtual clock by which every user estimates its channel information during the sensing slot which is equal for all the users. Afterwards, a virtual timer starts at the beginning of the scheduling slot. The timer of the best user on a certain subchannel has the the smallest timer value and expires first. The user reserves the channel by sending a flag packet to all the users. Alternatively, game theoretic approaches can be used in the design of the algorithms [6–8].

- The assumption of perfect knowledge of CSI as well as the channel occupancy information is not realistic. There always exists some uncertainty in this information due to unreliable feedback channel or due to the sensing errors. The impact of the lack of the perfect information should be analyzed and appropriate algorithms are required accordingly. The imperfect CSI and sensing information is considered by Ruan et al. in [9] to find the optimal power allocation in OFDM based CR systems. The extensions of these results to consider the OFDMA case is a good step forward. In [10] and [11], the OFDMA based CR system is considered. In [10], the imperfect CSI is considered by applying a simple back-off scheme. The estimated channel gains are multiplied by a factor to consider the estimation errors while the interference constraint is multiplied by another factor to avoid that the actual interference exceeds the threshold value. In [11], Almalfouh et al. consider imperfect channel sensing information by modifying the value of the interference introduced in the perfect case. The modification is performed by adding a term represents the average interference that will introduced to the primary system due to the false alarm probability. The imperfection issue and the way of exchanging the channel information between the primary system and the CR nodes are still an open problems and need more investigation.
- In chapter 5, we considered the dual-hop DF scenario. The multiple-hop network is a natural extension. Additionally, more relaying protocols may be studied like the two-way relaying and the adaptive relaying. In the two-way relaying [12–14], bidirectional transmission is established between the end nodes where the relay receives from the end

nodes simultaneously in the first time slot, and broadcast these messages in the second time slot. This doubles the spectrum efficiency of the one-way relaying. In the adaptive relaying [15–17], the relay decides the forwarding technique based on the instantaneous channel quality and the decoding ability. To the best of our knowledge, there is no significant work in the resource allocation in multicarrier based CR system with two-way relaying or adaptive relaying. Eventually, the adaptation of the time slot duration in CR environment is a possible future work extension.

- The amount of research devoted to OFDM system is not comparable to that devoted to FBMC system which receives less attention. Although several studies highlights the powerfulness of the FBMC physical layer in CR environment, a lot of effort has to be performed in order to implement a real FBMC based system. We will keep working on developing the FBMC techniques and highlighting its advantages in the systems.

## Bibliography

- [1] Y. Ma, D.I. Kim, and Z. Wu, "Optimization of OFDMA-based cellular cognitive radio networks," *IEEE Transactions on Communications*, vol. 58, no. 8, pp. 2265–2276, 2010.
- [2] K. Choi, E. Hossain, and D. Kim, "Downlink subchannel and power allocation in multi-cell OFDMA cognitive radio networks," *IEEE Transactions on Wireless Communications*, no. 99, pp. 1–13, 2011.
- [3] P. Cheng, Z. Zhang, H.H. Chen, and P. Qiu, "Optimal distributed joint frequency, rate and power allocation in cognitive OFDMA systems," *IET Communications*, vol. 2, no. 6, pp. 815–826, 2008.
- [4] Duy Trong Ngo and Tho Le-Ngoc, "Distributed resource allocation for cognitive radio networks with spectrum-sharing constraints," *IEEE Transactions on Vehicular Technology*, vol. 60, no. 7, pp. 3436–3449, Sept. 2011.
- [5] Y. Zhang and C. Leung, "A distributed algorithm for resource allocation in OFDM cognitive radio systems," *IEEE Transactions on Vehicular Technology*, vol. 60, no. 2, pp. 546–554, 2011.
- [6] Y.Y. Lin and K.C. Chen, "Distributed spectrum sharing in cognitive radio networks-game theoretical view," in *7th IEEE Consumer Communications and Networking Conference (CCNC'10)*, 2010, pp. 1–5.
- [7] C.H. Ko and H.Y. Wei, "Game theoretical resource allocation for inter-bs coexistence in IEEE 802.22," *IEEE Transactions on Vehicular Technology*, vol. 59, no. 4, pp. 1729–1744, 2010.
- [8] J. Wang, G. Scutari, and D.P. Palomar, "Robust MIMO cognitive radio via game theory," *IEEE Transactions on Signal Processing*, vol. 59, no. 3, pp. 1183–1201, 2011.
- [9] L. Ruan and V.K.N. Lau, "Power control and performance analysis of cognitive radio systems under dynamic spectrum activity and imperfect knowledge of system state," *IEEE Transactions on Wireless Communications*, vol. 8, no. 9, pp. 4616–4622, 2009.

- [10] T. Qin, C. Leung, C. Miao, and Z. Shen, “Resource allocation in a cognitive radio system with imperfect channel state estimation,” *Journal of Electrical and Computer Engineering*, vol. 2010, pp. 29, 2010.
- [11] S.M. Almalfouh and G.L. Stuber, “Interference-aware radio resource allocation in OFDMA-Based cognitive radio networks,” *IEEE Transactions on Vehicular Technology*, vol. 60, no. 4, pp. 1699–1713, May 2011.
- [12] B. Rankov and A. Wittneben, “Spectral efficient protocols for half-duplex fading relay channels,” *IEEE Journal on Selected Areas in Communications*, vol. 25, no. 2, pp. 379–389, 2007.
- [13] C.K. Ho, R. Zhang, and Y.C. Liang, “Two-way relaying over OFDM: optimized tone permutation and power allocation,” in *IEEE International Conference on Communications (ICC’08)*, 2008, pp. 3908–3912.
- [14] K. Jitvanichphaibool, R. Zhang, and Y.C. Liang, “Optimal resource allocation for two-way relay-assisted OFDMA,” *IEEE Transactions on Vehicular Technology*, vol. 58, no. 7, pp. 3311–3321, 2009.
- [15] B. Can, H. Yomo, and E. De Carvalho, “Hybrid forwarding scheme for cooperative relaying in OFDM based networks,” in *IEEE International Conference on Communications (ICC’06)*, 2006, vol. 10, pp. 4520–4525.
- [16] Y. Li, B. Vucetic, Z. Chen, and J. Yuan, “An improved relay selection scheme with hybrid relaying protocols,” in *IEEE Global Telecommunications Conference (GLOBECOM’07)*, 2007, pp. 3704–3708.
- [17] A. Khan and V. Kuhn, “Power optimization in adaptive relay networks,” in *IEEE Global Telecommunications Conference (GLOBECOM’10)*, Dec. 2010, pp. 1–5.

